

7UM62x - Installation Instructions for 100% SEF (20Hz) and Rotor EF (1-3Hz & R,f_n)

100% Stator Earth Fault (20 Hz principle)

Example 1: 20Hz Equipment installed close to neutral transformer

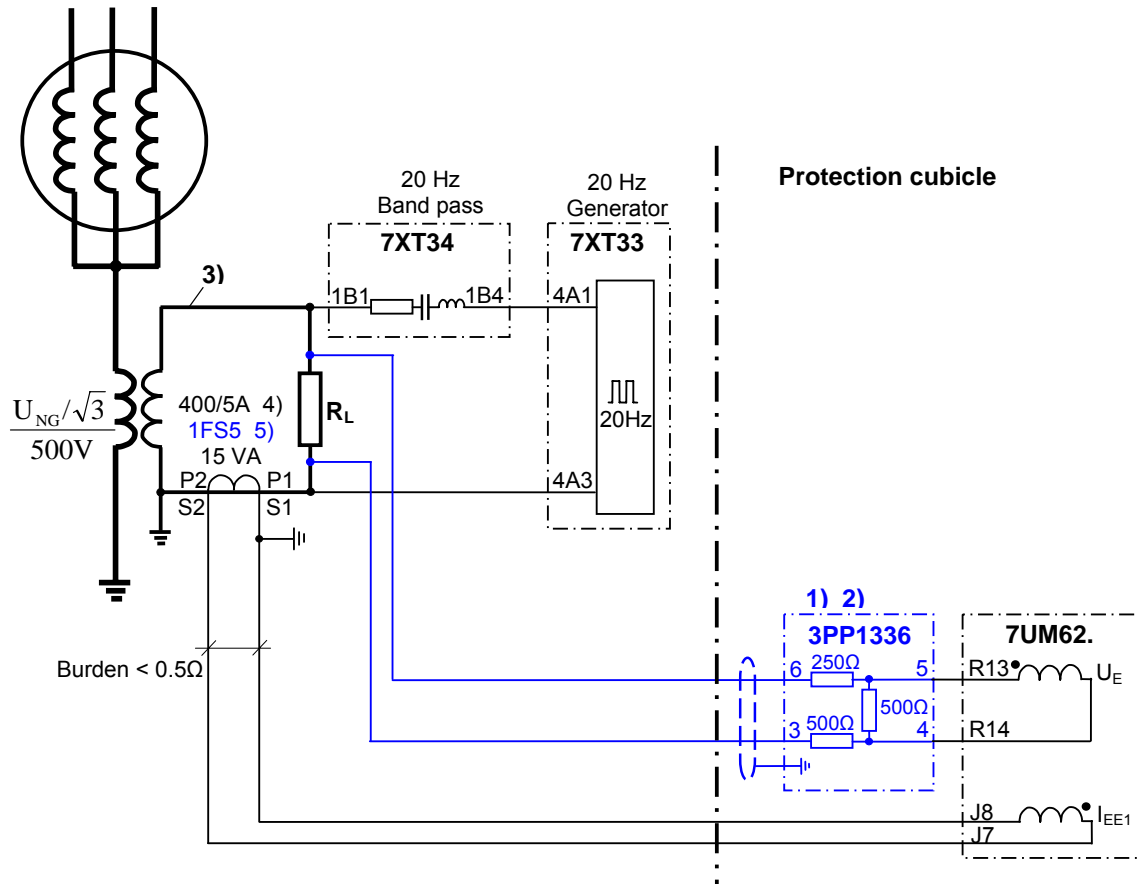

- 1) The (separate) Voltage divider is only necessary in case of secondary voltages higher than 200V a.c.
- 2) Voltage divider to be installed close to 7UM62 device to minimize interference in these leads.
- 3) Cross section according to the maximum (short time-) current.
- 4) The transformation ratio of the miniature CT 400A/5 A can be halved to 200A/5A by passing the primary conductor twice through the transformer window.
- 5) Principally also a class P core could be used.

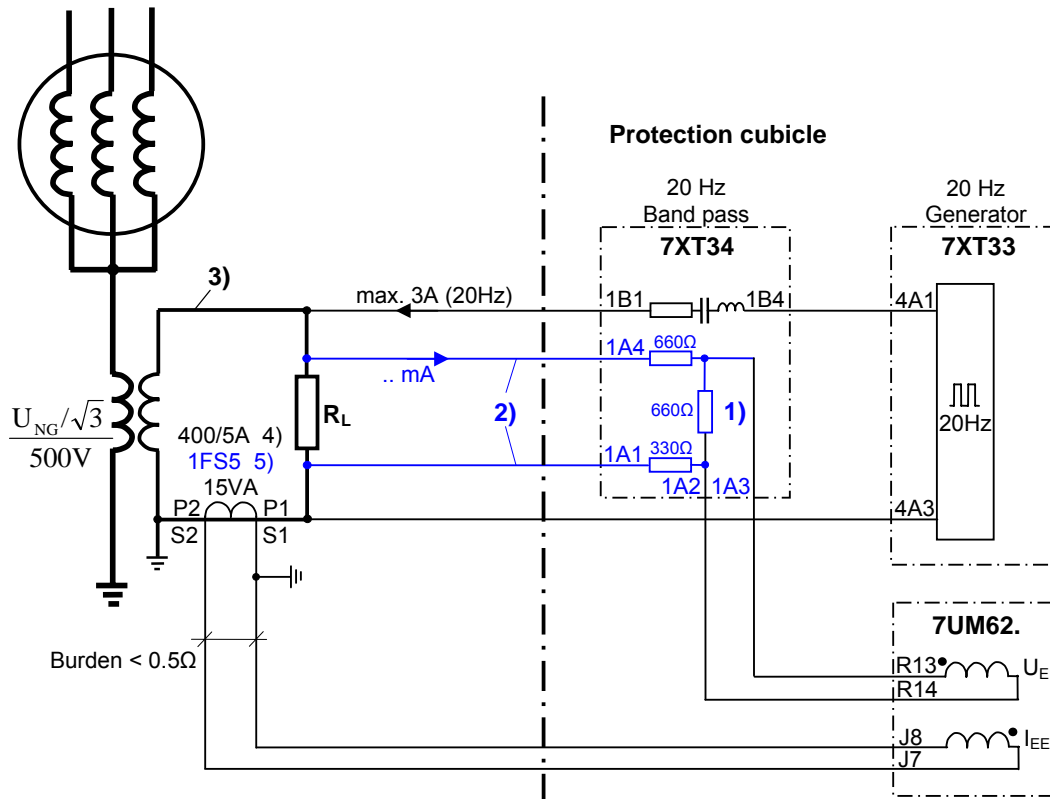
Example 2: 20Hz Equipment installed inside protection cubicle

- 1) Voltage divider is only necessary in case of secondary voltages higher than 200V a.c.
- 2) The voltage divider must be connected via two separate leads directly to the load resistor R_L . If not, the measured (20Hz) voltage is too high. (and the calculated resistance as well)
Example: R_L shall be 1 Ω and the loop resistance between band pass/20 Hz generator and load resistor shall be 1 Ω as well \rightarrow measured 20Hz voltage and calculated resistance are approximately twice than real.
- 3) Cross section according to the maximum (short time-) current.
- 4) The transformation ratio of the miniature CT 400A/5 A can be halved to 200A/5A by passing the primary conductor twice through the transformer window.
- 5) Principally also a class P core could be used.

Rotor Earth Fault (1-3 Hz principle)

Example 1: coupling unit 7XR6004 installed inside excitation cubicle

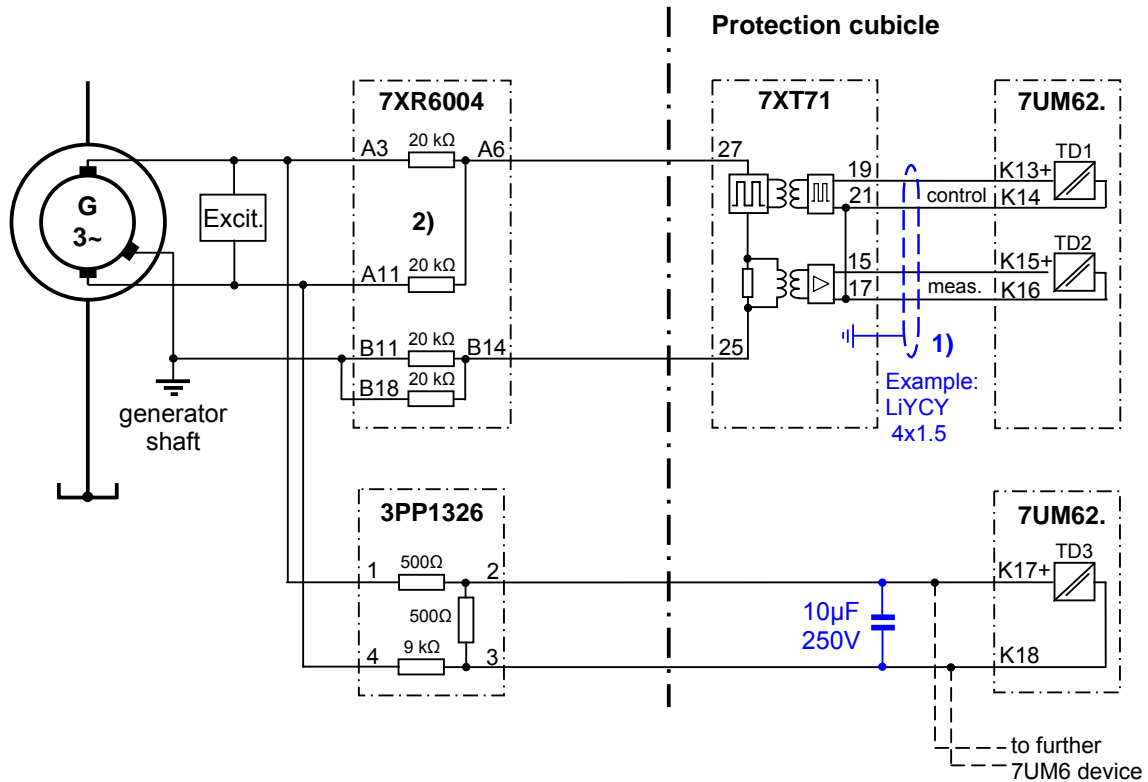

- 1) The distance between controller unit 7XT71 and protection device 7UM62x should be as short as possible (to be installed in the same cubicle). The connections in between shall be laid closely together and twisted or a screened cable should be used.
- 2) connection example for excitation voltages < 850V d.c.
(an other connection example for excitation voltages < 1200V d.c. can be found in the Quick reference 7XR6004) :
http://siemens.siprotec.de/download_neu/html_nav/ind_acc_e.htm

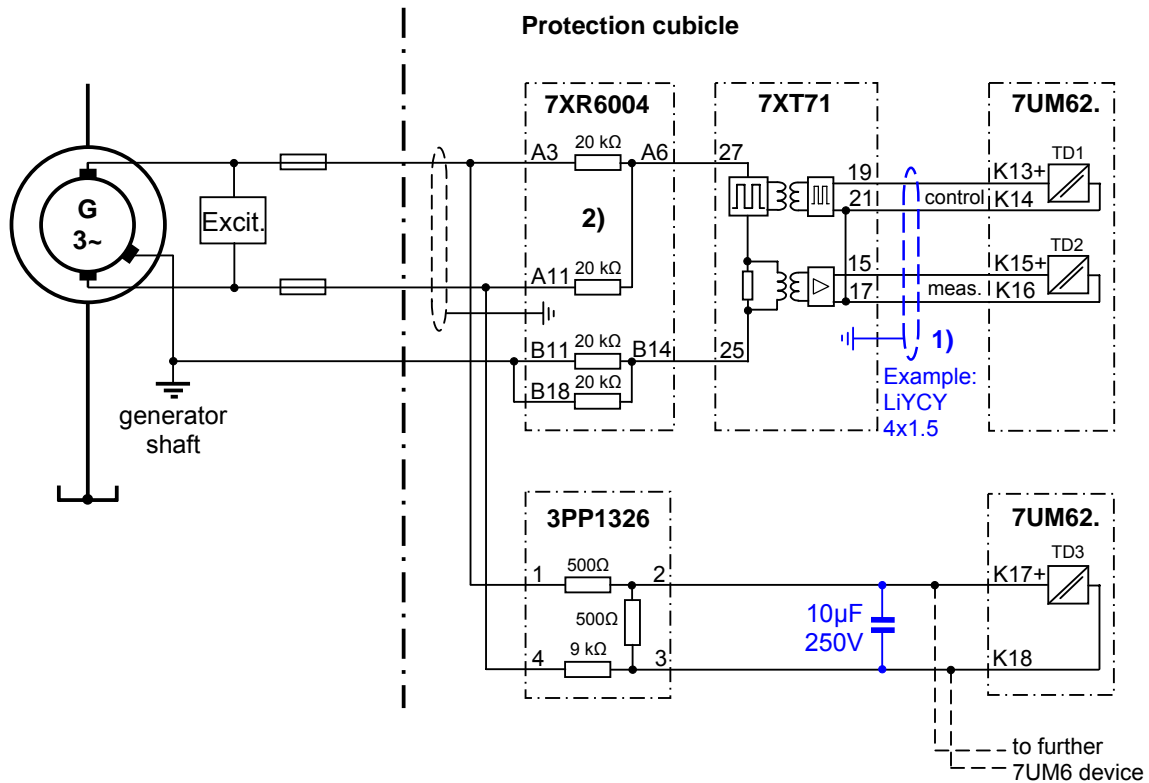
Example 2: coupling unit 7XR6004 installed inside protection cubicle

- 1) The distance between controller unit 7XT71 and protection device 7UM62x should be as short as possible (to be installed in the same cubicle). The connections in between shall be laid closely together and twisted or a screened cable should be used.
- 2) connection example for excitation voltages < 850V d.c.
(an other connection example for excitation voltages < 1200V d.c. can be found in the Quick reference 7XR6004):
http://siemens.siprotec.de/download_neu/html_nav/ind_acc_e.htm

Rotor Earth Fault (R, f_n principle)

Example 1: R.M.S value of $I_R > 0.2 \text{ A a.c.}$ (Thumb rule $U_{\text{ExcLoad}} > 150\text{V}$)

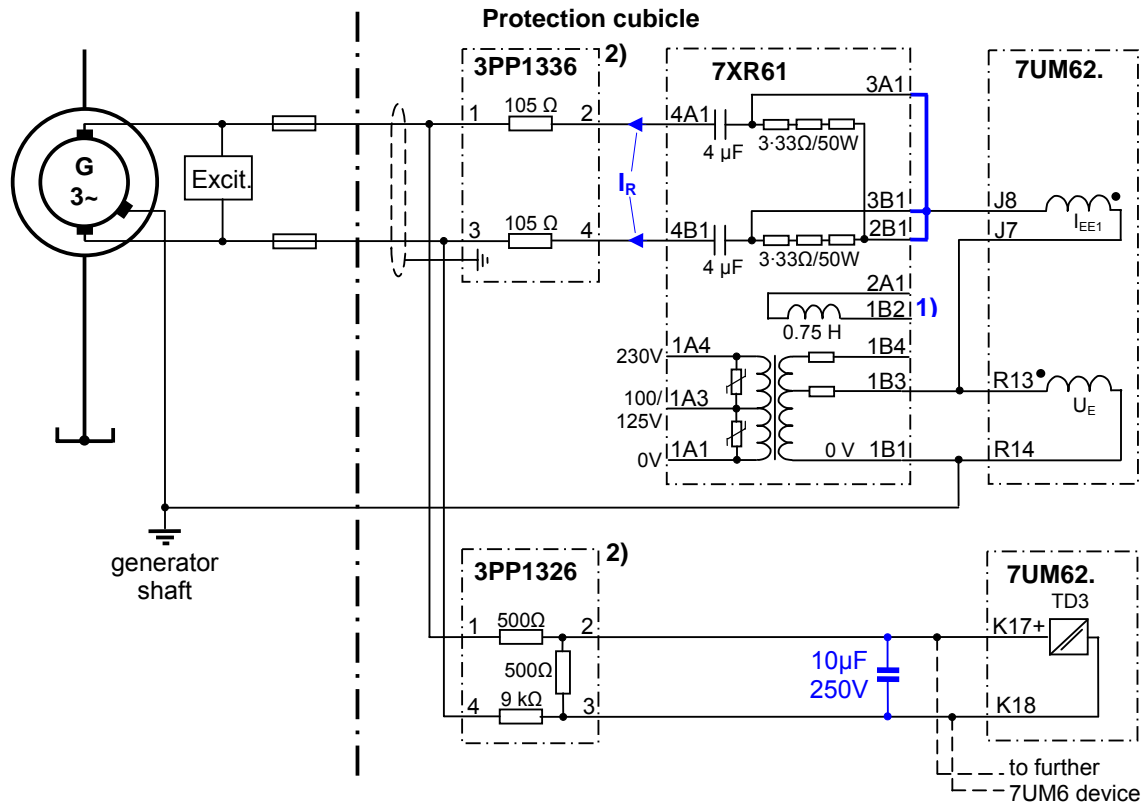

The internal resistors can not be used in case of higher currents (I_R). In the event of large harmonics content in the rotor voltage an external series resistor, type 3PP1336-0DZ-K2Y is recommended for the protection of the coupling capacitors.

In this case the internal resistors should be shorted like in the Figure above.

Refer also to "Directions for use 7XR61" (Connection Examples):

http://siemens.siprotec.de/download_neu/html_nav/ind_acc_e.htm

- 1) In the absolutely most cases there is no need to connect the 0.75 H Inductor.
The decision has to be made during hot commissioning.
- 2) Can be also located inside excitation cubicle

Example 2: R.M.S value of $I_R < 0.2 \text{ A a.c.}$ (Thumb rule: $U_{ExcLoad} < 150\text{V}$)

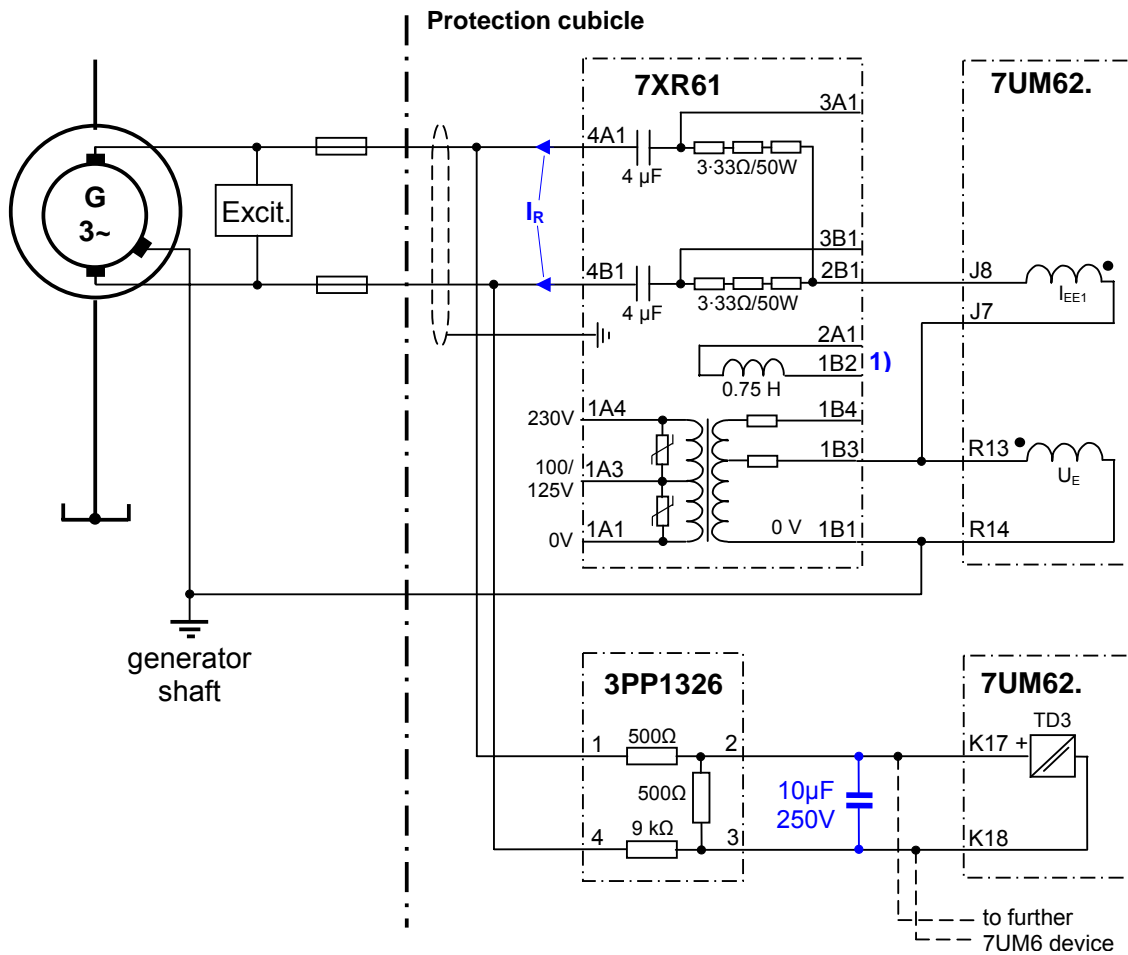

Refer also to “Directions for use 7XR61” (Connection Examples):
http://siemens.siprotec.de/download_neu/html_nav/ind_acc_e.htm

- 1) In the absolutely most cases there is no need to connect the 0.75 H Inductor. The decision has to be made during hot commissioning.