



SIEMENS



PROCESS INSTRUMENTATION

Clamp-on ultrasonic **flow measurement for gas**

Process instrumentation and control systems

www.usa.siemens.com/clamp

Clamp-on technology for flow measurement

Non-intrusive flow measurement with the clamp-on technique uses ultrasonic waves to measure flow. Clamp-on flow meters measure the difference in time between the transmission of an ultrasonic signal from one sensor to its reception by a second sensor. Known as transit-time, this measurement is made both upstream and downstream of flow, and the comparison makes it possible to calculate flow velocity. This is because the signal travels faster in the same direction of flow than it does when traveling against flow. With non-intrusive flow meters, operators profit from a flexible and cost-effective solution for measuring gases independent of pressure, temperature or viscosity and with guaranteed accuracy.

For more than 50 years, Siemens has been advancing clamp-on technology to leverage the relationship between the sensors, pipe and medium for optimal measurement results. Our WideBeam (or Lamb-wave) sensors have a designated range of frequencies suitable for the most common pipe wall thicknesses. The wide footprint of WideBeam sensors results in a broad point of contact as the signal travels through the flow stream, which provides our transmitters with a greater amount of flow profile information than earlier-style sensors.

For the majority of applications, WideBeam sensors ensure better performance over a wider array of medium conditions. Independent of the technology and sensor variant used, clamp-on measurement supports pipe sizes from 2 inches to over 60 inches.

Gas measurements with the SITRANS FS230 flow system

A gas measurement with the SITRANS FS230 flow system consists of the following components:

- One pair of SITRANS FSS200 clamp-on sensors
- SITRANS FS-DSL Digital Sensor Link
- SITRANS FST030 transmitter

Sensor spotlight: SITRANS FSS200

SITRANS FSS200 WideBeam high-precision sensors are optimized for gas applications, offering maximum transmission power and high signal clarity. To assure optimal performance, WideBeam technology tests the entire frequency range of the sensors upon startup to determine the ideal measuring frequency. This ensures the sensors can be used in varying measurement conditions.

Electronics spotlight: Internal/external Digital Sensor Link

The Digital Sensor Link (DSL) is the link between the sensors and the transmitter. This electronics module receives and digitizes the analog signals from the sensors before sending them to the transmitter.

A SITRANS FS230 flow system comes with two options: an integrated DSL or an external DSL in an explosion-proof housing. The use of the external DSL enables measurements when the transmitter needs to be located a great distance from the sensors. In these cases, the DSL module is mounted close to the sensors. The short analog cables allows optimal EMC protection before the analog signals are sent to the transmitter in digitized form.

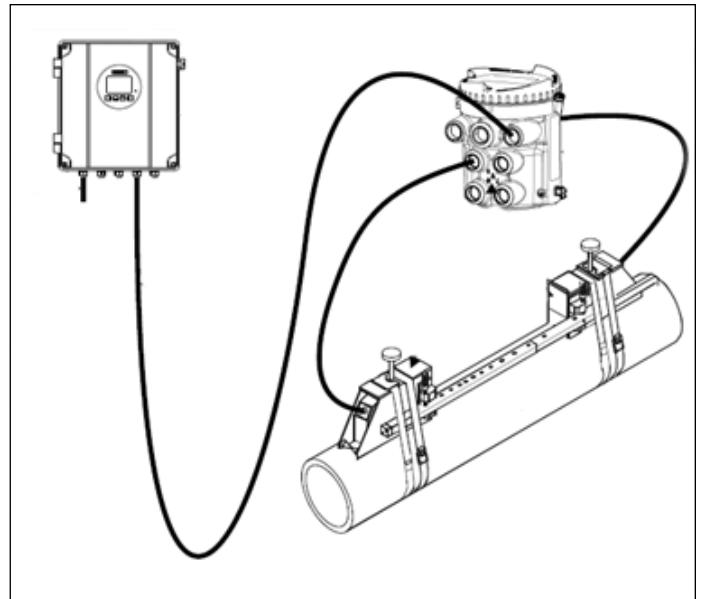

Transmitter spotlight: SITRANS FST030

The SITRANS FST030 transmitter was designed and developed for the highest accuracy. In laboratory conditions the SITRANS FST030 achieves measurement errors of less than 1% (for flow velocities starting from 1.5 f/s). In practice, however, lab conditions are seldom replicated in the field. Less-than-optimal inlet and outlet sections often complicate accurate measurement. Clamp-on technology offers the option of mounting additional sensors to improve the measuring performance. To ensure the highest possible accuracy, the SITRANS FST030 transmitter supports up to four paths.

The updated SITRANS FS230 comes with a frequency pass filter. Upon installing the sensors, the transmitter confirms the frequency at which the best measurement signals are obtained. This particular frequency is then retained and kept in a defined range by the help of a bandpass filter to suppress interferences.

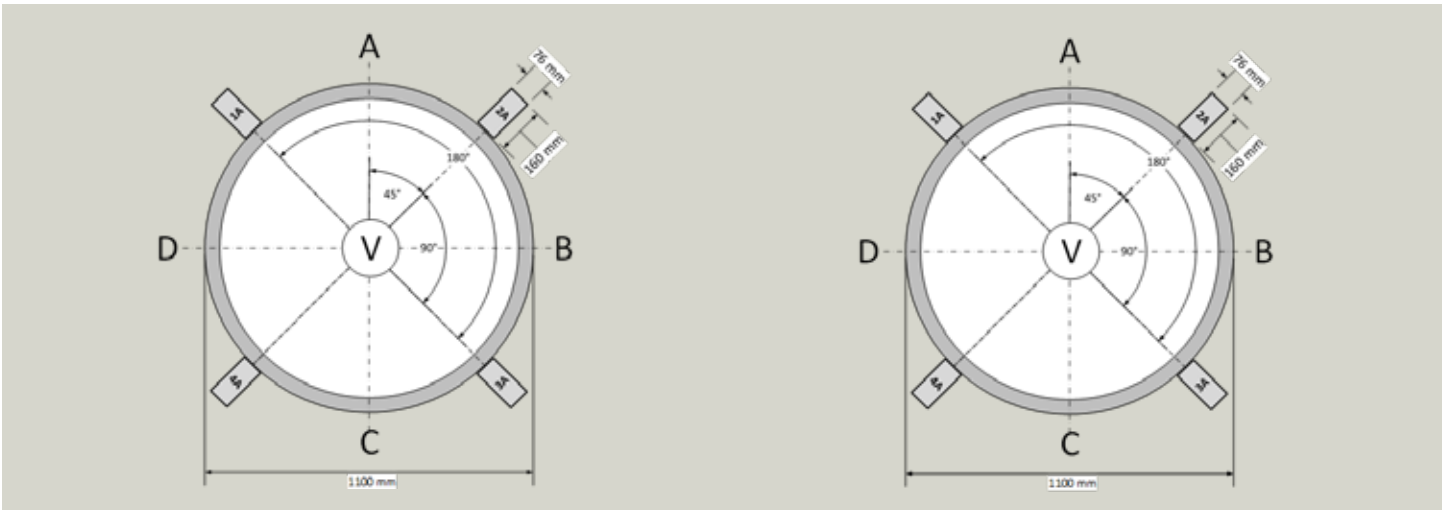

Sensor mounting options for 4-path measurements: reflect mode (left), direct X mode (right).

Benefits of the SITRANS FS230 for gas flow measurement include:

- Suitable for new and existing systems
- Robust sensor assembly and device construction for years of operation
- Measurement without media contact
- Real 100 Hz signal update rate for optimal accuracy in dynamic flow conditions
- Highly repeatable accuracy
- Easily expandable up to 4-path measurement
- Reynolds compensation including gas quality, pressure and temperature (with internal AGA 8 gas table)
- State-of-the-art diagnostics

Technical details	
Nominal sizes	2" ... 60"
Pipe wall thickness	0.08" ... 1.38" (on request)
Min. pressure (steel pipes)	116 PSI
Temperature	-40 °F ... 176° F, up to 248 °F possible (on request)
Flow speed	Up to 131 f/s

For gas measurements, especially in large pipes, it is advisable to mount the sensors in direct mode rather than in reflect mode. Multipath measurements are strongly recommended.

Based on the actual measured values of the current flow rate, the flow meter can correct for flow condition variations by accessing an internal AGA 8 table, which takes pressure and temperature into account. The transmitter determines the current viscosity, calculates the Reynolds number and adjusts the volume flow accordingly. The measuring device is thus able to output the current volume or carry out a mass or standard volume calculation.

Typical gas applications for the SITRANS FS230

- Check metering (temporary checks of built-in measurements)
- Operating measurements in high-pressure gas networks
- Gas storage: storage and retrieval, balancing
- Chemical industry: production, process monitoring, internal accounting
- Gas power plants: compressors (generally for monitoring and control)
- Temporary billing measurements for conversion projects (infield calibration possible)

Measuring everything that matters:

[*usa.siemens.com/pi*](http://usa.siemens.com/pi)

Siemens Process Instrumentation offers best-in-class measurement and seamless integration into your automation system. We are the total solution provider for flow, level, pressure, temperature, weighing, positioners and more.

Legal Manufacturer

Siemens Industry, Inc.
100 Technology Drive
Alpharetta, GA 30005
United States of America
Telephone: +1 (800) 365-8766
usa.siemens.com/pi
Order : No.PIBR-00041-0322

This document contains a general description of available technical options only, and its effectiveness will be subject to specific variables including field conditions and project parameters. Siemens does not make representations, warranties, or assurances as to the accuracy or completeness of the content contained herein. Siemens reserves the right to modify the technology and product specifications in its sole discretion without advance notice.