

Features and Ratings

- 1 PHASE, 3 WIRE, 120/240V ~
- 22K AIC MAIN BREAKER FACTORY INSTALLED (SEE WIRING DIAGRAM FOR DETAILS)
- GROUND BARS INSTALLED
- TYPE N1 INDOOR ENCLOSURE
- ANSI 61 GRAY POWDER COATED ENCLOSURE
- ENCLOSURE AND TRIM SOLD SEPARATELY

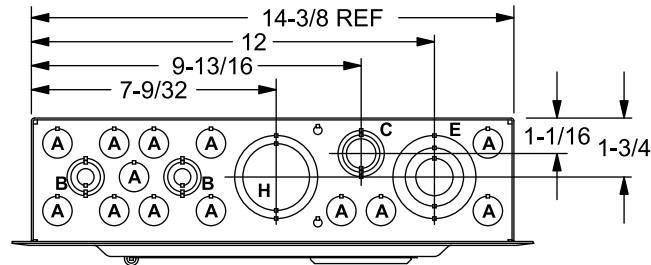

VIEW SHOWN WITH TRIM REMOVED*

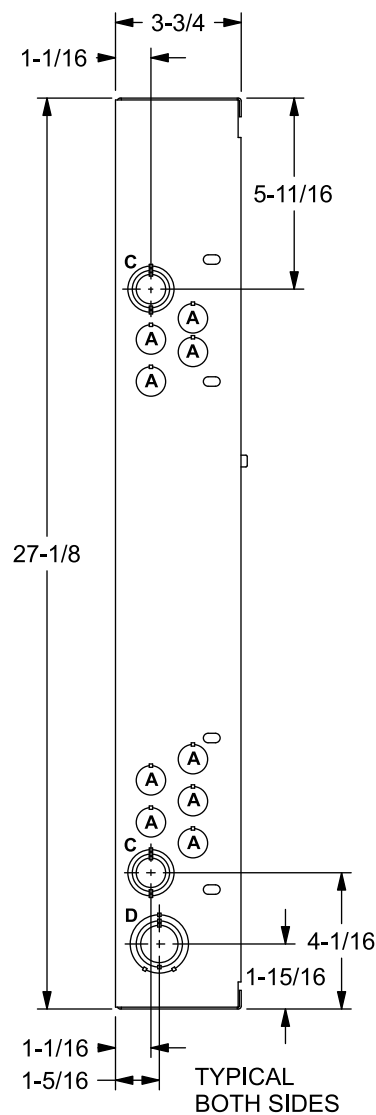

VIEW SHOWN WITH DOOR REMOVED*

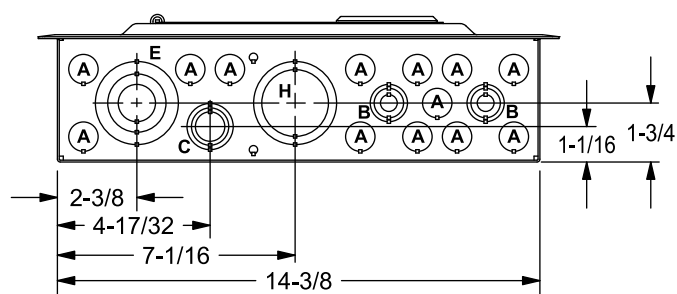
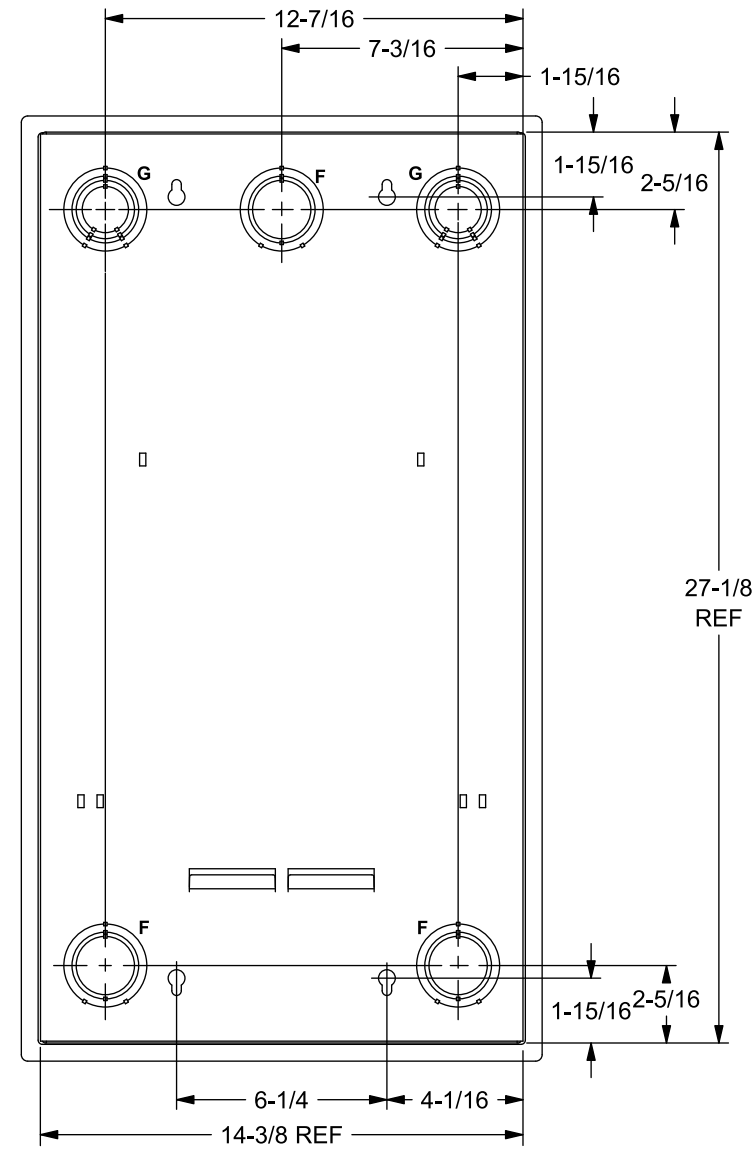
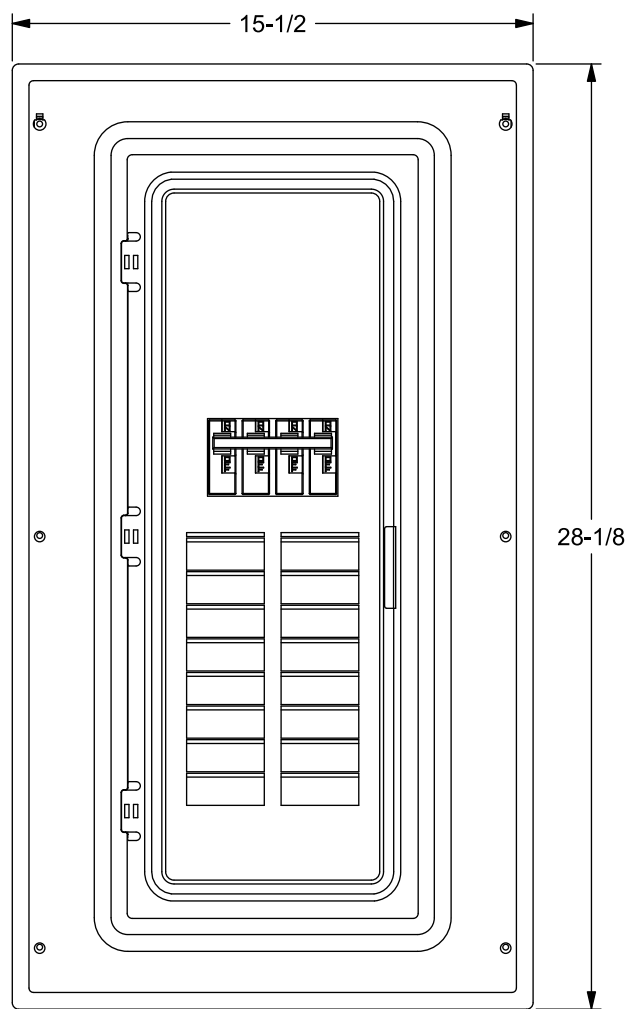

Catalog Numbers	Amps Max	Number Spaces	Number Circuits	Bus Bar Material
BMW1632MB1150F	150	16	32	Aluminum
BMW1632MB1200F	200	16	32	Aluminum

Trim/Door Detail

*Trim/Door Assemblies Sold Separately

Catalog Number	Trim Color
TMW1632MB1200F	White
TM1632MB1200F	Gray

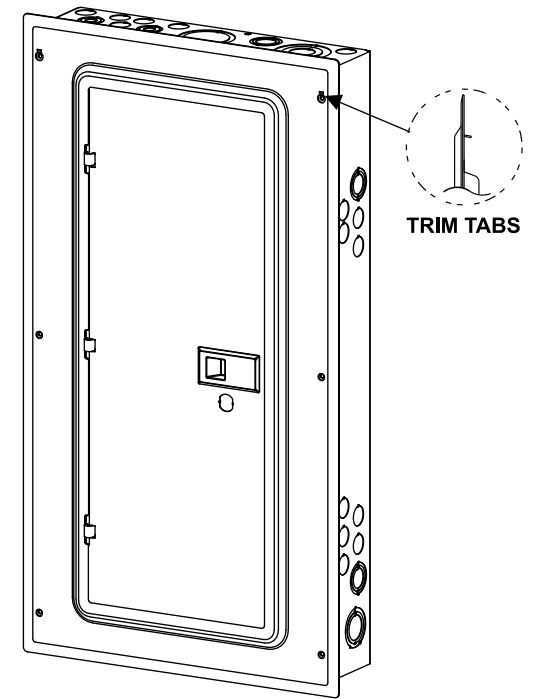

Terminal Wire Sizes and Torques

USE COPPER OR ALUMINUM 60°/75°C WIRE

Terminals	Wire Size AWG	Torque
A, B & N	250kcmil - 1 AWG	340 lb.-ins.
Neutral/Right Side	#10-14 CU/#10-12 AL	20 lb.-ins.
Ground Bar	#8	25 lb.-ins.
	#6	35 lb.-ins.
	#4	45 lb.-ins.
Grd. Conductors Only	(2) or (3) #10-14 CU or #10-12 AL	20 lb.-ins.
Left Side	1/0-#3	50 lb.-ins.
Ground Bar	#4-#6	45 lb.-ins.
Large Hole	#8	40 lb.-ins.
	#10-14 CU/#10-12 AL	35 lb.-ins.
Small Hole	#6	35 lb.-ins.
	#8	25 lb.-ins.
	#10-14 CU/#10-12 AL	20 lb.-ins.
ECLK1-2	2/0-#2	45 lb.-ins.
ECLK2	2/0-#4	135 lb.-ins.
ECLK3	300 kcmil - 1 AWG	340 lb.-ins.
Branch Breakers	See Marking on Breaker	

Schematic

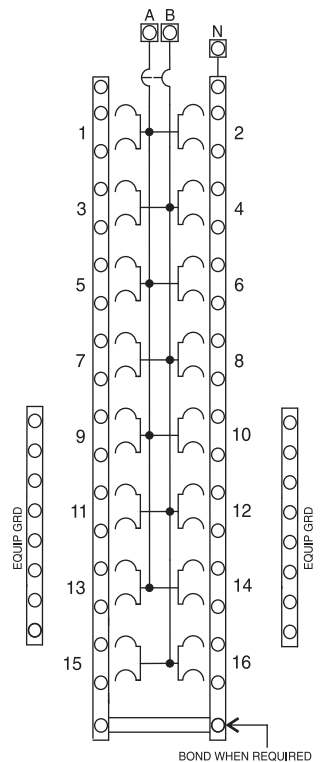

Accessories

Description	Cat. No.
Door Lock	ECQFL2
Trim Screw	ECTS2
Padlock Device for QP Breakers	ECQLD3
Padlock Device for QT Breakers	ECQLD4
Filler Plate	ECQF3

Knockouts (inches)	
A	1/2"
B	3/8", 1/2", 3/4"
C	1/2", 3/4", 1"
D	3/4", 1", 1-1/4"
E	3/4", 1-1/4", 1-1/2"
F	1-1/4", 1-1/2", 2"
G	1", 1-1/4", 1-1/2", 2"
H	1-1/2", 2"

© 2012 Copyright Siemens Industry, Inc.

SIEMENS
Siemens Industry, Inc.

Mobile Home Load Centers

Description: **1 Phase, Indoor, 16 Position, 150-200A Main Breaker Cut Sheet**

KAM 12/5/12 DO NOT SCALE DRAWING Dwg No: **BMW1632MB1200F**