



| Simogear

Siemens Drives Days 2021, Dolní Morava

| Kdo prezentuje

Ing. Vladimír Mýlek

Siemens s.r.o.
RC-CZ DI MC GMC
28.Října 150/2663
702 00 Ostrava

Telefon +420 724 057 093

E-mail vladimir.mylek@siemens.com

www.siemens.cz/pohony



SIMOGEAR

The new integrated explosion-protected geared motors

ATEX zone 2 and 22

SIMOGEAR The new integrated explosion-protected geared motors

Explosion-protected areas

Gases

(Zone 2 with gas/vapor)

- Painting systems
- Biogas stations
- Chemical and petrochemical industry
- Gas plants
- Wastewater



Dusts

(Zones 22 with dust/fibers)

- Power generation, e.g. Lump coal dust
- Agriculture, e.g. concentrated feed, malt, grain
- Processing plastics, e.g. rubber, natural rubber (caoutchouc)
- Wood industry, e.g. wood dust, wood resin

SIMOGEAR The new integrated explosion-protected geared motors

Suitable for zone 2 and 22

Safe area

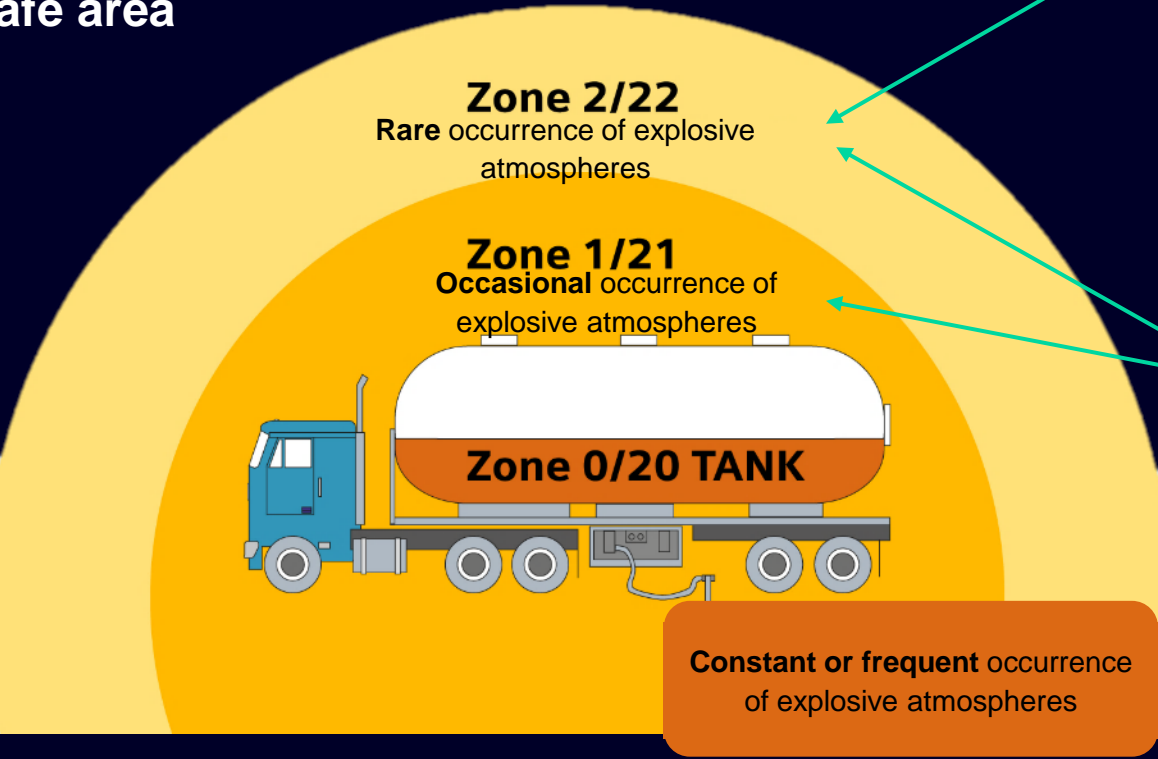

NEW integrated explosion-protected geared motor can be offered

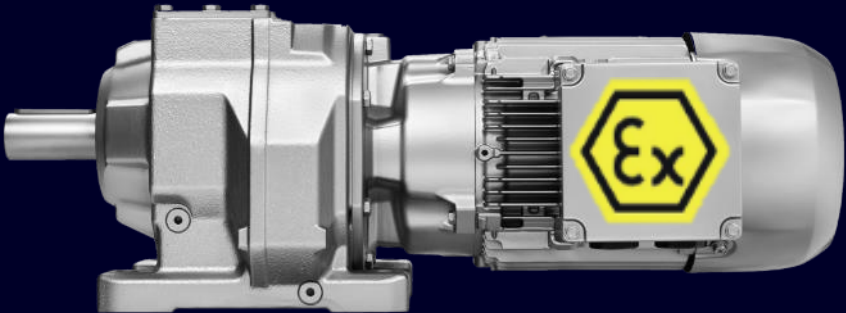

Explosion-protected gearboxes with adapter Mounting is additionally required.



SIMOGEAR The new integrated explosion-protected geared motors

Top highlights



Feature / Function	Benefits
<p>Easy selection in one tool</p>	<ul style="list-style-type: none"> Integration in DTK makes the selection and dimensioning extremely user friendly.
<p>Fully assembled from factory</p>	<ul style="list-style-type: none"> The integrated version with one MLFB can be easily ordered as one package.
<p>Compact design</p>	<ul style="list-style-type: none"> With the integration we can save installation space and be more effective.
<p>Competitive delivery times</p>	<ul style="list-style-type: none"> The customers can get solution delivered in 20 WD as a standard.
<p>Power range from 0,25kW up to 22kW</p>	<ul style="list-style-type: none"> The focus on applications and power range allows for short delivery times.
<p>Certified according to ATEX 2014/314/EU</p>	<ul style="list-style-type: none"> This certificate allows us to serve customers with focus in Europe.

* With encoder or brake delivery time 30WD

SIMOGEAR The new integrated explosion-protected geared motors

Product consist of

Motor			SIMOGEAR Gearbox			29	39	49	59	69	79	89	109	129	149	169	189		
Frame size	Power (at 50Hz)		1-stage	E															
	IE2	IE3																	
71	0,25 kW 0,37 kW		Helical Geared Motors	2 / 3 - stage	Z / D	D/Z29	D/Z39	D/Z49	D/Z59	D/Z69	D/Z79	D/Z89	D/Z109	D/Z129	D/Z149	D/Z169	D/Z189		
80	0,55 kW 0,75 kW					140 Nm	200 Nm	320 Nm	450 Nm	600 Nm	840 Nm	1680 Nm	3100 Nm	5000 Nm	8000 Nm	14000 Nm	19000 Nm		
90	1,1 kW 1,5 kW		Parallel Shaft Geared Motors	2 / 3 - stage	FZ / FD	F29	F39	F49				F69	F79	F89	F109	F129	F149	F169	F189
100	2,2 kW 3 kW					150 Nm	290 Nm	480 Nm	600 Nm	1000 Nm	1850 Nm	3100 Nm	4850 Nm	8000 Nm	14000 Nm	19000 Nm			
112	4 kW		Bevel Geared Motors	2-stage	B	B29	B39	B49											
132	5,5 kW 7,5 kW					110 Nm	250 Nm	450 Nm											
160	11 kW 15 kW			3 -stage	K			K39	K49	K69	K79	K89	K109	K129	K149	K169	K189		
180	18,5 kW 22 kW		220 Nm			420 Nm	600 Nm	820 Nm	1600 Nm	2900 Nm	4400 Nm	8000 Nm	13500 Nm	19500 Nm					
			Helical Worm Geared motors	2-stage	C	C29	C39	C49	C69			C89							
						110 Nm	235 Nm	400 Nm	680 Nm	1460 Nm									

We fulfil the EU-directive efficiency requirements valid from 07/2021 and 07/2023

SIMOGEAR The new integrated explosion-protected geared motors

Certified according to ATEX directive 2014/34/EU and CCC certification for Ex motor

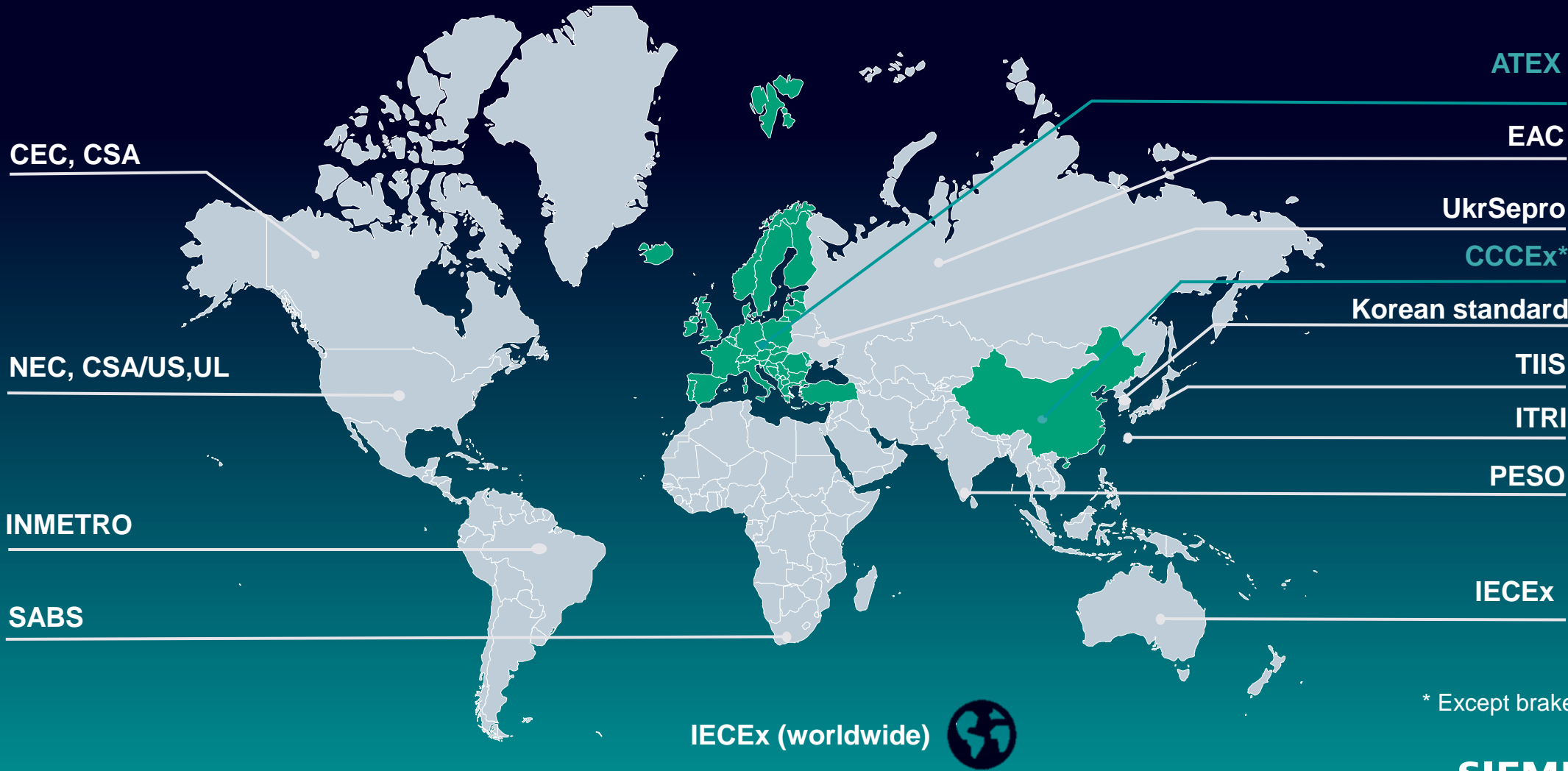

* Except brake

SIMOGEAR The new integrated explosion-protected geared motors

Suitable for zone 2 and 22

Example	Ex	II	3	G	Ex h	IIB	T3	
Meaning	Variant							ATEX classification
Classification	Explosion protection symbol	Ex						
Device group	Above-ground use		II					
Category	Zone 1, 21			2				
	Zone 2, 22			3				
Drive design	Explosive atmosphere caused by gas			G				
	Explosive atmosphere caused by dust			D				
Ignition protection type	Constructional safety/liquid immersion				Ex h			
Explosion group: Areas exposed to gases	High ignition power required					IIA		
	Medium ignition power required					IIB		
	Low ignition power required					IIC		
Exposed to dust	Lint					IIIA		
	Non-conductive dust					IIIB		
	Conductive dust					IIIC		
Temperature class for the zones Gas	<=450°C						T1	
	<=300°C						T2	
	<=200°C						T3	
	<=135°C						T4	
	<=100°C						T5	
Temperature limit for the zone Dust	<=85°C						T6	
							120°C	

Explosion sphere	Explosion group	Marking Type of protection gearbox	Marking Type of protection motor	Order code
Gas (G) Zone 2	IIB	Ex II 3G Ex h IIB T4 Gc	Ex II 3G Ex ec IIB T3 Gc	K72+K81
		Ex II 3D Ex h IIIB T120°C Dc		
	IIC	Ex II 3G Ex h IIC T4 Gc	Ex II 3G Ex ec IIC T3 Gc	K72+K82
		Ex II 3D Ex h IIIC T120°C Dc		
Dust (D) Zone 22	IIIB	Ex II 3G Ex h IIB T4 Gc	Ex II 3D Ex tc IIIB T120°C Dc	K74+K81
		Ex II 3D Ex h IIIB T120°C Dc		

SIMOGEAR The new integrated explosion-protected geared motors

Easy to order with one MLFB:

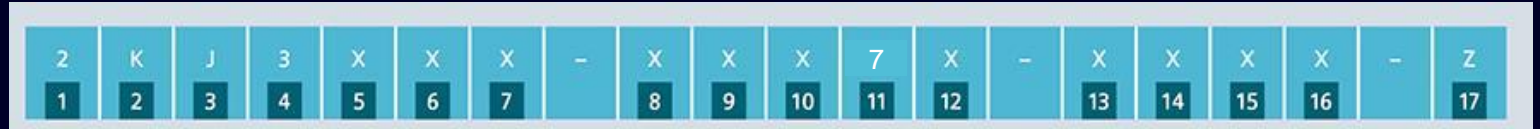

7 = explosion-protected motors (Zone 2 and 22)

ZF39-MB80ZMQ4P SIMOGEAR geared motor

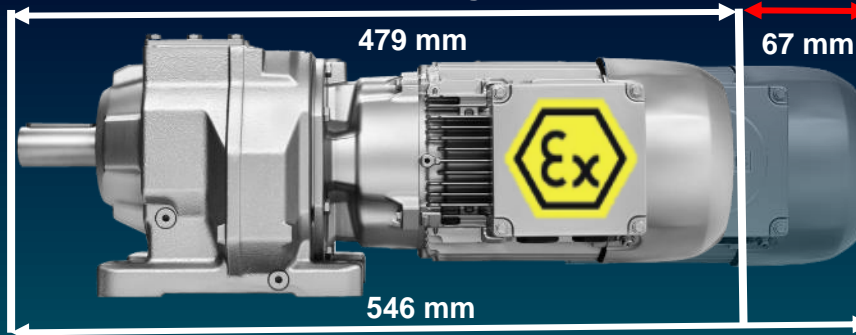

ZF39-K4-80 - SIMOGEAR gearbox with Adapter K4 and IEC SIMOTICS Motor

Z-Option

- K72 for Zone 2 (Gas)
- K74 for Zone 22 (Dust)

Explosion sphere	Explosion group	Marking Type of protection gearbox	Marking Type of protection motor	Order code
Gas (G) Zone 2	IIB	Ex II 3G Ex h IIB T4 Gc Ex II 3D Ex h IIB T120°C Dc	Ex II 3G Ex ec IIB T3 Gc	K72+K81
	IIC	Ex II 3G Ex h IIC T4 Gc Ex II 3D Ex h IIC T120°C Dc	Ex II 3G Ex ec IIC T3 Gc	K72+K82
Dust (D) Zone 22	IIIB	Ex II 3G Ex h IIB T4 Gc Ex II 3D Ex h IIB T120°C Dc	Ex II 3D Ex tc IIIB T120°C Dc	K74+K81

SIEMENS
S FDUN1/255255701
1P 2KJ3408-9EA73-0HL1-Z
KAZ89-MB100ZLR4P-1

185kg Tamb -20...+40°C (IM)M4-B/M1-B/80
II 3G Ex h IIB T4 Gb
II 3D Ex h IIB T120°C Db

K-ID: 1234567890
16.0L OIL CLPH1 VG460 i: 206.32
n2: 6.86r/min | T1max: 9.5Nm n1max: 1415r/min
T2: 1341Nm fB: 1.2

SIEMENS AG, Bahnhofstr. 40, DE-72072 Tuebingen / Made in Germany

SIEMENS
S FDUN1/255255701
1P 2KJ3408-9EA73-0HL1-Z
KAZ89-MB100ZLR4P-1

185kg Tamb -20...+40°C (IM)M4-B/M1-B/80
II 2G Ex h IIB T4 Gb
II 2D Ex h IIB T120°C Db

K-ID: 1234567890
16.0L OIL CLPH1 VG460 i: 206.32
n2: 6.0r/min | T1max: 9.5Nm n1max: 1415r/min
T2: 1341Nm fB: 1.2

SIEMENS AG, Bahnhofstr. 40, DE-72072 Tuebingen / Made in Germany

SIMOGEAR The new integrated explosion-protected geared motors

Easy selection and configuration in DTK

Product group	<input type="radio"/> Geared motor	Motor selection	Line voltage range	3AC 380-480V (Standard)
	<input checked="" type="radio"/> Geared motor explosion-protected direct mounting		Converter operation	<input type="radio"/> Yes <input checked="" type="radio"/> No
	<input type="radio"/> Gearbox with adapter		Converter	-
	<input type="radio"/> Gearbox with adapter explosion-protected		Motor efficiency / specials	ATEX Zone 2 (gas) / 1MB three-phase motor Premium efficiency IE3
			Number of poles / Reference motor speed	ATEX Zone 2 (gas) / 1MB three-phase motor Premium efficiency IE3
				ATEX Zone 22 (dust) / 1MB three-phase motor Premium efficiency IE3
		Certificates	Specification	<input checked="" type="radio"/> CE (Europe / other countries) <input type="radio"/> (N68) Without CE mark for export outside EEA
			(N38) UL-R/CSA (North America)	<input type="checkbox"/>
			(N32) Ex version for the Chinese market (CCC)	<input type="checkbox"/>
			(N30) EAC (Russia)	<input type="checkbox"/>



Easy to select in DTK

- System responsibility in production factory
- Easy to handle and deliver as one certified product
- Temperature calculation is checked by DTK with Hydra

SIMOGEAR The new integrated explosion-protected geared motors

Operating instructions

[Operating instructions](#)



[Operating instructions](#)



The declaration of conformity is provided in the Appendix to the operating instructions

SIMOGEAR The new integrated explosion-protected geared motors Catalog



Catalog D 50.1: SIMOGEAR Geared Motors

New revision within 2021

Catalog MD 50.11: SIMOGEAR Gearboxes with adapter



Catalog D 81.1: SIMOTICS GP, SD, XP, DP Low-Voltage Motors

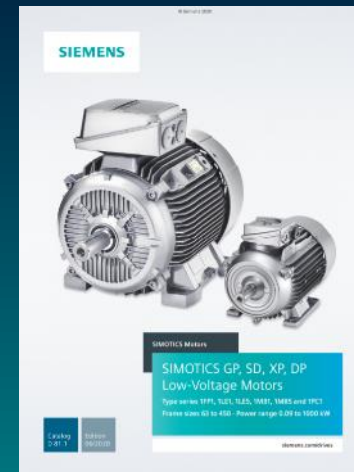

SIMOGEAR The new integrated explosion-protected geared motors

Converter operation explosion-protected geared motors with frequency converter

Option	
P94	Converter duty SINAMICS G120 PM240-2, operation with reduced voltage and torque (LVM B40) - 20%
P95	Converter duty SINAMICS S120 ALM, operation with same voltage but slightly with reduced power (LVM B41) - 7%
P96	Converter duty SINAMICS G120D PM250, operation with reduced voltage and torque - 35%

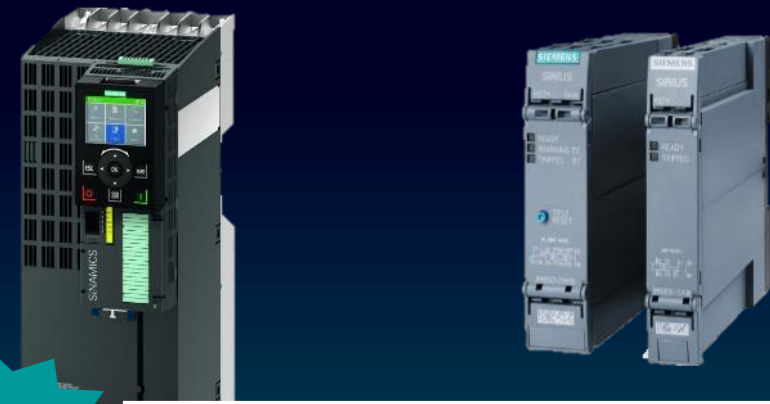

The temperature should be observed with PTC. For evaluation, SIRIUS 3RN2 thermistor motor protection relays for hazardous areas should be used.

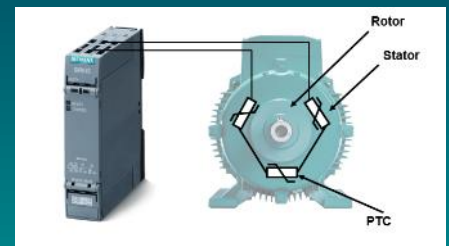
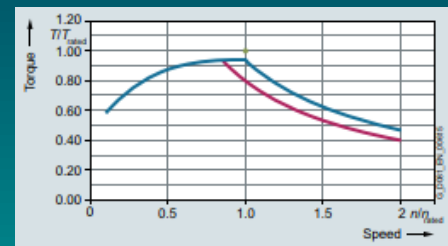
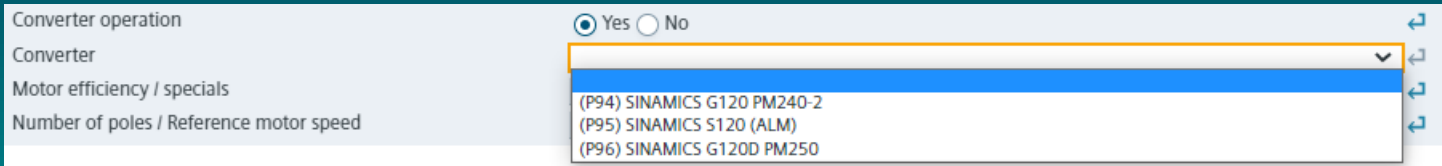

SIMOGEAR The new integrated explosion-protected geared motors

1. Temperature monitoring with PTC as a standard for converter operation
2. SIRIUS 3RN2... thermistor motor protection relay
3. Cable gland always included
4. Encoder: LeineLinde 841 9000 13 (Q10)
5. DC connection available only.

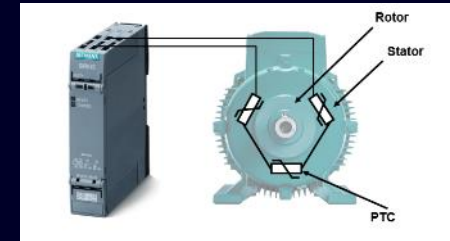

*The rectifier cannot be placed in the motor terminal box.
Brake rectifier is not a part of our supply.
See the cabinet rectifier for an example:
50001 MURRELEKTRONIK ACTIVE BRAKE RECTIFIER*

Brake selection and options	
with Brake:	<input checked="" type="radio"/> Yes <input type="radio"/> No
Brake type (torque at 100 rpm)	<input type="text" value=""/>
Rectifier	DC voltage control (without)
Supply voltage	<input type="text" value=""/>
Brake design	<input type="text" value=""/>
Manual brake release lever	<input type="checkbox"/>
(C10) increased corrosion protection	<input type="checkbox"/>
(C06) friction lining, wear-resistant	<input type="checkbox"/>
(C04) Microswitch for release monitoring	<input type="checkbox"/>
(C80) Brake cable Protection	<input type="checkbox"/>

Dropdown menu options:

- (C66) 24V DC +10%
- (C53) 180V DC +10%
- (C64) 205V DC +10%

SIMOGEAR The new integrated explosion-protected geared motors

1. Gearbox inspection - temperature check

System Gearbox Motor Additional Options Gearbox inspection ATEX checklist KB version: 20.9

Configured geared motor

Gearbox type	Bevel gearbox
Gearbox	B49
Transmission ratio	53.89
Mounting position	(D11) M1 output side A
Mounting type gearbox	Foot-mounted design
Output shaft type	Solid shaft with feather key
Output shaft dimensions	V35 x 70
Output shaft bearing	Standard bearing
Gearbox oil	(K07) Synthetic oil CLP PG VG220
Output shaft sealing	Standard sealing

Motor rating

Motor	MB80MH4P
Motor power [kW]	0.550
Motor speed [rpm]	1440
Rated motor torque 50 Hz [Nm]	3.64
Ventilation	Standard fan

Inspection

Environment temperature [°C]	-20 ≤ 40 ≤ 40
Input power [kW]	0.55
Input speed [rpm]	1440
Output torque [Nm]	196.57
Output speed [rpm]	26.721
Oil temperature [°C]	115.65

The maximum permissible oil temperature of 90 °C was exceeded

2. Gearbox inspection - approval of the values

Thermal load: 62.19 %; Mechanical load: 83.33 %

System Gearbox Motor Additional Options Gearbox inspection ATEX checklist KB version: 19.42

Operating environment

ATEX Zone	(K72) Zone 2
Maximum ambient temperature	-20 ... +40 °C
Explosion Group	IIC
(K77) Temperature class <- T3	<input checked="" type="checkbox"/>
(K75) Maximum permissible surface temperature <- 120°C	<input type="checkbox"/>

Geared motor data

Type designation	K69-MB112ZMKB4P-1
Mounting position	(D11) M1 output side A
Transmission ratio	16.88
Max. input power [kW]	4.00
Max. input speed [rpm]	1460
Base frequency [Hz]	50

Information

Operating mode	Line operation
Converter	-

ATEX markings

ATEX marking order code	(K82) Ex II 3G Ex h IIC T4 Gc, II 3D Ex h IIIC T120°C Dc
ATEX-marking gas	Ex II 3G Ex h IIC T4 Gc
ATEX-marking dust	Ex II 3D Ex h IIIC T120°C Dc
ATEX marking motor	Ex II 3G Ex ec IIC T3 Gc

Confirmation

ATEX-Message	A thermal calculation is needed!
--------------	----------------------------------

I confirm ATEX statements

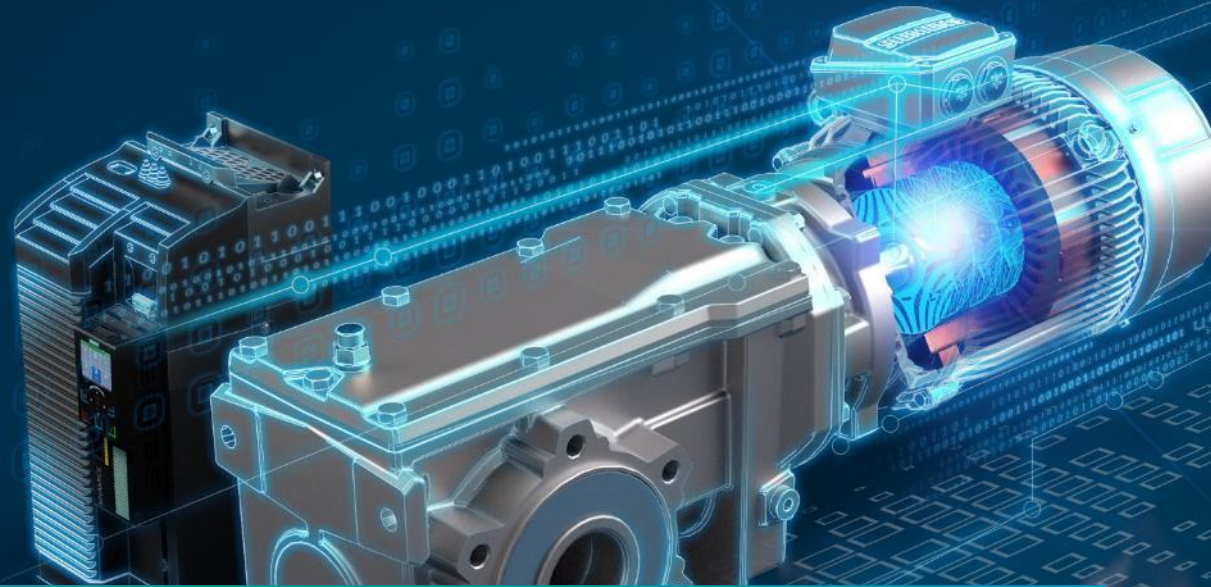

SIMOGEAR reluctance geared motor

SIMOGEAR reluctance geared motor

Position in the geared motor portfolio

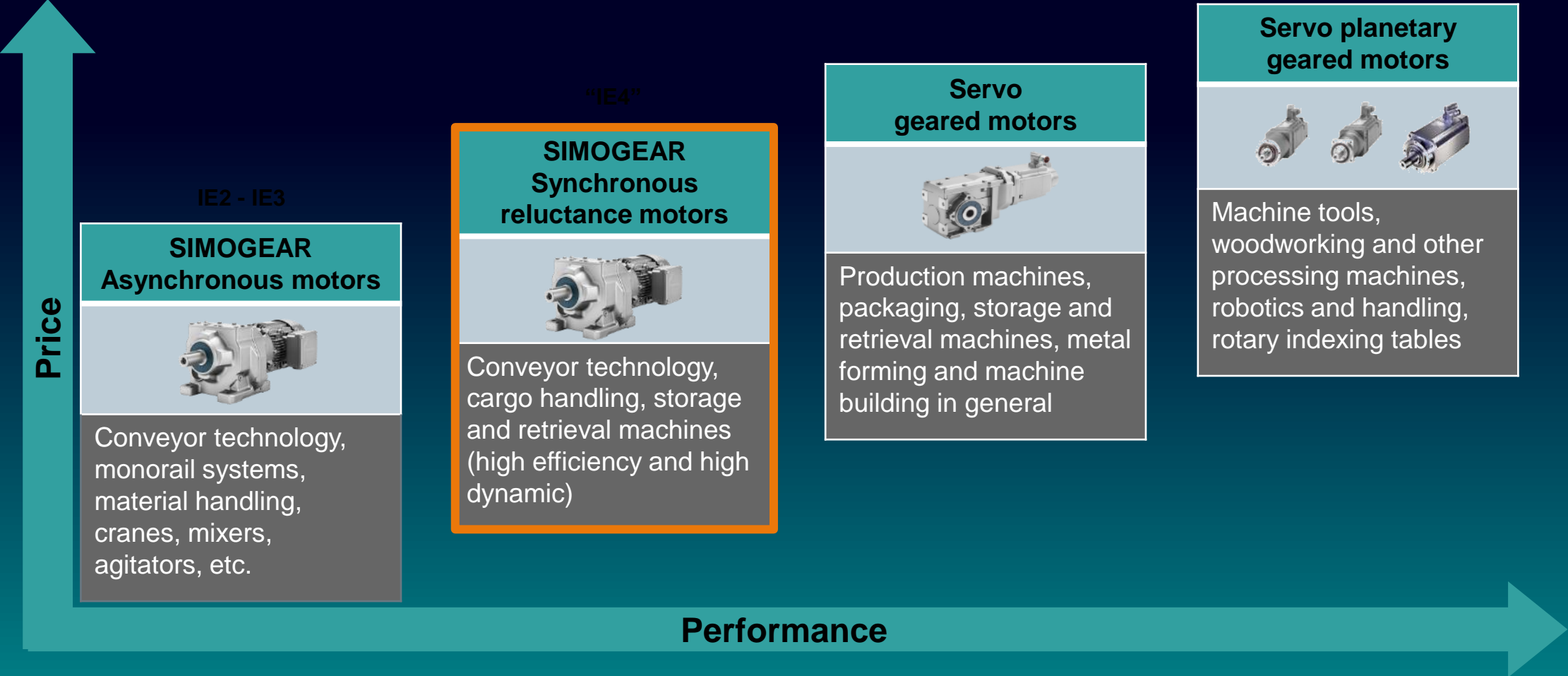

SIMOGEAR reluctance geared motor

Compact. Rugged. Energy efficient.



Energy efficient – Cost optimized – Highly dynamic

Features / Function		Benefits
Efficiency	▶	<ul style="list-style-type: none">• Motor-efficiency higher than comparable IE4 induction motors, higher efficiency in partial load
Performance	▶	<ul style="list-style-type: none">• Low inertia allows high dynamics, sensor less vector control• Precise speed even without encoder, no need for encoder in many applications
Thermal behavior	▶	<ul style="list-style-type: none">• High permanent overload possible in high speed range
No permanent magnets	▶	<ul style="list-style-type: none">• Environmentally friendly• Independent on rare-earths
Serviceability	▶	<ul style="list-style-type: none">• Modular system (gearbox, motor and inverter) allows efficient repairs• Easier to service compared to permanent magnet motors

SIMOGEAR reluctance geared motor

Overview

SIMOGEAR reluctance geared motor High efficient drive system

Technical specifications

Power range	▶	AH80 – AH112 (0.55 – 4kW)
Overload Capability	▶	Up to 200%
Certificates	▶	CE, UL/CSA, CCC (in preparation)
Gearboxes	▶	Helical, Parallel shaft, Bevel, Helical worm
Tools	▶	DT-Configurator, SIZER



SIMOGEAR reluctance geared motor

Available with SINAMICS G110M, G115D, G120D, G120 and S120

SINAMICS G115D



Industries

- Warehouse and Distribution Logistics
- Baggage and Cargo Handling
- Postal and Package Distribution Automotive

Typical fields of application

- Roller, chain and belt conveyors



SINAMICS S120



Industries

storage and retrieval machines

Typical fields of application

- continuous material webs and clocked high-dynamic processes – such as is the case for presses and roller feeds



SINAMICS G120D



Industries

- Roller, chain, belt and skid conveyors in the automotive industry

Typical fields of application

- Roller, chain and belt conveyors
- hoisting gear
- Scissor Lift Table
- Monorail conveyors



SINAMICS G120



Industries

- Conveyor technology Roller, chain, belt and skid conveyors in different industry

Typical fields of application

- Control cabinet based conveyor technology with increased communication needs



SIMOGEAR reluctance geared motor

Energy efficiency at rated load and partial load

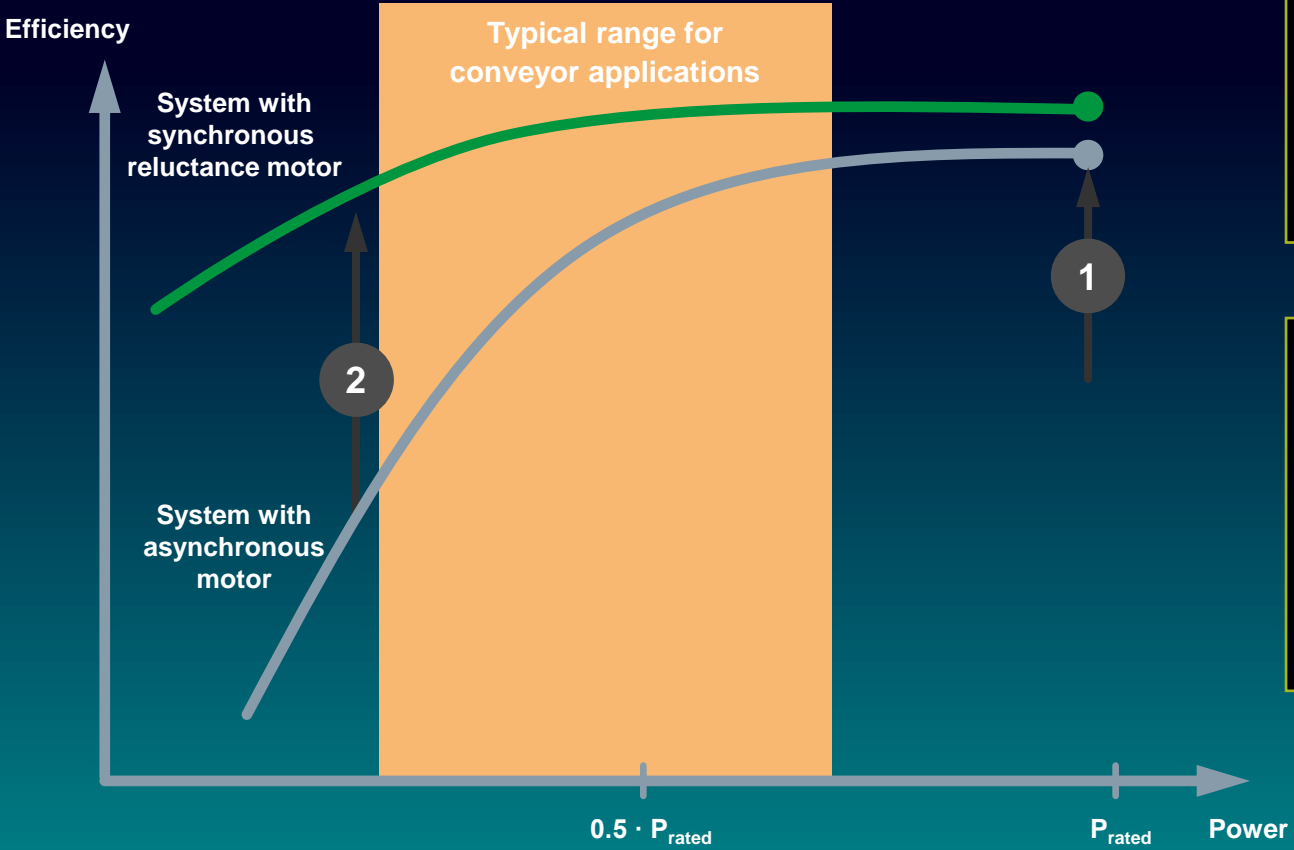

+

- The efficiency of the drive system with the reluctance motor at rated load is higher than the efficiency of the drive system with IE4 asynchronous motor

+

- The efficiency of the drive system with the reluctance motor at partial load is much higher than the efficiency of the drive system with IE4 asynchronous motors

*) Minimum efficiency acc. IEC 60034-30-1. Converted to inverter operation acc. DIN EN 50598-2 (chapter 5.3.2.6: additional losses depending on harmonics)

SIMOGEAR reluctance geared motor

Dynamic - Low intrinsic moment of inertia

Average rel. intrinsic moment of inertia of reluctance motors
0,55 - 4 kW

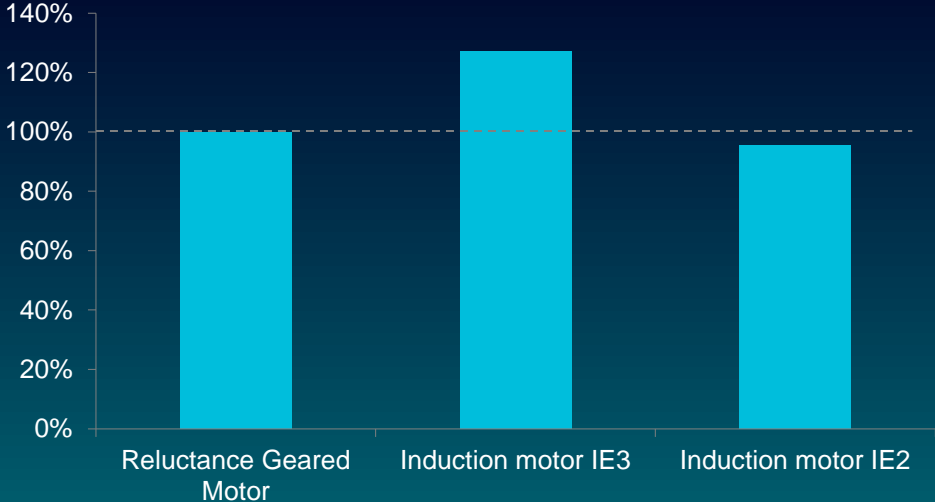

Rel. intrinsic moment of inertia
reluctance motors 0.55 - 4 kW compared to IE3

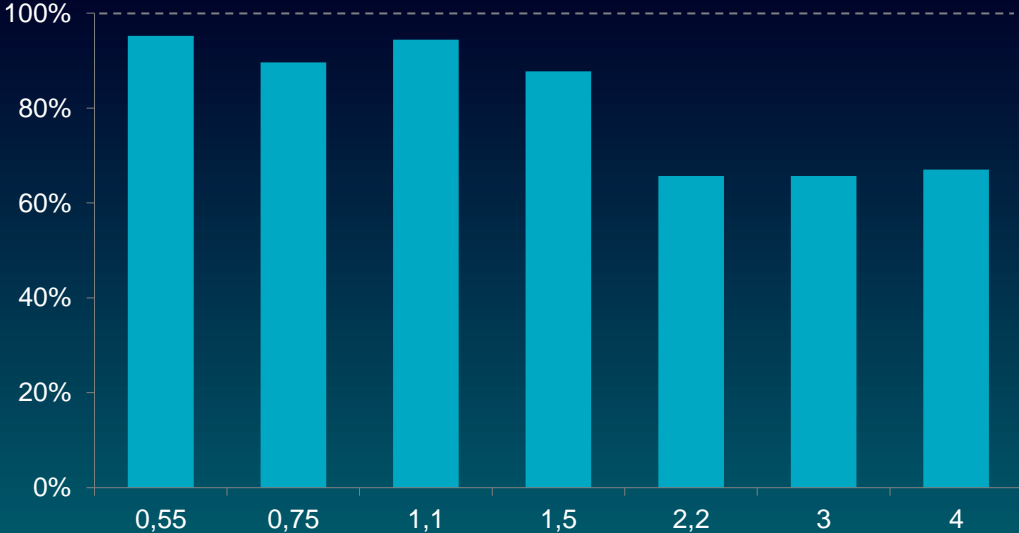

Due to the synchronous reluctance technology the intrinsic moment of inertia is lower than IE3 and IE4 induction motors' moment of inertia.

SIMOGEAR reluctance geared motor

Thermal behaviour - High reliability of operation due to low motor temperature

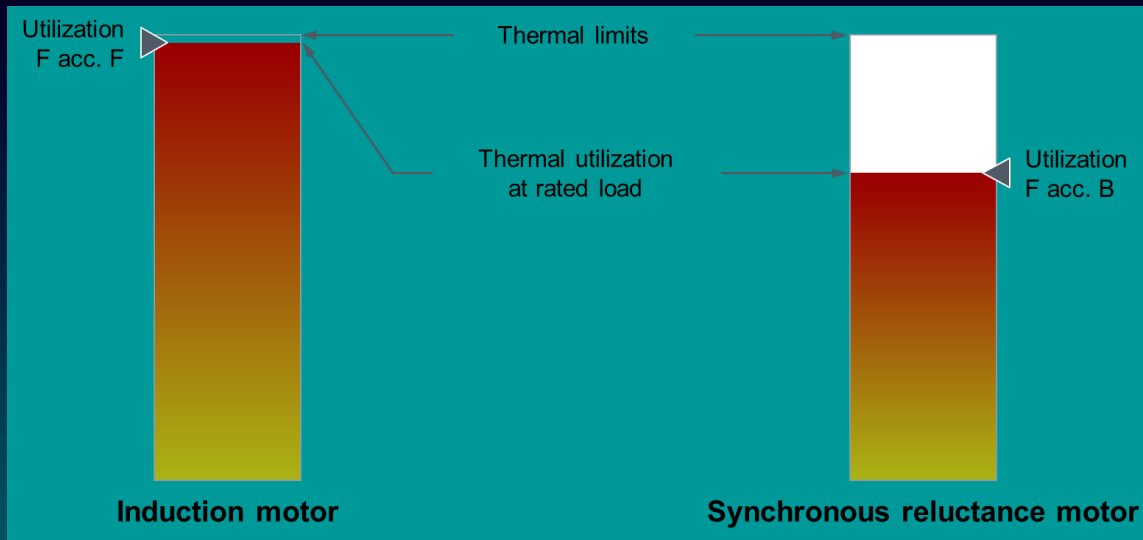

Thermal reserves +

- Synchronous reluctance motors have almost no losses in the rotor, for that reason there are higher thermal reserves compared to asynchronous motors

No torque derating at low speeds +

- With the thermal reserves synchronous reluctance motors can be operated down to 10% of rated speed with rated torque, a torque reduction is not necessary

High overload capability Service Factor +

With the thermal reserves synchronous reluctance motors can be operated with a higher overload, also in a low speed range.

SIMOGEAR reluctance motors provide high thermal reserves due to lower losses in the rotor

SIMOGEAR reluctance geared motor

Compact. Rugged. Energy efficient.

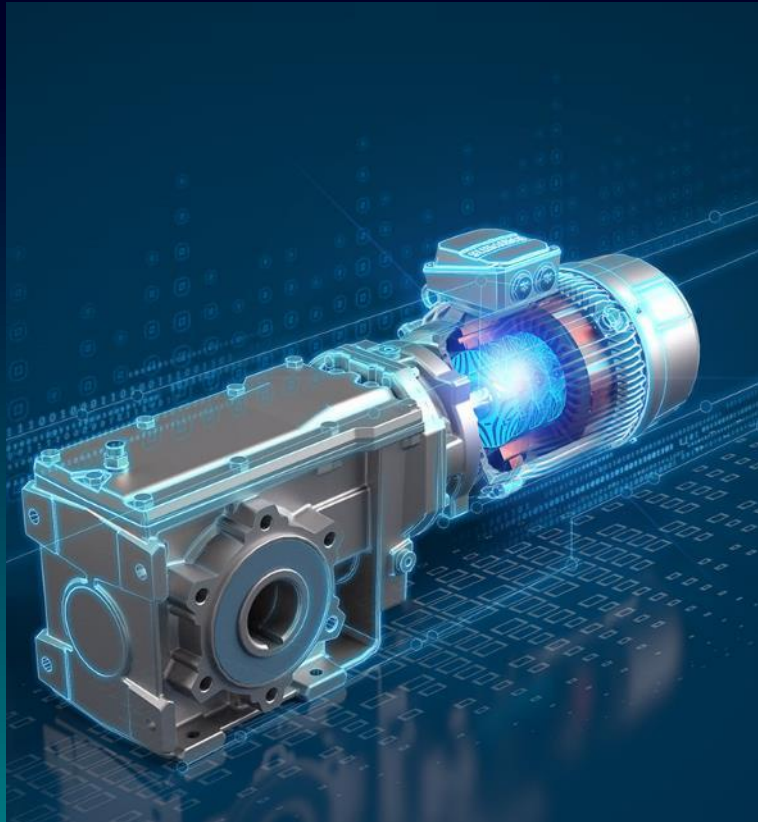

Energy efficient – Cost optimized – Highly dynamic

Features / Function		Benefits
Efficiency	▶	<ul style="list-style-type: none"> • Motor-efficiency higher than comparable IE4 induction motors, higher efficiency in partial load
Performance	▶	<ul style="list-style-type: none"> • Low inertia allows high dynamics, sensorless vector control • Precise speed even without encoder, no need for encoder in many applications
Thermal behaviour	▶	<ul style="list-style-type: none"> • High permanent overload possible in high speed range
No permanent magnets	▶	<ul style="list-style-type: none"> • Environmentally friendly • Independent on rare earths
Encoderless	▶	<ul style="list-style-type: none"> • Cheaper • Without slip



SIMOGEAR

Ecodesign Regulation (EU)

2019/1781 as of July 1, 2021

Eco design

SIMOGEAR geared motor

Motor product cancellation

Ecodesign Regulation (EU) 2019/1781 as of **July 1, 2021**

<https://support.industry.siemens.com/cs/ww/en/view/109793259>

According to the Regulation of the European Union 2019/1781, SIMOGEAR motors affected by the definition of the Ecodesign Regulation are to be **discontinued**.

The Regulation applies to the 3~ asynchronous motors

- Power 0.12 kW to 1000 kW
- Pole numbers 2, 4, 6 and 8
- Line frequency 50 and 60 Hz or 50/60 Hz
- Designed for continuous operation in operating modes S1, S3 \geq 80%, S6 \geq 80%.

Design IE3: from 0,75 to 1000 kW

Design IE2: from 0,12 to 0,55 kW

I Díky za pozornost

Ing. Vladimír Mýlek

Siemens s.r.o.
RC-CZ DI MC GMC
28.Října 150/2663
702 00 Ostrava

Telefon +420 724 057 093

E-mail vladimir.mylek@siemens.com

www.siemens.cz/pohony