

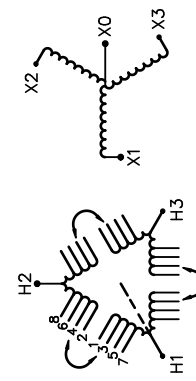

REVISION	DATE	BY	DATE	BY
		DRAWN	17/02/17	MA
		CHEK'D		
		VERIF'D		

Confidential - Property of <b>Siemens Industry, Inc.</b>	
CUSTOMER	
ORDER NO.	DWG. NO.
	3F3Y750CD16
SH 1 OF 3	

# SIEMENS

<p>CATALOG NO. 3F3Y750CD16</p> <p>SERIAL NO. SERIES H</p> <p>750 kVA 60 Hz 3 PHASE</p> <p>6.1 % IMP AT 170 °C</p> <p>150 °C RISE 30 °C AVG. AMBIENT</p> <p>220 °C TEMP CLASS 40 °C MAX. AMBIENT</p> <p>PRIMARY ( H1 H2 H3 ) 480 V 10 kV BIL</p> <p>SECONDARY( X0 X1 X2 X3 ) 208Y/120 V 10 kV BIL</p> <p>WINDING MATERIAL CU</p> <p>ENCLOSURE TYPE 3R WEIGHT 4250LBS</p> <p>ENERGY EFFICIENCY EXCEEDS CSA DOE 10 CFR PART 431:2016 C802.2-2012</p> <p>SPACINGS BETWEEN ANY VENTILATED ENCLOSURE PANEL AND ANY ADJACENT WALL SHALL BE A MINIMUM OF 12 INCHES</p> <p>SEISMIC QUALIFICATIONS, OSP-0136-10 IBC 2012/ASCE 7-10 SDS&lt;=2.0g Z/H=1 IP=1.5</p> <p>SUITABLE FOR INDOOR OR OUTDOOR LOCATIONS BEFORE HANDLING, INSTALLING AND OPERATING; SEE INSTRUCTION MANUAL</p> <p>NEMA Class ANN Dry Type Transformer Siemens Industry, Inc. Norcross, GA <small>dsu0086e</small></p>	 <p>VOLTS CONNECT</p> <p>504 1-2</p> <p>492 2-3</p> <p>480 3-4</p> <p>468 4-5</p> <p>456 5-6</p> <p>444 6-7</p> <p>432 7-8</p>	<p>TYPE K</p>  <p>UL LISTED</p>  <p>DRY TYPE TRANSFORMER E112313 LR 3902</p> <p>SEISMIC QUALIFICATIONS, FLOOR MOUNT ONLY OSP-0136-10 IBC 2012/ASCE 7-10 SDS&lt;=2.0g Z/h=1 IP=1.5</p>
---	---	---



3F3Y750CD16

FRONT VIEW

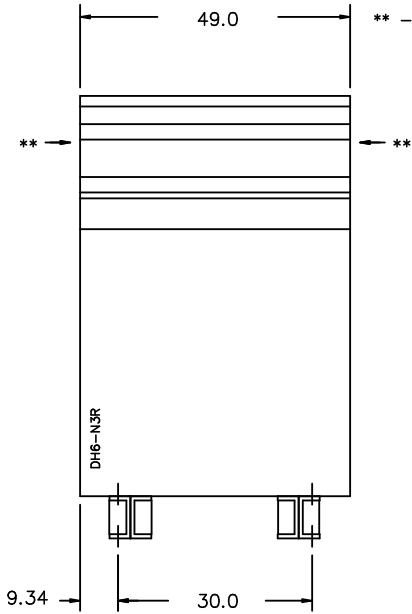

\*\* - Recommended cable entry locations only  
cutouts & gland plates not provided.

SIDE VIEW

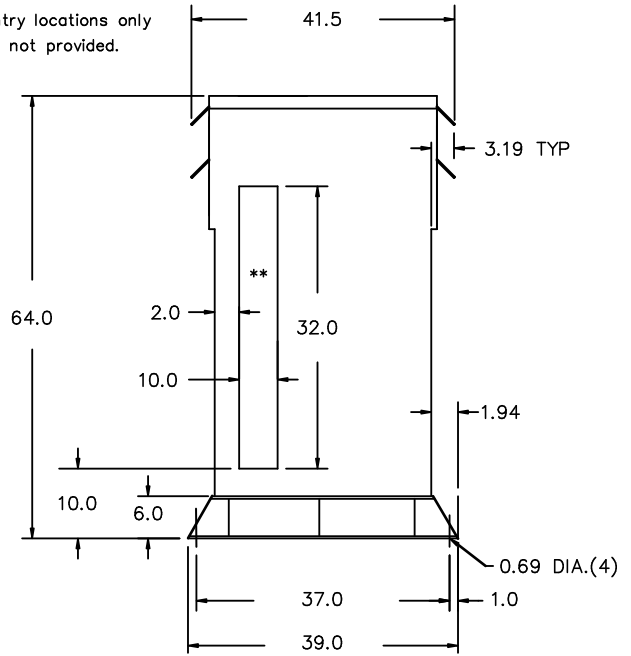

All Dimensions in inches

ENCLOSURE COLOR : ANSI 61 GREY - OUTDOOR

H.V.1. TERMINAL DETAIL

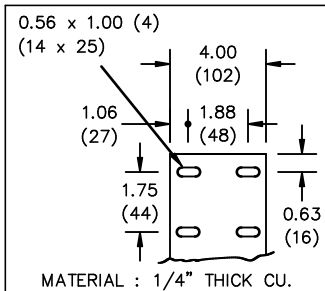

L.V.1. TERMINAL DETAIL

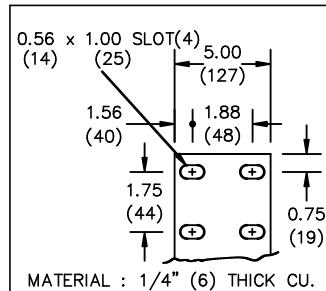

CUSTOMER NOTES:

- HV1 TERMINATED AT TOP FRONT
- LV1 TERMINATED AT BOTTOM FRONT

Confidential - Property of  
Siemens Industry, Inc.

REVISION	DATE	BY	DATE	BY
		DRAWN	17/02/17	MA
		CHEK'D		
		VERIF'D		

CUSTOMER

ORDER NO.

DWG. NO.

3F3Y750CD16

SH 2 OF 3

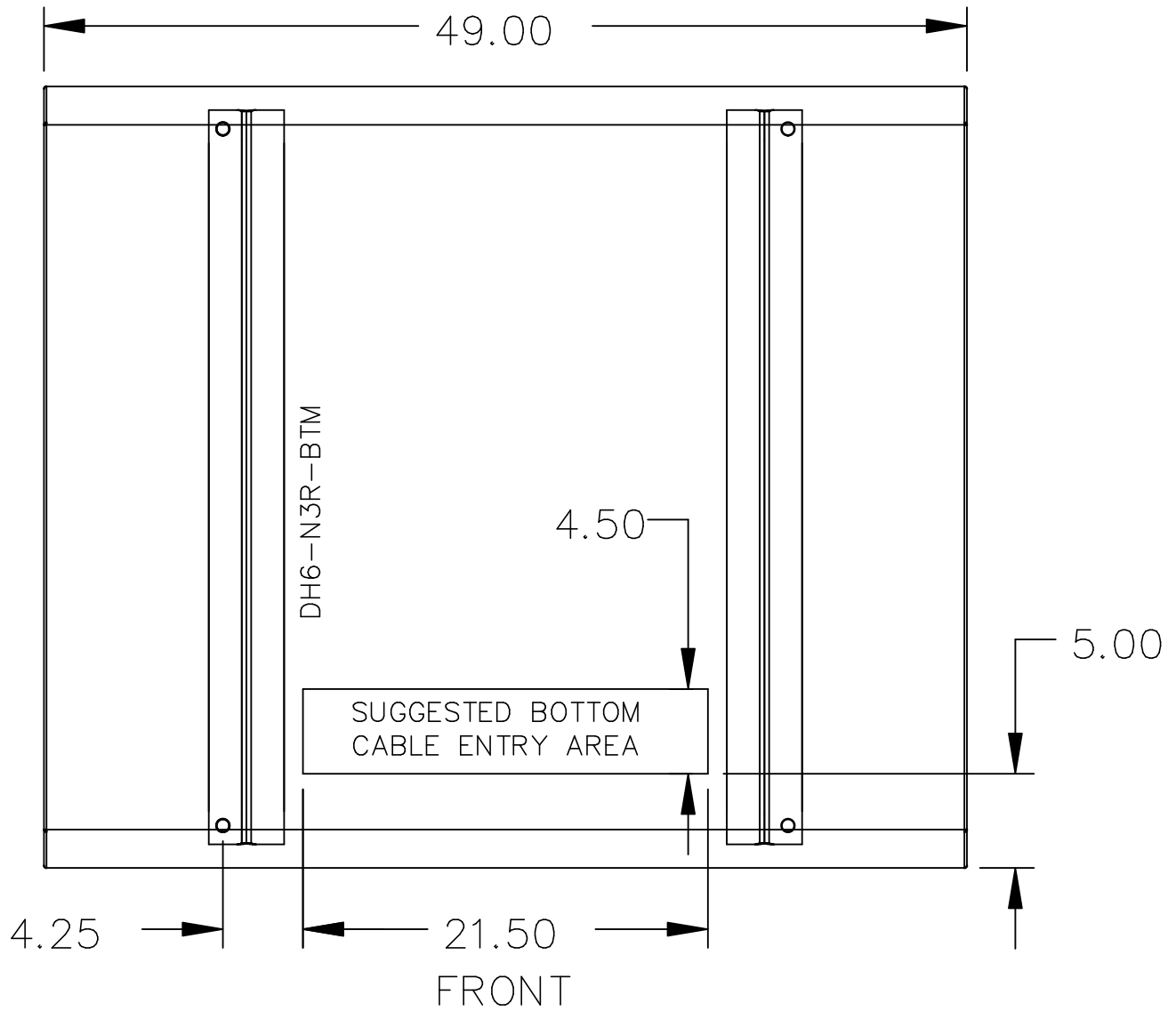

NOTE:  
 WHEN BOTTOM CABLE ENTRY IS OPTED, THE SPACE USED FOR CONDUITS IN THE FRONT OF THE TRANSFORMER SHOULD NOT OBSTRUCT MORE THAN 50% OF THE FRONT AIR INTAKE AREA DEFINED BETWEEN THE BOTTOM PLATE AND THE SUPPORTING LEGS.  
 SEE MANUAL FOR ADDITIONAL INFORMATION

Confidential - Property of  
 Siemens Industry, Inc.

REVISION	DATE	BY	DATE	BY
		DRAWN	17/02/17	MA
		CHEK'D		
		VERIF'D		

CUSTOMER	
ORDER NO.	DWG. NO. 3F3Y750CD16
SH 3 OF 3	