

**SIEMENS**



Document No: 10071599

# DigiTRONf Single Connectors Installation, Operations and Maintenance Manual

Protection, Storage, Shipment, Unpacking, Deployment  
& Maintenance Instructions

[www.siemens.com/energy/connector-operations-manual](http://www.siemens.com/energy/connector-operations-manual)

This page records the revision status of the entire document and its authorisation for issue. When a page or pages of the document are revised, the number of the page affected will be entered in the Page Affected/Remarks Column and a vertical margin line will appear against the latest amended text.

## DigiTRONf Single Connectors Installation, Operations and Maintenance Manual

The contents of this document are confidential and must not be disclosed to any third party without prior consent in writing from Siemens Subsea Connectors a division of Siemens plc.

3	R Wyatt	26/02/2020	J Hardisty	26/02/2020	Safety warning added regarding differential pressure rated products not to be used for fixed pressure vessel installations.
2	R. Armistead	08/06/17	M. Tucker	09/06/17	General update
1	R. Armistead	4/5/17	M. Tucker	4/5/17	First issue
	By	Date	By	Issue Date	Remarks / Pages Affected
Rev	Compiled		Checked		
© Siemens Subsea Connectors, (a division of Siemens plc), Subsea Excellence Centre, Ulverston, Cumbria, LA12 9EE, England					Page No. 2

## Contents

<b>1.</b>	<b>INTRODUCTION.....</b>	<b>4</b>
<b>2.</b>	<b>SCOPE .....</b>	<b>4</b>
<b>3.</b>	<b>ABBREVIATIONS .....</b>	<b>5</b>
<b>4.</b>	<b>HEALTH &amp; SAFETY .....</b>	<b>6</b>
<b>5.</b>	<b>PROTECTION, HANDLING AND SHIPMENT .....</b>	<b>6</b>
<b>6.</b>	<b>UNPACKING .....</b>	<b>9</b>
<b>7.</b>	<b>STORAGE .....</b>	<b>9</b>
7.1	Short Term Connector Storage .....	9
7.2	Long Term Connector Storage .....	9
7.3	Long Term Storage of Elastomers.....	9
<b>8.</b>	<b>REFERENCE DOCUMENTS .....</b>	<b>10</b>
<b>9.</b>	<b>INSTALLATION EQUIPMENT .....</b>	<b>10</b>
<b>10.</b>	<b>INSTALLATION NOTES.....</b>	<b>10</b>
<b>11.</b>	<b>STAB PLATE CONNECTORS .....</b>	<b>11</b>
<b>12.</b>	<b>BULKHEAD CONNECTORS.....</b>	<b>15</b>
<b>13.</b>	<b>ROV CONNECTORS, FLANGE MOUNT.....</b>	<b>17</b>
<b>14.</b>	<b>INSTALLATION OF FLYING ROV CONNECTORS .....</b>	<b>20</b>
14.1	Alignment and Mating.....	20
<b>15.</b>	<b>DUMMY / PARKING CONNECTORS .....</b>	<b>23</b>
<b>16.</b>	<b>INSTALLATION OF FLYING ROV DUMMY CONNECTORS .....</b>	<b>24</b>
16.1	Alignment and Mating.....	24
16.2	Mechanical Forces During Mating / De-Mating .....	25
16.3	Maximum Misalignment Values .....	25
16.4	Post Mating Checks (DigiTRONf ROV only):.....	25
16.5	ROV Mating / De-mating forces (DigiTRONf) .....	25
16.6	De-Mating .....	26
<b>17.</b>	<b>TEST CONNECTORS.....</b>	<b>27</b>
17.1	Testing of Single Connectors .....	27
<b>18.</b>	<b>FIBRE MARSHALLING UNIT .....</b>	<b>28</b>
<b>19.</b>	<b>DigiTRONf CONNECTOR SPECIFICATION .....</b>	<b>30</b>
<b>20.</b>	<b>MAINTENANCE.....</b>	<b>31</b>
20.1	Marine Growth and Calcareous Deposits .....	31
<b>21.</b>	<b>INFORMATION AND NOTES / HEALTH &amp; SAFETY FEEDBACK.....</b>	<b>32</b>
<b>22.</b>	<b>SIGN OFF SECTION .....</b>	<b>32</b>

## 1. INTRODUCTION

This manual details procedures for the following:  
Installation, Operation and Maintenance of DigiTRONf Connectors.

## 2. SCOPE

This manual details installation of the DigiTRONf family of connectors when supplied as loose connectors. Optical and mechanical specification of connectors is also detailed in this document.

**The back page includes a sign off point which must be completed by the user of this manual.**

Any information, records or Health and Safety feedback that needs to be detailed, can be recorded in the punch list at the rear of the document.

### 3. ABBREVIATIONS

<b>Assy</b>	<b>Assembly</b>
<b>API</b>	<b>American Petroleum Institute</b>
<b>BOM</b>	<b>Bill of Material</b>
<b>°C</b>	<b>Degree Celsius</b>
<b>CE</b>	<b>Community European</b>
<b>Comms</b>	<b>Communication Signal</b>
<b>CP</b>	<b>Cathodic Protection</b>
<b>dB</b>	<b>Decibel</b>
<b>DWG</b>	<b>Drawing</b>
<b>FAT</b>	<b>Factory Acceptance Test</b>
<b>ISO</b>	<b>International Organization for Standardization</b>
<b>ITP</b>	<b>Inspection Test Plan</b>
<b>K</b>	<b>Kelvin</b>
<b>LTC</b>	<b>Long Term Cover</b>
<b>M</b>	<b>Metres</b>
<b>Max.</b>	<b>Maximum</b>
<b>MFG</b>	<b>Manufacturer</b>
<b>Min.</b>	<b>Minimum</b>
<b>No.</b>	<b>Number</b>
<b>ROV</b>	<b>Remotely Operated Vehicle</b>
<b>SI</b>	<b>Standard International</b>
<b>SRT</b>	<b>Site Received Test</b>
<b>SST</b>	<b>Stainless Steel</b>
<b>TBD</b>	<b>To Be Defined</b>
<b>UNS</b>	<b>Unified Numbering System for Metals and Alloys</b>

## 4. HEALTH & SAFETY

	<p><b>Danger of release of stored pressure.</b></p> <p>DigiTRON Products are designed for, and intended only for use in subsea applications e.g. in subsea control systems, and associated activities such as topside testing and commissioning of such systems.</p> <p>The DigiTRON Products are not designed to comply with the requirements of the Pressure Equipment Directive (2014/68/EU) and therefore, <b>are not intended for incorporation into fixed top-side or land-based pressure vessels.</b></p>
---	--

Manual Handling, Lifting and Carrying are known to be the largest contributors to occupational ill-health. Ensure that mechanical handling aids are used if manual handling is inappropriate. Where manual handling is considered appropriate for the task safe lifting guidelines must be followed, e.g. adopt correct posture, consider team lifting, employ safe lifting technique, etc.

Only competent persons are permitted to perform tasks without supervision, if in doubt ask. Good Housekeeping avoids Slips Trips and Falls, keep your area clean and tidy.

It is the operator's responsibility to comply with current Company & regional health and safety legislation. Caution shall be exercised during assembly to ensure that fittings and hydraulic / pneumatic equipment are properly installed.

In the event of a safety incident or any safety improvement suggestions please contact the Health and Safety Department at [prodsafe.gb@siemens.com](mailto:prodsafe.gb@siemens.com) and/or complete and return the punch list in section 21.

Glass fibres embedded in skin or eye, or inhaled, potentially entering blood stream can cause serious medical conditions. Operator must therefore be trained in the handling of optical fibre. When cleaving, all sharps must be disposed of into a sharps bin immediately after breaking off the fibre end. Do not leave any fibre sharps on benches or on the cleaver. Where possible, work on a black surface to enable sharps to be more easily seen. Do not attempt to vacuum up the sharps. Take extreme care when handling stripped (i.e. bare) fibre and do not touch the cut ends of any fibre, stripped or not. Wash hands before eating or smoking. Wear safety glasses when cleaving. Fit the rubber bung in the sharps bin when not in use.

## 5. PROTECTION, HANDLING AND SHIPMENT

Siemens Subsea optical connectors are manufactured primarily from Super Duplex stainless steel (UNS S32550), and as such are designed to withstand harsh saliferous environments. However, the connector is susceptible to mechanical damage if not adequately protected. Dust caps or Acetal protective caps are fitted to all Siemens Subsea connectors before transport. Caps are recommended to remain in place until connectors are deployed subsea.

The connectors are generally relatively small items of equipment, and therefore, can be shipped singularly or in multiples. Care should be taken to protect the connector with either Instapak (or similar), bubble wrap or similar wrapping materials to avoid surface damage during transit. If large numbers are shipped in one consignment a suitably reinforced box will be necessary to withstand the weight. Dust caps or Acetal protective caps must be fitted at all times during transport.

**See next page for images.**

**WARNING:** Please refer to product packaging for accurate lifting weight and ensure the appropriate lifting equipment and PPE are used during handling operations.

## ACCEPTABLE PACKAGING FOR SHIPMENT



*Instapak (or similar)*

*bubble wrap (or similar)*

## UNACCEPTABLE PACKAGING



If storage is carried out in saline conditions, e.g. on a ship's deck or hold, then protective caps should be used to protect a receptacle connector and a protective cap to protect a plug connector. Bulkhead type connectors with exposed tailing fibres should be packed and shipped in a suitably sized box to allow adequate space for the tailing fibre management system to be stored without bending or kinking. If the connectors are assembled onto hoses these must be suitably coiled and secured with tape to prevent uncoiling during transit. The following bend radii are recommended for storage/transport of hoses.

AquaTRON 50, TC6A-700 – Minimum inside bend radii - 125mm

Connectors are designed & qualified to withstand vibration that occurs during transportation and to withstand being dropped from a height of 2m whilst in packaging. Any connector-specific handling and transport advice is contained within the appropriate section further on in this document. Ensure that mechanical handling aids are used whenever possible to avoid manual handling.



## 6. UNPACKING

Remove wrapping material taking care to inspect for any surface damage or items that may have become separated from the connector, such as 'O' seals. Do not use a knife to cut the wrapping material, as this may cause damage to any elastomeric parts of the connector. Do not remove protective caps until connectors are ready for installation. On removal do not allow the hoses to drag over the edges of the packing crate. Connectors supplied in boxes must be stored in the box.

## 7. STORAGE

### 7.1 SHORT TERM CONNECTOR STORAGE

(Non-controlled warehouse / exposed storage and transportation)

Prior to installation /deployment the connectors are sensitive to environments where grit and dirt are present. To prevent ingress of the above, they should be stored in a clean dry area and be protected by their protective wrapping material or similar.

Protective caps must be fitted if supplied. (also refer to section 5)

No carbon steel must be present in the storage of the products.

**Please note;** Maximum storage temperature takes into account solar gain. Surface temperature must not exceed 70°C. Suitable protection must be used to ensure maximum storage temperature is not exceeded.

### 7.2 LONG TERM CONNECTOR STORAGE

The connectors must be stored in a clean dry area and be protected by bubble wrap or similar. Suitable protection caps must be fitted and the storage temperature should be between -40°C and 70°C. Humidity of the store room should be below 75%. Very moist or very dry conditions should be avoided. The Plug connector should be protected from strong sunlight and strong artificial light with a high ultra violet content. The connectors should not be allowed to come into contact with solvents, oil, greases or any other semi-solid materials.

No carbon steel must be present in the storage of the products.

**Please note;** maximum storage temperature takes into account solar gain. Skin temperature must not exceed 70°C. Suitable protection must be used to ensure maximum storage temperature is not exceeded.

### 7.3 LONG TERM STORAGE OF ELASTOMERS

For the recommended storage of elastomeric components e.g. termination sleeves and cable boots, please refer to Siemens document MH006 - Procedure for Storage and Handling of Elastomeric Materials.

## 8. REFERENCE DOCUMENTS

<b>MH006</b>	Siemens Subsea document - Procedure for Storage and Handling of Elastomeric Materials.
<b>T16561</b>	DigiTRONf Compliant Mount ROV Interface
<b>10024652</b>	DigiTRONf Bulkhead Interface

## 9. INSTALLATION EQUIPMENT

Tools Required for installation:

1. ¼ inch drive torque wrench 0-25 Nm – with Metric Allen key drive
2. Loctite 243
3. Working class ROV with correct manipulator interface for Siemens paddle handle

## 10. INSTALLATION NOTES

DigiTRONf is a Fibre Optic Connector system, and as such, special consideration should be given to the management and protection of the fibre. Fibre, in its ribbonised or individual form is extremely fragile and can be damaged easily. Care should be taken that no objects are placed across exposed fibres. Fibre should be prevented from being bent below its minimum bend radius (typically 30mm). Where possible, fibre should remain in the provided fibre management trays until needed. Note that damage to the fibre may not be visible on the outer coatings. Under no circumstances should any part of the connector system be lifted by the fibre. If fibre damage is thought to have occurred, notify a Siemens engineer immediately.

## 11. STAB PLATE CONNECTORS

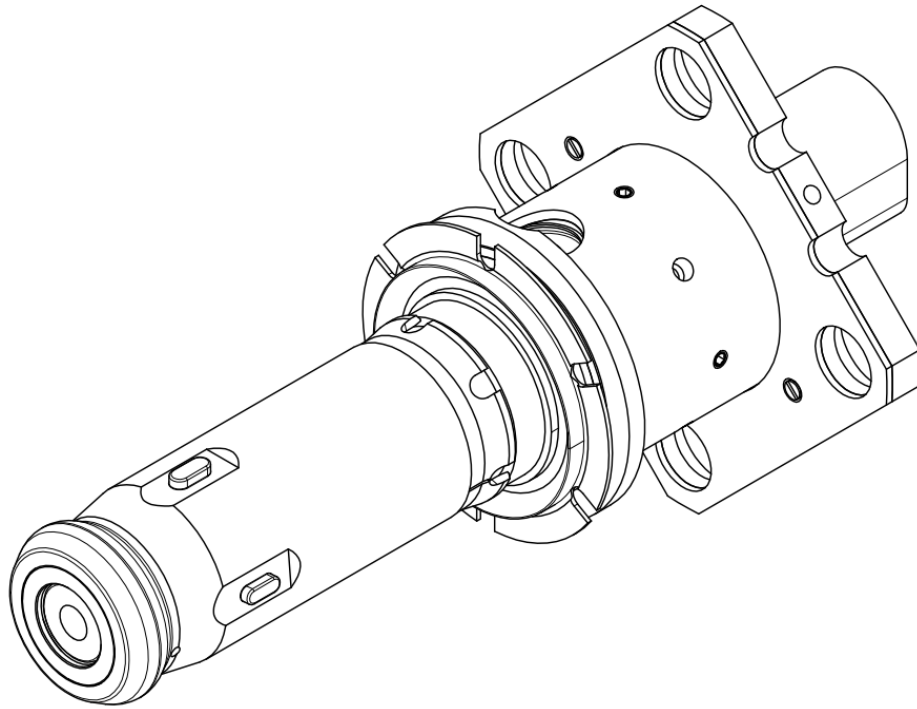
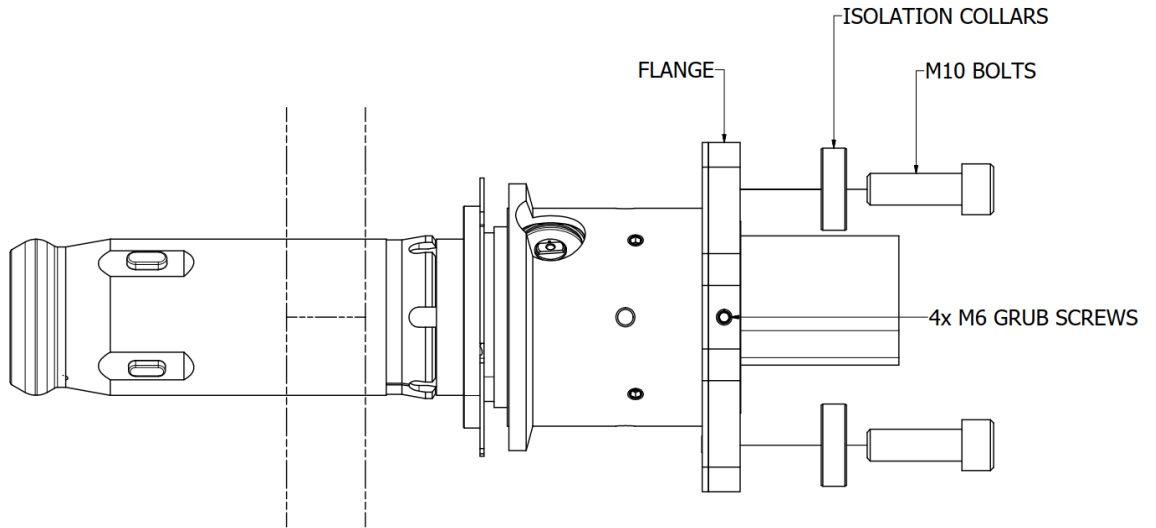

Figure 1

Image to show flange mounted connector.

**Flange Mount**

For stab plate connectors, there are 2 types of flange – Fixed and Compliant. 4x M6 grub screws are supplied for tightening the flange to the connector body. Apply Loctite 243, screw into the M6 tapped hole on the bottom face of the flange and tighten to 3.5 Nm. For stab plate connectors (metal to metal flange contact) mounting screws shall be torqued to 10-12Nm.



*Figure 2*

Fixed flanges utilise an M10 cap screw to secure the mounting flange. Compliant flanges use a spring mounting system to allow compliance in the positioning of the connector half. The compliant spring assemblies utilise the same flange as the fixed.

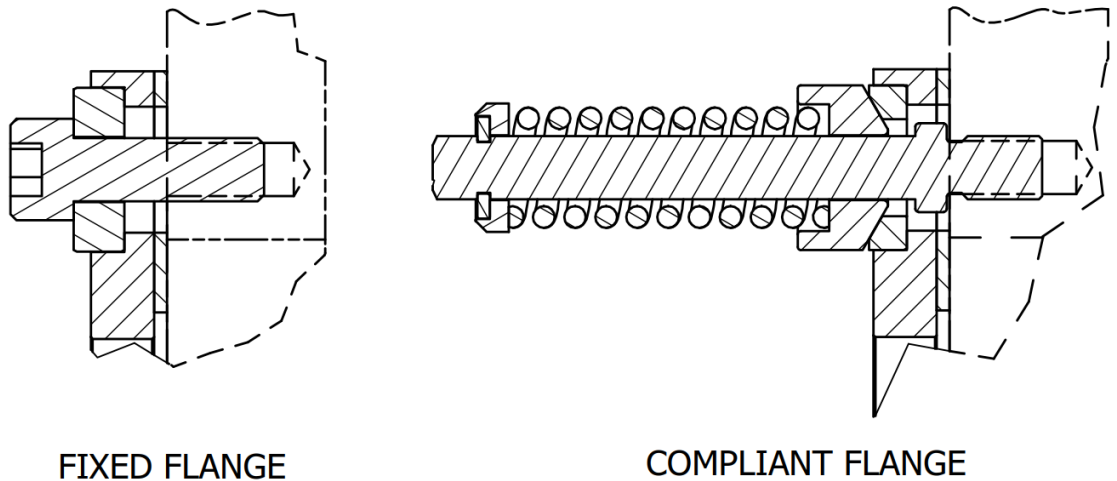

*Figure 3*

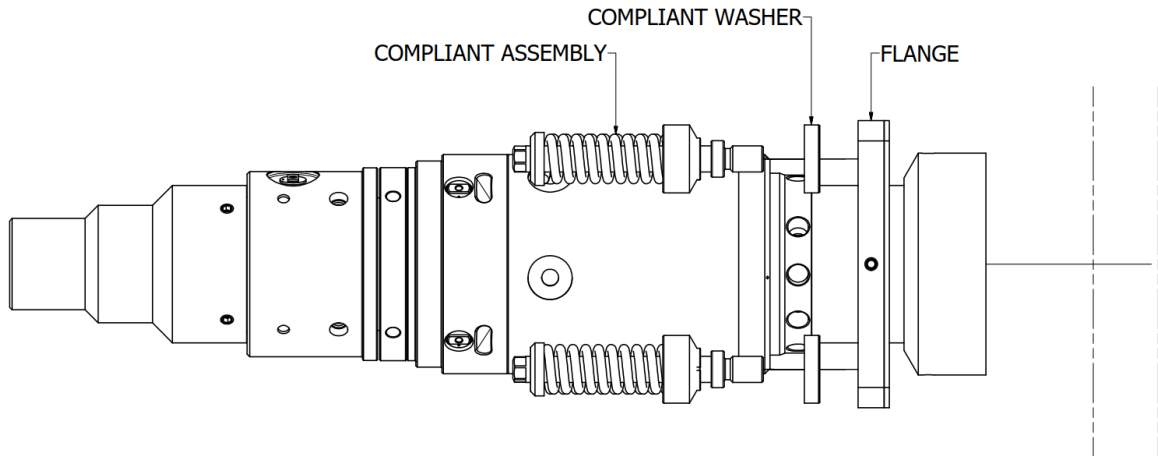

Figure 4

Apply a spot of Loctite 243 to the threads of the cap head screws.

- **Compliance**

One half of a stab mate connector pair must be allowed to float so that misalignment tolerances can be accommodated.

- **Misalignment tolerances:-**

Radial (mm) TBD  
 Angular (°) TBD  
 Rotational (°) TBD

- **Pre-Mating Checks**

Before mating, the receptacle connector should be checked for debris. The connectors have been designed to accommodate sand and silt contamination, however large pieces of debris should be removed. Use a water jet if subsea, see water jetting details in section 20.1.

- **Partial Disconnection**

Partial disconnection of optical connectors will result in an immediate loss of optical signal. The connector must be in its fully mated state in order for optical signal transmittance to occur. Partial disconnection will not effect the sealing of the connectors. Full connection can be established or re-established without performance loss.

- **Interrupted Connection**

Interrupted connection (i.e. Partial mate to full de-mate) can be carried out without any adverse affect to connectors.

- **Cathodic Protection:**

Super Duplex stainless steel (UNS S32550) connectors should be isolated from the CP system to reduce the slight possibility of hydrogen embrittlement.

- **Interface:**

DigiTRONf Bulkhead Interface: 10024652.

DigiTRONf Stab Receptacle Interface: 10011417

## 12. BULKHEAD CONNECTORS

- **Installation Sealed Bulkhead**

Note that DigiTRONf Bulkhead Connectors are for pressure compensated systems only.

Inspect 'O' ring grooves for damage and debris prior to installation of 'O' rings. Apply a small amount of DC4 grease to the interface 'O' rings and install on the connector, fit connector to interface ensuring correct orientation (unless otherwise stated ensure the primary key is at the 12-o'clock position).

Apply a spot of Loctite 243 to the threads of the cap head mounting screws and tighten to a torque of 10-12Nm for metal to metal flange contact.

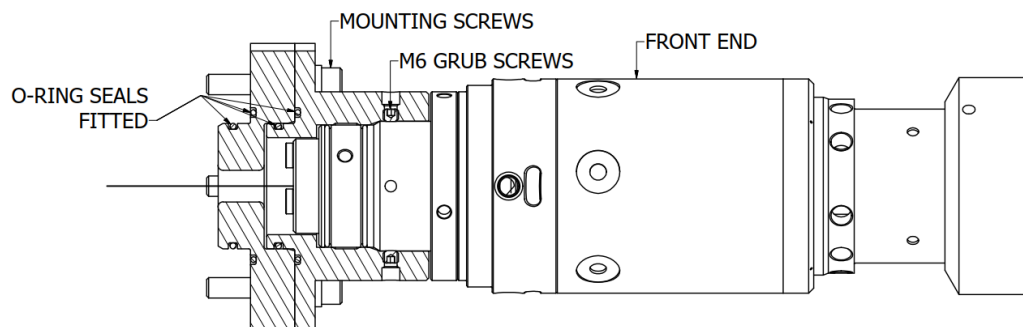

*Figure 5.*  
Sealed bulkhead receptacle connector

Bulkhead connectors with fibre pigtailed should be treated with care, particularly around the fibre exit point. Under no circumstances should the connector be lifted via the fibre. Fibre is vulnerable to damage and should remain in the provided tray until such time as it is to be terminated. Do not place any objects on to exposed fibre. Note that fibre damage may not be visible -damage to the core can occur without external damage. Ensure the fibre is not brought below its minimum bend radius (30mm). Ensure that once installed, ribbon fibre is not obstructed or snagged.

- **Misalignment tolerances:-**

Radial (mm)	+/- 20mm
Angular (°)	+/- 5°
Rotational (°)	+/- 12°

- **Pre-Mating Checks**

Before mating, the receptacle connector should be checked for debris. The connectors have been designed to accommodate sand and silt contamination, however large pieces of debris should be removed. Use a water jet if subsea, see water jetting details in section 20.1.

- **Partial Disconnection**

Partical disconnection of optical connectors will result in an immediate loss of optical signal. The connector must be in its fully mated state in order for optical signal transmittance to occur. Partial disconnection will not effect the sealing of the connectors. Full connection can be established or re-established without performance loss.

- **Interrupted Connection**

Interrupted connection (i.e. Partial mate to full de-mate) can be carried out without any adverse affect to connectors.

- **Cathodic Protection:**

Super Duplex stainless steel (UNS S32550) connectors should be isolated from the CP system to reduce the slight possibility of hydrogen embrittlement.

- **Interface:**

DigiTRONf Bulkhead Interface: 10024652.



### 13. ROV CONNECTORS, FLANGE MOUNT

View to show ROV compliant mount receptacle

NOTE ALIGNMENT  
DISC AND SCREW

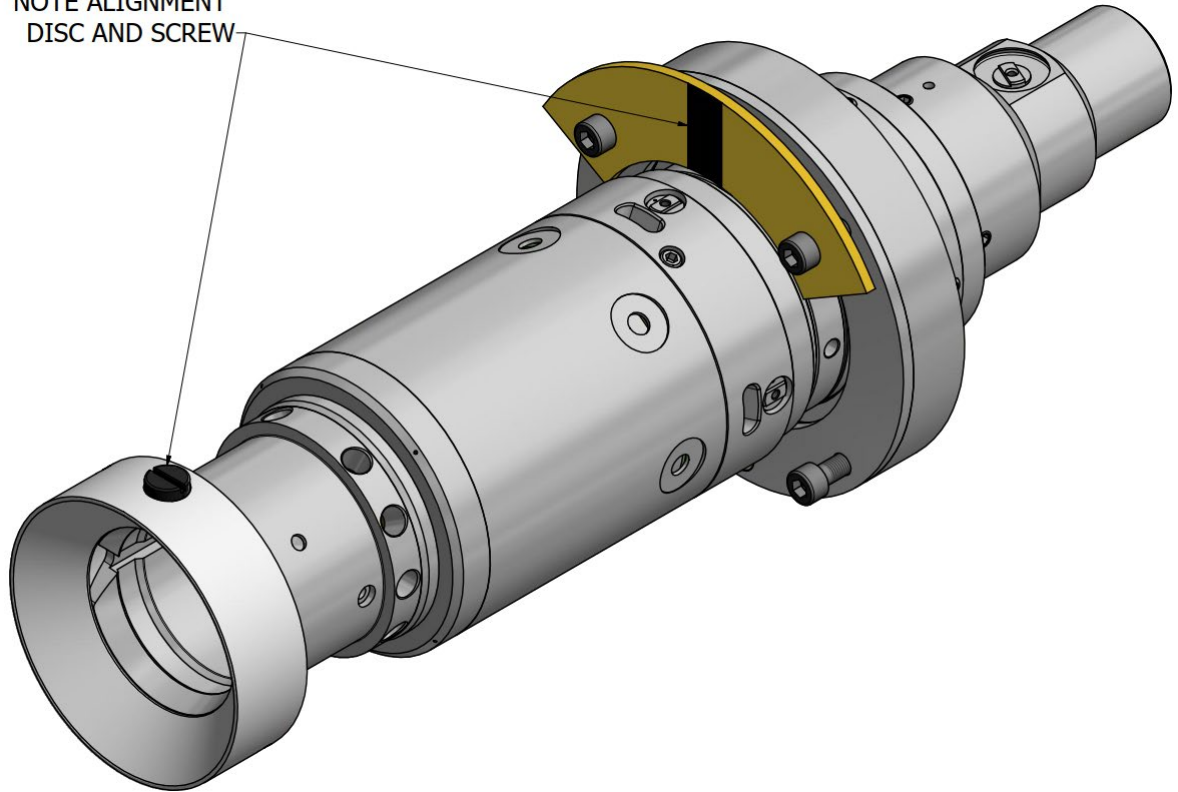

*Figures 6*

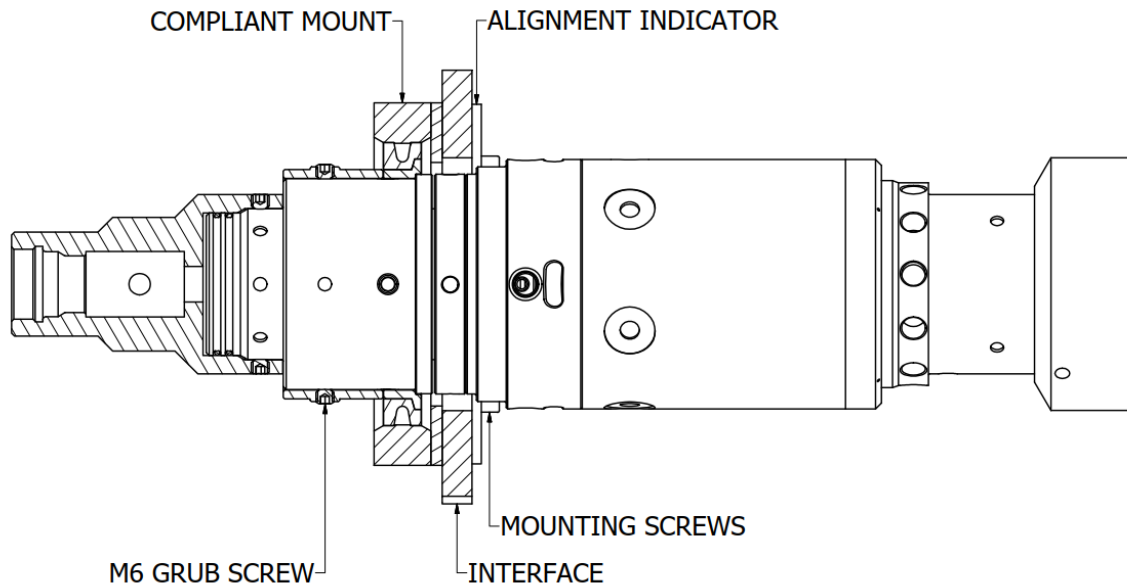
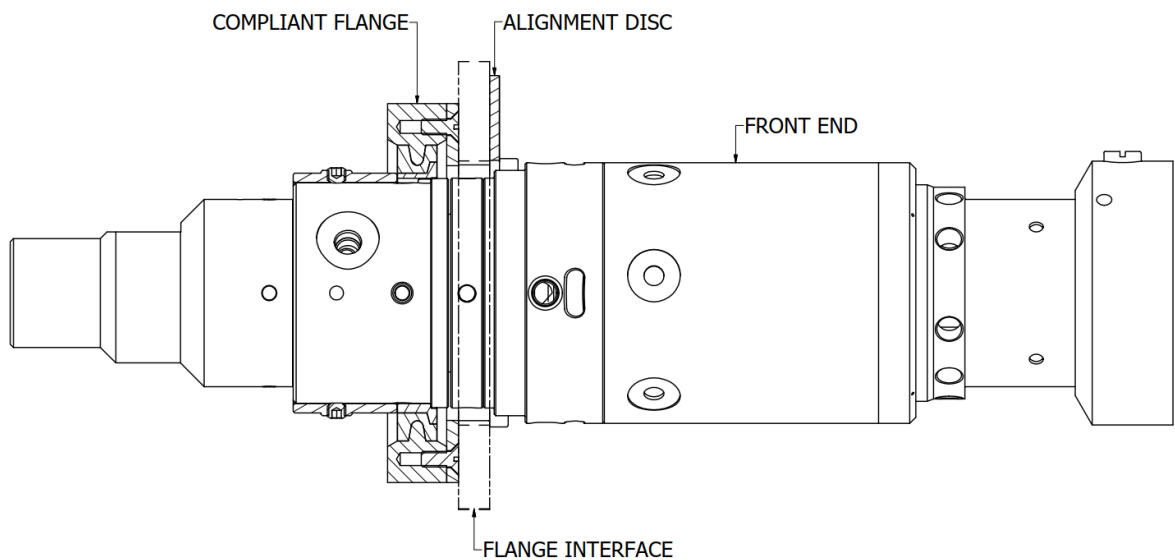

*Figure 7.*

Image shows section view to identify installation and parts

**Installation**

Apply a spot of Loctite 243 to the threads of the M6 cap head mounting screws and tighten to a torque of 7 Nm.



*Figure 8.*

Section view to show installation and parts of compliantly flange mounted connector

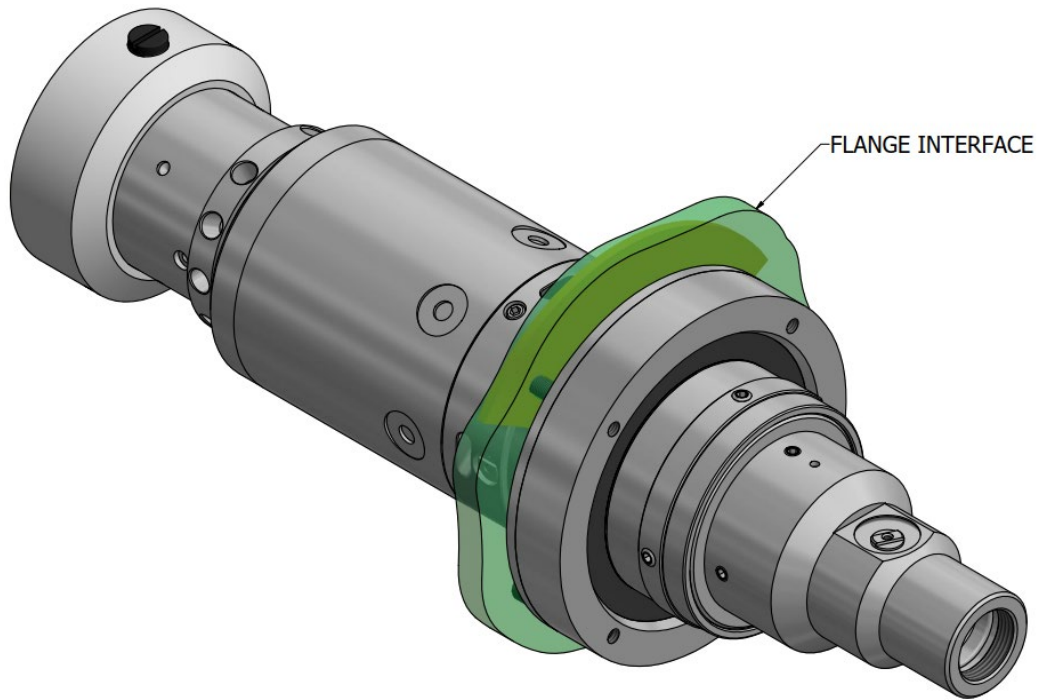

*Figure 9.*  
Image shows compliantly mounted ROV Receptacle

## 14. INSTALLATION OF FLYING ROV CONNECTORS

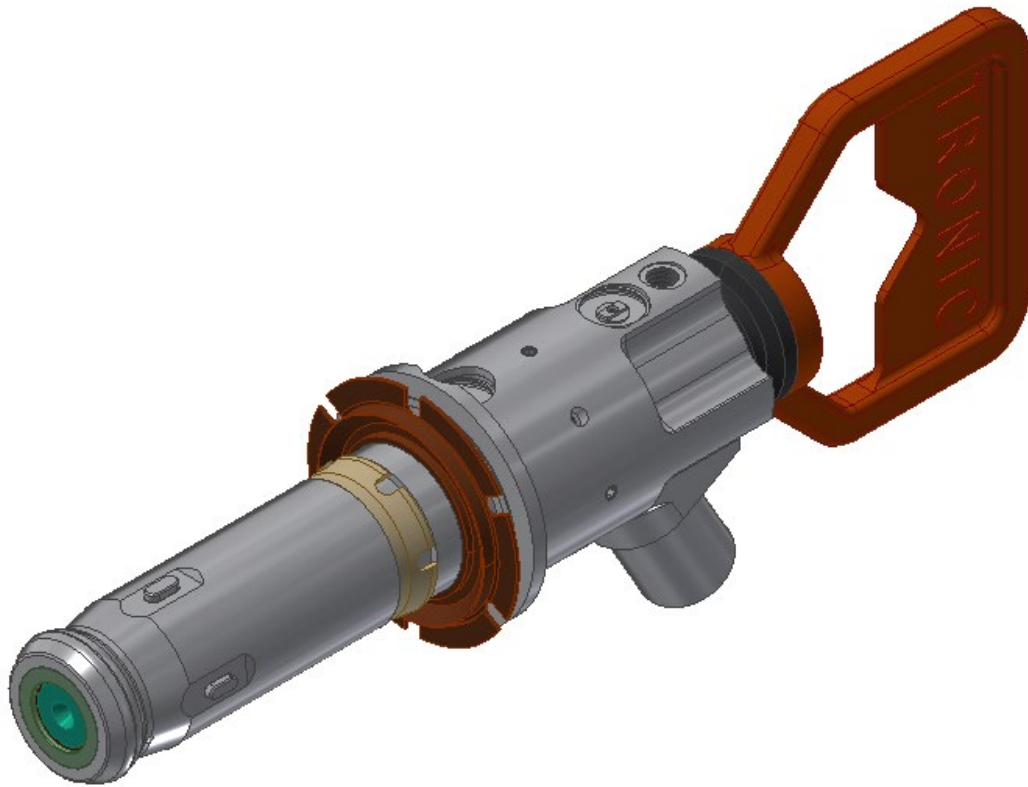

*Figure 10.*  
 Image to show Flying ROV Plug

### 14.1 ALLIGNMENT AND MATING

- DigiTRONf connectors have been designed to self align during mating.
- The connectors must be roughly aligned using the alignment marks on the plug body, flange and receptacle cone.
- The mounting of the ROV handle has sufficient compliance to accommodate fine adjustments during the final approach prior to connector engagement.
- Ensure correct orientation of the alignment disc
- It is important that the ROV compliant flange is orientated correctly.
- Observe the alignment marks on the flange, and orientate accordingly.
- Please see images on pages 19 & 20 (figure 11).

## IMAGES OF ALIGNMENT MARKS AND LIP SEAL MATING INDICATOR

### Top View

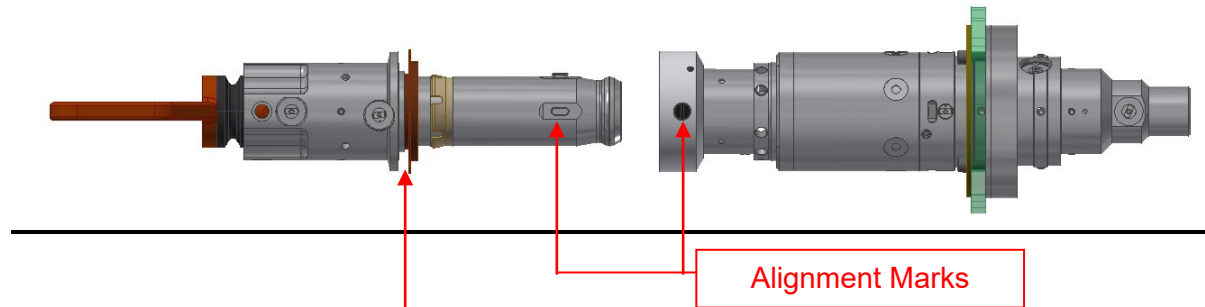

### Side View

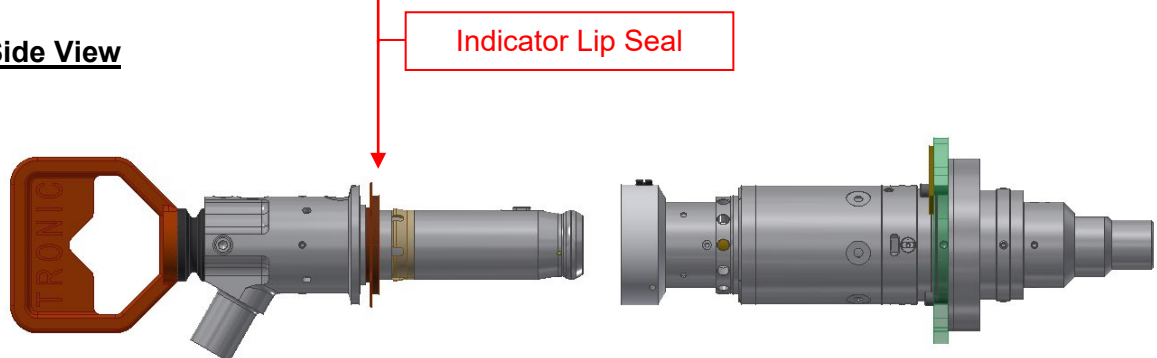

### Fully Mated – Lip seal not visible

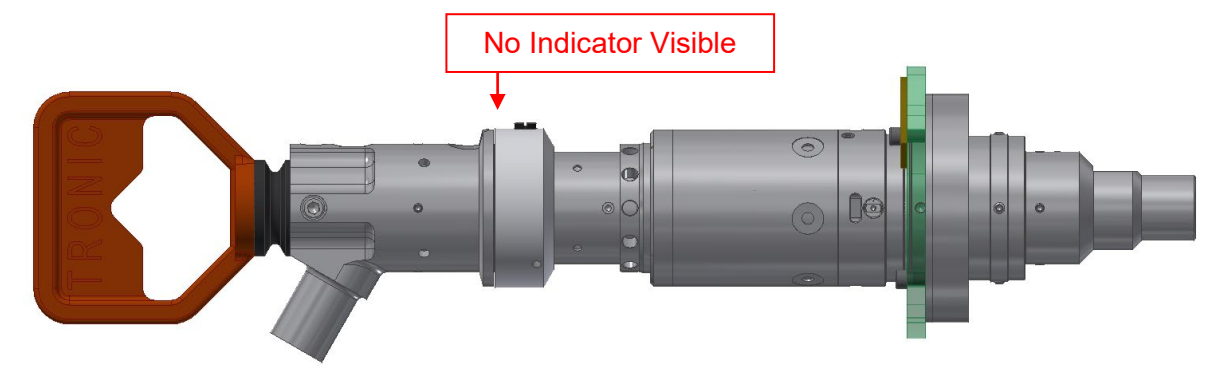

Figure 11. Images of alignment marks and Indicator Lip Seal

- **Mate/De-Mate Speed**

The connectors have been designed to operate across a wide range of mate / de-mate speeds. There is no practical limit to the speed at which the connectors may be mated or de-mated, however as a guide mating/de-mating speed should not exceed 0.5m/s

- When fully mated, lip seal will not be visible and connection should look like as shown above (figure 11).
- If lip seal can still be seen remove and retry making connection by following the procedure again.
- If connectors can't be mated both the plug and receptacle need to be inspected for any misalignment damage or debris that is preventing connection.
- If any damage has occurred please record on 'Information and notes/health and safety feedback' at the rear of this document and inform Technical Department.

## 15. DUMMY / PARKING CONNECTORS

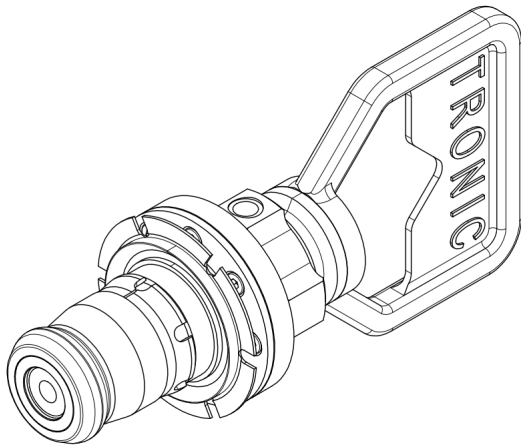

*Figure 12.*  
ROV Dummy Plug

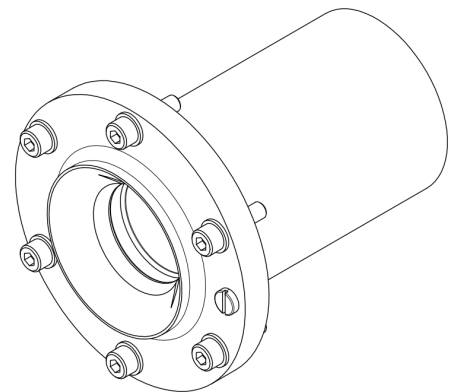
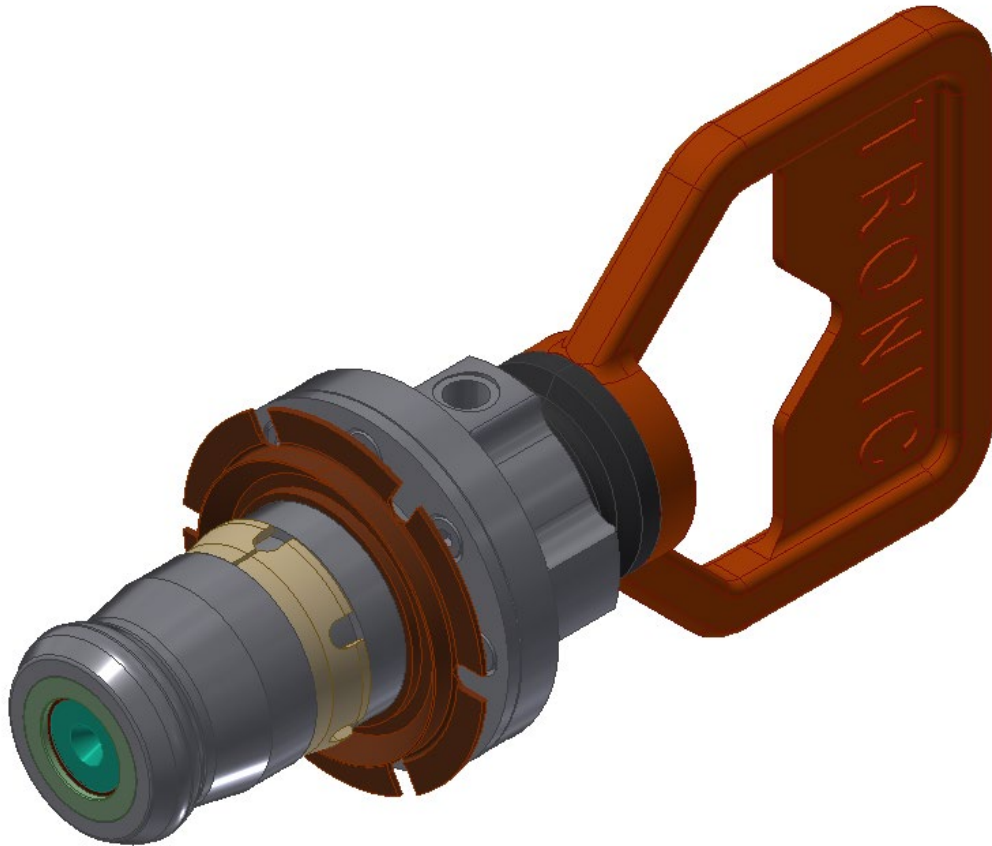

*Figure 13.*  
Stab Flange mounted receptacle

**Installation of Flange mounted dummy connectors is the same procedure as none dummy connectors, so please follow the installation instructions in the relevant sections.**

**Section 12 –Bulkhead connectors**  
**Section 13 – ROV connectors Flange mount**

## 16. INSTALLATION OF FLYING ROV DUMMY CONNECTORS



*Figure 14.*  
Image to show Flying ROV dummy

### 16.1 ALLIGNMENT AND MATING

- DigiTRONf connectors have been designed to self align during mating –in the case of the Flying ROV Dummy however, no alignment is necessary.
- The mounting of the ROV handle has sufficient compliance to accommodate fine adjustments during the final approach prior to connector engagement.



## 16.2 MECHANICAL FORCES DURING MATING / DE-MATING

The connectors have been designed to accommodate over stroking and bending forces to the following limits.

Over-stroking force < 5000N

Bending < 5000N

- The maximum bending moment that can be applied to the connectors when mated is 2000Nm before the risk of mechanical damage to the optical connection becomes significant.

## 16.3 MAXIMUM MISALIGNMENT VALUES

The values for maximum misalignment that the DigiTRONf connectors can tolerate with mating still possible are as follows.

Misalignment Type	
Rotational (0°)*	±12°
Radial	±20mm
Angular	±5°

\*Note: Dummy Plug is not rotationally dependant

## 16.4 POST MATING CHECKS (DIGITRONF ROV ONLY):

During mating the orange Indicator Lip Seal located on the plug connector will fold back and disappear into the alignment cone on the receptacle connector. After a successful mating of the connectors no part of the indicator lip seal should protrude through the joint between the plug and receptacle connectors.

## 16.5 ROV MATING / DE-MATING FORCES (DIGITRONF)

Maximum Mate/De-Mate force: <800N

## 16.6 DE-MATING

- De-mating is achieved by a straight pull on the ROV handle sufficient to release the latching mechanism.
- Force required is detailed under the mechanical forces section see section 16.5
- Ensure protective caps are fitted when not mated and while in storage
- If the connectors are to be left unmated, in seawater, for any length of time dummy connectors must be used to protect the sealing faces in the receptacle connectors. Over exposure will increase the risk marine growth on the sealing surfaces of the receptacle. This could lead to damage to the seals. Plug connectors do not require full dummy connectors for protection. Siemens advise the fitting of acetal caps to protect plugs.
- For topside use, e.g. SIT, there is a mate/de-mate tool available. Part number 10069863.

## 17. TEST CONNECTORS

Test Plug and Receptacles are available. Test connectors utilise E2000 bulkhead connectors to allow access to individual lines.

### 17.1 TESTING OF SINGLE CONNECTORS

- The appropriate test connector must always be used to make optical contact during testing.
- **UNDER NO CIRCUMSTANCES** should a foreign object (such as a screwdriver, test probe, or crocodile clip) be used to activate connector mechanisms.
- Such actions will invalidate the warranty of the connector.
- Guide pins must never be removed from test connectors as this can lead to damage and will invalidate the connector warranty.
- To perform any testing refer to specific project documentation for details of procedures.

**NOTE: No part of the connectors should be dismantled prior to or during deployment, apart from the removal of protective caps, since there are no user serviceable parts inside.**

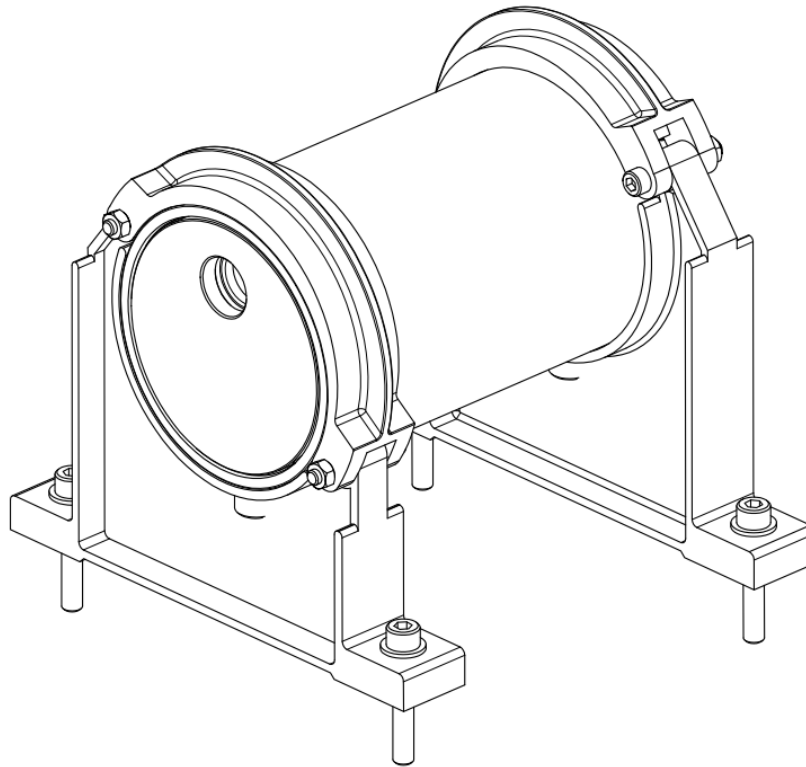
**18. FIBRE MARSHALLING UNIT**

*Fig 15  
Fibre marshalling unit*

A Fibre Marshalling Unit (FMU) is generally required when a harness utilises a configured splice arrangement (i.e. not a direct 1 to 1 type). The FMU allows for full configuration of the splice arrangement and up to 4 ports (input or output) per side.

**Installation**

If not already fitted, secure the 2 mounting brackets to the FMU assembly. Ensure the alignment holes in the FMU align with the dowels in the bracket. Secure the FMU to the mounting plate using 4 off Bolts and Washers (supplied).

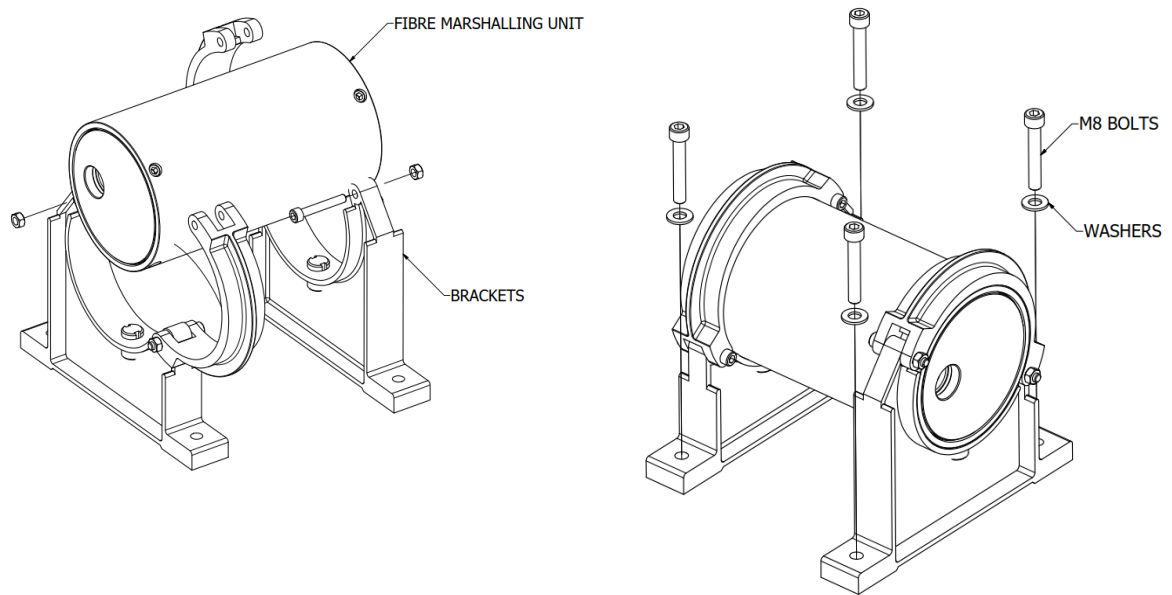

Figure 16

## 19. DIGITRONF CONNECTOR SPECIFICATION

### Optical and Mechanical

Optical Specification	
Number of Ways	12
Insertion Loss	Typically <0.2dB, Max 0.4dB
Back Reflection	Typically <-55dB, Max -45dB
Maximum Optical Crosstalk	<-60dB

- Working pressure: 5800 psi (13123 ft / 4000 metres water depth)
- Working temperature range: -5 to +50°C
- Onshore testing temperature range: -20°C to +50°C
- Storage temperature range: -40 to +70°C

Please note; maximum storage temperature takes into account solar gain. Surface temperature must not exceed 70°C. Suitable protection must be used to ensure maximum storage temperature is not exceeded.

## 20. MAINTENANCE

### 20.1 MARINE GROWTH AND CALCAREOUS DEPOSITS

To remove calcite growth from Siemens connectors, a solution of 50% Citric Acid is recommended. All Seawater exposed elastomeric materials in Siemens connectors have been fully tested against 50% Citric Acid and are compatible for duration of 1 hour. In addition, the thermoplastic materials have good resistance to Citric Acid.

Other acid cleaners, such as 50% Acetic Acid, should **not be** used as they may cause deterioration of the elastomeric materials. Chiseling and abrasive methods are not recommended. Use of a water jet is acceptable, but the jet should not be directed onto the shuttle pins at the front of the plug, or the front face of the receptacle, as this could result in a risk of water being forced through the primary seals.

Water jetting is permitted subsea (not in air) providing water jet is not directed at end faces of connectors (see below).

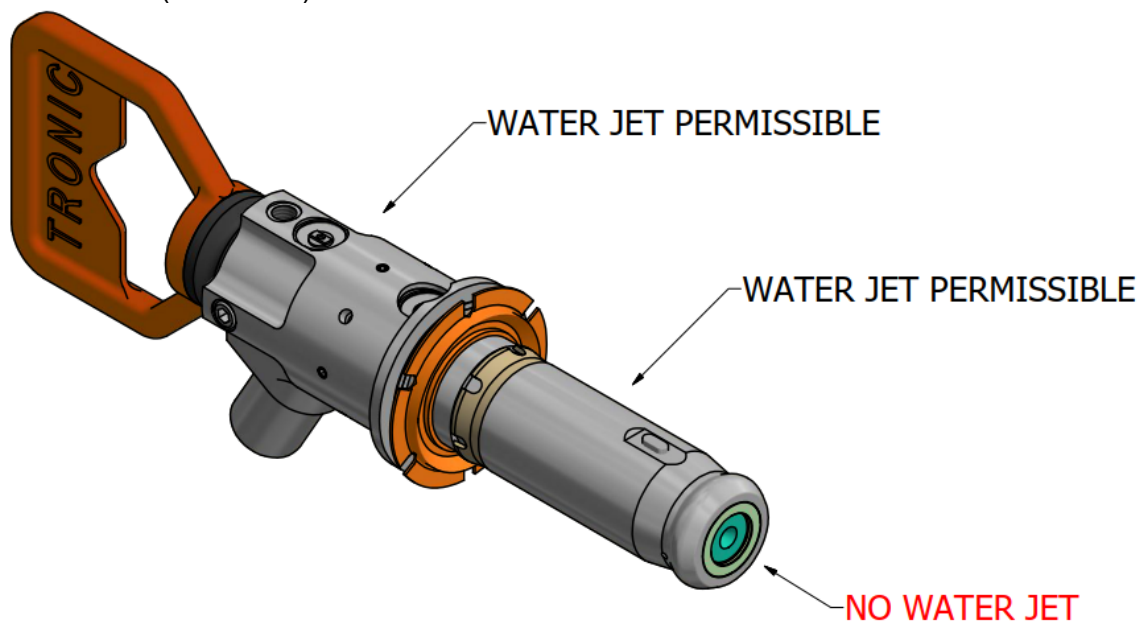

Figure 17 –Plug permissible Water Jetting

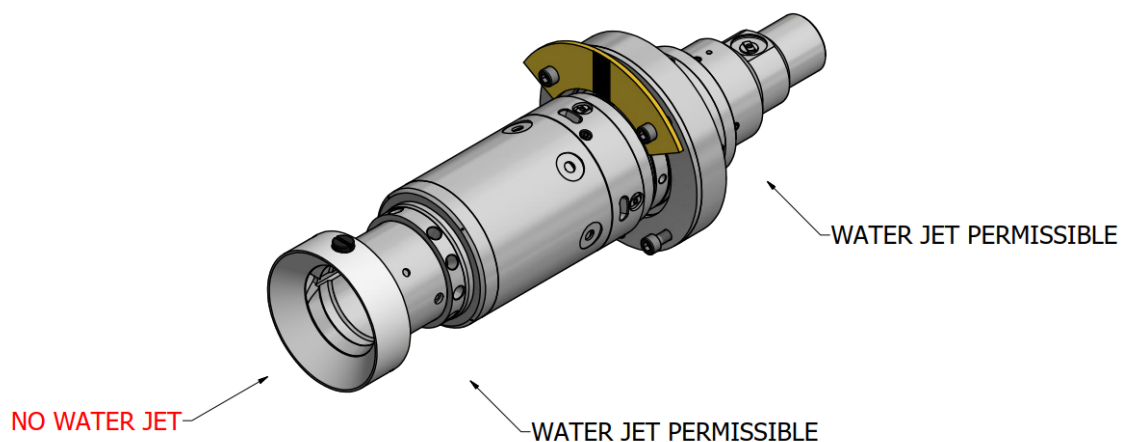

Figure 18 –Receptacle Permissible Water Jetting

**Any damage found should be recorded and reported to the Technical Department.**

