

contents

Fast Bus busbar adapter system

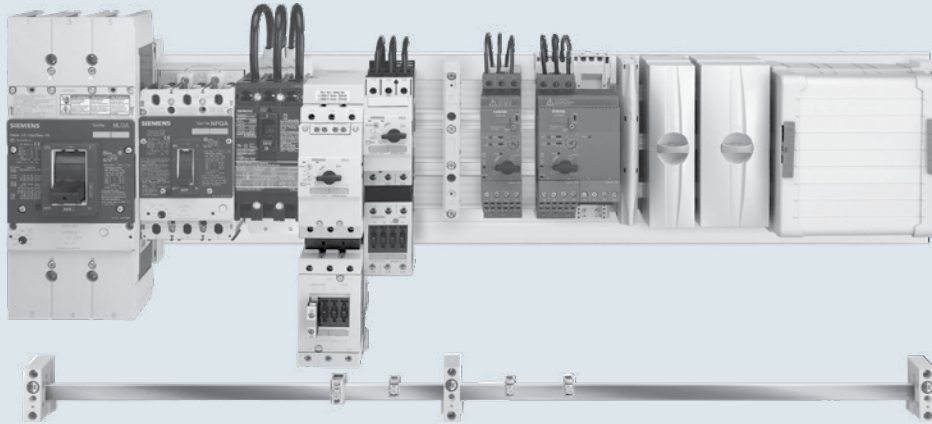

60 mm system

Page

Selection and ordering data

- | | |
|-----------------------------|------|
| • Busbar holders | 5/9 |
| • Fast Bus adapter shoes | 5/11 |
| • Incoming supply terminals | 5/6 |
| • Copper busbar | 5/6 |
| • Busbar covers | 5/6 |
| • Other accessories | 5/6 |

- | | |
|--------------------|-----------|
| Overview | 5/2 |
| Introduction | 5/3 |
| Technical Data | 5/3 |
| Dimension drawings | 5/10-5/15 |

FBCB Fast Bus circuit breakers

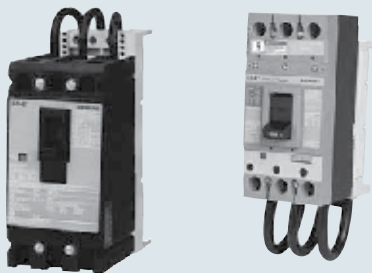

FBCB Fast Bus main and feeder circuit breakers

Page

Selection and ordering data **UPDATED**

- | | |
|---|-----|
| • Fast Bus circuit breakers assemblies and kits | 5/7 |
| • Fast Bus adapter shoes for VL breakers | 5/8 |

Fast Bus combination starters

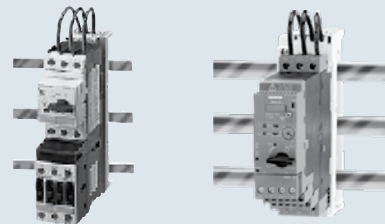

3RA2 Fast Bus combinations starters 3RA6 Fast Bus compact starters

Selection and ordering data

- See Section 4

Busbar adapter systems

Busbar adapter systems
with busbar centerline spacing of 60 mm

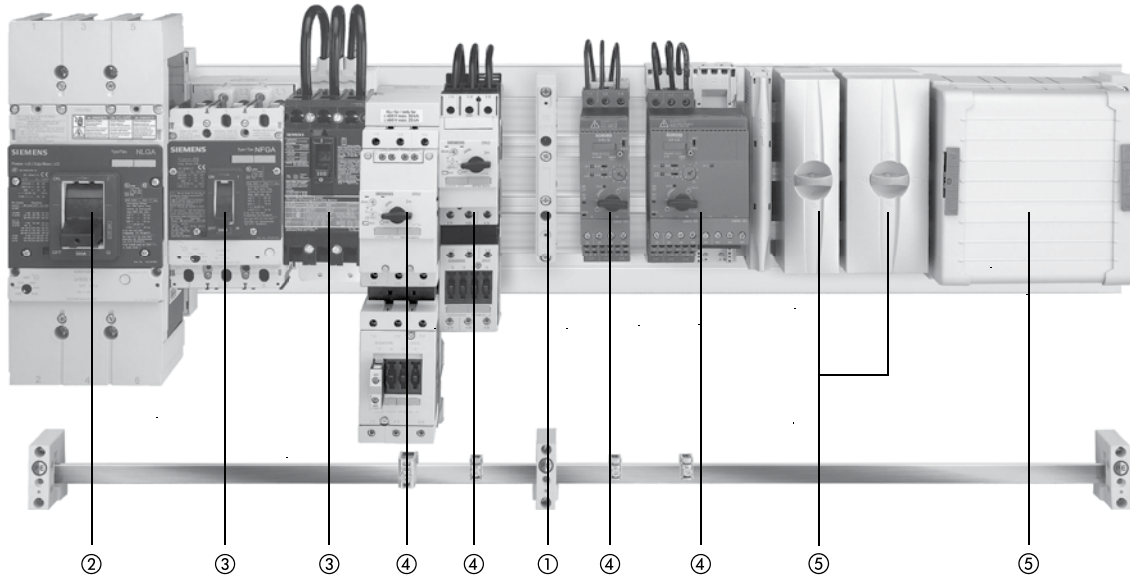

60 mm busbar system

for sharp-edged copper busbars
to DIN 46 433,
width 20 mm to 30 mm,
thickness 5 mm and 10 mm

	Page
① Busbar holder End and intermediate holders for flat copper profiles	5/6
② Fast Bus main circuit breakers from 15 to 500A	5/6
③ Fast Bus circuit breakers from 15 to 500A	5/7

	Page
④ 3RA2 Combination Starters	see section 4
⑤ Incoming supply terminals	5/6

Fast Bus Busbar Adapter System

Introduction

General

The Fast Bus Multi-Motor Control system is a 3-phase insulated busbar system and is ideal for space saving in panel designs. The system saves considerable line side wiring and space for multi-motor panels. It is also ideal for panels where several feeder breakers are used and will save significant wiring space and wiring labor. The system is also ideal for future expansion planning, when building control panels. SIRIUS 3RV/3RT starter combinations and Siemens circuit breakers are all adaptable to Fast Bus for convenient mounting and faster replacement times.

Fast Bus is ideal for industrial applications where system availability is important.

How to Select Fast Bus

- 1) Determine the required load.
- 2) Select method to power Fastbus.
 - Main lug up to 800A using a single set of lugs or up to 1400A using a double set of lugs.
 - Circuit breakers, 15A to 500A

If load exceeds 500A, the CB must be separately panel mounted and fed to a main lug infeed module.
- 3) Select 3RV MSP & 3RT contactor components and appropriate adapter shoe or select preassembled 3RA starters. See section 4.
- 4) Select appropriate length busbar, busbar holders, insulation covers and any other required components.

Features

- Simple economical installation
- Compact design
- Requires fewer mounting holes
- Domestic and International approvals
- Touch safe
- Modular design
- Provision for system expansion
- Clip-on shoes provide mechanical and electrical connections to panel mounted busbars
- Main and Feeder breakers mount to busbars

Benefits

- Saves installation time
- Reduces space requirements
- Minimizes layout time
- Allows flexibility for domestic and export business
- Protection for maintenance personnel
- Improves equipment mounting density
- Reduces time and costs associated with system expansion
- Reduces mounting and wiring time and provides trouble free connections
- Allows for quick retrofitting of breakers

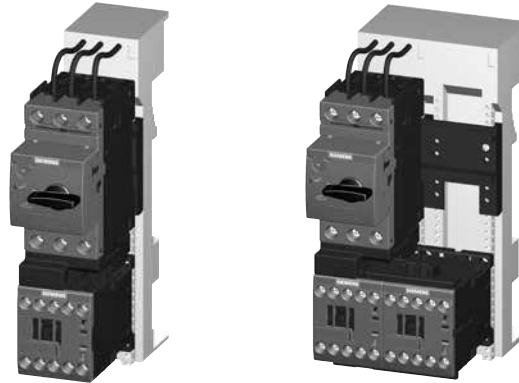

General Ratings of Fastbus System

	IEC	Domestic
Rated operating voltage	690V	600V
Rated insulation voltage, IEC VDE	AC 1000V	N/A
Temperature stability	Up to 105 degrees C	N/A
Busbar support and adapter shoe material	Glass-reinforced polyamide	Same
Color	RAL 7035, light gray	Same

Ampacity

Busbar thickness and width		
5 x 20 mm	3/16" x 3/4"	362A
5 x 25 mm	3/16" x 1"	432A
5 x 30 mm	3/16" x 1 1/8"	500A
10 x 20 mm	3/8" x 3/4"	564A
10 x 25 mm	3/8" x 1"	660A
10 x 30 mm	3/8" x 1 1/8"	756A
720mm ²	---	1400A

For technical information on E and F frame circuit breakers used as main and feeder breakers, see section 17

Thermal busbar currents, E-Cu, bare, at 35 °C ambient temperature in accordance with DIN 43 6711

Busbar dimensions	System mm	Thermal current at Busbar temperature		
		65 °C A	85 °C A	105 °C A
20 x 5	60	274	362	430
25 x 5	60	327	432	513
30 x 5	60	379	500	595
20 x 10	60	427	564	670
30 x 10	60	573	756	900



Fast Bus set-up

The Fast Bus system is designed to be easy to use and to save set up time.

8US Busbar holders

The 8US busbar holders are designed to accommodate ampacities up to 1400A. In some cases, the busbar holder will accept busbars in either 5mm or 10mm widths. Refer to page 5/6 for selection details.

High quality material

Busbar supports and fuse bases are manufactured from glass-fiber reinforced, thermoplastic polyester with the color RAL 7035, light gray. The material ensures excellent mechanical, chemical and electrical properties. Furthermore, the material has an extremely low flammability and meets the requirements of UL 94 V0.

8WC Busbar and busbar systems

The most common size busbar for applications in the US is the 8WC5053 (20 mm x 5 mm), however there are other styles available depending on your application.

Busbar systems with 60 mm busbar center-to-center clearance have now become firmly established in the US market.

The permissible busbar temperature is a decisive factor when dimensioning the busbars. The busbar temperature is dependent on the current, the current distribution, the busbar cross-section, the busbar surface, the position of the busbar, the convection and the ambient temperature. The values stated in the table on page 5/3 can only be considered as reference values because the conditions vary with each location. The values are based on constant current over the whole busbar length.

The trend toward busbars proves most advantageous when the incoming supply is centrally located and the load is distributed symmetrically on both sides.

For the assemblies of a busbar system in the feeder circuit the UL directives specify components with large clearance in air and creepage distances (see the table below). Components of the 8US1 busbar system which meet this requirement can be found in this chapter.

Note:

The design of an 8US1 busbar system for use in the feeder circuit always presumes the use of the UL base plate (8US19 22-2UA01) so that the clearance in air and creepage distance requirements are met.

Feeder/branch circuit according to UL 508A

The feeder circuit is that part of a circuit which comes in front of the last short circuit protection device (SCPD). The branch circuit is that part of the circuit which follows after the last short circuit protection device. When the 8US1 busbar system is used in a switchgear which must comply with UL directives, it is important to establish whether it is to be used in the feeder circuit or the branch circuit. Components used in the feeder circuit require larger clearance in air and creepage distances than in the branch circuit.

Simple Fast Bus system

The two illustrations above show the very basic items needed when setting up a Fastbus system.

- ① 8US1 Busbar holder (5/6)
- ② 8US1 Ground busbar support (shown attached however can be mounted separately 5/6)
- ③ Ground busbar available in 5 x 20 mm to 10 x 30 mm
- ④ 8WC Busbar (8WC5053 shown) FBB36 Busbar (5/6)

Short-circuit strength

The short-circuit strength of the busbar system is dependent on the spacing of the busbar holders and on the busbar cross-section.

The short-circuit strength of the whole system is dependent on the short-circuit strength of the busbar system and the components that are mounted to the system.

Applications

The 8US Fast Bus distribution system is ideal for control panel builders with multiple motor applications. These applications are most common in the material handling, automotive, food processing, pharmaceutical and paper processing industries.

	Clearance in air	Creepage distance
Between live parts	25.4 mm (1 inch)	50.8 mm (2 inch)
Between live parts and grounded, non-insulated metal parts	25.4 mm (1 inch)	25.4 mm (1 inch)

Fast Bus Busbar Adapter System

Introduction

Fast Bus combination starters and group installation assemblies

Ratings for Group Installations per NEC 430-53

Group Installation is an approach to building multiple motor control systems in accordance with Section 430-53 of the National Electrical Code. In Group installation, multiple motor starters can be grouped under one short circuit protective device. The 3RV MSPs have been UL listed for use in Group Installations both with and without 3RT contactors when mounted on the Fast Bus system. A 3RT contactor is added when remote operation of the motor is required.

Standard Installation, NEC 430-52

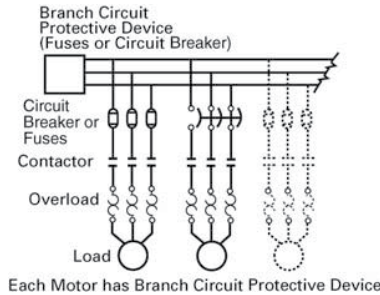

Group Installation, NEC 430-53

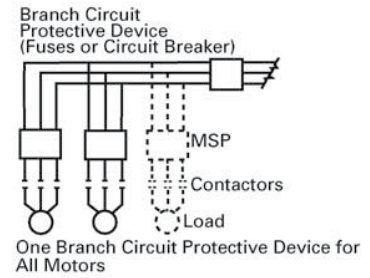

MSP Type	FLA Amp Range	FLA Amp Range	Maximum rating of Group Branch Circuit Protective Device		Short Circuit Current Ratings ^{1) 2)}		
			Fuse	Circuit Breaker	240V	480V	600V
3RV201	S00	0.11-12.5	The main fuse should be selected based on the FUSE selection procedure listed below.	The main CB should be selected based on the CIRCUIT BREAKER selection procedure listed below.	65kA	—	30kA
3RV201	S00	0.11-16			65kA	65kA	—
3RV202	S0	3.5-12.5			65kA	—	30kA
3RV202	S0	3.5-25			65kA	65kA	—
3RV202	S0	28-32			65kA	50kA	—
3RV202	S0	36-40			65kA	12kA	—
3RV203	S2	11-50			65kA	65kA	25kA
3RV204	S3	28-100			65kA	65kA	30kA

The selection of components for Group Installation is a simple process of the following three steps:

1. Selection of the Branch Circuit Protective Device, fuse or circuit breaker.
2. Selection of the 3RA Motor Starter based on the motor Full Load Amps.

Circuit Breaker Selection

Select a circuit breaker (CB) between:
 Minimum CB size (per NEC430-110):
 Sum of all motor FLC (per NEC table 430-150) x 115%.
 Maximum CB size (per NEC430-53c):
 250% x FLC of the largest motor + FLC of all other motors.

Fuse Selection

Calculate the maximum fuse size per NEC430-53c.
 Max Fuse Size = 175% x FLC of largest motor + FLC of all other motors (FLC's from NEC table 430-150).

Assembled Starter Type	Starter Frame Size	FLA Amp Range	Short Circuit Current Ratings (Type E) ¹⁾		
			240V	480Y/277V	600Y/347V
3RA201	S00	0.11-12.5	—	—	30kA
3RA201	S00	0.11-16	65kA	65kA	—
3RA202	S0	0.45-12.5	—	—	30kA
3RA202	S0	0.45-25	65kA	65kA	—
3RA202	S0	28-32	50kA	50kA	—
3RA203	S2	11-50	65kA	65kA	25kA
3RA204	S3	28-75	—	—	30kA
3RA204	S3	28-100	65kA	65kA	—

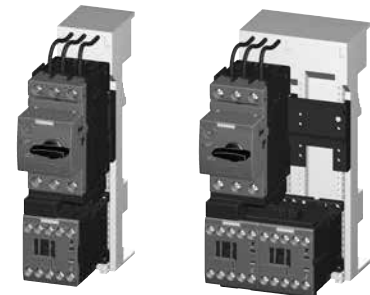

¹⁾ Branch Circuit Protective Device for 480V-Ratings: The appropriate BCPD need to be determined in accordance with the National Electrical Code, Article 430-53 and the application. The following devices are permitted:

Fuses: Classes RK1, RK5, J, G, T, CC or Circuit breakers: Listed Siemens type, with a marked short-circuit rating equal or larger than the available short-circuit current rating. These devices were tested for group installation use at the above levels without any upstream branch circuit device.

²⁾ 3RA2 used as Manual Motor Controller; Branch Circuit Protective Device for 600V-Ratings: Max. Class J 50A

³⁾ Starter sizes S00,S0 and S3 require additional type E line side terminal adaptors on the MSP for type F applications. See section 1 accessories

Fast Bus Busbar Adapter System

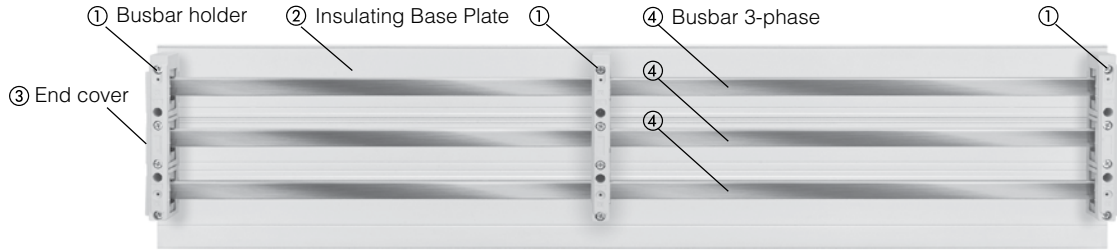

60 mm system

Selection and ordering data

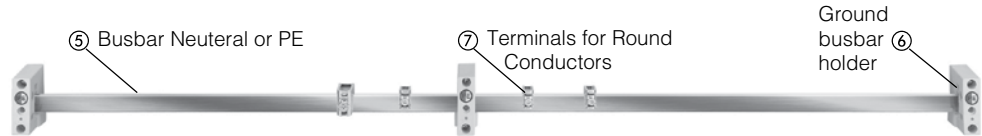

- ① Busbar holder
- ② Insulating Base Plate
- ③ End cover
- ④ Busbar 3-phase
- ⑤ Busbar Neutral or PE
- ⑥ Ground busbar holder
- ⑦ Terminals for Round Conductors



	Description	UL Current rating	UL508A Compliance ¹⁾	Order No.	Pack Units
	Base plate ②				
8US1922-2UA01	3-pole system flat 230 mm x 1100 mm	—	required	8US19 22-2UA01	
	Copper Busbar with tin plating				
8WC5	20 mm x 5 mm x 914 mm (36") for 60 mm systems	362A	yes	FBB36	3 pcs
	20 mm x 5 mm x 1524 mm (60") for 60 mm systems	362A	yes	FBB60	3 pcs
	20 mm x 5 mm x 2000 mm (78.74") for 60 mm systems	362A	yes	8WC5053	
	25 mm x 5 mm x 2000 mm (78.74") for 60 mm systems ⁴⁾	432A	yes	8WC5054	
8US1948-2AA00	30 mm x 5 mm x 2000 mm (78.74") for 60 mm systems	500A	yes	8WC5055	
	20 mm x 10 mm x 2000 mm (78.74") for 60 mm systems	564A	yes	8WC5063	
	30 mm x 10 mm x 2000 mm (78.74") for 60 mm systems	756A	yes	8WC5065	
	720 mm ² x 2400 mm (94.49") Twin T (TT) Busbar	1400A	yes	8US19 48-2AA00	
	Busbar holder (end and intermediate) ①				
8US1922-1AC00	3-pole with inside mounting for 20 mm and 30 mm x 5 mm or 10 mm	—	yes	8US19 23-3UA01	
	3-pole with inside mounting for 25 mm x 5 mm or x 10 mm	—	—	8US19 23-3AA00	
8US1923-3UA01	3-pole with inside mounting for Twin T (TT) w/ end cover	—	yes	8US19 43-3AA01	
	Busbar holder end cover ③				
	3-pole end cover fits 8US19 23-3UA01 and 8US1923-3AA01		required	8US19 22-1AC00	
	Ground Busbar holder ⑥				
8US1923-1AA01	1-pole with inside mounting for 20 mm - 30 mm x 5 mm or 10 mm ²⁾		n/a	8US19 23-1AA01	
	Cover profiles for Busbars				
	for 5 mm busbars up to 30 mm wide 1000 mm length	—	required	8US19 22-2AA00	
	for 10 mm busbars up to 30 mm 1000 mm length	—	required	8US19 22-2BA00	
8US1922-2AA00	for Twin T (TT) busbar 1000 mm length	—	required	8US19 22-2DA00	
	Reserve Space Cover (for covering round terminals placed on 3-phase busbar)				
	Holder for reserve space cover 32mm height	—	required	8US1922-2EA00	4 pcs
	Holder for reserve space cover 107 mm length	—	required	8US1922-2EA01	8 pcs
	Reserve space cover 195mm height / 700mm length	—	required	8US1922-2EB00	
8US1922-2EB00					
	Feeder Lugs (mounts to all busbar sizes on this page)				
	3-pole terminal plate with cover 20 mm x 200 mm 16-4 AWG	80A	yes	5SH3538	
	3-pole terminal plate with cover 54 mm x 200 mm 10-2/0 AWG	175A	yes	8US19 21-1BA00	
	3-pole terminal plate with cover 81 mm x 200 mm 2 AWG-250 MCM	440A	yes	8US19 21-1AA00	
	3-pole terminal plate with cover 180 mm x 200 mm 250-600 MCM	560A	yes	FBT600F	
5SH3538	3-pole terminal plate 154 mm x 184 mm 300-600 MCM	560A	yes	8US19 41-2AA03	
8US1921-1BA00	3-pole terminal plate 160 mm x 184 mm for flat bars up to 32 mm x 20 mm	800A	yes	8US19 41-2AA04	
	Cover for 8US19 41-2AA03 and 04 180 mm x 200 mm x 90 mm	—	yes	8US19 22-1GC00	
FBT600F w/cover					

1) UL 508A labeled panels require the use of components that meet the creepage and air distances of 1" air clearance and 2" creepage distance. N/A = not applicable for given item.
2) Current rating dependent on size of busbar used. Refer to busbar selection data.

Fast Bus Busbar Adapter System

60 mm system – Circuit breaker assemblies and kits **UPDATED**

Selection and ordering data

Description

FBCB Fast Bus circuit breakers

Offer a full range of feeder circuit breakers from 15A to 500A. All Sentron kits 125A and under are pre-assembled on 60 mm Fast Bus adaptor shoes and ready to place on the busbar. All other circuit breaker kits are pre-packaged for fast user

assembly and must be torqued down to the busbar prior to assembly. For VL breakers, adaptors are available for up to 500A breakers (both main and feeder orientation). See page 5/8.

3VA and GG Feeder Circuit Breakers

Bus bar system for 3VA circuit breakers are available from 15A up to 500A.

Type	Part Number
Busbar adapter system with 60 mm busbar center-to-center spacing, 3-pole	8US1211-4SS00
	8US1213-4AP03
	8US1213-4AH04

For molded case circuit breakers / SCCR Rating

3VA5 & GG 125A 65KA @ 480VAC	3VA5 250A 100KA @ 480VAC	3VA6 150A-250A 150KA @ 480VAC	3VA5 400A-500A 100KA @ 480VAC	3VA6 400A-500A 150KA @ 480VAC
✓	–	–	–	–
–	✓	✓	–	–
–	–	–	✓	✓

3VA and GG Main Circuit Breakers

Busbar adapter system with 60 mm busbar center-to-center spacing, top-fed, 15A to 125A 3-pole	8US1215-4SS00
	8US1213-4AP03
	8US1213-4AH04

✓	–	–	–	–
–	✓	✓	–	–
–	–	–	✓	✓

Design	UL Current Rating	Breaker Frame (SCCR Rating) ¹⁾		
Sentron and GG Feeder Circuit Breakers		ED (25kA)	HHED (65kA)	FXD (35kA)
 <p>3 pole/600V fully assembled breakers and adaptors that quickly snap onto the Busbar.</p> <p>FBCB100</p>	15A	FBCB015	–	–
	20A	FBCB020	FBCB020H	–
	25A	FBCB025	FBCB025H	–
	30A	FBCB030	FBCB030H	–
	35A	FBCB035	FBCB035H	–
	40A	FBCB040	FBCB040H	–
	45A	FBCB045	FBCB045H	–
	50A	FBCB050	FBCB050H	–
	60A	FBCB060	–	–
	70A	FBCB070	–	–
	80A	FBCB080	–	–
	90A	FBCB090	–	–
	100A	FBCB100	–	–
	110A	FBCB110	–	–
125A	FBCB125	–	–	
3 pole/600V kitted components for customer assembly that require the adaptor to be torqued down to the Busbars prior to assembly.	150A	–	–	FBCB150
	175A	–	–	FBCB175
	200A	–	–	FBCB200
	225A	–	–	FBCB225
	250A	–	–	FBCB250

Design	UL Current Rating	Breaker Frame (SCCR Rating) ¹⁾		
Sentron Main Circuit Breakers		FXD (25kA) ²⁾	HFXD (65kA) ²⁾	
 <p>3 pole/600V kitted components for customer assembly that require the adaptor to be torqued down to the Busbars prior to assembly.</p> <p>FBCB250M</p>	100A	FBCB100M	FBCB100M-HB	–
	125A	FBCB125M	FBCB125M-HB	–
	150A	FBCB150M	FBCB150M-HB	–
	175A	FBCB175M	FBCB175M-HB	–
	200A	FBCB200M	FBCB200M-HB	–
	225A	FBCB225M	FBCB225M-HB	–
	250A	FBCB250M	FBCB250M-HB	–





1) UL Short Circuit Current ratings are based on 480V.
 FBCB015 -125 SCCR = 18kA @ 600V
 FBCB015H -125H SCCR = 18kA @ 600V
 FBCB150 -250 SCCR = 22kA @ 600V

2) FBCB100M -125M SCCR = 18kA @ 600V
 FBCB150M -250M SCCR = 25kA @ 600V
 FBCB150M-HB -250M-HB SCCR = 25kA @ 600V

Fast Bus Busbar Adapter System

60 mm system – Busbar adapters and device holders

Selection and ordering data

Busbar device adapters	Number of mounting rails (35 mm)	Rated current	Con-necting cables	Adapter length	Adapter width	Rated voltage UL	UL508A ¹⁾ compliance	Order No.	Pack units	Weight per PU approx . kg
		A	AWG	mm	mm	V				
For SIRIUS										
Size S00/S0										
 8US21 51-5DM07	MSPs	1	25	12	182	45	600	yes	8US12 51-5DM07	0.183
	Contactors + Overload relays	1	25	12	182	45	600	yes		
	Direct start load feeders	1	25	12	182	45	600	yes		
	Reversing feeders									
	Busbar adapters	1	25	12	182	45	600	yes	8US12 51-5DM07	0.183
	+ Device holders	1	--	--	182	45	600	yes	8US12 50-5AM00	0.158
+ Connecting plates	--	--	--	--	--	--	yes	8US19 98-1AA00	100 units	0.100
Size S00/S0 Cage Clamp										
 8US21 60-5AM00	Direct start load feeders	1	12	14	182	45	600	yes	8US12 51-5CM47	0.190
Size S2										
 8US12 11-4TR00	MSPs	1	50	8	182	55	600	yes	8US12 61-5FM08	0.263
	Contactors + Overload relays	1	50	8	182	55	600	yes		
	Direct start load feeders	1	50	8	245	55	600	yes	8US12 61-5FP08	0.292
	Reversing feeders									
	Busbar adapters	1	50	8	242	55	600	yes	8US12 61-5FP08	0.292
	Busbar adapters	1	--	--	242	55	600	yes	8US12 60-5AM00	0.202
+ Device holders	--	--	--	242	55	600	yes	8US12 60-5AP00	0.243	
+ Connecting plates	--	--	--	--	--	--	yes	8US19 98-1AA00	100 units	0.100
Size S3										
			80	4	215	72	600	yes	8US12 11-4TR00⁴⁾	0.659
	1	100	--	200	72	600	yes	FBS100723R	0.590	
	--	100	--	200	72	600	yes	FBS100722	0.610	
For VL UL circuit breakers²⁾										
 8US12 13-4AQ03	VL150 UL, DG frame	--	150	Tubular contacts	190	105	600	yes	8US12 13-4AQ03	1.020
	VL250 UL, FG frame	--	250	Tubular contacts	190	105	600	yes	8US12 13-4AQ03	1.020
	VL400 UL, JG frame	--	400	Tubular contacts	296	140	600	yes	8US12 13-4AH00	1.900
	VL400X UL, LG frame	--	540 ³⁾	Tubular contacts	296	140	600	yes	8US12 13-4AH00	1.900
 8US12 13-4AH00			Tubular							









¹⁾ UL 508A labeled panels require the use of components that meet the creepage and air distances of 1" air clearance and 2" creepage distance. N/A = not applicable for given item.

²⁾ For use with 10mm x 30mm and twin T (TT) busbars only. Adaptors can be configured for main or feeder breakers applications.

³⁾ For use with maximum 500A circuit breaker. Circuit breakers greater than 500A must be panel mounted off the busbar system and fed to the busbars via an infeed module. See page 5/6.

⁴⁾ Rated 100A @ 480V. Rated 100A @ 600V with Class J Fuses.

Selection and ordering data

Description	Max Amps	Width	UL508A Compliance ¹⁾	Order No.	List Price \$	Pack Units
Terminals for round conductors						
5 mm busbar thickness³⁾						
 Terminals	12 mm x 5 mm	180	16 - 6 AWG	8US19 21-2AA00		100
	15 mm x 5 mm	270	12 - 2 AWG	8US19 21-2AB00		50
	20 mm x 5 mm	400	6 - 2/0 AWG	8US19 21-2AD00		50
	25 mm x 5 mm	440	6 - 250 MCM	8US19 21-2AC00		50
	30 mm x 5 mm	180	16 - 6 AWG	8US19 21-2AA01		15
		270	12 - 2 AWG	8US19 21-2AB01		15
		400	6 - 2/0 AWG	8US19 21-2AD01		15
		440	6 - 250 MCM	8US19 21-2AC01		15
	20 mm x 5 mm, 25 mm x 5 mm	500	3/0 - 350 MCM	8US19 41-2AA01		6
	30 mm x 5 mm	600	300 - 600 MCM	8US19 41-2AA02		3
10 mm bar thickness						
 Terminals	12 mm x 10 mm ³⁾	180	16 - 6 AWG	8US19 21-2BA00		100
	15 mm x 10 mm ³⁾ , 20 mm x 10 mm	270	12 - 2 AWG	8US19 21-2BB00		50
	25 mm x 10 mm, 30 mm x 10 mm	400	6 - 2/0 AWG	8US19 21-2BD00		50
		440	6 - 250 MCM	8US19 21-2BC00		50
		180	16 - 6 AWG	8US19 21-2BA01		15
		270	12 - 2 AWG	8US19 21-2BB01		15
		400	6 - 2/0 AWG	8US19 21-2BD01		15
		440	6 - 250 MCM	8US19 21-2BC01		15
	20 mm x 10 mm, 25 mm x 10 mm	500	3/0 - 600 MCM	8US19 41-2AA01		6
	30 mm x 10 mm	600	300 - 600 MCM	8US19 41-2AA02		3
Terminal covers for circular conductors (mounts to busbars)						
 8US19 22-1GA00	For terminals up to 250 MCM 200 mm long, 84 mm wide			8US19 22-1GA00		10
	For terminals up to 600 MCM 200 mm long, 270 mm wide			8US19 22-1GA02		1
	For terminals up to 600 MCM 200 mm long, 135 mm wide			FBC135		
Accessories for busbar adapters and device holders						
 Mounting Rail	Mounting rail (35 mm) - plastic complete with mounting screws	45 mm	n/a	8US1998-7CA15		10
		55 mm	n/a	8US1998-7CA16		10
		70 mm	n/a	8US1998-4AA00		10
		90 mm	n/a	8US1998-7CA08		10
		110 mm	n/a	8US1998-7CA10		10
 8US1998-1DA00	Connection holder (for vertical busbar assembly) fixes the MSP to the mounting rail ³⁾ (for SIRIUS sizes S00/S0)	-	n/a	8US1998-1DA00		20
	Screw holder for supplementary screw fixing of the feeder (for SIRIUS sizes S00/S0)	-	n/a	8US1998-1CA00		20
 8US1998-1BA00	Spacer fixes the busbar adapter to the device holder (for SIRIUS sizes S00/S0)	-	n/a	8US1998-1BA00		100
		-	n/a	8US1998-1BA01		1
 FBC20	Connection wedges for mechanical linking of adapters and switching device holders (2 units required per combination)	-	n/a	FBC20		20
	Outgoing terminal rail for busbar adapters					
 Load Side Terminal	Plug-type terminal (complete with supporting element for attaching to busbar adapter and switching device holder. Spring loaded terminals.)					
	3 x 14 AWG (400 V) and 4 x 16AWG (250 V)	91 mm	45 mm	n/a	8US1998-8AM07	
	7 x 14 AWG (400 V)	91 mm	54 mm	n/a	8US1998-8AA10	
Accessories for busbar adapters and device holders						
 8US1998-2BM00	Side module for busbar adapter expansion For adapters w/182 mm	182 mm	10 mm	n/a	8US1998-2BM00	
	Side module for busbar adapter expansion For adapters w/200 mm	200 mm	9 mm	n/a	8US1998-2BJ10	

¹⁾ UL508A labeled panels require the use of components that meet the creepage and air distances of 1" air clearance and 2" creepage distance.
N/A = not applicable for given item.

²⁾ Terminals must be manually spaced on the busbar to comply with UL508A distances of 1" air clearance and 2" creepage distance.

³⁾ Cannot be used on Twin T (TT) profile up to 1400 A.

Fast Bus Busbar Adapter System

60 mm system

Dimension drawings

FBB36/FBB60 Copper Busbar

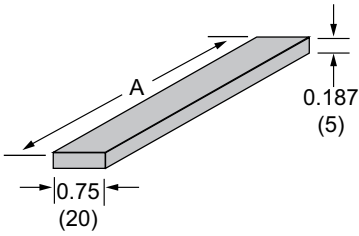

Dimension	A
FBB36	36 (914)
FBB60	60 (1524)

8US19 23-3UA01

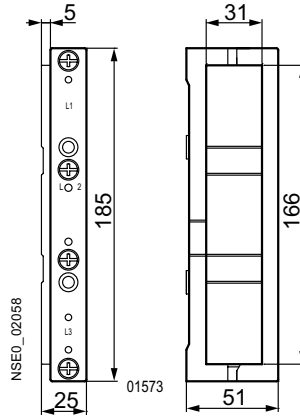

8US19 43-3AA00

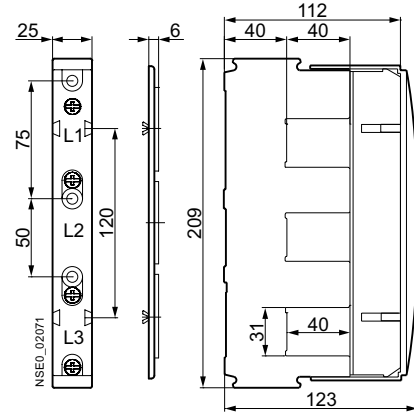

Copper Busbar/TT profile, 8US19 48-2AA00

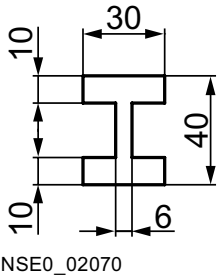

8US19 22-1AC00 with 8US19 23-3UA01
8US19 22-1AC00 with 8US19 23-3AA01

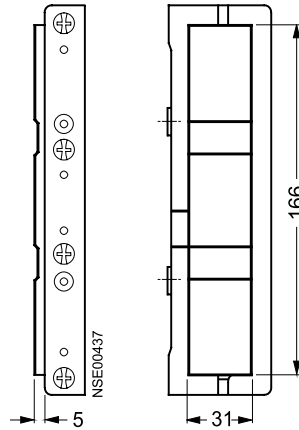

Support for blanking covers, 8US1922-2EA00

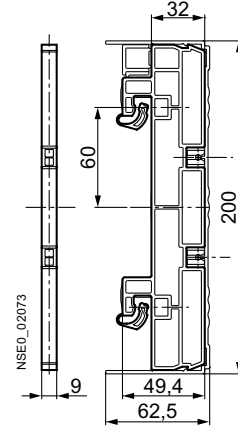

8US19 23-1AA01

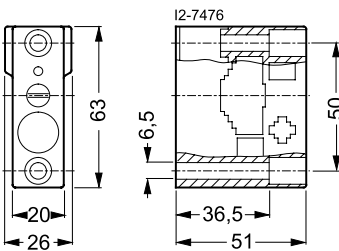

8US19 22-2AA00

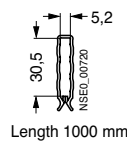

8US19 22-2BA00

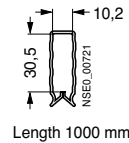

8US19 22-2DA00

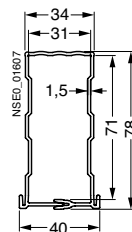

Blanking cover, 8US1922-2EB00

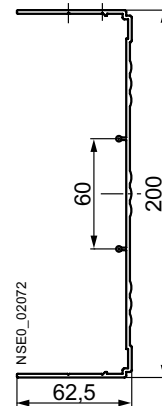

Dimension drawings

Infeed, 8US19 21-1BA00

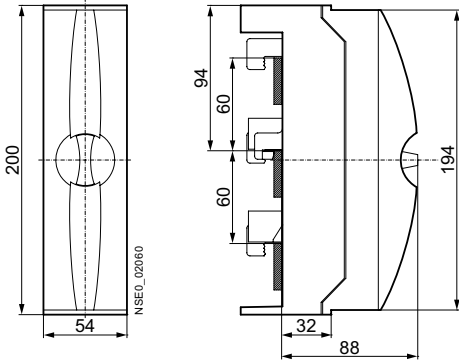

Infeed, 8US19 41-2AA03

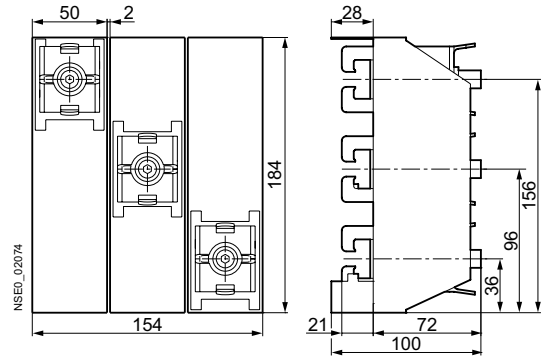

Infeed, 8US19 21-1AA00

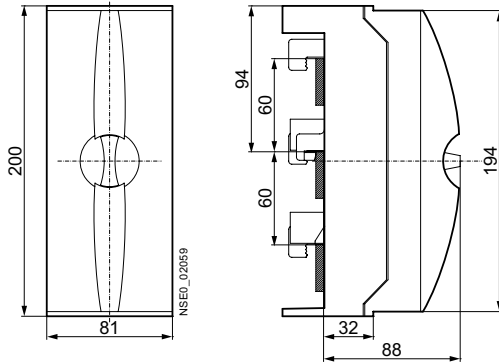

Infeed, 8US19 41-2AA04

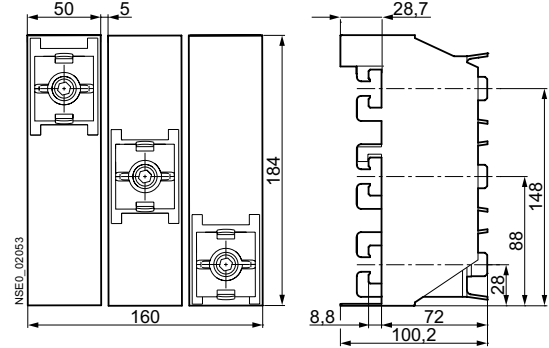

Infeed 5SH3538

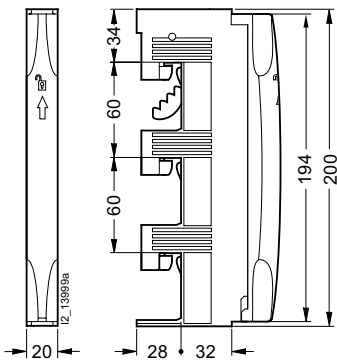

FBT600F (supplied with cover)

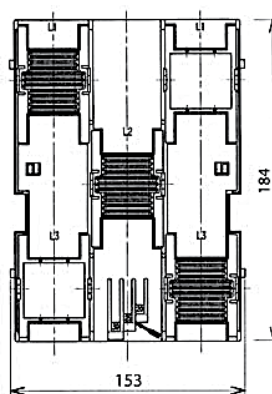

FBT600F Cover

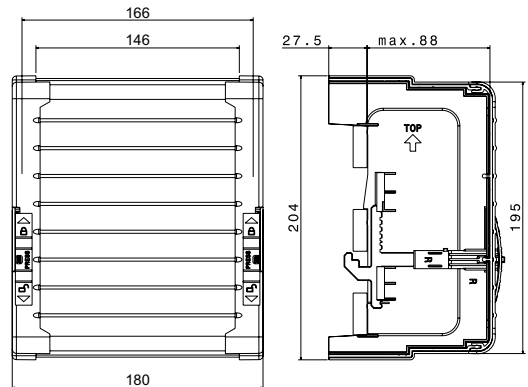

Dimension drawings

Busbar device adapter, 8US12 50-5AM00

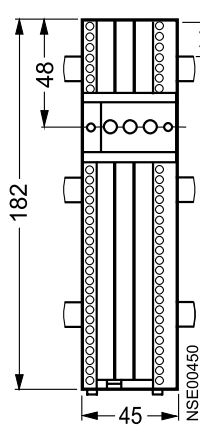

Busbar device adapter, 8US12 60-5AP00

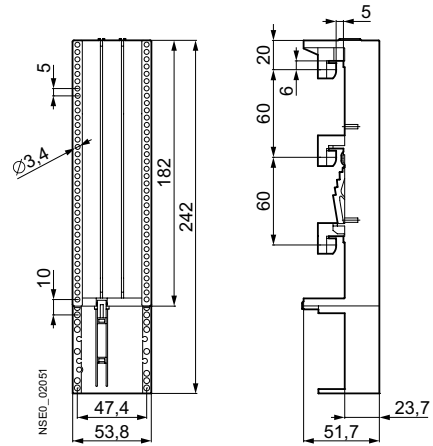

Busbar device adapter, 8US12 61-5FM08

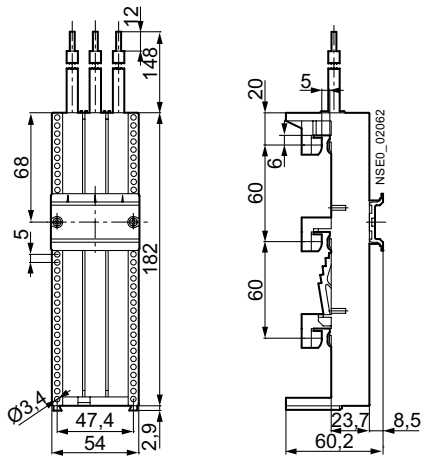

Busbar device adapter, 8US12 11-4TR00

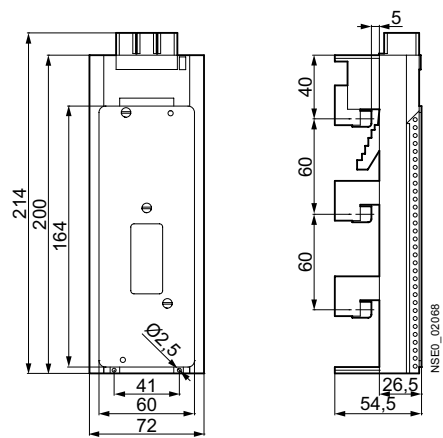

Busbar device adapter, 8US12 51-5DM07

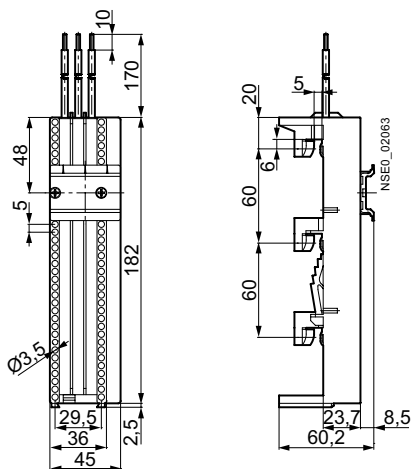

Busbar device adapter, 8US12 61-5FP08

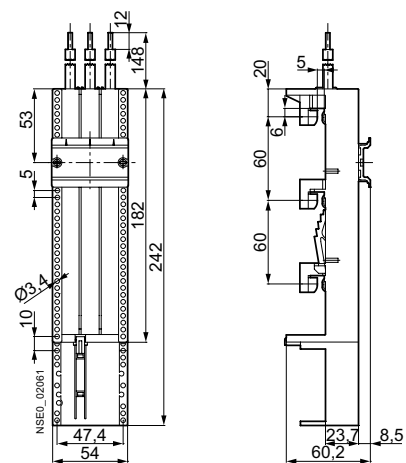

Dimension drawings

Busbar device adapter, 8US12 51-5CM47

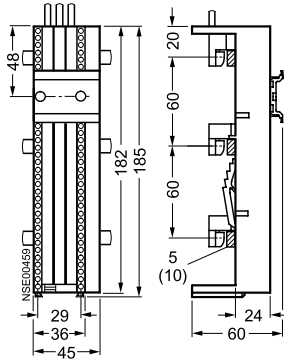

Busbar device adapter, 8US12 13-4AQ01

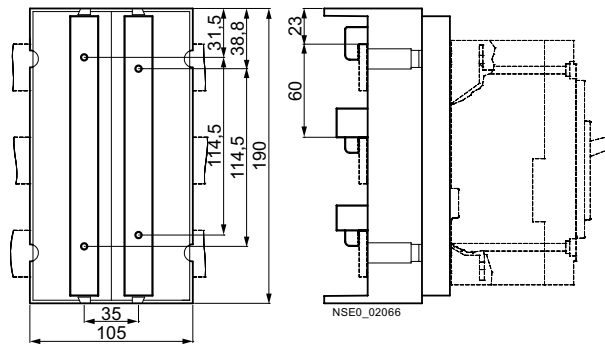

8US19 98-2BM00

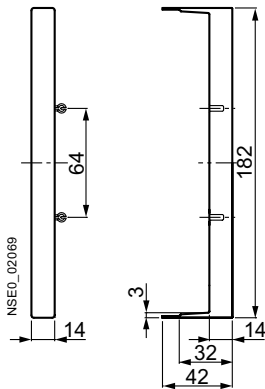

Busbar device adapter, 8US12 13-4AQ03

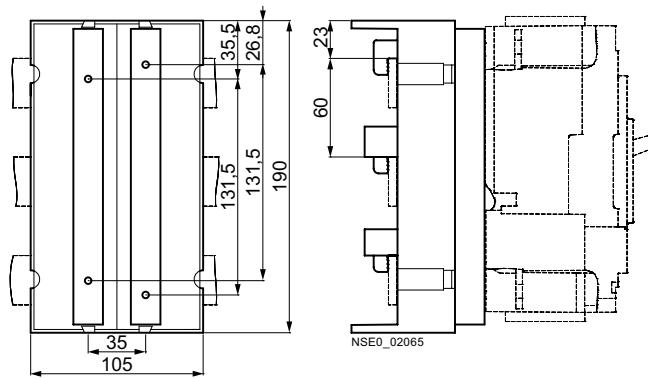

Busbar device adapter, 8US12 13-4AH00

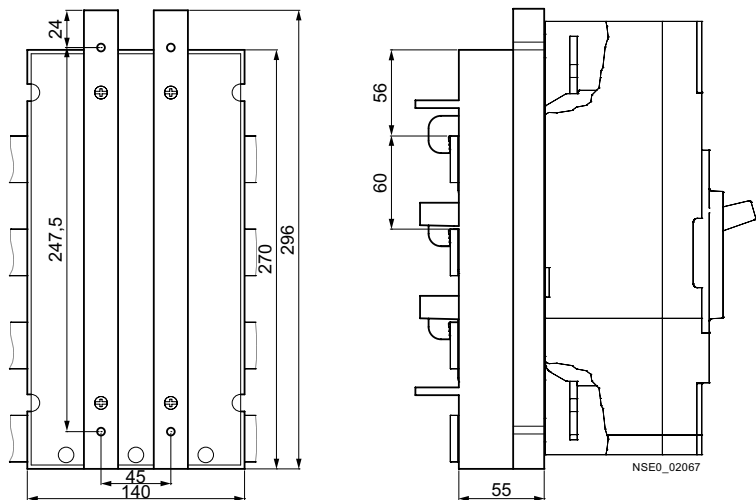

Fast Bus Busbar Adapter System

60 mm system

Dimension drawings

Type	a	b	c	d	e	f	Max tightening torque	
5mm	8US1921-2AA0.	7.5	11.5	22.5	25	5	10	4 Nm
	8US1921-2AB0.	10.5	15.5	29	35	5	10	6 Nm
	8US1921-2AC0.	17	23.5	36	55	5	12	15 Nm
	8US1921-2AD0.	14.5	20.5	32	42	5	12	10 Nm
10mm	8US1921-2BA0.	7.5	11.5	22.5	25	10	10	4 Nm
	8US1921-2BB0.	10.5	15.5	29	35	10	10	6 Nm
	8US1921-2BC0.	17	23.5	36	55	10	12	15 Nm
	8US1921-2BD0.	14.5	20.5	32	42	10	12	10 Nm

8US1941-2AA01

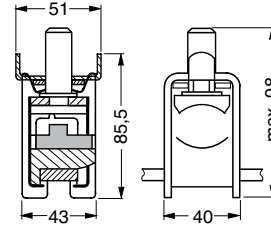

8US1921-2A / -2B

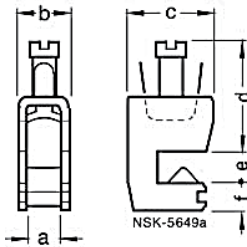

8US1941-2AA02

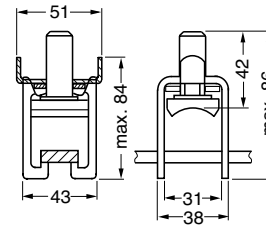

FBC135

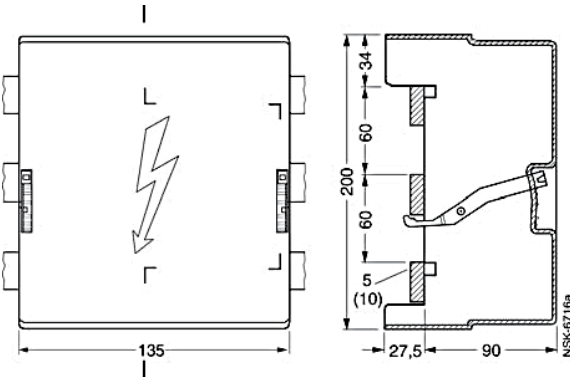

8US1922-1GA00

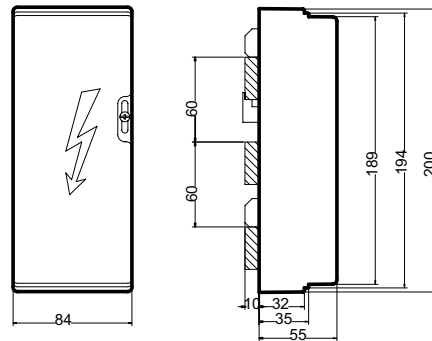

8US19 22-1GA02

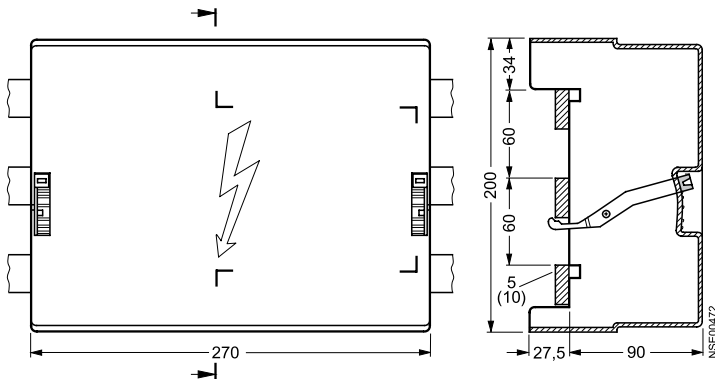

Dimension drawings

8US19 98-1CA00

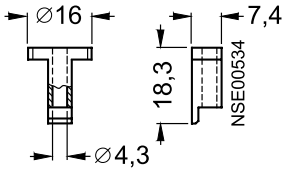

8US19 98-1DA00

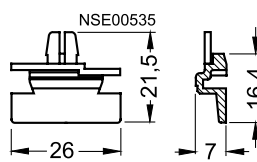

8US19 98-4AA00

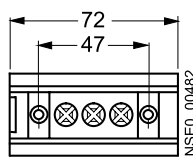

8US19 98-7CA08

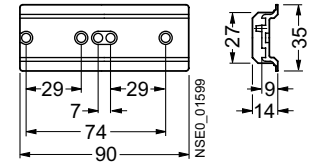

8US19 98-7CA10

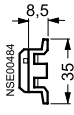
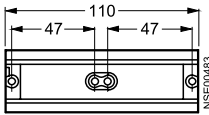

8US19 98-7CA15

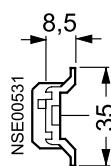
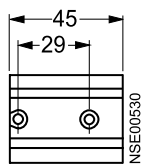

8US19 98-7CA16

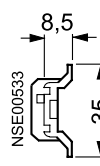
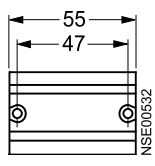

8US19 98-1BA00

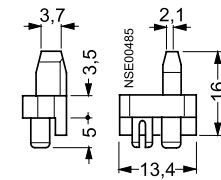

8US19 98-8AM07

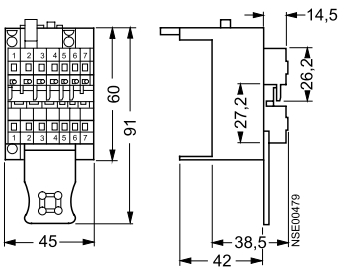

8US19 98-8AA10

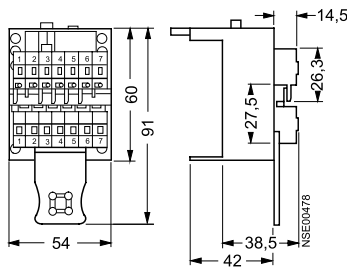

8US19 98-1CA00

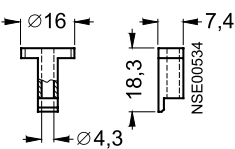

8US19 98-1DA00

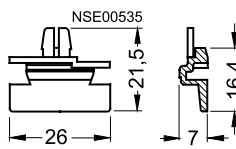

General data

Order No. scheme

Digit of the Order No.	1st - 3rd	4th	5th	6th	7th	8th	9th	10th	11th	12th	13th	14th	15th	16th
	□□□	□	□	□	0	-	□	□	□	□	-	□	□	□
SIRIUS starters	3 R A													
SIRIUS 2nd generation	2													
Type of starter (direct-on-line starter = 1, reversing starter = 2)	□													
Size (S00 = 1, S0 = 2)	□													
Setting range for overload release	□ □													
Design type and connection method	□													
Rated power at 460 V AC	□ □													
Integrated auxiliary switches of the contactor	□													
Operating range / solenoid coil circuit (contactor)	□													
Rated control supply voltage (contactor)	□ □													
Example	3 R A 2 1 1 0 - 0 B A 1 5 - 1 A K 6													

Note:

The Order No. scheme is presented here merely for information purposes and for better understanding of the logic behind the order numbers. For your orders, please use the order numbers quote in the catalog in the Selection and ordering data.

Technical specifications

Direct-on-line starters/ reversing starters	Size	Connection methods	Mounting	Control voltage	Width W	Height H	Depth D	
					mm	mm	mm	
Mounting dimensions								
Direct-on-line starters 3RA21.	S00	Screw terminals	Standard mounting rails	AC/DC	45	167	97	
			Busbar adapters	AC/DC	45	200	155	
	Spring-type terminals	Standard mounting rails	AC/DC	45	198	97		
		Busbar adapters	AC/DC	45	260	155		
	S0 3RA21 2.	Screw terminals	Standard mounting rails	AC	45	193	97	
				DC	45	193	107	
		Busbar adapters	AC	45	260	155		
			DC	45	260	165		
		Spring-type terminals	Standard mounting rails	AC/DC	45	243	107	
			Busbar adapters	AC/DC	45	260	165	
	Reversing starters 3RA22.	S00	Screw terminals	Standard mounting rails	AC/DC	90	170	97
				Busbar adapters	AC/DC	90	200	155
Spring-type terminals		Standard mounting rails	AC/DC	90	204	97		
		Busbar adapters	AC/DC	90	260	155		
S0 3RA22 2.		Screw terminals	Standard mounting rail adapters	AC	90	265	120.3	
				DC	90	265	130	
		Busbar adapters	AC	90	260	155		
			DC	90	260	165		
		Spring-type terminals	Standard mounting rail adapters	AC/DC	90	270	131	
			Busbar adapters	AC/DC	90	260	165	

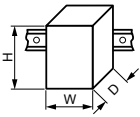

Type		3RA2. 1	3RA2. 2
Size		S00	S0
Number of poles		3	3
Mechanics and environment			
Permissible ambient temperature			
• During operation	°C	-20 ... +60	
• Storage and transport	°C	-55 ... +80	
Weight	kg	0.6 ... 1.5	0.8 ... 2.3
Permissible mounting positions			
		Important: Acc. to DIN 43602 start command "I" at the right or top	
Shock resistance (sine-wave pulse)	Acc. to IEC 60086 Part 2-27	g	Up to 6
Degree of protection	Acc. to IEC 60947-1	IP20	

SIRIUS 3RA Motor Starters

General data

Direct-on-line starting · For 60 mm busbar systems · Sizes S00 and S0

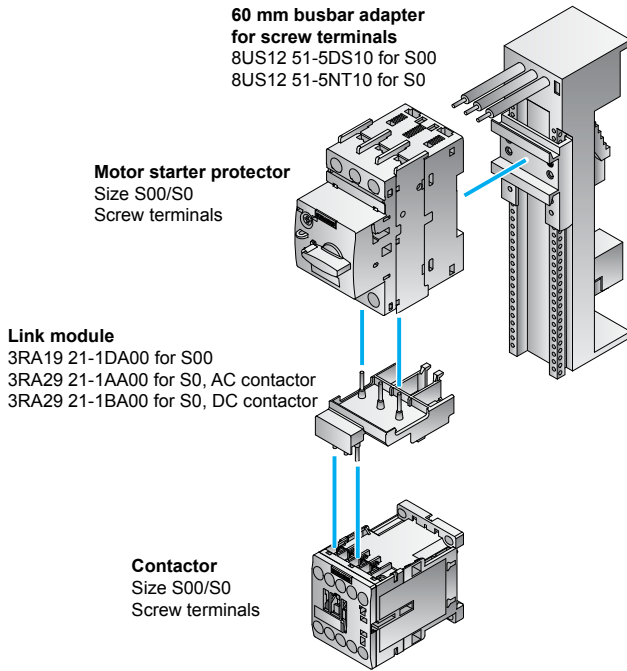

Left: 3RA21 motor starter for direct-on-line starting with busbar adapters with screw connection

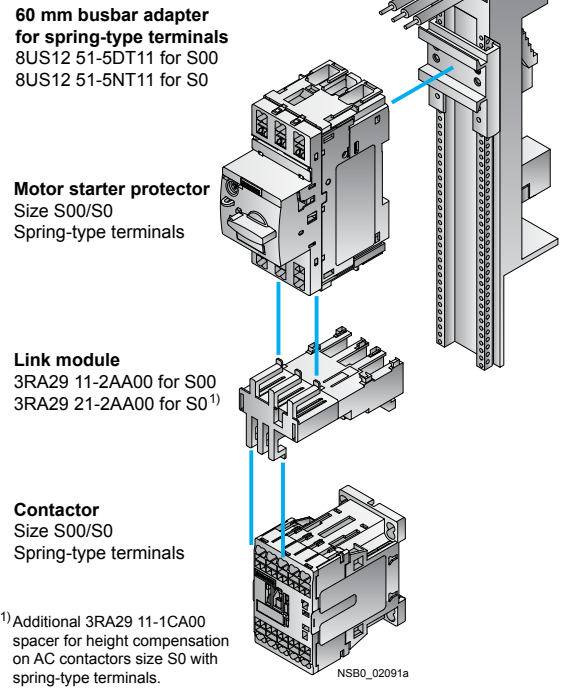

Right: 3RA21 motor starter for direct-on-line starting with busbar adapters with spring-type connection

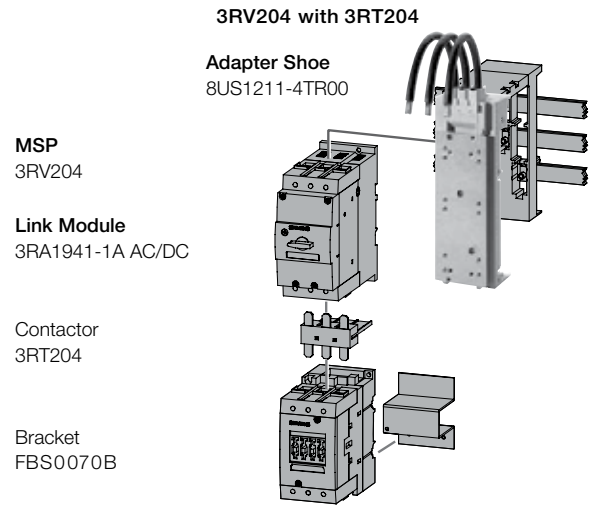
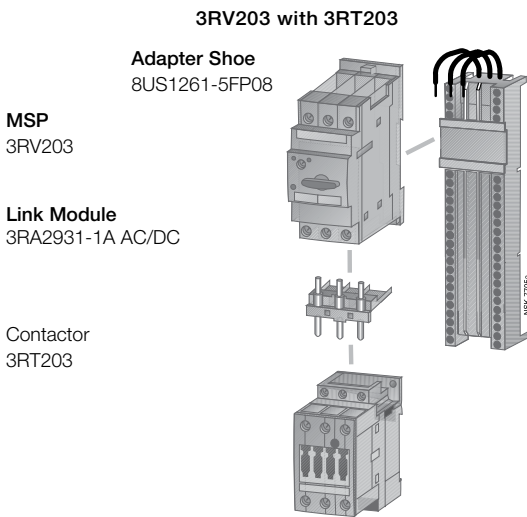

Reversing duty • For 60 mm busbar systems • Sizes S00 and S0

RS assembly kit for reversing duty and busbar mounting

Screw connection:
 3RA29 13-1DB1 for S00
 3RA29 23-1DB1 for S0

For spring-type connection:
 3RA29 13-1DB2 for S00
 3RA29 23-1DB2 for S0¹⁾

Comprising:
 1 wiring kit
 1 busbar adapter
 1 device holder
 2 connecting wedges

¹⁾Also includes 3RA29 11-1CA00 spacer for height compensation on AC contactors size S0 with spring-type terminals.

Motor starter protector

Size S00/S0
 Screw terminals/
 spring-type terminals

Link module

For screw terminals:
 3RA19 21-1DA00 for S00
 3RA29 21-1AA00 for S0, AC contactor
 3RA29 21-1BA00 for S0, DC contactor
 For spring-type terminals:
 3RA29 11-2AA00 for S00
 3RA29 21-2AA00 for S0²⁾

60 mm busbar adapter

For screw terminals:
 8US12 51-5DS10 for S00
 8US12 51-5NT10 for S0
 For spring-type terminals:
 8US12 51-5DT11 for S00
 8US12 51-5NT11 for S0

2 connecting wedges
 8US19 98-1AA00

60 mm device holder
 8US12 51-5AS10

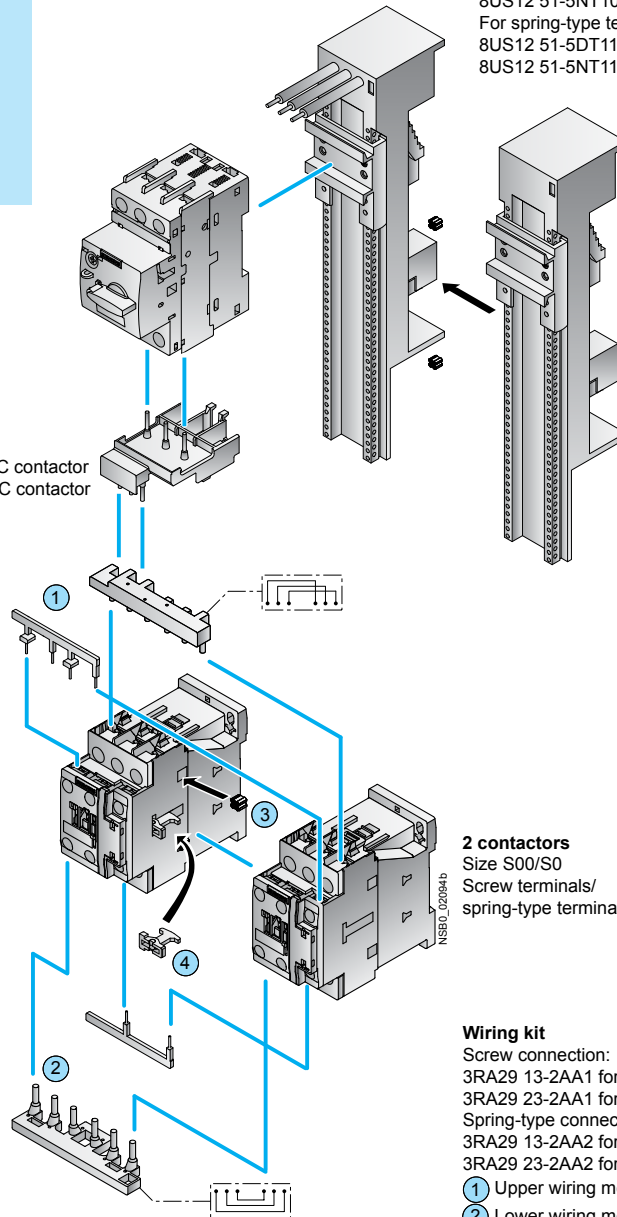

2 contactors
 Size S00/S0
 Screw terminals/
 spring-type terminals

Wiring kit

Screw connection:
 3RA29 13-2AA1 for S00
 3RA29 23-2AA1 for S0

Spring-type connection:
 3RA29 13-2AA2 for S00
 3RA29 23-2AA2 for S0

- ① Upper wiring module
- ② Lower wiring module
- ③ 2 connecting clips
- ④ Mechanical interlock (can be removed if necessary)

²⁾Additional 3RA29 11-1CA00 spacer for height compensation on AC contactors size S0 with spring-type terminals.

3RA22 motor starter for reversing duty and 60 mm standard mounting rail in size S00/S0 (the version with screw connection is shown in the picture)

Selection

Required Components for Fast Bus Mounting

- ① Link Module
3RA2931-1A AC/DC
- ② Mechanical Interlock
3RA2934-2B
- ③ Fast Clips
FBC20

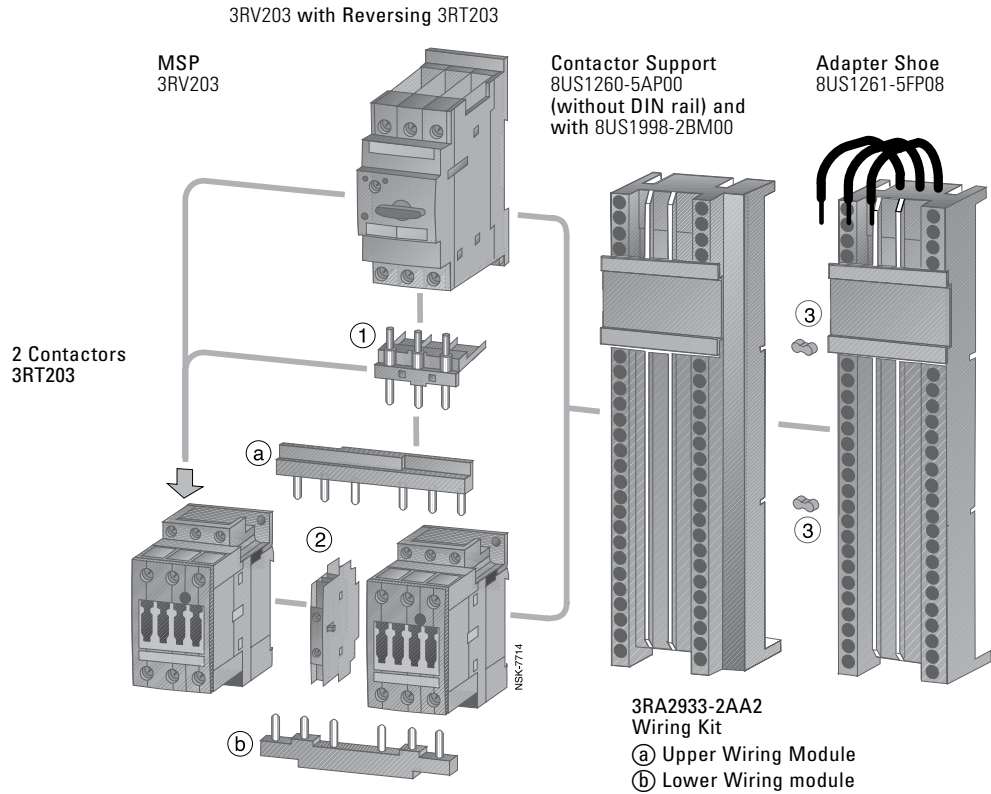

- ① Link Module
3RA1941-1A AC/DC
- ② Mechanical Interlock
3RA2934-2B

- 3RA2943-2AA1
Wiring Kit
a) Upper Wiring Module
b) Lower Wiring Module

2 Contactors
3RT204

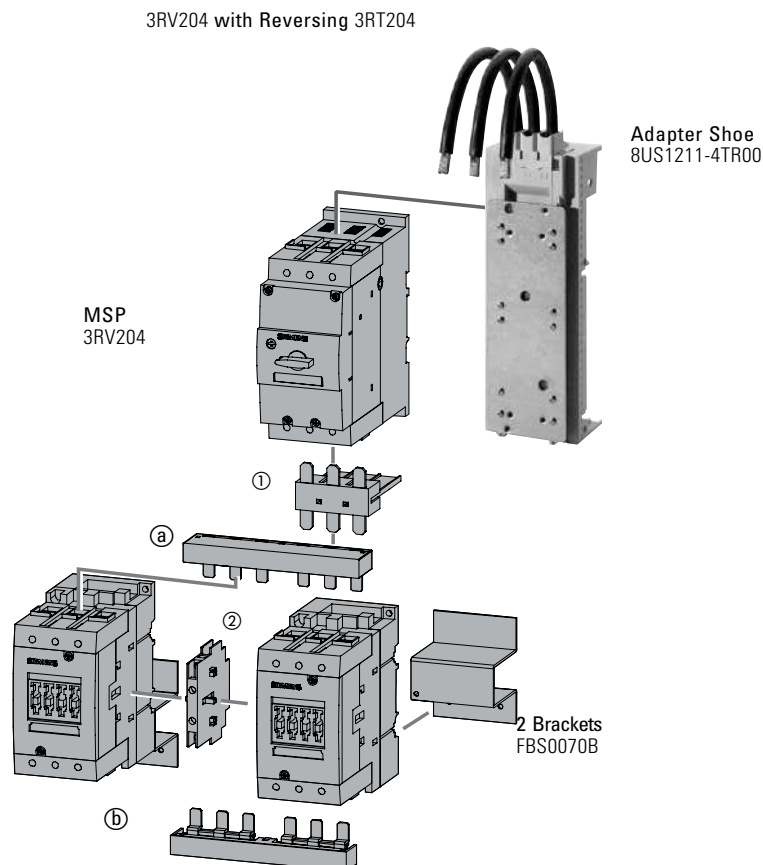

Dimensions

Dimensions, 3RV201 with 3RT201

3RA2110
Fast Bus Non-reversing

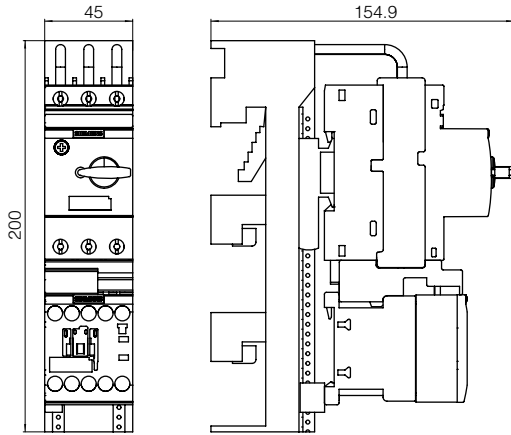

3RA2210
Fast Bus Reversing

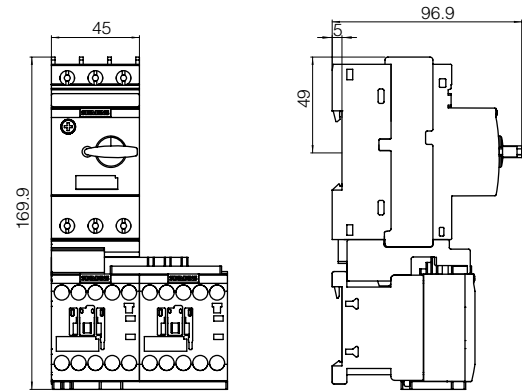

- 1) Lockable in OFF position. Padlock diameter 5 mm.
- 2) When a front auxiliary is installed on the contactor, add 44 mm to the depth of the contactor.

Dimensions, 3RV202 with 3RT201

3RA2120
Fast Bus Non-reversing

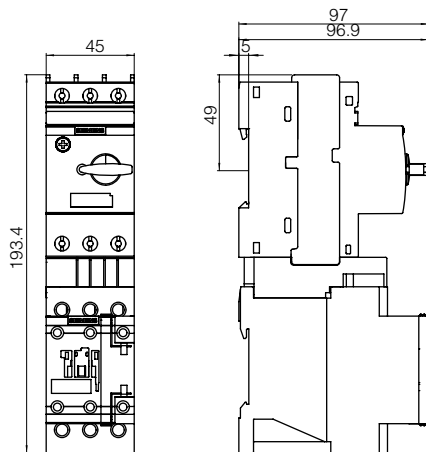

3RA2220
Fast Bus Reversing

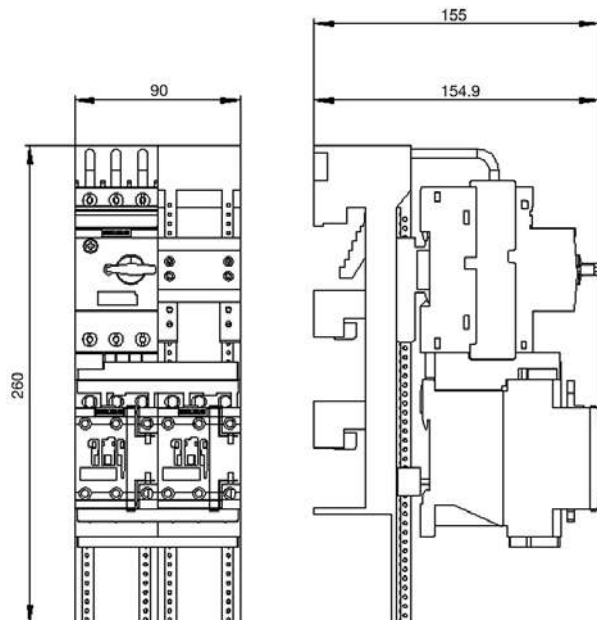

- 1) Lockable in OFF position. Padlock diameter 5 mm.
- 2) When a front mount auxiliary is installed on the contactor, add 44 mm to the depth of the contactor.

All dimensions shown in millimeters. For reference purposes only. Not to be used for design or construction purposes.

Dimensions

3RV203 with 3RT203

3RA2130
Fast Bus Non-reversing

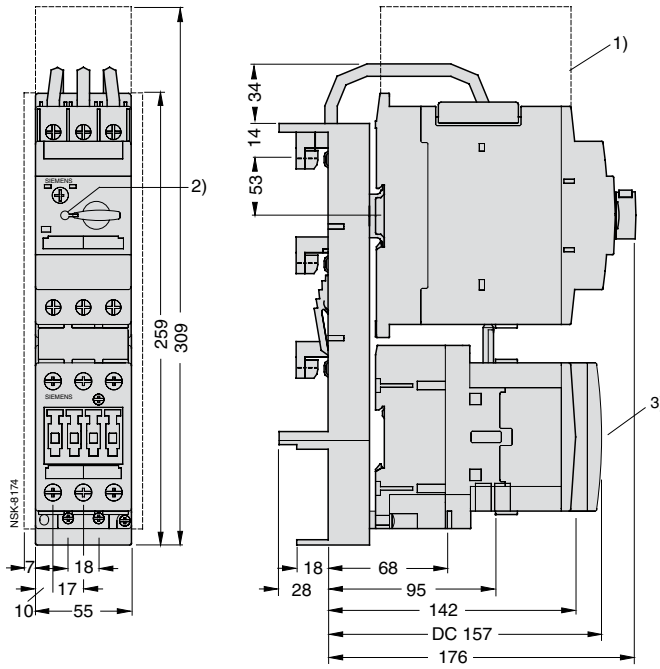

3RA2230
Fast Bus Reversing

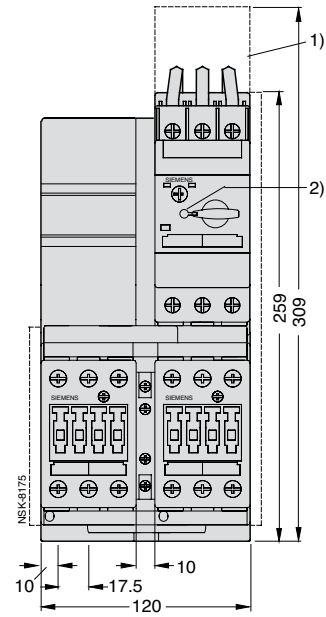

Lateral clearance to grounded components minimum 6 mm.

- 1) Arcing space
- 2) Lockable in OFF position with padlock diameter 5 mm.
- 3) When a front mount auxiliary is installed on the contactor, add 49 mm to the depth of the contactor.

All dimensions shown in millimeters. For reference purposes only. Not to be used for design or construction purposes.

Dimensions

3RV204 with 3RT204

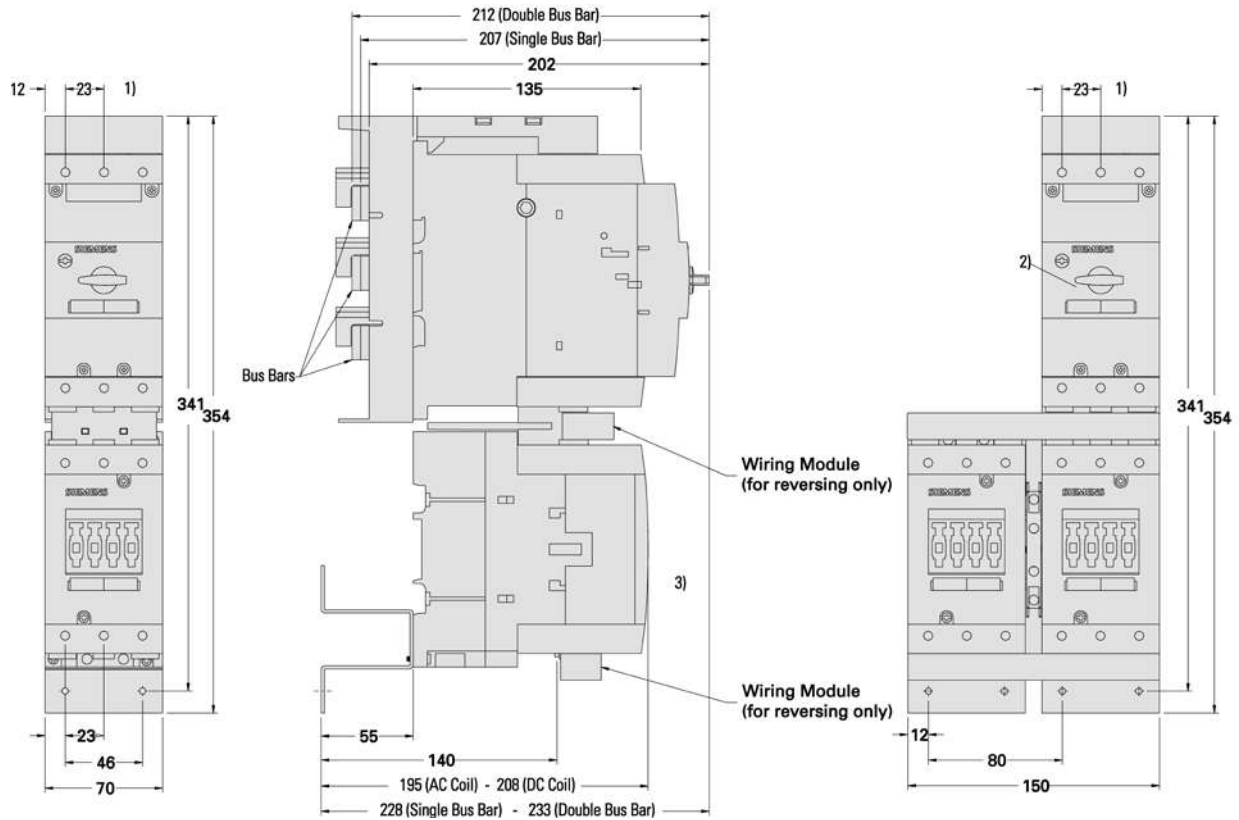

Lateral clearance to grounded components minimum 6 mm.

- 1) Arcing space
- 2) Lockable in OFF position with padlock diameter 5 mm.
- 3) When a front mount auxiliary is installed on the contactor, add 49 mm to the depth of the contactor.

All dimensions shown in millimeters. For reference purposes only. Not to be used for design or construction purposes.