



INSTALLATION & OPERATION

EVENT ANALYZER RECORDER (SEAR II) A80273

MARCH 2014 (REVISED MAY 2021)

**DOCUMENT NO. SIG-00-02-07
VERSION B7**

Siemens Mobility, Inc.
700 East Waterfront Drive
Munhall, Pennsylvania 15120
1-800-793-SAFE
www.usa.siemens.com/rail-manuals

Copyright © 2021 Siemens Mobility, Inc.
All Rights Reserved

PRINTED IN THE U.S.A.

PROPRIETARY INFORMATION

The material contained herein constitutes proprietary and confidential information, and is the intellectual property of Siemens Mobility, Inc. (Siemens) protected under United States patent, copyright and/or other laws and international treaty provisions. This information and the software it describes are for authorized use only, and may not be: (i) modified, translated, reverse engineered, decompiled, disassembled or used to create derivative works; (ii) copied or reproduced for any reason other than specific application needs; or (iii) rented, leased, lent, sublicensed, distributed, remarketed, or in any way transferred; without the prior written authorization of Siemens. This proprietary notice and any other associated labels may not be removed.

TRANSLATIONS

The manuals and product information of Siemens Mobility, Inc. are intended to be produced and read in English. Any translation of the manuals and product information are unofficial and can be imprecise and inaccurate in whole or in part. Siemens Mobility, Inc. does not warrant the accuracy, reliability, or timeliness of any information contained in any translation of manual or product information from its original official released version in English and shall not be liable for any losses caused by such reliance on the accuracy, reliability, or timeliness of such information. Any person or entity that relies on translated information does so at his or her own risk.

WARRANTY INFORMATION

Siemens Mobility, Inc. warranty policy is as stated in the current Terms and Conditions of Sale document. Warranty adjustments will not be allowed for products or components which have been subjected to abuse, alteration, improper handling or installation, or which have not been operated in accordance with Seller's instructions. Alteration or removal of any serial number or identification mark voids the warranty.

SALES AND SERVICE LOCATIONS

Technical assistance and sales information on Siemens Mobility, Inc. products may be obtained at the following locations:

SIEMENS MOBILITY, INC.

2400 NELSON MILLER PARKWAY

LOUISVILLE, KENTUCKY 40223

TELEPHONE: (502) 618-8800

FAX: (502) 618-8810

SALES & SERVICE: (800) 626-2710

WEB SITE: www.usa.siemens.com/rail-manuals

SIEMENS MOBILITY, INC.

939 S. MAIN STREET

MARION, KENTUCKY 42064

TELEPHONE: (270) 918-7800

CUSTOMER SERVICE: (800) 626-2710

TECHNICAL SUPPORT: (800) 793-7233

FAX: (270) 918-7830

FCC RULES COMPLIANCE

The equipment covered in this manual has been tested and found to comply with the limits for Class A digital devices, pursuant to part 15 of the FCC Rules. These limits are designed to provide reasonable protection against harmful interference when the equipment is operated in a commercial environment. This equipment generates, uses, and can radiate radio frequency energy and, if not installed and used in accordance with the instruction manual, may cause harmful interference to radio communications. Operation of this equipment in a residential area is likely to cause harmful interference in which case the user will be required to correct the interference at his/her own expense.

DOCUMENT HISTORY

Version	Release Date	Details of Change(s)
A	Aug 2002	New I & O manual for new product (SEAR II).
B	Jan 2004	<ul style="list-style-type: none"> • Section 1 – Introduction: page 1-14, section 1.5.2.3 has been added to present information on the new SDIM and SDIMFE expansion modules • Section 3 – Operation: extensively revised to reflect changes to the operator interface.
B1	Sept 2005	<ul style="list-style-type: none"> • Minor formatting change to consolidate individual Tables of Contents. • Section 1 – Introduction: <ul style="list-style-type: none"> ○ Page 1-1, Paragraph 1.1 – Expanded Warning about SEAR II being a non-vital product, and precautions about interfacing with other vital equipment. ○ Page 1-17, Paragraph 1.6.3 – Added Caution stating if an application causes the impedance of digital inputs to exceed 10K ohms, it could contribute to an unsafe condition. ○ Page 1-18, Paragraph 1.6.3 – Added Warning about monitoring vital relay coils, each digital input must be wired directly to the relay terminals. • Section 2 – Installation: <ul style="list-style-type: none"> ○ Page 2-10, Paragraph 2.1.11.2 – Inserted “spare” to describe relay contacts, and added paragraph explaining that spare relay contacts on digital inputs can be daisy-chained, but vital relay coils must be connected directly to relay terminals. ○ Page 2-10, Paragraph 2.1.11.2 – Added Warning about SEAR II being a non-vital product, and precautions about interfacing with other vital equipment. ○ Page 2-11, Figure 2-3 – Modified drawing to show examples of digital input connections being connected directly to typical vital relay coil terminals. ○ Page 2-11, Figure 2-3 – Added Warning about monitoring vital relay coils, each digital input must be wired directly to the relay terminals.
B2	Mar 2007	Section 1, Specifications – Power Supply, paragraph 1.6.1: Added Isolation specification.
B3	Aug 2008	Added Appendix A covering installation of ferrite EMI filters on power and Echelon cables. Included references to Appendix A in Section 2, paragraphs 2.1.4 and 2.1.5.

Version	Release Date	Details of Change(s)
B4	Feb 2009	<ul style="list-style-type: none"> • Added Translations disclaimer in document front matter. • Added references to new “Basic” Event Report option in several places. • Added “System” menu selection option in terminal main menu. • Corrected selection options in both terminal and LUI menu selection lists. • Updated Figures 3-7 & 3-8 - terminal and LUI interface menu maps.
B5	June 2010	<ul style="list-style-type: none"> • Paragraph 1.6.3 <u>A80273</u> (SEAR II) Digital specifications: <ul style="list-style-type: none"> ○ Clarified that energized and de-energized thresholds are in VDC. ○ Added note to clarify input circuit thresholds, de-bounce application , and differences between DC and AC voltage monitoring.
B6	Mar 2014	<ul style="list-style-type: none"> • Updated to Siemens format, reformatted title page, prop FCC page and entire body per Siemens Rail Automation specification. • Changed recommendations for replacing the internal lithium battery in the SEAR II under the following conditions, per Siemens Rail Automation Product Information Bulletin PIB 2-14. <ul style="list-style-type: none"> ○ Page 1-7 – If the SEAR II is powered off for a continuous period of time, to ensure data retention Siemens Rail Automation recommends replacing the battery after every 2 months of inactivity. ○ Page 1-8 – During normal operation Siemens Rail Automation recommends replacing the battery after every 2 years of operation, rather than waiting for a low-battery warning alarm.
B7	May 2021	Added table to Section 1.3 to update references to manuals associated with this product.

Table Of Contents

PROPRIETARY INFORMATION.....	II
TRANSLATIONS	II
WARRANTY INFORMATION.....	II
DOCUMENT HISTORY	III
NOTES, CAUTIONS, AND WARNINGS	IX
ELECTROSTATIC DISCHARGE (ESD) PRECAUTIONS	X
1.0 INTRODUCTION.....	1-1
1.1 GENERAL.....	1-1
1.2 SCOPE	1-1
1.3 APPLICABLE DOCUMENTS	1-2
1.4 SYSTEM OVERVIEW	1-3
1.4.1 Custom Applications	1-4
1.5 SYSTEM DESCRIPTION	1-5
1.5.1 SEAR II Event Recorder Unit, A80273	1-5
1.5.2 SEAR II Event Recorder Expansion Modules.....	1-9
1.6 SPECIFICATIONS.....	1-17
1.6.1 Power Requirements	1-17
1.6.2 Echelon® LonTalk™ Interface	1-18
1.6.3 Monitored Inputs.....	1-18
1.6.4 Controlled Outputs	1-19
1.6.5 Visual Indicators.....	1-20
1.6.6 Switches	1-20
1.6.7 External Interface Connectors	1-21
1.6.8 Message Protocols.....	1-22
1.6.9 Mechanical.....	1-22
1.6.10 Environmental.....	1-23
1.6.11 Reliability/Protection.....	1-24
1.6.12 Events/Alarms.....	1-24
1.7 ORDERING INFORMATION.....	1-24
1.8 TECHNICAL SUPPORT.....	1-24
2.0 INSTALLATION.....	2-1
2.1 PHYSICAL INSTALLATION	2-1
2.1.1 Mounting the Units.....	2-1
2.1.2 Ventilation Requirements.....	2-1
2.1.3 Surge Protection	2-2
2.1.4 Power Interface/Requirements	2-2
2.1.5 Echelon LAN Interface.....	2-3
2.1.6 Radio and Modem Interfaces	2-5
2.1.7 Diagnostic Terminal and Printer Interfaces	2-7
2.1.8 Digital Input Interface	2-8
2.1.9 Analog Input and Relay Interface	2-9
2.1.10 Connector Wiring Procedure	2-9
2.1.11 Wiring Applications.....	2-11
2.1.12 Initial Power-Up and Internal Battery Backup.....	2-16
3.0 OPERATION.....	3-1
3.1 MENU MAPS.....	3-2

3.2	POWERING UP THE SYSTEM	3-4
3.2.1	The Terminal Boot Screen.....	3-4
3.2.2	The LUI Boot Display	3-5
3.2.3	Upgrading the Executive Software	3-6
3.3	USING THE TERMINAL INTERFACE.....	3-7
3.3.1	Terminal Interface Main Menu Options	3-8
3.3.2	Navigating Terminal Screen Menus	3-8
3.3.3	Terminal Data Entry	3-9
3.4	USING THE LOCAL USER INTERFACE (LUI)	3-10
3.4.1	LUI Top Level.....	3-10
3.4.2	Navigating LUI Menus.....	3-11
3.4.3	LUI Main Menu Options.....	3-11
3.4.4	LUI Data Entry	3-12
3.4.5	LUI Quick Keys.....	3-13
3.5	SETTING THE DATE & TIME.....	3-13
3.6	VIEWING REPORTS	3-14
3.6.1	Event Storage.....	3-15
3.7	CONFIGURATION DATA	3-16
3.7.1	Site Information	3-17
3.7.2	Communication Settings.....	3-17
3.7.3	Serial Ports	3-22
3.7.4	Digital Inputs	3-23
3.7.5	Battery Inputs	3-25
3.7.6	Relay Outputs	3-27
3.7.7	Test LEDs	3-28
3.7.8	Indicator LEDs	3-29
3.7.9	LED Mode.....	3-30
3.7.10	Expansion Modules.....	3-30
3.7.11	Restoring Default Configuration Settings	3-32
3.8	MONITORING SYSTEM I/O.....	3-39
3.8.1	Monitoring Onboard I/O on the Terminal	3-40
3.8.2	Monitoring Onboard LEDs on the Terminal.....	3-40
3.8.3	Monitoring Digital Inputs on the LUI	3-42
3.8.4	Monitoring Battery Inputs on the LUI.....	3-43
3.8.5	Monitoring Relay Outputs on the LUI.....	3-43
3.8.6	Monitoring Network I/O on the LUI.....	3-44
3.8.7	Monitoring Field Communications on the LUI.....	3-44
3.9	INCIDENT STORAGE	3-44
3.10	REPAIR HISTORY	3-45
3.11	PASSTHROUGH MODE.....	3-47
3.12	EVENT STREAM.....	3-47
3.13	CHANGING PASSWORDS	3-48
3.14	VERSIONS.....	3-49
3.15	APPLICATIONS	3-49
3.16	TESTS	3-49
Appendix A	INSTALLING FERRITE BEAD EMI FILTERS ON SEAR II CABLES.....	A-1

List Of Tables

Table 1-1. Reference Documents.....	1-2
Table 1-2. SEAR II A80273 - Control, Indicator, and Connector Functions.....	1-7
Table 1-3. Analog and Digital I/O Unit, A80258 - Indicator and Connector Functions.....	1-11
Table 1-4. Analog Unit, A80261 - Indicator and Connector Functions.....	1-13
Table 1-5. Hardware Configuration Options for Analog/Modem Assembly, A80260.....	1-16
Table 2-1. Power & Echelon Interface Connector Pinouts.....	2-2
Table 2-2. GCP/MS LAN Interface Options.....	2-3
Table 2-3. SEAR II A80273 COMM Interface Connector (J2) Pinouts.....	2-6
Table 2-4. SEAR II A80273 AUX Interface Connector (J3) Pinouts.....	2-6
Table 2-5. SEAR II A80273 USER Interface Connector (J4) Pinouts (RS232).....	2-7
Table 2-6. SEAR II Digital Input Interface Connector (J5, J6, J7) Pinouts.....	2-8
Table 2-7. SEAR II Analog Input/Relay Output Interface Connector (J8) Pinouts.....	2-9
Table 3-1. Communications Settings.....	3-17
Table 3-2. Collector Settings.....	3-18
Table 3-3. Node Settings.....	3-19
Table 3-4. CDS-902x Settings.....	3-20
Table 3-5. Bullhorn/Modbus Settings.....	3-20
Table 3-6. Serial Port Settings.....	3-22
Table 3-7. Digital Input Settings.....	3-24
Table 3-8. Battery Input Settings.....	3-26
Table 3-9. Relay Output Settings.....	3-27
Table 3-10. Test LED Settings.....	3-28
Table 3-11. Indicator LED Settings.....	3-29
Table 3-12. Module Settings.....	3-31
Table 3-13. Default Configuration Settings.....	3-33
Table 3-14. Repair History Entries.....	3-46

List Of Figures

Figure 1-1. Possible Event Analyzer/Recorder System Configuration	1-4
Figure 1-2. SEAR II A80273 - Keypad, Display, and Connector Locations	1-6
Figure 1-3. Analog and Digital I/O Unit, A80258 - Indicator and Connector Locations	1-10
Figure 1-4. Analog Unit, A80261 - Indicator and Connector Locations	1-12
Figure 1-5. SDIM / SDIMFE Data Flow to SEAR II	1-14
Figure 1-6. Analog/Modem Assembly A80260-06	1-16
Figure 2-1. Typical SEAR II LAN Connections	2-4
Figure 2-2. Typical DC Power/Echelon Connector Wire Insertion	2-10
Figure 2-3. Typical Digital Input Wiring	2-12
Figure 2-4. Battery Monitoring Input Wiring	2-13
Figure 2-5. Typical Relay Output Wiring	2-14
Figure 2-6. Serial Communications Wiring Arrangement	2-15
Figure 3-1 Terminal Interface Menu Map	3-2
Figure 3-2 Local User Interface (LUI) Menu Map	3-3
Figure 3-3. SEAR II Terminal Emulation Boot Screen	3-4
Figure 3-4. The Boot Monitor Choice Prompt.	3-6
Figure 3-5. SEAR II Terminal Interface Main Menu	3-7
Figure 3-6. LUI Keypad and Display	3-10
Figure 3-7. Collector-Node SEAR-II Field Layout	3-21

NOTES, CAUTIONS, AND WARNINGS

Throughout this manual, notes, cautions, and warnings are frequently used to direct the reader's attention to specific information. Use of the three terms is defined as follows:

WARNING

WARNING

INDICATES A POTENTIALLY HAZARDOUS SITUATION WHICH, IF NOT AVOIDED, COULD RESULT IN DEATH OR SERIOUS INJURY. WARNINGS ALWAYS TAKE PRECEDENCE OVER NOTES, CAUTIONS, AND ALL OTHER INFORMATION.

CAUTION

CAUTION

REFERS TO PROPER PROCEDURES OR PRACTICES WHICH IF NOT STRICTLY OBSERVED, COULD RESULT IN A POTENTIALLY HAZARDOUS SITUATION AND/OR POSSIBLE DAMAGE TO EQUIPMENT. CAUTIONS TAKE PRECEDENCE OVER NOTES AND ALL OTHER INFORMATION, EXCEPT WARNINGS.

NOTE

NOTE

Generally used to highlight certain information relating to the topic under discussion.

If there are any questions, contact Siemens Mobility, Inc. Application Engineering

ELECTROSTATIC DISCHARGE (ESD) PRECAUTIONS

Static electricity can damage electronic circuitry, particularly low voltage components such as the integrated circuits commonly used throughout the electronics industry. Therefore, procedures have been adopted industry-wide which make it possible to avoid the sometimes invisible damage caused by electrostatic discharge (ESD) during the handling, shipping, and storage of electronic modules and components. Siemens Mobility, Inc. has instituted these practices at its manufacturing facility and encourages its customers to adopt them as well to lessen the likelihood of equipment damage in the field due to ESD. Some of the basic protective practices include the following:

- Ground yourself before touching card cages, assemblies, modules, or components.
- Remove power from card cages and assemblies before removing or installing modules.
- Remove circuit boards (modules) from card cages by the ejector lever only. If an ejector lever is not provided, grasp the edge of the circuit board but avoid touching circuit traces or components.
- Handle circuit boards by the edges only.
- Never physically touch circuit board or connector contact fingers or allow these fingers to come in contact with an insulator (e.g., plastic, rubber, etc.).
- When not in use, place circuit boards in approved static-shielding bags, contact fingers first. Remove circuit boards from static-shielding bags by grasping the ejector lever or the edge of the board only. Each bag should include a caution label on the outside indicating static-sensitive contents.
- Cover workbench surfaces used for repair of electronic equipment with static dissipative workbench matting.
- Use integrated circuit extractor/insertion tools designed to remove and install electrostatic-sensitive integrated circuit devices such as PROM's (OK Industries, Inc., Model EX-2 Extractor and Model MOS-40 Inserter (or equivalent) are highly recommended).
- Utilize only anti-static cushioning material in equipment shipping and storage containers.

For information concerning ESD material applications, please contact the Technical Support Staff at 1-800-793-7233. ESD Awareness Classes and additional ESD product information are also available through the Technical Support Staff.

SECTION I

INTRODUCTION

1.0 INTRODUCTION

1.1 GENERAL

The second generation Event Recorder (SEAR II) part number A80273, is a non-vital stand-alone system designed to provide continuous real-time general purpose status monitoring and event recording for a wide range of functions associated with railroad wayside and grade crossing installations.



WARNING

THE SEAR II IS A NON-VITAL PRODUCT. CAUTION MUST BE TAKEN WHEN INTERFACING THE SEAR II TO ANY VITAL SIGNAL OR CROSSING EQUIPMENT AS THE SEAR II CAN NOT BE USED TO PERFORM, EITHER DIRECTLY OR INDIRECTLY, ANY VITAL FUNCTIONS. ENSURE THE SEAR II IS INSTALLED PER MANUFACTURER'S INSTRUCTIONS, AND/OR ALL EQUIPMENT INTERCONNECTIONS ARE IN COMPLIANCE WITH RAILROAD PROCEDURES AND SPECIFICATIONS.

1.2 SCOPE

This manual serves as the installation and operation guide for the SEAR II. Configuration and programming of the SEAR II are described in section III of this manual - *Operation*.

1.3 APPLICABLE DOCUMENTS

Table 1-1. Reference Documents

Component	Manual Title	Document Number
SEAR II Event Analyzer Recorder, A80273	Installation and Operation Manual	SIG 00-02-07
Event Recorders: <ul style="list-style-type: none"> • A80273 SEAR II • A80311 Argus • A80410 SEAR III 	NS Backhaul Service Manual	SIG-00-20-06
Ground Fault Tester, A80297	User Guide	SIG-00-03-05-003
iLOD, A80271	User Guide	SIG-00-03-05-005
Mighty Modem, 53413	Instruction and Installation Manual	COM-00-97-09
Mini Trackside Sensor Package	User Guide	SIG-00-03-05-001
S3/Link Spread Spectrum Radio, 53308	Instruction and Installation Manual	COM-00-97-21 or COM-00-94-04
Scalable Digital Input Module (SDIM), A80293, A80295	User Guide	SIG-00-03-05-004
VHF Communicator, A80276	User Guide	SIG-00-03-05-002
Wayside Communications Controller (WCC)/Field Protocol Device (FPD) for ATCS Radio Code Line Systems	Installation and Operation Manual	COM-00-99-05
Wayside Communications Package CPU II, A53105	Installation and Operation Manual	COM-00-97-10
Wayside Communications Package, A53411	Installation Manual	COM-00-98-01

1.4 SYSTEM OVERVIEW

The SEAR II Event Recorder was designed to provide full monitoring, recording and reporting functions for most standard crossing configurations without the need for any other modules (except for light-out detectors, or other optional applicable devices such as bell and gate tip Level sensors, ground fault detectors, etc.) The basic SEAR II system configuration (standalone recorder with no expansion modules) can monitor up to 23 separate input functions (18 digital inputs, 3 analog inputs, internal temperature and internal battery sensor functions) 2 internal non-vital relays with Heel and Front dry contacts are also provided. All input, output, and recorder functions are user-programmable through various user interfaces.

SEAR II configurations can be modularly expanded through the use of various intelligent modules that perform input functions, output functions, I/O functions, communications functions, etc. These modules connect to the SEAR II recorder and communicate via the Echelon® LonTalk™ LAN. Refer to Figure 1-1 for some types of equipment available now or in the future using the Echelon LonTalk interface.

The SEAR II front panel contains 16 red LED indicators, 8 tri-color LED indicators, a 2-line X 20-character Vacuum Fluorescent Display (VFD) and a keypad matrix consisting of 25 embossed keys with tactile feedback. The Unit is comprised of the system microprocessor, the event memory and all the I/O circuitry. The memory capacity is expandable from 150,000 stored events (standard memory) to 350,000 stored events (expanded memory). Recorded information and monitored states can be accessed via the local display/keypad user interface, using a local laptop computer, serial printer, or remotely via radio or telephone dial-up modem, through connectors provided on the front panel.

For Unit configuration and logic programming information for the SEAR II system, or for reviewing the Event Log, refer to section III of this manual – *Operation*.

The analog and digital I/O circuits on the SEAR II and expansion modules provide the interface for all monitored inputs via connectors accessible from their front panels. The analog and digital I/O expansion modules interface to the SEAR II via an Echelon twisted pair bus (see Figure 1-1). Radio and telephone modem interfaces use the COMM and AUX serial ports (J2 and J3) on the SEAR II front panel, and a serial printer or computer can be connected to the USER serial port (J4).

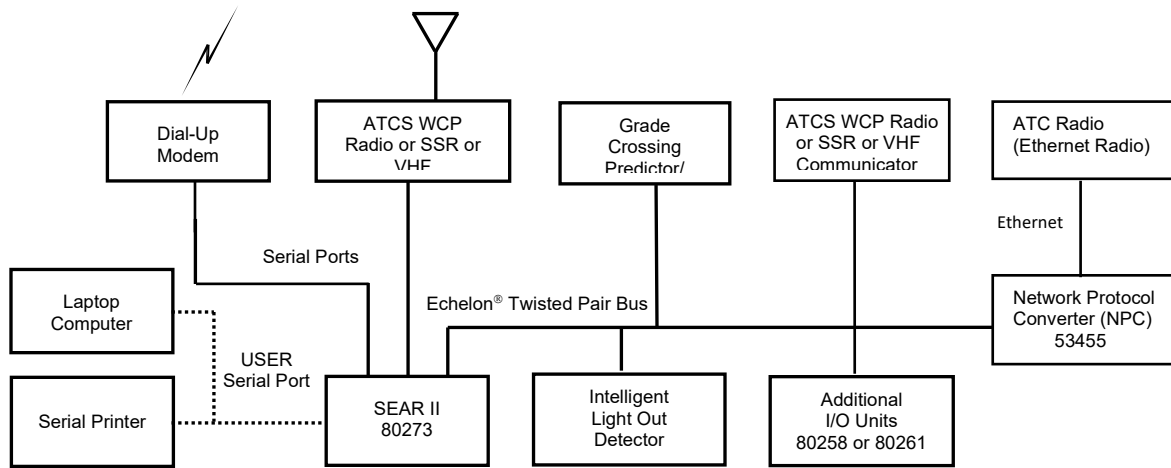

* With Optional Interface Card

Figure 1-1. Possible Event Analyzer/Recorder System Configuration

A single device such as a lamp or a switch (up to 30 amperes maximum, peak) can be monitored by connecting an iLOD - Intelligent Light Out Detector module to the SEAR II via the Echelon LAN.

Communications with a variety of technologies is supported via the system-wide Echelon bus or the RS232/RS422 (COMM, AUX and USER) serial ports. These peripherals include ATCS MCP radio, spread-spectrum radio, and telephone dial-up modem. Protocols include ATCS Specification 200 (per AREMA recommendations), and ASCII. Additional protocols can also be accommodated (contact Siemens Rail Automation Applications Engineering at 1-800-793-SAFE).

The SEAR II uses a unique programming language that allows the user complete customization and command over the recorder, controlling how it monitors its I/O points and how it detects, processes and records alarms and events. This user program is created using any PC-based text editor, such as WordPad. Once the program is completed, the text file is downloaded into the SEAR II where it is stored in non-volatile (FLASH) memory. The text program is then automatically compiled into an efficient, intermediate language module that is interpreted by a fast execution engine contained in the SEAR II executive. This approach gives the user all the power of a high-level programming language while maximizing execution speed once the application program is downloaded into the SEAR II.

The SEAR II is fully configurable for each installation site. The configuration can be done via the local user interface (LUI display/keypad) or using a Laptop or PC running any standard terminal emulation program such as HyperTerminal. This provides a user-friendly platform for site configuration, without the need for special software

1.4.1 Custom Applications

With the options of using “Crossing Description Language” (CDL) and/or ladder logic, various I/O expansion modules, and communications options, you can use the SEAR II for just about any non-vital application.

1.5 SYSTEM DESCRIPTION

1.5.1 SEAR II Event Recorder Unit, A80273

The SEAR II, part number A80273, is at the heart of any event recorder configuration. It contains the system microprocessor, real-time clock, event and program memory, display, keypad, digital inputs, battery monitor inputs, relay outputs, red Indicator LEDs, tri-color Test LEDs, beeper and communications interfaces. All controls, indicators, and connectors are accessible from the front panel of the unit.

To accommodate virtually any recording/monitoring application, the SEAR II includes two RS232/RS422 ports for radio or modem, and an RS232 port for local laptop computer or standard serial printer connections. A 40-character (2 lines of 20 characters each) high-visibility, vacuum fluorescent alphanumeric display, 25-key embossed keypad with tactile feedback, 24 LEDs (16 red Indicator and 8 tri-color Test) and a beeper complete the local user interface.

Label slots are provided in the front panel adjacent to each LED indicator. The tri-color Test LEDs (red/orange/green) are used to convey more complex information such as the status of user tests, which can include results such as "Passed", "Failed", "Passed After Failure", "Not Executed", etc.

In complex event recorder configurations, containing expansion modules, all data monitored in the system are routed to the SEAR II where it is processed, stored, and when applicable, can initiate appropriate action in response to preprogrammed criteria. A SEAR II can also function as a communications hub to enable multiple recorder units to use a single dial-up modem/radio connection.

The SEAR II acts as host and communicates with other nodes on the Echelon LAN via a twisted pair cable. Devices the SEAR II may be connected to by way of the LAN include intelligent Light Out Detector (iLOD) Units, Analog and Digital I/O Units, Analog Input Units, Grade Crossing Predictors (GCPs) and Motion Sensors (refer to Figure 1-1).

The SEAR II is designed for wall, shelf, or rack mounting (19-inch standard, or 23-inch with extension panels) and provides front panel access to all controls, indicators, and connectors for ease of installation and user interface. Each of the controls, indicators, and connectors is identified in Figure 1-2 and described in Table 1-2.

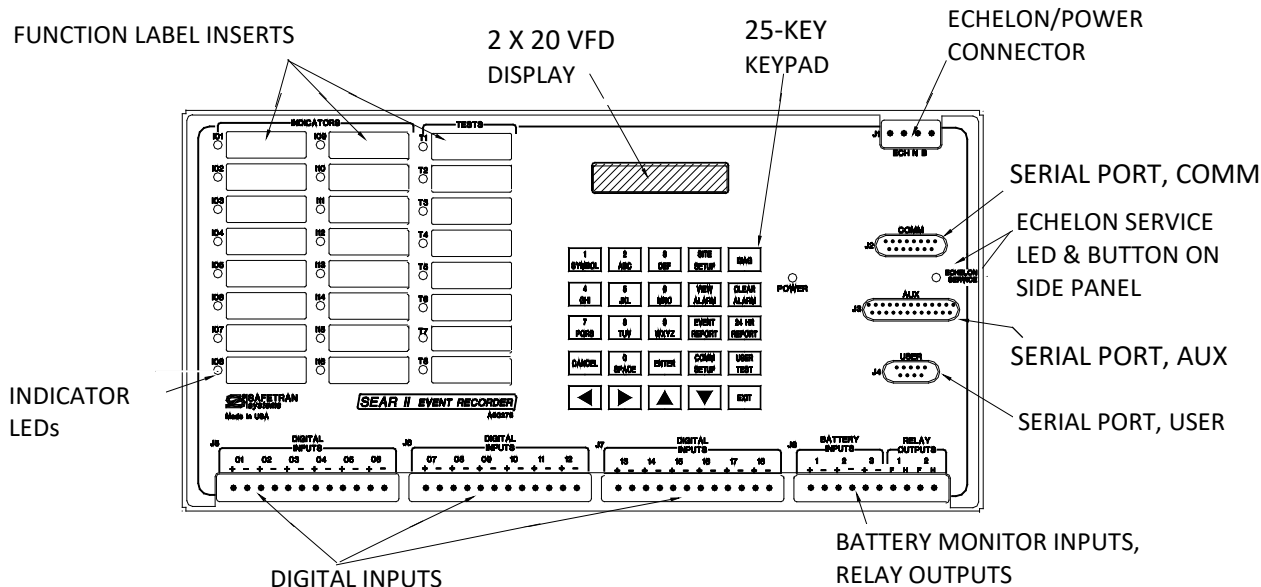

Figure 1-2. SEAR II A80273 - Keypad, Display, and Connector Locations

Table 1-2. SEAR II A80273 - Control, Indicator, and Connector Functions

PHYSICAL DESCRIPTION	FRONT-PANEL NOMENCLATURE	FUNCTION
2-line X 20-character VFD display	(none)	Displays alarms/events and site configuration data, system & I/O status
Embossed keypad with tactile/audible feedback	25 keys with individual function text	Use to navigate through menu system and for entering, viewing and manipulating event and configuration data (refer to Section II – <i>Installation</i>)
DB15 and DB25 female connectors, RS232/RS422 standard interface	COMM, AUX J2, J3	Provide interface for radio, telephone dial-up modems or other communications devices
DB9 female connector, RS232 standard interface	USER J4	Provides interface for a local serial printer or computer
4-pin male connector with supplied matching female connector	ECH N B J1	Provides interface to Echelon twisted pair bus (ECH) and power source (B and N)
Activity indicator LEDs (programmable)	INDICATORS I01-I16	Provide activity indication for user-programmable events/alarms
Test indicator LEDs	TESTS T1-T8	Provide result indication of user tests or indication of any user event/alarm or I/O status
12-pin male connectors with supplied matching female connectors	DIGITAL INPUTS J5 (1-6 + and –) J6 (7-12 + and –) J7 (13-18 + and –)	Each connector provides six opto-isolated digital inputs (one positive and one negative terminal per input) used typically for monitoring relay or switch contact closures (see paragraph 1.4.1.5, <i>Digital Inputs</i>).
10-pin male connector with supplied matching female connector	BATTERY INPUTS / RELAY OUTPUTS J8 (1-3 + and –) batteries (1-2 H and F) relays	The connector provides three isolated battery monitor inputs (one positive and one negative terminal per input) used typically for monitoring DC batteries (refer to paragraph 1.4.1.6, <i>Battery Monitor Inputs</i>). The connector also provides two isolated-contact relay outputs (one heel and one front terminal per output) for non-vital applications (typically used to control relays and outside indicator lamps.) Refer to paragraph 1.4.1.7, <i>Relay Outputs</i> .
Function label areas	(none)	Permit identifying label to be written next to each activity indicator LED/test LED
Echelon service LED and push-button switch	ECHELON SERVICE	The LED will flash until the unit is initialized. The push button is not used in this application.

1.5.1.1 Microprocessor

The SEAR II contains a microprocessor that controls all functions of the system. The executive software, configuration, and user program are all downloaded into flash memory. The SEAR II is programmed using a PC running standard Windows® applications such as terminal emulation programs (HyperTerminal, etc.) and text editors (WordPad, etc.) The SEAR II can also be completely configured from the local user interface on the front panel, without the need of a computer.

1.5.1.2 Real Time Clock

The SEAR II contains a real-time clock. The time and date can be set in the unit from the front panel or from a computer connected to the USER port of the unit. The time and date is used to timestamp events in the Event Log. In the event of a power failure, the internal back-up battery will accurately maintain the time and date. The real-time clock automatically adjusts for leap years and the software makes provision for automatic daylight savings adjustments under user control.

1.5.1.3 Event Memory

The Processor/Display Unit uses battery-backed SRAM (Static Random Access Memory) for event storage. The event memory capacity in the standard SEAR II configuration is 150,000 events. With the memory expansion option, the memory capacity is 350,000 events.

1.5.1.4 Internal Battery

The internal lithium battery maintains power to the SRAMs and real-time clock when power to the unit is off. If the SEAR II is powered off for a continuous period of time, to ensure data retention Siemens Rail Automation recommends replacing the battery after every 2 months of inactivity, as specified in Siemens Product Information Bulletin # PIB 2-14. The SEAR II uses a 3.6 V AA-size lithium battery that is readily available at many retail outlets.

The SEAR II comes with two battery holders. Only one holder is loaded with a battery. Battery replacement can be performed with or without power applied to the SEAR II.



CAUTION

TO PREVENT LOSS OF POWER TO THE MEMORY AND REAL-TIME CLOCK DURING BATTERY REPLACEMENT WHERE THE UNIT IS NOT UNDER POWER, A NEW BATTERY SHOULD BE INSERTED INTO THE EMPTY HOLDER BEFORE REMOVING THE OLD BATTERY.

When the internal battery voltage drops below a pre-determined level required for reliable, long-term operation, a low-battery warning alarm will be issued and an event will be recorded. The user will be prompted to replace the battery as soon as possible. However, for increased reliability Siemens Rail Automation recommends replacing the internal battery after every two years of normal operation, rather than waiting for a low-battery warning alarm. Refer to Siemens Product Information Bulletin # PIB 2-14.

SEAR II units are shipped from the factory with the internal lithium battery electronically disconnected from the circuit. The battery will be automatically connected when the unit is first powered up in the field. This feature is called “battery freshness seal” and is provided to maximize battery life.

Because of the battery freshness seal feature, the internal memory and the real-time clock will contain unknown data when the unit is powered up for the first time in the field. Therefore, Time/Date adjustments should be performed immediately following the initial power-up sequence in the field.

1.5.1.5 Digital Inputs

The SEAR II event recorder offers 18 independently isolated digital inputs. These inputs can monitor signals in the range of 0-120V AC/DC. Digital inputs have the following states: *on*, *off*, *toggleing* and *unknown* (*unknown* reflects a special condition when inputs on expansion modules have not yet been initialized).

Siemens Rail Automation offers additional modules that can extend the SEAR II’s digital input capability. These interface with the SEAR II over the Echelon interface. They include the Analog and Digital I/O Expansion Unit, and the SDIM and SDIMFE expansion unit. (see subsection 1.5.2).

1.5.1.6 Battery Monitor Inputs

The SEAR II event recorder offers three independently isolated battery monitor analog inputs. These inputs can monitor signals in the range of 0-36VDC.

1.5.1.7 Relay Outputs

The SEAR II event recorder offers two sets of independently isolated *front/heel* contacts of internal non-vital output relays. These contacts are rated for 5A at 30VDC or 120VAC.

1.5.2 SEAR II Event Recorder Expansion Modules

The SEAR II Event Recorder configuration can be modularly expanded through the use of optional intelligent I/O modules on the Echelon LAN and other equipment such as communications devices, peripherals, etc. The following paragraphs describe the available Siemens Rail Automation equipment that can be used to expand a SEAR II event recording system.

1.5.2.1 Analog and Digital I/O Unit, A80258

The Analog and Digital I/O Unit, part number A80258, can monitor up to 30 separate functions (24 external digital inputs, 4 external analog inputs, and internal temperature and internal battery sensor functions) with all input, output, and recorder functions user-programmable. In addition to 24 digital inputs and 4 digital outputs, each A80258 unit can accommodate up to 4 analog inputs including high and low voltage sensing

The A80258-01 contains the Analog Input PC board (A80259) and the Digital I/O PC board (A80254). A hardware option (A80258-02) provides for exclusion of the analog function (which can be provided separately by the A80261 unit). The A80258 unit is designed for wall, shelf, or rack mounting (19-inch standard, or 23-inch with extension panels) and provides front panel access to all indicators and connectors for ease of installation. Each of the indicators and connectors is identified in Figure 1-3 and described in Table 1-3.

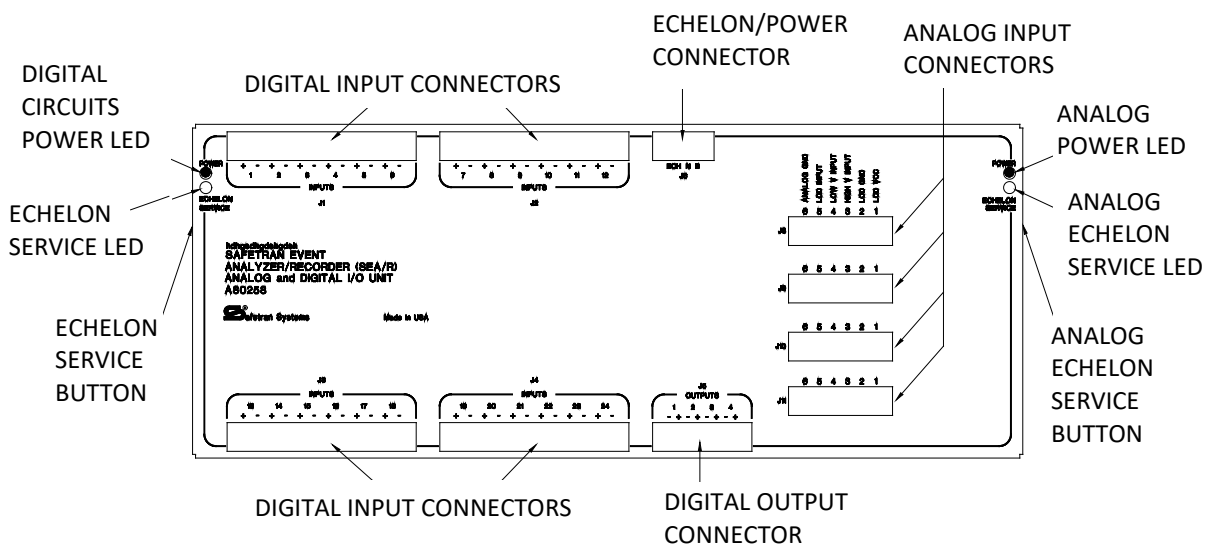

Figure 1-3. Analog and Digital I/O Unit, A80258 - Indicator and Connector Locations

Table 1-3. Analog and Digital I/O Unit, A80258 - Indicator and Connector Functions

PHYSICAL DESCRIPTION	FRONT-PANEL NOMENCLATURE	FUNCTION
12-pin male connectors with supplied matching female connectors	INPUTS J1 (1-6 + and –) J2 (7-12 + and –) J3 (13-18 + and –) J4 (19-24 + and –)	Each connector provides six opto-isolated digital inputs (one positive and one negative terminal per input) used typically for monitoring relay or switch contact closures (refer to paragraph 1.5.3, <i>Monitored Inputs</i>).
8-pin male connector with supplied matching female connector	OUTPUTS (NON-VITAL) J5 (1-4 + and –)	Connector provides four digital outputs (one positive and one negative terminal per output) for non-vital applications only (typically used as relay drive circuits). Refer to paragraph 1.5.4, <i>Controlled Outputs</i> .
4-pin male connector with supplied matching female connector	ECH N B J6	Provides interface to Echelon twisted pair bus (ECH) and power source (B and N) - power and Echelon connections provided to both digital and analog circuits internally
6-pin male connectors with supplied matching female connectors	J8, J9, J10, J11 1 LOD VCC 2 LOD GND 3 HI V INPUT 4 LOW V INPUT 5 LOD INPUT 6 ANALOG GND	Analog inputs - each connector provides an analog ground, high and low voltage sensing inputs, and connections for the Light Out Detector Assembly (this light out detection scheme has been superseded by the iLOD module. Refer to paragraph 1.5.3, <i>Monitored Inputs</i>).
Power LED	POWER	Power indicator lights when unit is connected to active power source
Echelon service push-button switches and LEDs (separate switch and LED for digital and analog circuits)	ECHELON SERVICE	When analog or digital push button is pressed, SEAR II sends device configuration data to the analog or digital card in A80258 unit. Each Echelon LED on A80258 lights when its push button is pressed to verify switch contact

1.5.2.2 Analog Unit, A80261

The Analog Unit, part number A80261, can monitor four analog inputs including high and low voltage sensing

The A80261 unit is designed for wall, shelf, or rack mounting (special mounting panels required for 19-inch or 23-inch racks), and is physically small enough to mount up to two A80261 units or one A80261 unit together with one 53413 unit (modem) on the 19-inch panel, and up to three A80261 units or two A80261 units together with one 53413 unit (modem) on the 23-inch panel.

The A80261 unit contains the Analog Input PC board (A80259) and provides front access to all indicators and connectors for ease of installation. Each of the controls and connectors is identified in Figure 1-4 and described in Table 1-4.

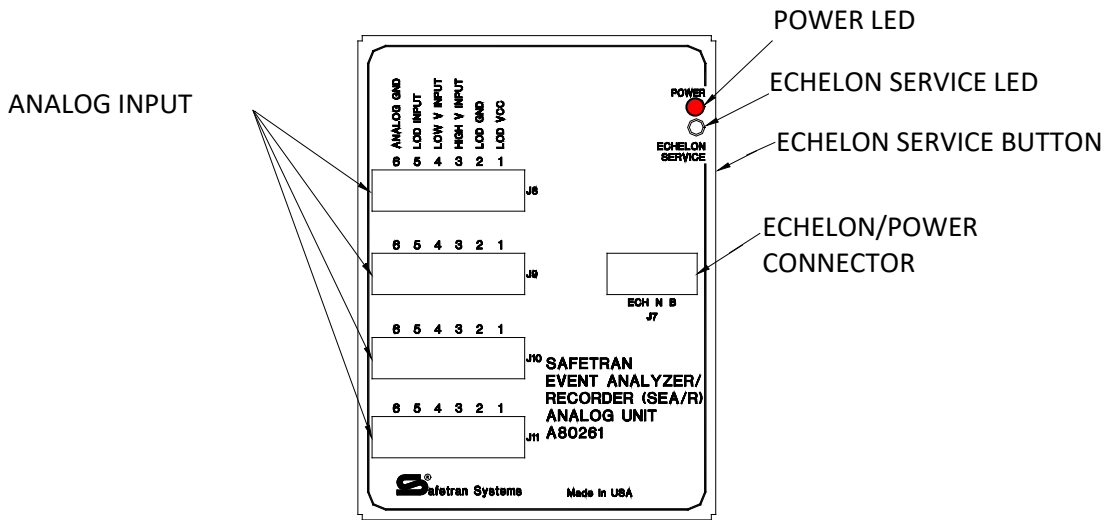

802501-4
08-11-98

Figure 1-4. Analog Unit, A80261 - Indicator and Connector Locations

Table 1-4. Analog Unit, A80261 - Indicator and Connector Functions

PHYSICAL DESCRIPTION	FRONT-PANEL NOMENCLATURE	FUNCTION
6-pin male connectors with supplied matching female connectors	J8, J9, J10, J11 1 LOD VCC 2 LOD GND 3 HI V INPUT 4 LOW V INPUT 5 LOD INPUT 6 ANALOG GND	Analog inputs - each connector provides an analog ground, high and low voltage sensing inputs, and connections for the Light Out Detector Assembly (this light out detection scheme has been superseded by the iLOD module. Refer to paragraph 1.5.3, <i>Monitored Inputs</i>).
Power LED	POWER	Power indicator lights when unit is connected to active power source
4-pin male connector with supplied matching female connector	ECH N B J7	Provides interface to Echelon twisted pair bus (ECH) and power source (B and N)
Echelon service push-button switch and LED	ECHELON SERVICE	When the Echelon Service push button is pressed, Processor/Display Unit sends device configuration data to the analog card in the A80261 unit. The Echelon LED on the A80261 lights when its push button is pressed to verify switch contact

1.5.2.3 SDIM (A80293) and SDIMFE (A80295) Digital I/O Expansion Modules

The SDIM is ideal for applications where a large number of digital inputs need to be monitored, such as control points and yards. Because of the scalability of its digital input arrangement, the SDIM provides a cost-effective solution for applications requiring varying numbers of digital inputs.

The main SDIM unit can handle 24 digital inputs as a standalone unit. Through the addition of the low-cost, low profile SDIMFE, the monitoring capabilities of the SDIM can grow modularly, in 24 digital-input steps. If the application calls for more inputs to be monitored, one or more SDIMFE modules can be added to the SDIM configuration, allowing you to choose the best way to handle the number of inputs to be monitored: 24, 48, 72, 96 or 120. Because the bulk of the interface is located in the main SDIM module, increasing the number of inputs beyond the initial 24 requires only a minor investment in hardware.

Another advantage of the modular architecture of the SDIM is that the low-profile SDIMFE modules do not have to be concentrated near the SDIM main unit. Instead, the SDIMFEs can be installed anywhere in the signal bungalow. This allows the connections to be made near the point or origin of the signals being monitored and reduces the overall wiring inside the bungalow. The connection between SDIM and SDIMFE modules is simple and clean, using CAT5e straight patch cables, the same type of cabling used to connect computers to an Ethernet network.

1.5.2.4 Dial-up Modem Link

Inputs, outputs, diagnostics, and the event log of the SEAR II may be accessed from remote locations by incorporating telephone dial-up modems. If a modem is required, the recommended unit is our Mighty Modem, part number 53413, a DC-powered modem suitable for remote sites. For information on the Mighty Modem, refer to manual: MIGHTY MODEM - Installation & Maintenance (Document # COM-00-97-09).

1.5.2.5 Radio Link

Inputs, outputs, diagnostics, and the event log of the SEAR II may be accessed from remote locations by incorporating a radio link. For example, a Wayside Communications Package (WCP) radio might be used to communicate to the office through its Base Communications Package (BCP) radio. This interface from the SEAR II would use the RS232/RS422 port.

A radio link could use our Spread Spectrum Radio (SSR), which would also interface from the SEAR II by using the RS232/RS422 port. For information on the SSR, refer to manual: S3/LINK SPREAD SPECTRUM RADIO - Instruction & Installation Manual (Document #'s COM-00-97-21 or COM-00-94-04).

1.5.2.6 Grade Crossing Predictor/Motion Sensor

Grade Crossing Predictors and Motion Sensors can use the SEAR II for logging their warning times, train speeds, and diagnostic codes. In order to do so, the GCPs or Motion Sensors must be connected to the SEAR II system Echelon LAN and installed as nodes (refer to Section III, paragraph 3.8.1.2, *Install Node*) during the system setup.

In order to communicate over the LAN, each GCP or Motion Sensor must have an optional external LAN interface circuit card installed (refer to Table 2-2 in Section II, paragraph 2.1.5, *Echelon LAN Interface*, for a list of GCP/MS Units and their options for the network interface, or refer to the GCP or Motion Sensor manual). In addition, the LAN twisted pair cable requires a GCP-To-Network Interface plug (part number A80063) to be connected to J1 (the RECORDER port) of each GCP or Motion Sensor to be connected. This plug provides a screw-down terminal connector for the twisted pair cable (refer to Section II, paragraph 2.1.5, *Echelon LAN Interface*, for more information on the GCP-To-Network Interface plug).

1.5.2.7 Analog/Modem Assembly, A80260

The Analog/Modem Assembly, part number A80260, is available with several options for clustering multiple Analog Units, A80261 and a Mighty Modem, 53413, if required, in 19-inch or 23-inch rack installations. Figure 1-6 shows the A80260-06 assembly, a 23-inch panel with two A80261 Analog Units and a 53413 modem installed. Table 1-5 presents a list of the hardware configuration options for the Analog/Modem Assembly, A80260.

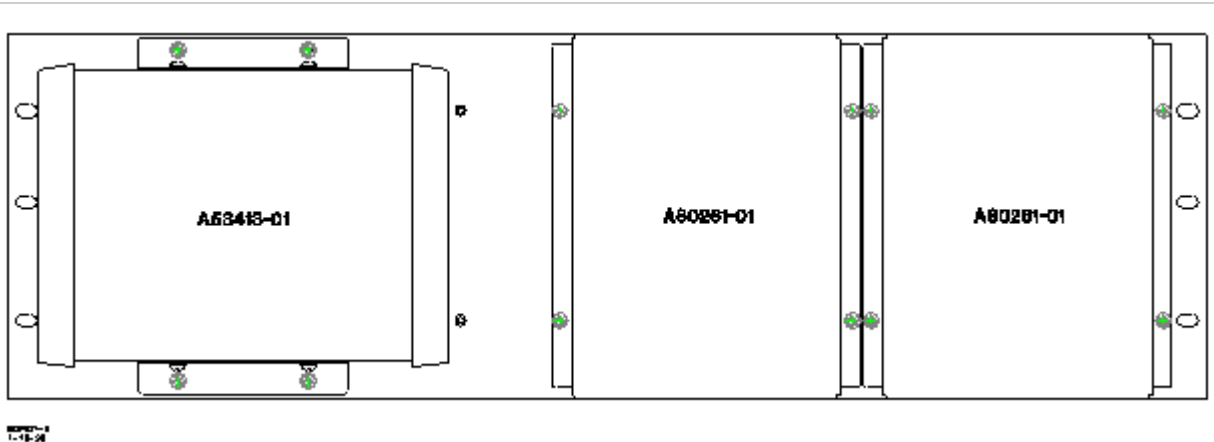

Figure 1-6. Analog/Modem Assembly A80260-06

Table 1-5. Hardware Configuration Options for Analog/Modem Assembly, A80260

DASH #	RACK SIZE	QUANTITY OF 80261 (ANALOG INPUT)	QUANTITY OF 53413 (MODEM)
-01	(reserved)	(reserved)	(reserved)
-02	23"	1	none
-03	23"	2	none
-04	23"	3	none
-05	23"	1	1
-06	23"	2	1
-07	19"	1	none
-08	19"	2	none
-09	19"	1	1
-0A	23"	none	1
-0B	19"	none	1

1.6 SPECIFICATIONS

This section includes specification data on the SEAR II, the Analog & Digital I/O expansion module, and the Analog I/O module.

For specifications data on the iLOD, SDIM, and other products refer to the Applicable Documents section (page 1-2).



CAUTION

FAILURE TO OBSERVE VOLTAGE AND ENVIRONMENTAL LIMITS AS SET FORTH IN THE FOLLOWING SPECIFICATIONS FOR THE EVENT ANALYZER/RECORDER CAN CAUSE DAMAGE TO THE EQUIPMENT.

1.6.1 Power Requirements

A80273 (SEAR II):

Input Voltage	9 - 30 VDC (customer supplied). Reverse polarity protection up to 16.5 VDC
Input Current	800 mA maximum 1200 mA maximum at startup
Isolation	2000 VRMS, 60 Hz, 60 Sec to chassis

A80258 (Analog & Digital I/O):

Input Voltage	9 - 30 VDC (customer supplied). Reverse polarity protection up to 16.5 VDC
Input Current	300 mA maximum 500 mA maximum at startup

A80261 (Analog Input):

Input Voltage	9 - 30 VDC (customer supplied). Reverse polarity protection up to 16.5 VDC
Input Current	150 mA maximum 200 mA maximum at startup

1.6.2 Echelon® LonTalk™ Interface

All Units:

Data Transfer Rate	1.25 Mbps
Transmission Medium	Level 4 (NEMA) twisted pair cable, shielded or unshielded, solid or stranded
Topology	Bus (direct daisy-chain)
Number of Nodes	No more than 8 (including any terminations used) in any 16-meter (53 feet) length of transmission cable, 16 maximum total per network segment
Termination	Normally not needed
Network Length	53 feet (16m) recommended maximum, 426 feet (130m) absolute maximum per network segment (with certain restrictions)



CAUTION

DUE TO THE NATURE OF THE ECHELON LAN INTERFACE, THE SEAR II AND ALL DEVICES CONNECTED TO THE LAN SHOULD BE CONTAINED ENTIRELY WITHIN THE SAME SIGNAL CASE OR BUNGALOW.

1.6.3 Monitored Inputs

A80273 (SEAR II):

Digital	18 opto-isolated digital inputs (up to 120 V AC/DC each) (6 to 120 VDC = energized, 0 to 0.8 VDC = de-energized)
---------	--



NOTE

The specified energized and de-energized DC voltage thresholds apply to the input circuit. The system software further samples and de-bounces the input circuit to determine the reported input state. The energized and de-energized voltage thresholds do not apply when monitoring AC voltage. The system may not reliably detect AC voltage below approximately 14.0 VRMS and specific de-bounce settings are required to accurately report AC input states.

Analog 3 isolated battery monitor analog inputs (0-36 VDC)

⚠ CAUTION

CAUTION

THE INPUT IMPEDANCE OF THE SEAR II DIGITAL INPUTS, UNDER FAILURE CONDITION, CAN BE AS LOW AS 10,000 OHMS. THE SEAR II DIGITAL INPUT SHOULD NOT BE USED IN APPLICATIONS WHERE INPUT IMPEDANCE ABOVE 10,000 OHMS COULD CONTRIBUTE TO AN UNSAFE CONDITION.

⚠ WARNING

WARNING

WHEN MONITORING VITAL RELAY COILS, BOTH SIDES OF EACH DIGITAL INPUT MUST BE WIRED DIRECTLY TO THE RELAY TERMINALS, AS SHOWN IN SECTION II, Figure 2-3.

A80258 (Analog & Digital I/O):

Digital	24 opto-isolated digital inputs (up to 36 VDC each) (+6 VDC to +36 VDC = energized, -20 VDC to +2.5 VDC = de-energized)
Analog	4 opto-isolated analog inputs (Low voltage 0-36 volts, Hi voltage 0-360 volts, AC or DC)

A80261 (Analog Input):

Analog	4 opto-isolated analog inputs (Low voltage 0-36 volts, Hi voltage 0-360 volts, AC or DC)
--------	--

1.6.4 Controlled Outputs

A80273 (SEAR II):

Relay Outputs	2 non-vital relays with isolated Front/Heel dry contacts. Contact rating: 5A @30 VDC/120 VAC
---------------	--

A80258 (Analog & Digital I/O):

Relay Drive	4 non-vital (opto-isolated, open collector), 250 mA each (short-circuit protected)
-------------	--

1.6.5 Visual Indicators

A80273 (SEAR II):

Display	2-line X 20-character alphanumeric VFD (high contrast vacuum fluorescent) display indicating date, time, site configuration, and event/alarm data for inputs & outputs. The front panel keypad allows selection of specific event/alarm data or site configuration information for viewing System & I/O status.
Light-emitting Diodes	INDICATORS (16 user definable and identifiable red LEDs) TESTS (8 user definable and identifiable tri-color LEDs – red, orange, green) ECHELON SERVICE (yellow LED, when flashing, indicates a non-configured device) POWER (green LED indicates power applied)

A80258 (Analog & Digital I/O):

Light-emitting Diodes	POWER (2 red LEDs, indicate power applied) ECHELON SERVICE (2 yellow LEDs for digital & analog boards, when flashing indicates a non-configured device)
-----------------------	--

A80261 (Analog Input):

Light-emitting Diodes	POWER (red LED, indicates power applied) ECHELON SERVICE (yellow LED for analog board, when flashing indicates a non-configured device)
-----------------------	--

1.6.6 Switches

A80273 (SEAR II):

Keypad	25-key, alphanumeric embossed overlay matrix with tactile/audible feedback (used to enter all data into the SEAR II unit)
Echelon Service	ECHELON SERVICE (The Neuron® Service push-button switch in the SEAR II is not used in standard applications.)

A80258, A80261 (Analog & Digital I/O, Analog Input)

Echelon Service ECHELON SERVICE (The Neuron® Service push-button switch in the analog and digital modules is used to install the node to the SEAR II)

1.6.7 External Interface Connectors**A80273** (SEAR II):

J1 ECH N B (keyed 4-pin male connector for Echelon LonTalk interface, and DC Power input and return to unit)

J2 COMM (keyed female DB-15 connector for RS232/RS422 serial interface to radio or telephone modem)

J3 AUX (keyed female DB-25 connector for RS232/RS422 serial interface to radio or telephone modem)

J4 USER (keyed female DB-9 connector for RS232 serial interface to printer or PC)

J5, J6, J7 DIGITAL INPUTS (3 keyed 12-pin male connectors for 6 digital input pairs each)

J8 BATTERY INPUTS / RELAY OUTPUTS (keyed 10-pin male connector for 3 battery monitor input pairs and 2 non-vital output relays with Front/Heel contacts)

A80258 (Analog & Digital I/O):

J1, J2, J3, J4 INPUTS (4 keyed 12-pin male connectors for 6 digital input pairs each)

J5 OUTPUTS (keyed 8-pin male connector for 4 non-vital digital output pairs, open collector)

J6 ECH N B (keyed 4-pin male connector for Echelon LonTalk interface, and DC Power input and return to unit)

J8, J9, J10, J11 LOD VCC, LOD GND, HI V INPUT, LOW V INPUT, LOD INPUT, ANALOG GND (4 keyed 6-pin male connectors, each containing high and low voltage sensing inputs referenced to ANALOG GND, Light Out Detector input signal referenced to LOD GND, and power to the Light Out Detector referenced to LOD GND)

A80261 (Analog Input):

J6	ECH N B (keyed 4-pin male connector for Echelon LonTalk interface, and DC Power input and return to the unit)
J8, J9, J10, J11	LOD VCC, LOD GND, HI V INPUT, LOW V INPUT, LOD INPUT, ANALOG GND (4 keyed 6-pin male connectors, each containing high and low voltage sensing inputs referenced to ANALOG GND, Light Out Detector input signal referenced to LOD GND, and power to the Light Out Detector referenced to LOD GND)

1.6.8 Message Protocols

All Units:

ATCS	Specification 200
ASCII	

1.6.9 Mechanical

A80273 (SEAR II):

Mounting	19-inch equipment rack, shelf, or wall
Width	19.0 inches (48.26 cm) overall including mounting flanges, 17.56 inches (44.60 cm) front panel
Height	8.7 inches (22.15 cm)
Depth	1.7 inches (4.27 cm)
Weight	5.8 Lbs (2.61 Kg) (approximate)

A80258 (Analog & Digital I/O):

Mounting	19-inch equipment rack, shelf, or wall (extensions for 23-inch racks also available)
Width	19.0 inches (48.26 cm) overall including mounting flanges, 17.5 inches (44.45 cm) front panel
Height	7.0 inches (17.78 cm)
Depth	1.8 inches (4.45 cm)
Weight	3.5 pounds (1.6 kg) (approximate)

A80261 (Analog Input):

Mounting	Wall, or shelf (panels for 19-inch and 23-inch racks also available)
Width	5.9 inches (15.0 cm) overall including mounting flanges, 5.60 inches (14.22 cm) horizontal mounting centers, 5.16 inches (14.0 cm) front panel
Height	7 inches (17.78 cm)
Depth	1.8 inches (4.45 cm)
Weight	1 pound (0.46 kg) (approximate)

1.6.10 Environmental**All Units:**

Temperature	-40°F to +160°F (-40°C to +71°C)
Humidity	95%, non-condensing

1.6.11 Reliability/Protection

A80273 (SEAR II):

Battery Backup	3 years (minimum) under typical operating conditions for stored event data and real-time clock
----------------	--

A80273, A80258, A80261 (SEAR II, Analog & Digital I/O, Analog Input):

Surge Protection/ Isolation	Secondary surge protection meets all AREMA recommendations for isolation and grounding. Primary surge protection is strongly recommended on all external interfaces (Note: Echelon LonTalk LAN Interface is <i>not</i> an external interface)
--------------------------------	---

1.6.12 Events/Alarms

A80273 (SEAR II):

Alarm Conditions	User definable via software
Memory Capacity	150,000 events/alarms standard and 350,000 with optional memory expansion

1.7 ORDERING INFORMATION

For SEAR II ordering information call Siemens Rail Automation Customer Service at 1-800-793-SAFE (1-800-793-7233).

1.8 TECHNICAL SUPPORT

For SEAR II Technical Support call Siemens Rail Automation Applications Engineering at 1-800-793-SAFE (1-800-793-7233).

SECTION II

INSTALLATION

2.0 INSTALLATION

The SEAR II can be installed at virtually any location provided the specification requirements as described in Section I are not exceeded.

2.1 PHYSICAL INSTALLATION

The physical installation of the SEAR II system involves mounting the units, making wiring connections, applying power and performing initial setup and checks before the system is put into final operation.

2.1.1 Mounting the Units

The SEAR II is designed for wall, shelf, or rack mounting (19-inch standard).

The Analog and Digital I/O Unit, A80258, is designed for wall, shelf or rack mounting (19-inch or 23-inch with extensions.)

The iLOD Unit, A80271 (intelligent Light-Out Detector) is designed for wall, shelf or rack mounting (via mounting plates.)

The Analog Unit, A80261, is designed for wall or shelf mounting, but by picking one of the configurations for the A80260 assembly, the A80261 unit can also be rack-mounted (19-inch or 23-inch rack).

The 53413 Mighty Modem unit, if required for the system, can be wall or shelf-mounted, and also rack-mounted (19-inch or 23-inch rack) by picking one of the configurations for the A80260 assembly.

2.1.2 Ventilation Requirements

The SEAR II, iLOD, Analog and Digital I/O Unit, Analog Unit and Mighty Modem do not require forced ventilation and are rated for a temperature range of -40°C to +71°C (-40°F to +160°F).

2.1.3 Surge Protection

The SEAR II, iLOD, Analog and Digital I/O Unit, Analog I/O Unit and Mighty Modem are each provided with internal secondary and tertiary surge protection circuits on all inputs, other than the Echelon Network and the serial ports (on the SEAR II). Siemens Rail Automation strongly recommends installing primary surge protection on external lines connecting to the event/recorder equipment. Refer to Section I, paragraph 1.5.11, *Reliability/Protection*, for specifications on surge protection.

2.1.4 Power Interface/Requirements

DC Power is supplied to each unit via a 4-pin connector accessible from the front panel. The power pins are labeled “B” and “N” to indicate polarity (B is positive, N is negative or return) and the connectors are keyed to ensure proper orientation. Refer to Section I, paragraph 1.5.1, *Power Requirements*, for specifications on power requirements. Refer to paragraph 2.1.11, *Connector Wiring Procedure*, for proper installation of wires in the power interface connectors.

Table 2-1 presents the pinout for the power and Echelon interface connector for the SEAR II, A80273, iLOD Unit, A80271, Analog and Digital Unit, A80258, and Analog Unit, A80261.

Table 2-1. Power & Echelon Interface Connector Pinouts

PIN NUMBER	LABEL	SIGNAL
1	ECH	Echelon B Wire
2	ECH	Echelon A Wire
3	N	Battery Return (negative)
4	B	Battery Voltage In (positive)

NOTE

NOTE

In order to reduce radiated electromagnetic interference from the SEAR II power cable, a clamp-on ferrite bead EMI filter must be installed on the cable before placing the unit in operation. Please refer to Appendix A in this manual for instructions on installing the EMI filters.

2.1.5 Echelon LAN Interface

The primary components of the SEAR II event recording system are nodes of an Echelon Local Area Network (LAN). Additional modules (such as the A80258 Analog and Digital I/O Unit or A80261 Analog Unit), or GCP/Motion Sensors may also be included in the system and communicate over the same LAN.

Nodes of the system do not need to be in close proximity to each other, provided all specification requirements for the LAN are met. Refer to Sec I paragraph 1.5.2.

When additional nodes on the LAN include one or more Grade Crossing Predictors (GCPs) or Motion Sensors (MS), each GCP/MS must have an optional LAN interface card installed (refer to Table 2-2 for interface options).

Table 2-2. GCP/MS LAN Interface Options

TYPE OF UNIT	PROCESSOR BOARD INSTALLED IN GCP/MS UNIT	ADDITIONAL BOARD REQUIRED FOR LAN INTERFACE	DESCRIPTION OF ADDITIONAL BOARD REQUIRED
GCP	A80014[1]	A80265[2]	The A80265 board contains the necessary components for communicating on the LAN and provides the interface [7] to the unit.
	A80044[3]		
	A80214[4]	A80255[5]	The A80255 board provides the required LAN interface [7] to the unit and provides an RJ-45 connector for a jumper connecting to the LAN circuitry that is contained on the Processor board.
MS	A80224[6]		

NOTES:

- [1] The A80014 (Processor Module, μ -GCP) does not contain LAN circuitry.
- [2] The A80265 (Retro External Data Recorder Interface) replaces the Recorder board when the SEAR II is used instead of the internal data recorder (and either the A80014 or A80044 Processor board is used in the unit). The A80265 is also compatible with the A80214 or A80224 Processor boards, however is not a preferred arrangement.
- [3] The A80044 (Processor Module, μ -GCP) does not contain LAN circuitry.
- [4] The A80214 (Processor Module, Micro GCP) contains the LAN circuitry on-board. This is the preferred GCP Processor board.
- [5] The A80255 (External Data Recorder Interface) replaces the Recorder board when the SEAR II is used instead of the internal data recorder (and either the A80214 or A80224 Processor board is used in the unit).
- [6] The A80224 (Processor Module, Motion Sensor) contains the LAN circuitry on-board.
- [7] For connection to a twisted pair LAN, an A80063 (GCP-To-Network Interface plug) must be connected to connector J1.

In addition to the optional interface card, a GCP-To-Network Interface plug (A80063) must be connected to the RECORDER (J1) port of each GCP/MS. These assemblies provide screw-down terminals for two sets of LAN twisted pair wires.

Each node on the LAN has an assigned node address and communicates with other nodes over a twisted pair cable. Data is transferred in messages containing the node addresses. The data transfer rate is 1.25Mbps.

The Echelon twisted pair interface shares the same connector with the DC input power for the unit (refer to Table 2-1). The total length of the network should not exceed 53 feet (16m). Refer to Section I, paragraph 1.6.2, *Echelon LonTalk Interface*, for the specifications for the interface.

NOTE

NOTE

The Echelon LAN must only be installed and utilized within the specifications in Section I, paragraph 1.6.2, Echelon LonTalk Interface.

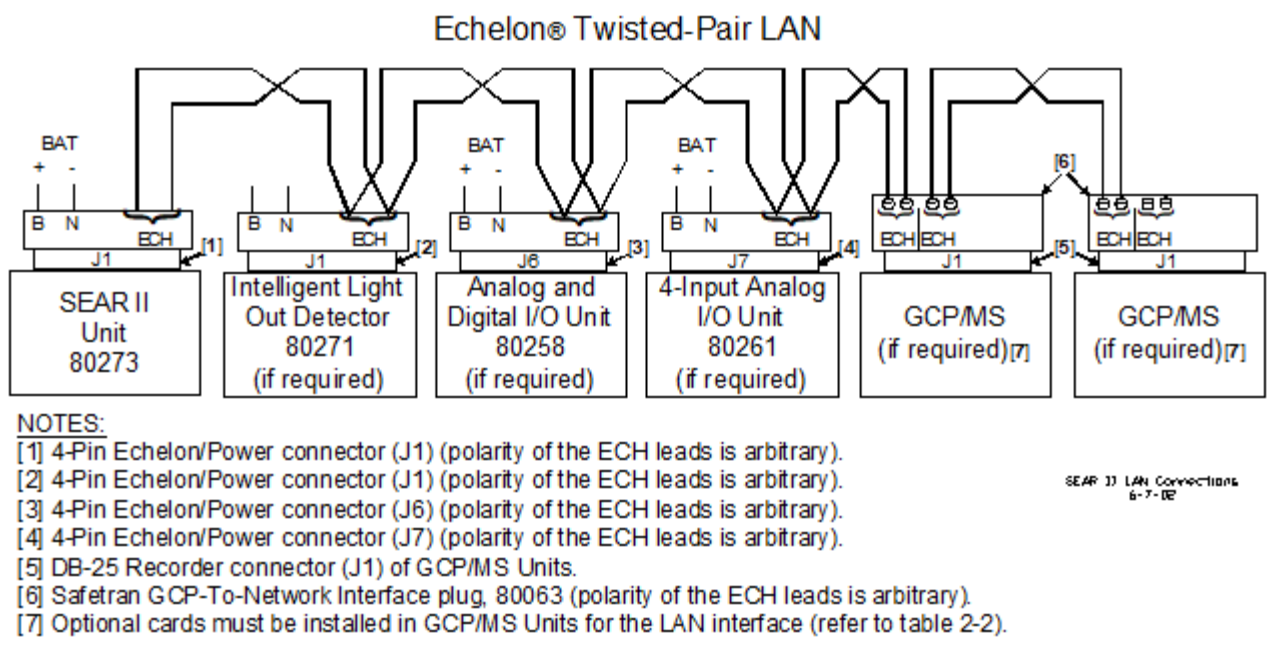

Figure 2-1. Typical SEAR II LAN Connections

CAUTION

CAUTION

DUE TO THE NATURE OF THE ECHELON LAN INTERFACE, THE SEAR II AND ALL DEVICES CONNECTED TO THE LAN SHOULD BE CONTAINED ENTIRELY WITHIN THE SAME SIGNAL CASE OR BUNGALOW.

CAUTION

CAUTION

DO NOT APPLY BATTERY VOLTAGE TO THE ECHELON CONNECTIONS AS THIS MAY DAMAGE THE INTERFACE TRANSCEIVERS.

NOTE**NOTE**

In order to reduce radiated electromagnetic interference from the SEAR II Echelon cable, a clamp-on ferrite bead EMI filter must be installed on the cable before placing the unit in operation. Please refer to Appendix A in this manual for instructions on installing the EMI filters.

2.1.6 Radio and Modem Interfaces

The A80273 SEAR II Unit front panel provides two RS232/RS422 interface connectors (J2-COM and J3-AUX) for serial communication with telephone dial-up modems, radios, or both radio and modem. These are DTE ports, which are keyed, 15-pin female (DB-15) and 25-pin female (DB-25) connectors labeled COMM and AUX respectively. When connecting to other DTE (typically computer) devices the cable should be a null-modem configuration, and when connecting to DCE (typically communications equipment) devices the cable should be straight through, contact-to-contact (not null-modem). Tables 2-3 and Table 2-4 present the pinouts for the COMM and AUX interface connectors.

Table 2-3. SEAR II A80273 COMM Interface Connector (J2) Pinouts

PIN NUMBER	SIGNAL [1]	INTERFACE STANDARD
4	Transmit Data-	RS232, RS422
2	Receive Data-	RS232, RS422
6	Request To Send Out-	RS232, RS422
8	Clear To Send In-	RS232, RS422
15	Signal Ground	RS232, RS422
9	Receive Clock+	RS422
11	Transmit Clock In+	RS422
7	Clear To Send In+	RS422
3	Transmit Data+	RS422
12	Transmit Clock In-	RS422
1	Receive Data+	RS422
10	Receive Clock-	RS422
13	Transmit Clock Out+	RS422
5	Request To Send Out+	RS422
14	Transmit Clock Out-	RS422

[1] For RS232 application, ignore signal polarity.

Table 2-4. SEAR II A80273 AUX Interface Connector (J3) Pinouts

PIN NUMBER [1]	SIGNAL [2]	INTERFACE STANDARD
2	Transmit Data-	RS232, RS422
3	Receive Data-	RS232, RS422
4	Request To Send Out-	RS232, RS422
5	Clear To Send In-	RS232, RS422
7	Signal Ground	RS232, RS422
9	Receive Clock+	RS422
12	Transmit Clock In+	RS422
13	Clear To Send In+	RS422
14	Transmit Data+	RS422
15	Transmit Clock In-	RS422
16	Receive Data+	RS422
17	Receive Clock-	RS422
18	Transmit Clock Out+	RS422
19	Request To Send Out+	RS422
24	Transmit Clock Out-	RS422

[1] Pins 1, 6, 8, 10, 11, 20 through 23, and 25 are unused.

[2] For RS232 application, ignore signal polarity.

2.1.7 Diagnostic Terminal and Printer Interfaces

The SEAR II Unit front panel provides an RS232 standard interface connector (J4) labeled USER, for communication with a diagnostic terminal (laptop PC) or a serial printer. This interface is a DCE port which uses a keyed, 9-pin female (DB-9) connector. The cable required to connect this interface is a standard RS232 (straight-through) cable terminated in a male 9-pin (DB-9) connector at the SEAR II end, and terminated in a connector at the diagnostic terminal (laptop PC) or printer end dependent upon the port that is used. For instance, the COM1 port requires a 9-pin (DB-9) or a 25-pin (DB-25) connector. Table 2-5 presents the pinouts for the USER interface connector.

Table 2-5. SEAR II A80273 USER Interface Connector (J4) Pinouts (RS232)

PIN NUMBER	SIGNAL
1	-
2	Transmit Data
3	Receive Data
4	-
5	Signal Ground
6	-
7	Clear To Send
8	Request To Send
9	-

2.1.8 Digital Input Interface

The SEAR II front panel provides three male 12-pin connectors (J5, J6 and J7) for connection to 18 digital input pairs to be monitored (six pairs each, positive & negative inputs). These inputs are to be wired to mating female 12-pin connectors supplied with the unit. Table 2-6 presents the digital input interface connector pin-outs.

Table 2-6. SEAR II Digital Input Interface Connector (J5, J6, J7) Pinouts

PIN NUMBER	SIGNAL
1	Digital Input Pair 1(J5), 7(J6), 13(J7) (positive)
2	Digital Input Pair 1(J5), 7(J6), 13(J7) (negative)
3	Digital Input Pair 2(J5), 8(J6), 14(J7) (positive)
4	Digital Input Pair 2(J5), 8(J6), 14(J7) (negative)
5	Digital Input Pair 3(J5), 9(J6), 15(J7) (positive)
6	Digital Input Pair 3(J5), 9(J6), 15(J7) (negative)
7	Digital Input Pair 4(J5), 10(J6), 16(J7) (positive)
8	Digital Input Pair 4(J5), 10(J6), 16(J7) (negative)
9	Digital Input Pair 5(J5), 11(J6), 17(J7) (positive)
10	Digital Input Pair 5(J5), 11(J6), 17(J7) (negative)
11	Digital Input Pair 6(J5), 12(J6), 18(J7) (positive)
12	Digital Input Pair 6(J5), 12(J6), 18(J7) (negative)

2.1.9 Analog Input and Relay Interface

The SEAR II front panel provides a male 10-pin connector (J8), of which six pins (1-6) are meant for connection to three batteries for monitoring (see Table 2-7 for pinouts). The other four pins on J8 (7-10) are connected to the contacts of two internal, non-vital output relays (see Table 2-7 for pinouts). The available contacts are Heel and Front (normally open.)

The three analog battery monitor inputs can sense (0 to 36 volts AC or DC). The isolated output relay contacts are capable of carrying 5 amps of current at 30VDC or 120VAC. These non-vital relays can be used to control outside lights, energize other external relays, etc.



CAUTION

THE INTERNAL RELAY CONTACTS ARE NON-VITAL AND THEREFORE SHOULD NOT DIRECTLY CONNECT TO OTHER VITAL CIRCUITS.

Table 2-7. SEAR II Analog Input/Relay Output Interface Connector (J8) Pinouts

PIN NUMBER	SIGNAL
1	Battery Monitor Input 1 (positive)
2	Battery Monitor Input 1 (negative)
3	Battery Monitor Input 2 (positive)
4	Battery Monitor Input 2 (negative)
5	Battery Monitor Input 3 (positive)
6	Battery Monitor Input 3 (negative)
7	Relay Output 1 (front)
8	Relay Output 1 (heel)
9	Relay Output 2 (front)
10	Relay Output 2 (heel)

2.1.10 Connector Wiring Procedure

The female connectors supplied with the SEAR II and expansion I/O modules will accept wire sizes in the range of #28 AWG to #14 AWG. The connectors contain spring-loaded cage-clamps for attachment of the wires. Each connector consists of a row of wire receptors and actuator spring holes to open and close the cage clamps (refer to Figure 2-2).

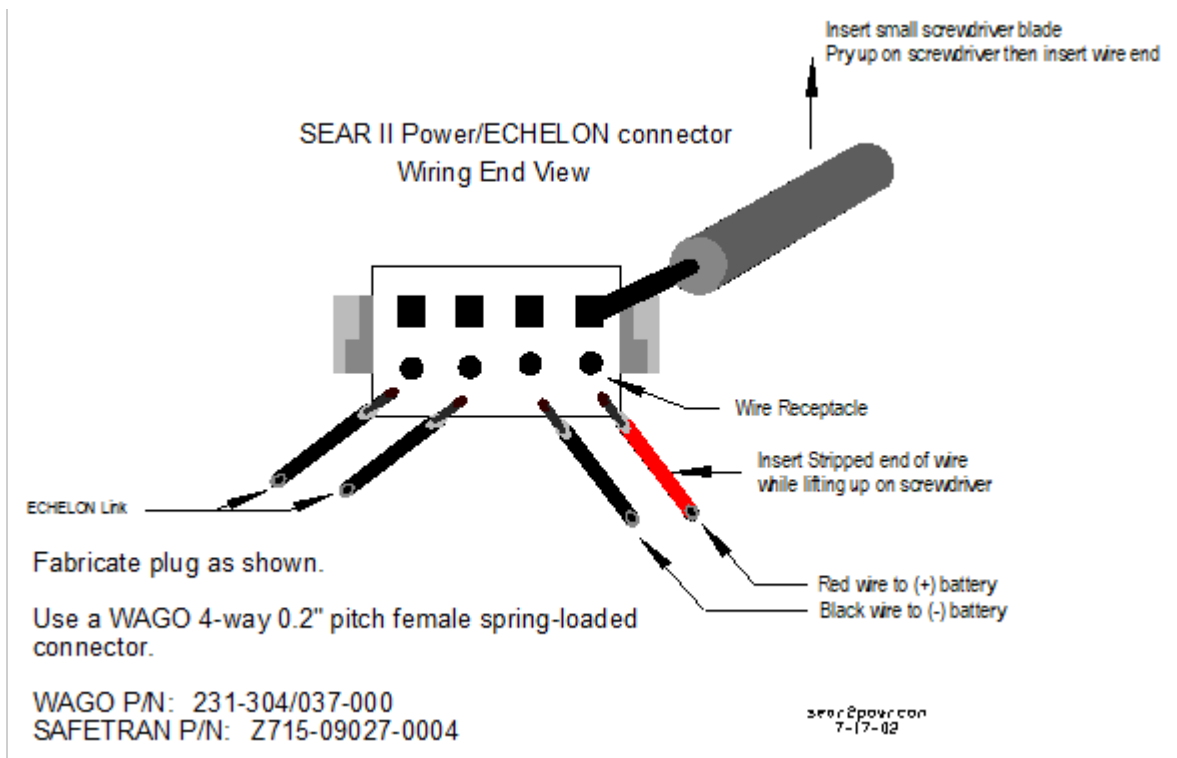

Figure 2-2. Typical DC Power/Echelon Connector Wire Insertion

Wire the connector as follows:

1. Remove the supplied connector from the mating receptacle on the front of the unit.
2. Select a proper gauge wire for the application (range is #28 to #14 AWG).
3. Strip approximately 1/4-inch (0.25 inch) of insulation from the end of the wire.
4. Insert Wago compression tool or small screwdriver into square holes at wiring end of the connector. Compress the wire receptacle contactor by squeezing the Wago tool toward body of connector or pry up on the small screwdriver. You will visually note that the contactor receptacle has opened up sufficiently to insert stripped wire. Fully insert wire into receptacle, taking care not to insert wire jacket insulation into metal contactors.
5. Remove Wago tool or screwdriver. Gently tug on wire just inserted to ensure the receptacle properly retains the installed wire.

NOTE

NOTE

To perform jumpering, twist the two wires together before inserting them into the wire receptor of the connector.

2.1.11 Wiring Applications

2.1.11.1 DC Power, Echelon, and Serial Interface Wiring

DC power input is generally wired from battery power (refer to Section I, paragraph 1.5.1 for power specifications). The LAN interface between units uses twisted pair bus (refer to Section I, paragraph 1.5.2 for LAN specifications). The serial interfaces use standard cables (refer to Section I, paragraph 1.5.7 for connector specifications).

Typical I/O wiring applications for the Echelon LAN and DC power are shown in Figure 2-1.

Typical I/O wiring applications for Serial Interface uses are shown in Figure 2-6.

2.1.11.2 Digital Input Wiring

Digital inputs are generally wired from spare relay contacts (+6 VDC to +36 VDC when energized).

When monitoring spare relay contacts, the digital inputs can be daisy-chained together, with the negative side of multiple inputs interconnected. When directly monitoring vital relay coils, digital inputs MUST NOT be daisy-chained. Both sides of each digital input must be wired directly to the vital relay terminals.

Typical digital input wiring applications are shown in following Figure 2-3.



WARNING

WARNING

THE SEAR II IS A NON-VITAL PRODUCT. CAUTION MUST BE TAKEN WHEN INTERFACING THE SEAR II TO ANY VITAL SIGNAL OR CROSSING EQUIPMENT AS THE SEAR II CAN NOT BE USED TO PERFORM, EITHER DIRECTLY OR INDIRECTLY, ANY VITAL FUNCTIONS. ENSURE THE SEAR II IS INSTALLED PER MANUFACTURER'S INSTRUCTIONS, AND/OR ALL EQUIPMENT INTERCONNECTIONS ARE IN COMPLIANCE WITH RAILROAD PROCEDURES AND SPECIFICATIONS.

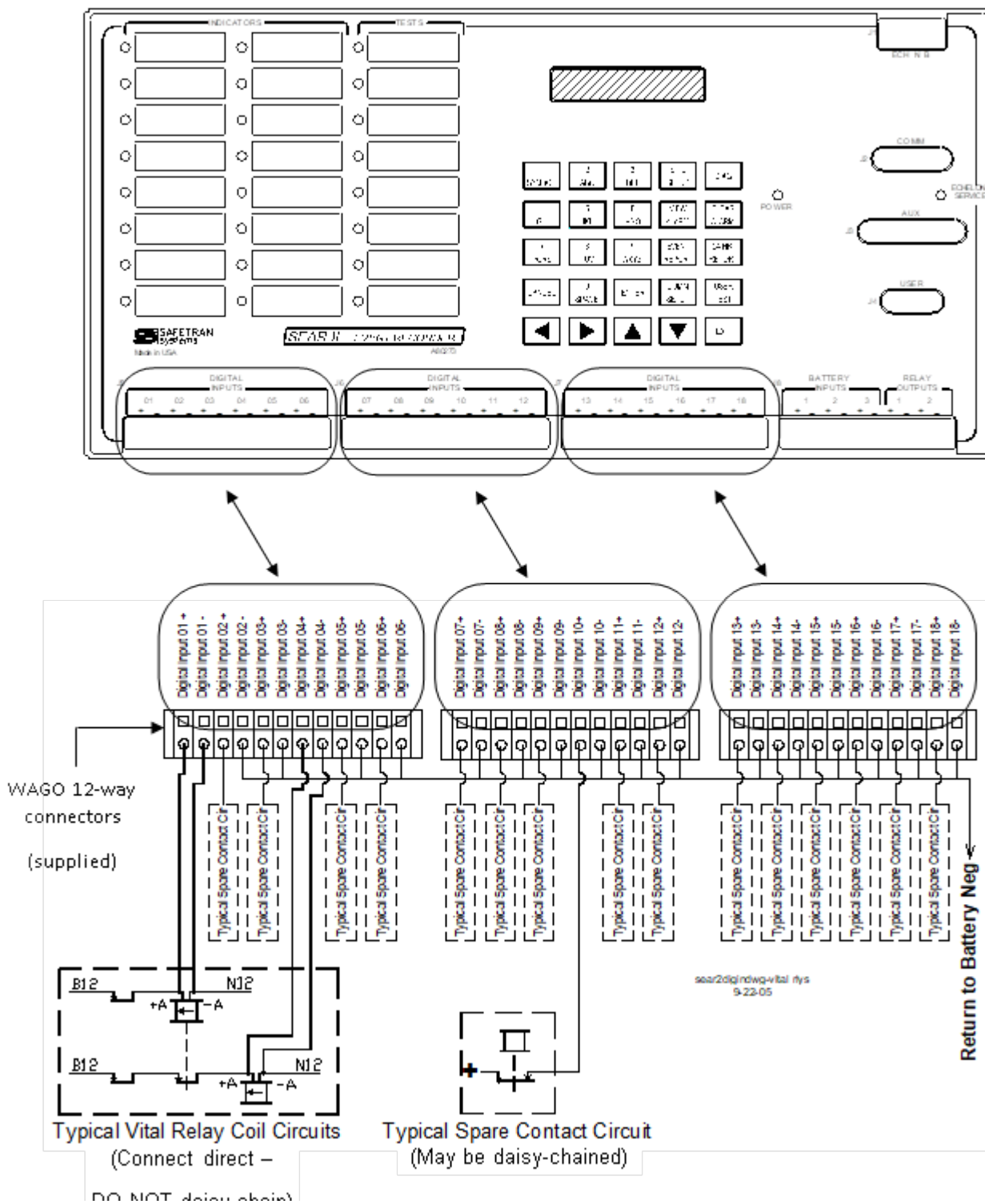

Figure 2-3. Typical Digital Input Wiring



WARNING

WHEN MONITORING VITAL RELAY COILS, BOTH SIDES OF EACH DIGITAL INPUT MUST BE WIRED DIRECTLY TO THE RELAY TERMINALS, AS SHOWN IN FIGURE 2-3.

2.1.11.3 Battery Monitoring Input Wiring

Battery Monitor inputs are generally wired to batteries and can read voltages in the range of 0-36 VDC.

Typical battery monitor input wiring applications are shown in Figure 2-4, below.

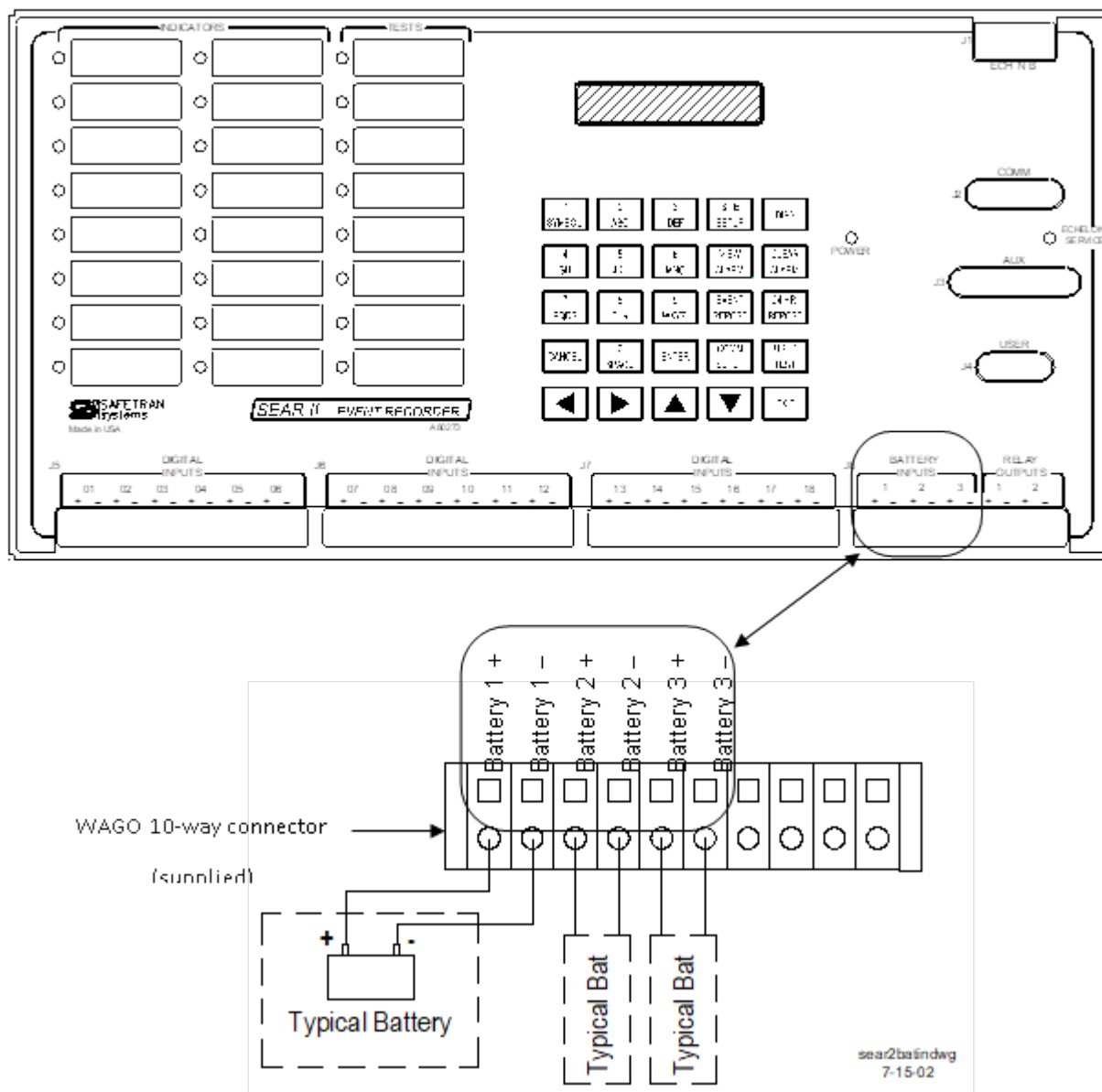

Figure 2-4. Battery Monitoring Input Wiring

2.1.11.5 Wiring for Serial Ports

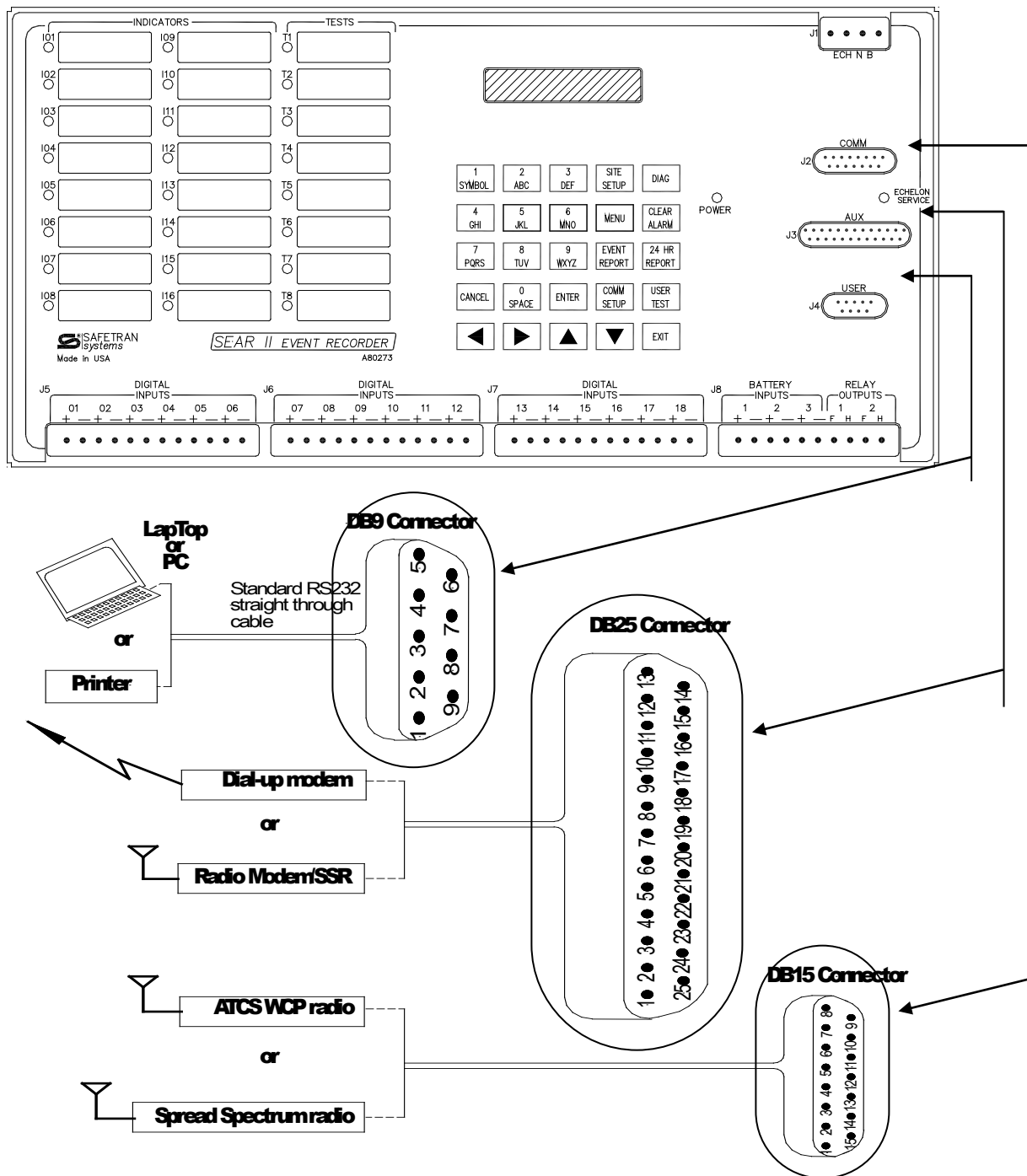

Figure 2-6. Serial Communications Wiring Arrangement

2.1.12 Initial Power-Up and Internal Battery Backup

SEAR II units are shipped from the factory with the internal lithium battery electronically disconnected from the circuit. The battery will be automatically connected when the unit is first powered up in the field. This feature is called “battery freshness seal” and is provided to maximize battery life.

Because of the battery freshness seal feature, the internal memory and the real-time clock will contain unknown data when the unit is powered up for the first time in the field. **Therefore, Time/Date adjustments should be performed immediately following the initial power-up sequence in the field.**

The internal lithium battery maintains power to the SRAMs and real-time clock when power to the unit is off. Under normal circumstances, the memory contents will be kept for a minimum of 3 years without power applied to the recorder. The SEAR II uses a 3.6 V AA-size lithium battery that is readily available at many retail outlets.

The SEAR II comes with two battery holders. Only one holder is loaded with a battery. Battery replacement can be performed with or without power applied to the SEAR II.



CAUTION

TO PREVENT LOSS OF POWER TO THE MEMORY AND REAL-TIME CLOCK DURING BATTERY REPLACEMENT WHERE THE UNIT IS NOT UNDER POWER, A NEW BATTERY SHOULD BE INSERTED INTO THE EMPTY HOLDER BEFORE REMOVING THE OLD BATTERY.

SECTION III

OPERATION

3.0 OPERATION

The SEAR II, part number A80273, provides 16 red LED indicators to enable a user to observe the status of system input/output. These LEDs can indicate status by being steady on, off, flashing slowly, or flashing fast. The SEAR II has eight multi-color LED indicators to enable a user to observe the status of user-defined tests or additional system input/output. These Test LEDs can indicate status through one of three colors (yellow, green, and red) and one of three flash rates (steady, slow flash, and fast flash).

The SEAR II has 18 digital inputs for monitoring DC or AC signals. There are also five analog inputs. Of these five analog inputs, three external inputs can be used to monitor batteries. The other two internal inputs measure internal temperature and the internal power supply.

The SEAR II has two non-vital relay outputs that can be used for any general purpose.

The local user interface of the SEAR II allows full access to system configuration settings, reports, and features. The Local User Interface (LUI) consists of a 2-line 20-character display and a 25-key keypad.

The SEAR II has three serial ports for communication with PC/laptop computers, modems, radios, and other external devices. If the inputs and outputs are not adequate for an application, the SEAR II can be extended using the Echelon LonTalk LAN. Additional input and output modules, as well as other Siemens Rail Automation equipment, can be connected directly to this network.

The two following fold-out illustrations present menu maps for the terminal and local user interfaces.

3.1 MENU MAPS

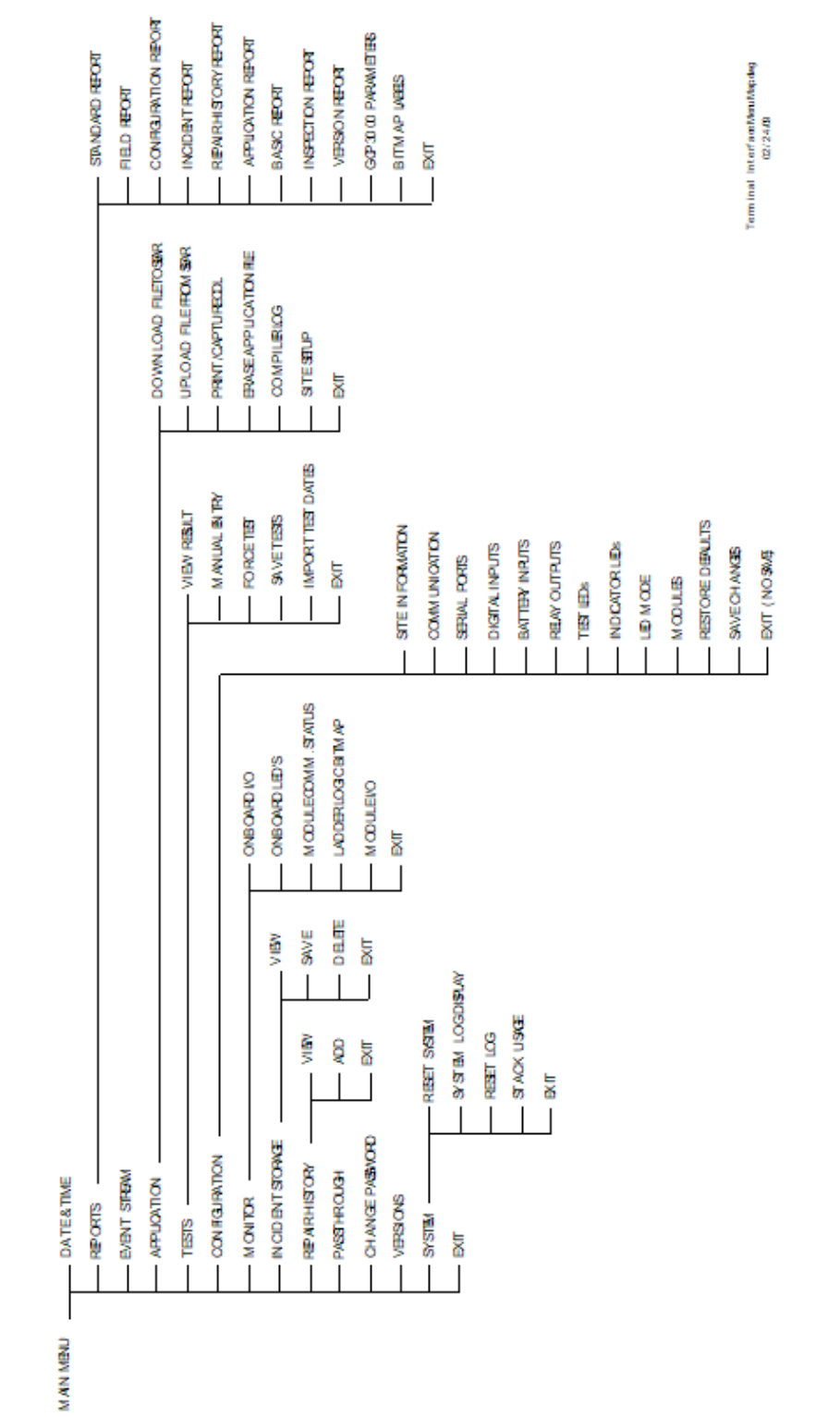
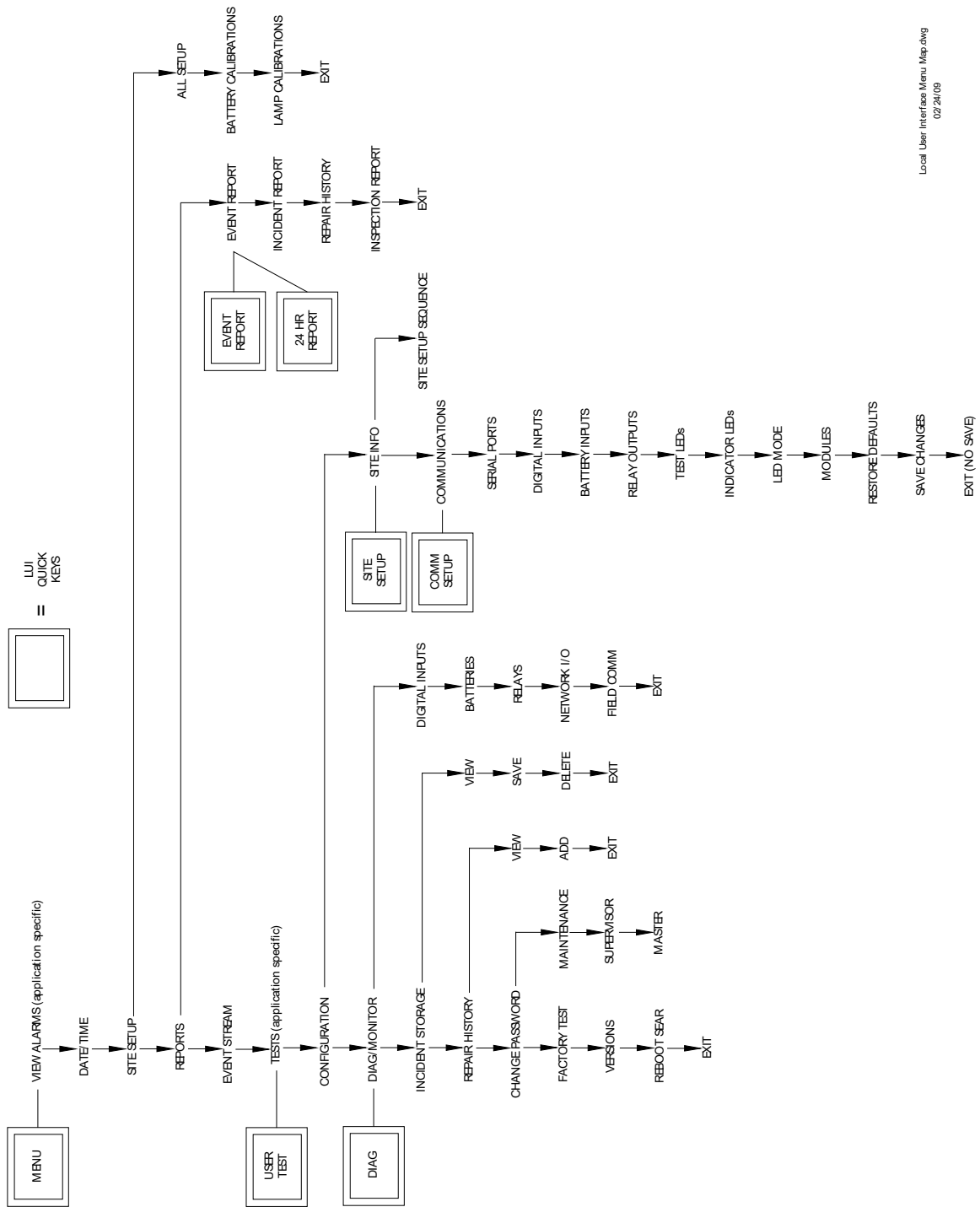

Figure 3-1 Terminal Interface Menu Map



Local User Interface Menu Map.dwg
02/24/09

Figure 3-2 Local User Interface (LUI) Menu Map

3.2 POWERING UP THE SYSTEM

3.2.1 The Terminal Boot Screen

When the system is first powered up, the SEAR II boot monitor runs. The boot monitor allows for upgrades of executive software in flash memory and performs some initial hardware testing. The following information is printed via the USER port of the SEAR II on a terminal emulator at 57600 baud, 8-N-1, if the loaded executive is valid.

```
SEAR II Booting...
Testing data bus...passed.
Testing address bus...passed.
Checking the executive CRC...valid

Boot Options (Valid Executive)
1. Download Executive
2. Run Debugger
3. Run Executive
Choice > _
```

Figure 3-3. SEAR II Terminal Emulation Boot Screen.

The boot monitor performs two basic hardware tests at startup verifying the system's data bus and address bus are operating correctly. If a failure occurs, a message is printed on the USER port and the LUI display shows specific information about the failure. The system then resets. If boot failure messages repeat, replace the SEAR II unit.

The boot monitor checks the integrity of the executive by performing a 32-bit CRC calculation. If the executive is not valid, the boot monitor will not run it and the program will wait 5 seconds for the download of a new executive. If no download begins, the unit will reset and the process repeats until an executive is loaded. See paragraph 3.1.3 for instructions on downloading.

If the executive CRC check passes, the boot monitor will begin executing the executive in five seconds, if a new executive download is not started. After successful execution of the executive the following line will be displayed on the terminal screen.

```
Boot Monitor complete. Running SEAR II Executive.
```

3.2.2 The LUI Boot Display

In addition to the terminal emulation screen, you can monitor the SEAR II power-up process on the display of the LUI (Local User Interface). Following is the normal boot sequence as shown on the LUI display.

```
CHECK EXEC CRC
EXEC CRC VALID
SEAR II BOOTING
BOOT COMPLETE
```

Following a successful boot-up and execution of the executive, the LUI display will automatically default to the LUI top level as shown below. See paragraph 3.3.1 - *LUI Top Level* for details.

```
12:44 6-27-2002
Site: Siemens Rail Aut
```

3.2.3 Upgrading the Executive Software

Upgrading the Executive can only be performed from the Terminal Emulator screen. Downloading a new Executive must be started within 5 seconds after the “Choice” prompt is displayed near the end of the SEAR II boot monitor screen.

```
Boot Options (Valid Executive)
1. Download Executive
2. Run Debugger
3. Run Executive
Choice > _
```

Figure 3-4. The Boot Monitor Choice Prompt.

To download new Executive software, do the following:

1. Know beforehand the location of the new Executive file as you will only have one minute to locate and select it. The Executive file can be downloaded from any device. i.e., hard drive, floppy disk, CD or network/Internet.
2. Ensure the terminal emulator is running with an active connection to the SEAR II.
3. Restart/power up the SEAR II.
4. At the Boot Options “Choice” prompt, press **1** within five seconds. Terminal screen displays:

```
Waiting for executive download...
```

5. Using the terminal emulator `Transfer` command, you now have 60 seconds to locate and begin `SENDING` the new Executive binary file using the Zmodem protocol. (Depending on the terminal emulation software you are using, this process may be slightly different). After the Executive is downloaded it will be burned into the SEAR II FLASH memory.
6. When the Boot Monitor resumes, press **3** at the Boot Options “Choice” prompt (or wait 5 seconds) and the new Executive will automatically begin to execute.

Following is a typical screen display sequence if the upgrade is successful:

```
Choice > 1
Waiting for executive download... done.
Checking the executive CRC...valid (37E56D71)
Erasing existing executive...done.
Programming new executive...done.
Checking the executive CRC...valid (37E56D71)

Boot Options (Valid Executive)
1. Download Executive
2. Run Debugger
3. Run Executive
Choice > 3
Boot Monitor complete. Running SEAR II Executive.
```

3.3 USING THE TERMINAL INTERFACE

To view the Terminal Interface, connect a standard serial cable (DB9 male to DB9 female) between the SEAR II USER serial port and the serial comm port of a PC/laptop computer. The SEAR II USER serial port and PC/laptop comm port settings must match (baud rate, data bits, stop bits, etc.) in order to communicate. (Refer to Table 3-13 for USER serial port default settings).

You can run HyperTerminal or any other available terminal emulation software on the computer. HyperTerminal is included with the standard Windows® 9x/NT/2000/XP installation. The SEAR II uses ANSI terminal emulation.

With the computer connected to the SEAR II and the terminal emulation software running, press **CTRL+L** to start the terminal interface session. The following screen is displayed.

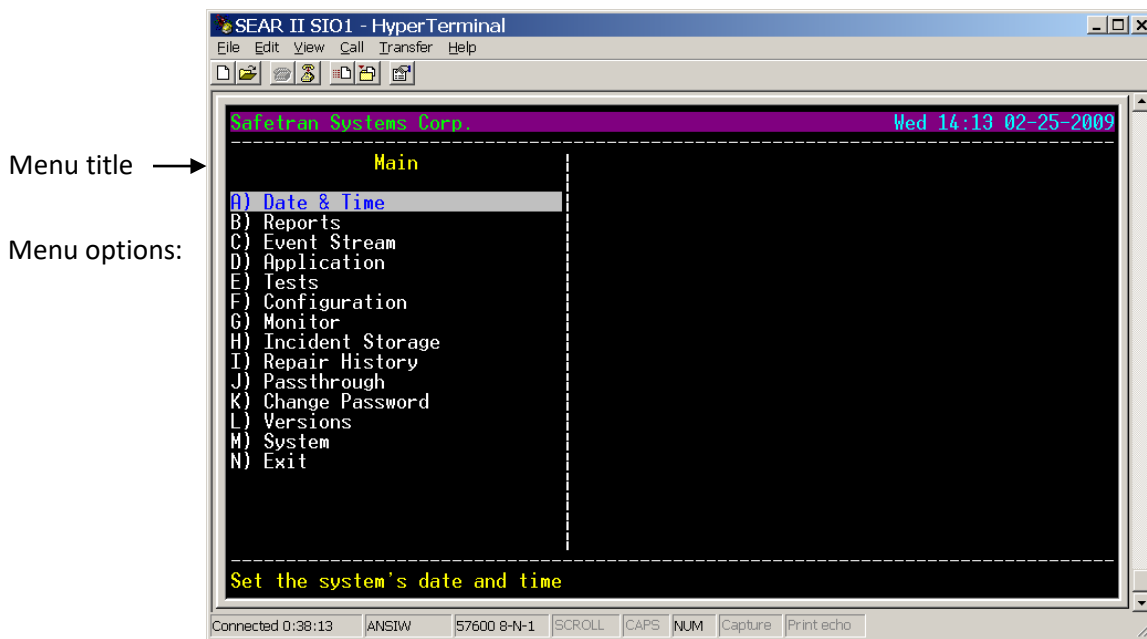

Figure 3-5. SEAR II Terminal Interface Main Menu

3.3.1 Terminal Interface Main Menu Options

Date & Time	Change the system's real-time clock to a date/time
Reports	View a report (event, configuration, incident, etc.)
Event Stream	View events as they occur
Application	Download/Upload Application File, View Compiler Log
Tests	View/Run Tests
Configuration	Modify/label system configuration settings
Monitor	View/change system I/O status
Incident Storage	View/save/delete incident reports
Repair History	View/add repair history entries
Passthrough	Enable Passthrough mode for COMM or AUX ports
Change Password	Change user passwords
Versions	Show current Executive and Application versions
System	Reset system /system log display/reset log/stack usage
Exit	Exit the terminal session

3.3.2 Navigating Terminal Screen Menus

The menus can be navigated using the keyboard up and down arrows or the letter key displayed next to the menu item. To select the highlighted item, press the keyboard ENTER key. (May be labeled ↵).

When there are right and left arrows next to the menu title, pressing the keyboard right and left arrow keys will provide additional navigation. For example:

```
<- Serial Ports ->
```

Pressing the ESC key on the keyboard automatically exits the displayed menu and reverts back to the previous menu.

Pressing CTRL+X keys exits the terminal session.

To refresh the screen, press CTRL+R keys.

The following summarizes the menu control actions.

↑	Highlight previous menu option
↓	Highlight next menu option
←	Depends on context, usually go back a channel
→	Depends on context, usually go forward a channel
ESC	Go up (back) one menu level
ENTER	Execute the highlighted menu option

CTRL+L Start/Restart terminal interface session

CTRL+X Logout of the terminal session

CTRL+R Refresh the terminal screen

NOTE

If no action is performed on the terminal interface for more than 10 minutes, the session will automatically be terminated and the user will be logged out of the current session.

If data is changed and no further action is performed, after 10 minutes you will be prompted to save the changes. If you do not respond within another 10 minutes, the changes will be discarded and the prior configuration will remain in effect.

NOTE

3.3.3 Terminal Data Entry

Data may be entered through a **data entry field** or a **list field**. For data entry fields, the default data displayed may be accepted by pressing ENTER. If you wish to change the data, you can start typing and the default data will be overwritten. Pressing ENTER temporarily saves it until prompted to permanently save changes. Pressing ESC cancels the operation. You may also press CTRL+X and logout of the terminal interface. If no entry is made for 10 minutes, the terminal interface session automatically ends. Following is an example of a **data entry field**.

```
Site name: [Siemens Rail Automation Corp.____ ]
```

List fields are indicated by the “^v” symbols after the brackets around the field. The arrow keys (←, →, ↑, and ↓) are used to make selections. The up and down arrow keys move through the list 1 item at a time. The right and left arrow keys move through the list 15 items at a time. Pressing ENTER chooses the selection, and pressing ESC cancels the operation. You may also press CTRL+X and logout of the terminal interface. If no selection is made for 10 minutes, the terminal interface session is automatically ended. The following is an example of a **list field**.

```
Auto DST adjust: [ Yes ]^v
```

3.4 USING THE LOCAL USER INTERFACE (LUI)

The LUI consists of a 2-line 20-character vacuum florescent display, a 25-key keypad, and a beeper. Menus are navigated with the ARROW keys, the ENTER key, and the CANCEL key. Text and numbers can easily be entered using the cell phone style number/letter keys. There are also special function keys for quick access to SEAR II settings and information. See Figure 3-6.

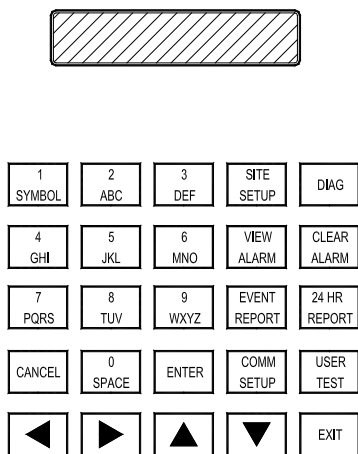

Figure 3-6. LUI Keypad and Display

3.4.1 LUI Top Level

The top level of the LUI is the initial/default display mode of the SEAR II. The LUI top level shows the time and date on the first line of the display, and scrolling system information on the second line. Important messages may be displayed here such as a low internal battery warning. To return to the top level of the LUI from any other level, press the **CANCEL** key and confirm the action at the prompt.

NOTE

NOTE

```
12:44  6-27-2002
SITE:  Siemens Rail Aut
```

If there is no activity on a LUI sub-level for five minutes, it will automatically return to the top level.

3.4.2 Navigating LUI Menus

When the SEAR II is at the LUI top level, the local display shows the system date/time on the first line, and site information scrolling on the second line. Pressing the **ENTER** key or the **MENU** key at this point brings up the LUI main menu.

The first line of the main menu display shows the menu title. The last character of the first line is a down arrow symbol, indicating this is a menu with additional menu options. The second line of the display shows the current menu option.

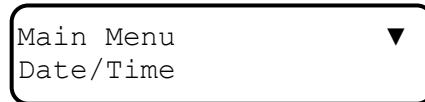

The **DOWN ARROW** key is used to scroll through the various menu options which display on the second line. The **UP ARROW** key moves through the menu options in the opposite direction.

Pressing the **ENTER** key will execute the currently displayed menu option.

To return to the top level of the LUI from any other level, simply press **CANCEL** and respond YES when prompted.

Pressing **CANCEL** will prompt, "CANCEL? YES or NO." Answering YES will return you to the LUI Top Level. Answering NO will negate the action.

Pressing the **EXIT** exits the current menu and returns to the previous level. This action is the same as pressing the DOWN ARROW key until EXIT is displayed, and then pressing ENTER.

3.4.3 LUI Main Menu Options

Pressing the **ENTER** key from the top level enters the main menu. Following is a description of the LUI main menu options.

View Alarms	View active alarms
Date/Time	Change the system's real-time clock to a date/time
Site Setup	Run site setup
Reports	View a report (event, configuration, incident, etc.)
Event Stream	View events as they occur
Tests	View/Run tests
Configuration	Modify/label system configuration settings
Diag/Monitor	Monitor and control system I/O status
Incident Storage	View/save/delete incident reports
Repair History	View/add repair history entries

Continued next page

Change Password	Change user passwords
Factory Test	Enter factory test mode
Versions	View current Executive and Application versions
Reboot SEAR	Force SEAR II to reboot
Exit	Go back to the top level

3.4.4 LUI Data Entry

- **Basic Operation** - When entering text strings or numbers on the LUI, the number/letter keys are used. The keys are used like cell phone keys. The keys will behave differently depending on the type of field being edited. The LEFT ARROW and RIGHT ARROW keys are used to navigate back and forth on the edited string. The UP and DOWN arrow keys will modify the character above the cursor. Pressing the ENTER key after entering text will temporarily store the changed data in memory until you are prompted to permanently save changes. Pressing the CANCEL key while entering text will prompt you to cancel the operation and return to the top level. Pressing the EXIT key skips the current entry or returns you to the previous level.
- **Changing Default Line Data** – If you wish to modify a default string or number, you simply start entering the string and the default string will automatically be erased.
- **Entering Keypad Numbers and Letters** - When entering data in an *Alphanumeric* field, each consecutive press of a numbered key will produce the characters printed on the key. For example, pressing the #2 key repeatedly produces: **2, A, B, C, a, b, c**, then the sequence is repeated. After entering a character the cursor will move to the next character position approximately one second later, if the character is not changed.

If the data field is *numeric* only, each press of a numbered key will only produce the specific number, as shown on the key.

If the data field is *Alpha* only, no numbers will be allowed.

- **Option Lists** - Some fields may only allow you to pick from a list of options. These fields are indicated by a block cursor over the first character of the listed item. To scroll through the list of options, press the DOWN or UP ARROW keys to navigate the list. The RIGHT and LEFT arrow keys will move through the list 16 items at a time (For example, when you select `Main Menu>Diag/Monitor/Digital Inputs/Single Input`). Press the ENTER key to select the displayed option.
- **Saving Data** – The configuration of the SEAR II remains unchanged until the “SAVE CHANGES” option on the configuration menu is selected. This option maybe several levels above the submenu item undergoing an edit. You will always be prompted to save changes when leaving the configuration menu.

NOTE**NOTE**

Any time data is changed, the program will not return to the normal LUI top level until the user answers the prompt to save the changes, regardless of which method is used.

3.4.5 LUI Quick Keys

LUI “quick keys” are shortcut keys which, when pressed, take the user directly to a specific menu. Following are descriptions of the LUI quick keys.

- **SITE SETUP** – The SITE SETUP key is a shortcut to Main Menu > Site Setup
- **DIAG** - Pressing the DIAG key from the top level is a shortcut to the Diag/Monitor Menu.
- **MENU** – Opens main menu options screen.
- **CLEAR ALARM** - The operation of this key is application program dependent.
- **EVENT REPORT** - The EVENT REPORT quick key is a shortcut to Main Menu > Reports > Event Report (provides option for Standard or Basic report format).
- **24 HR REPORT** - The 24 HR REPORT quick key is the same as the EVENT REPORT quick key, except the date/time range of the report is automatically set to the last 24 hours. No date/time must be entered.
- **COMM SETUP** - Press the COMM SETUP key from the top level menus to go straight to the options detailed in subsection 3.6.2, “Communication Ports.”
- **USER TEST** – View or run tests. These are application program dependent.

3.5 SETTING THE DATE & TIME

Terminal screen:

```
Main Menu > Date & Time
```

LUI display:

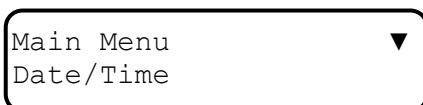

```
Main Menu
Date/Time
```

Enter date and time directly. They will format exactly as entered. Use the 24-hour format when entering the hour.

The date and time are entered on one line for both the LUI and the terminal screen. On the LUI you will also be prompted for the automatic daylight saving adjustment setting and the timezone of the unit. The new settings can be saved or discarded at the prompt.

After the time has been entered, the system time and real-time clock will be updated. There will also be two events logged in the event buffer – one event with the old time as a time stamp, and one event with the new time as the time stamp. An event report will show entries similar to the following lines.

```
Mon 4-29-2002 9:30:17.5 Time modified
Mon 4-29-2002 9:41:00.5 New system time
```

3.6 VIEWING REPORTS

Terminal screen:

```
Main Menu > Reports
```

Using the **terminal screen** menus the following reports can be accessed:

```
Standard Report
Field Report
Configuration Report
Incident Report
Repair History Report
Application Report
Basic Report
Inspection Report
Version Report
GCP3000 Parameters
Bitmap Labels
```

Note that the Basic Report is a replica of the Standard Report, except that the following events are omitted: MTSS gate up; MTSS gate tip; MTSS bell power; MTSS bell audio; and all iLOD events. Both the Standard and Basic Report information can be captured to flash memory as an Incident Report which includes tamper protection.

The `Standard`, `Field`, `Application` and `Basic` reports prompt to enter the start date/time, and the end date/time. The parameter defaults are set to view the previous 24 hours. By entering all zeros the entire Event buffer can be accessed. See following subsection on Event Storage for details.

When accessing the `Configuration Report`, the entire SEAR II configuration is displayed.

Accessing the `Incident Report` will display any saved incidents. See *Incident Storage* for details.

Selecting the `Repair History` report will allow you to display ALL entries at once, or you may select from the option list and view a subset of entries.

In addition to viewing the report on screen, some reports can be captured and printed as a text file. This option requires the user to enable text capturing on the terminal emulator. Depending on the terminal emulation software you use, you can capture text and save it to a disk file, or send it directly to a printer. For details, refer to you application's user manual or help file.

The `Application Report` shows the alarms and events logged by the application program.

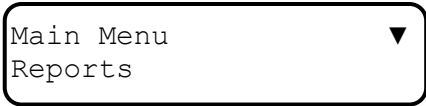
LUI display:

Main Menu
Reports

Using the **LUI display screens** the following reports can be accessed:

EVENT REPORT (will query for Standard or Basic format)
INCIDENT REPORT
REPAIR HISTORY
INSPECTION REPORT

When viewing reports on the LUI, you must use the **ARROW** and **ENTER** keys to access the various sub-menus. The LUI does not have the capability to send reports to a file/printer.

3.6.1 Event Storage

Terminal screen:

Reports > Standard Report

LUI display:

Report Menu
Event report

The SEAR II maintains an internal event buffer where all system events are stored. The event buffer is circular (newest event replaces oldest) and stored in internal battery-backed RAM. The unit can store up to 150,000 events and 350,000 events with the optional memory expansion.

**CAUTION****CAUTION**

IF THE BACKUP BATTERY IS BAD AND POWER IS LOST TO THE UNIT, THE ENTIRE EVENT MEMORY WILL BE ERASED.

To better utilize memory resources, events are stored in a compressed format. When event reports are viewed, the compressed events are extracted to a readable date/time with the channel tag and state names printed. If state names or channel tags are changed, all old events are displayed with the new tags and state names.

Along with the events stored in the event buffer there is an event database where the present state of every I/O channel is kept. The application logic and the diag/monitor screens use it to show the present status of system I/O. There is also an event database where the state of I/O just before the first event in memory is kept. With that information, the state of any I/O channel can be determined at any point in time from the first event in the event buffer to the last.

3.7 CONFIGURATION DATA

Configuration data can be viewed or modified using the terminal interface or LUI. If you modify any configuration data and press ESC or CANCEL to return to the previous menu(s) (rather than exiting a menu), you will eventually be prompted to save your changes.

Terminal screen:

```
Main Menu > Configuration
```

LUI display:

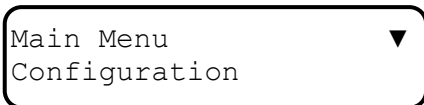

Using the terminal menu screens or the LUI display, the following options can be accessed:

Terminal Screen option menus

- Site Information
- Communication
- Serial Ports
- Digital Inputs
- Battery Inputs
- Relay Outputs
- Test LED's
- Indicator LED's
- LED Mode
- Modules
- Restore Defaults
- Save Changes
- Exit (no save)

LUI Display option sequence

- Site info
- Communications
- Serial ports
- Digital inputs
- Battery inputs
- Relay outputs
- Test LED's
- Indicator LED's
- LED Mode
- Modules
- Restore defaults
- Save changes
- Exit (no save)

Accessing the Site Information option allows the user to modify the site name, milepost & DOT number.

3.7.1 Site Information

Terminal screen:

Configuration > Site Information

LUI display:

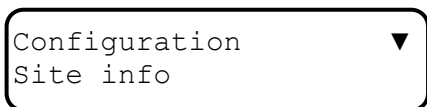

Accessing the `Site Information` option allows the user to modify the site name, milepost, DOT number, auto DST (Daylight Savings Time) adjustment, and current time zone.

3.7.2 Communication Settings

Terminal screen:

Configuration > Communication

LUI display:

Press the “Comm Setup” quick key.

Keep in mind that when configuring communications, if the user picks an Echelon device such as the VHF communicator for the communications medium, that doesn't add the device into a module slot in the configuration. Either the application program must do it or the user will still have to perform the ADD MODULE procedure (see 3.6.10.1 on page 3-31).

The Sear II may be configured to operate with external communication devices. The user defined settings for each device are described in Table 3-1. The following subsections, 3.6.2.6 and 3.6.2.7 provide background information on ATCS networking.

Table 3-1. Communications Settings

SITE TYPE	SETTINGS
No Communication	N/A
Bullhorn/MODBUS	POLL ID
NODE	Site address, office address, office site, backup site 1, backup site 2, field device
Collector	Site address, office address, poll ID, office device, office port, field device
CDS-902X (Cellular Modem)	Port

NOTE: User will be prompted to save when settings are changed.

3.7.2.1 No Communication

A SEAR II unit with the site type set to No Communication has no link to an office system and no alarms or messages are handled by the unit.

3.7.2.2 Collector (master)

A SEAR II unit with the site type set to Collector is the master unit in the ATCS enhanced routing protocol that has a direct link to the office system. SEAR II units configured as Nodes report their alarms and status to this site. The unit then forwards the messages to the office system. A Collector site has the following settings.

Table 3-2. Collector Settings

SETTING	DESCRIPTION
Site Address	ATCS address of this site. The address is a type 7 field address with the following format: 7.RRR.LLL.GGG.SS.DD.
Office Address	ATCS address of the Wayside Alarm Management System software. The address is a type 2 office address with the following format: 2.RRR.NN.DDDD.
Poll ID	The Genisys protocol poll ID of this site.
Office Device	The device used to communicate with the office. This setting can be any of the following: Spread Spectrum Radio (RS232) MCM (RS232) Spread Spectrum Radio (Echelon) MCM (Echelon) Dial Modem (RS232)
Office Port	If the selected office device is RS232, the serial port the device is connected to must be specified (COMM or AUX). Echelon devices do not require an Office Port setting.
Phone Number	If the selected office device is Dial Modem (RS232), the phone number for the office system must be specified.
Init String	If the selected office device is Dial Modem (RS232), an initialization string for the modem may be specified. NOTE: Auto answer for the modem must be disabled. The SEAR II handles phone answering.
Field Device	The device used to communicate with Node SEAR II sites in the network. This setting can be any of the following: VHF Communicator (Echelon) Spread Spectrum Radio (RS232) Spread Spectrum Radio (Echelon) VHF Radio (RS232) None
Field Port	If the selected field device is RS232, the serial port the device is connected to must be specified (COMM or AUX). Echelon devices do not require a Field Port setting.

3.7.2.3 Node (slave)

A SEAR II unit with the site type set to Node is a slave unit in the ATCS enhanced routing protocol used to “hop” alarms to a Collector. Messages may hop from one Node to the next until they reach a collector where they will be forwarded to the office system. A Node has the following settings.

Table 3-3. Node Settings

SETTING	DESCRIPTION
Site Address	ATCS address of this site. The address is a type 7 field address with the following format: 7.RRR.LLL.GGG.SS.DD.
Office Address	ATCS address of the Wayside Alarm Management System software. The address is a type 2 office address with the following format: 2.RRR.NN.DDDD.
Office Site	ATCS address of the primary site to send message bound for the office system. This site may be the Collector or another Node that is closer to the Collector. The address is a type 7 field address with the following format: 7.RRR.LLL.GGG.SS.DD.
Backup Site 1	ATCS address of the first site to route messages through if communication is lost with the Office Site. The address is a type 7 field address with the following format: 7.RRR.LLL.GGG.SS.DD.
Backup Site 2	ATCS address of the second site to route message through if communication is lost with both the Office Site and Backup Site 1. The address is a type 7 field address with the following format: 7.RRR.LLL.GGG.SS.DD.
Field Device	The device used to communicate with other SEAR II sites in the network. This setting can be any of the following: VHF Communicator (Echelon) Spread Spectrum Radio (RS232) Spread Spectrum Radio (Echelon) VHF Radio (RS232) None
Field Port	If the selected field device is RS232, the serial port the device is connected to must be specified (COMM or AUX). Echelon devices do not require a Field Port setting.

3.7.2.4 CDS-902X

A SEAR II unit configured with a site type of CDS-902X sends alarm messages to the office system using the Dataremote CDS-902X cellular modem. The messages are sent to the office using the Short Message Service (SMS) or the phone system. A CDS-902X site has the following settings.

Table 3-4. CDS-902x Settings

SETTING	DESCRIPTION
CDS-902X Port	The serial port the cellular modem is connected to (COMM or AUX)

3.7.2.5 Bullhorn/Modbus

A SEAR II unit configured with a site type of Bullhorn/Modbus communicates with the office using a Bullhorn cellular unit and the Modbus protocol. A Bullhorn/Modbus site has the following settings.

Table 3-5. Bullhorn/Modbus Settings

SETTING	DESCRIPTION
Poll ID	Modbus protocol poll identifier.

3.7.2.6 SEAR II Networks

SEAR II devices can be deployed as single standalone units or as multiple units operating in a master-slave configuration.

Standalone units communicate with the Wayside Alarm Management System via WCC networks and Direct Lines. These devices are assigned unique ATCS addresses, can process requests and generate replies and alarms using ATCS messages.

Multiple units can be arranged in a master-slave configuration, with the Collector (master) providing the communications link to the Wayside Alarm Management System via WCC networks or Direct Lines. Each device must be assigned a unique ATCS address, can process requests and generate replies and alarms using ATCS messages. These messages are routed by the collector unit to the node (slave) units and back using the enhanced routing protocol.

Each device, in both arrangements, sends an unsolicited heart-beat message at regular time intervals and always upon boot-up. This message is used by the collector for identifying all nodes, by the WCC network for learning routing paths, and by the Wayside Alarm Management System for tracking each device’s health and configuration status. The interval of the heart-beat message is configurable in the Wayside Alarm Management System. The settings default to the following:

- Collector with direct/dial line 2:00 AM every day
- Collector with WCC network Every 30 minutes
- Node Every 12 hours

3.7.2.7 SEAR II ATCS Enhanced Routing Protocol

The Enhanced routing aspect of the protocol allows a device to send messages to non-reachable nodes by routing messages through nodes within the range of the communications device. Each node, upon receiving an incoming packet must break open the internal ATCS header of the packet to determine its final destination. Then the packet is routed through the assigned node in this node's routing table in order to reach its destination.

Each node keeps an internal routing table, updated with the LAST Sender address forwarding an Originator's packet. Since packets can be routed through various Senders, it is important for each node to keep the LAST Sender of a packet as the 'access node' assigned to the Originator.

Each node has a 'Primary' node that is used to forward data to the office system and 2 alternate addresses to use if the Primary does not function correctly.

The figure below shows a master-slave layout. Each slave is shown with the configured primary and alternate routes.

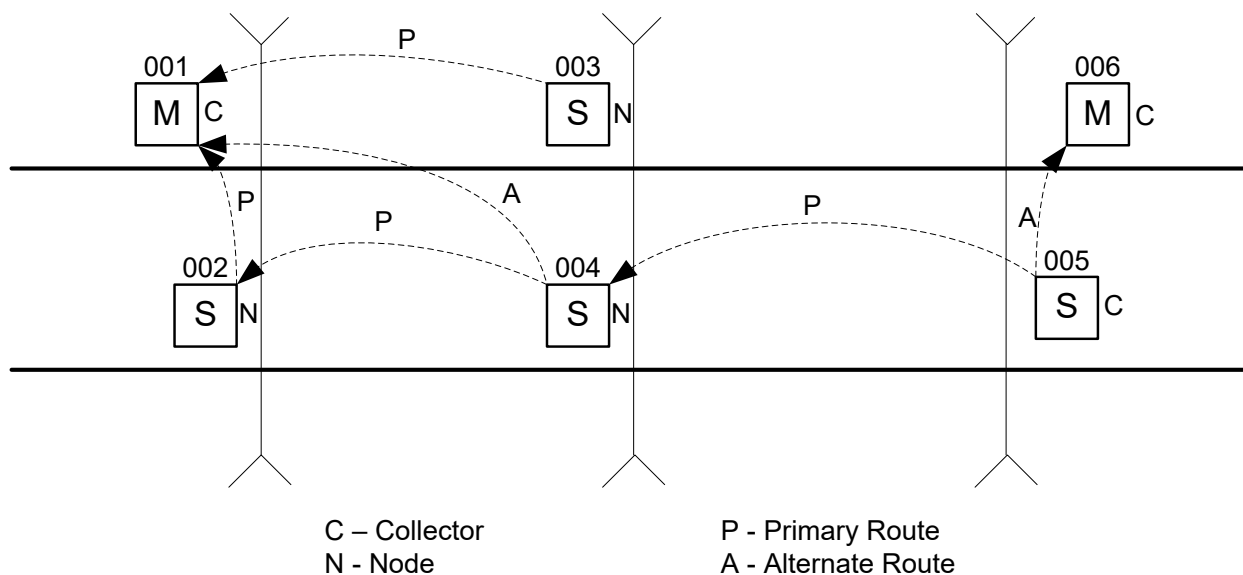

Figure 3-7. Collector-Node SEAR-II Field Layout

There are two basic message types to be transmitted over the network. An alarm type and a regular type. Alarms have higher priorities than regular messages. Any incoming alarm packet received by a node are placed in the top of its outbound queue, ahead of all other non-alarm packets. New alarms do not preempt existing alarm packets.

A SEAR II node will retry its primary address (office site address) five times. The timeout between tries depends on the group number of the unit’s ATCS address and can range from 5 seconds to 20 seconds. Once all 5 tries have failed, the unit will continue to try the primary address (office site address) 5 more times with a timeout that ranges from 5 to 60 minutes depending on the group number of the unit’s ATCS address. After all 5 tries have failed, the unit then tries the 1st backup address 5 times with a 5 to 60 minute timeout. Then the 2nd backup address. If the second backup fails, the unit continues to try the primary address once every five or six hours until messages are successfully transmitted and communication is restored to normal.

3.7.3 Serial Ports

Terminal screen:

```
Configuration > Serial Ports
```

LUI display:



The SEAR II has three onboard serial ports. The USER port is RS-232 while the COMM and AUX ports are RS-232/RS-422. The COMM port is designed for connection to an external radio. The USER port is dedicated for the terminal interface. The AUX port can be used for other external equipment such as a modem.

The settings for each serial port are described in 3-2.

Table 3-6. Serial Port Settings

SETTING	DESCRIPTION
Baud	Bits per second,
Data bits	Number of bits for the data portion of a character frame (8 or 7).
Parity	Specifies if a parity bit should be present in character frames and if it should be even or odd. Can be set to none, even, or odd.
Stop bits	Number of bits to signal the end of character frames (1 or 2),
Flow control	Specifies if flow control should be used (none or hardware),

3.7.4 Digital Inputs

Terminal screen:

Configuration > Digital Inputs

LUI display:

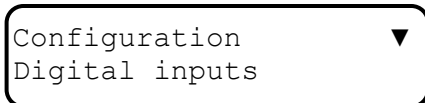

Digital inputs are monitored approximately every 10 milliseconds. A digital input can be in one of three states: OFF, ON, or TOGGING. An input is in the 'off' state if the voltage on the input has been less than 1.0 VDC (or AC peak) for the user defined OFF de-bounce period. An input is in the 'on' state if the voltage on the input has been above 6.0 VDC (or AC peak) for the user defined ON de-bounce period. The input is declared 'toggling' if it changes state 4 or more times within the user defined toggle period.

The settings for each digital input are described in Table 3-7.

Table 3-7. Digital Input Settings

SETTING	DESCRIPTION
Algorithm	Choose from TSS (Trackside Sensor), GFT (Ground Fault Tester), or Discrete (Default Setting).
Discrete Algorithm Input Settings	
Name	Up to 20 characters in length and used to describe the input but not shown in the event reports
Tag	Up to 10 characters in length and used to identify the digital input in event reports and on local menus
State names: OFF, ON, TOGGLE	Up to 12 characters in length for each state name, and displayed in event reports and local menus.
On de-bounce	Number of milliseconds an input must be energized before it is declared ON.
Off de-bounce	Number of milliseconds an input must be de-energized before it is declared OFF.
Toggle period	Number of milliseconds within an input changing state 4 or more times is declared TOGGING.
TSS Algorithm Input Settings	
Name	Up to 20 characters in length and used to describe the input but not shown in the event reports
Tag	Up to 10 characters in length and used to identify the digital input in event reports and on local menus
Gate Tip and Bell Sensor Inputs	These signal types are listed on the terminal display, but the polarity assignments are fixed so they are user un-modifiable.
GFT Algorithm Input Settings	
Name	Name of the GFT unit. Up to 20 characters in length and used to describe the input but not shown in the event reports
Tag	Tag of the GFT unit. Up to 10 characters in length and used to identify the input in event reports and on local menus
Battery 1 Name	Up to 20 characters in length and used to describe the battery connected to input 1 of the ground fault tester.
Battery 1 Tag	Up to 10 characters in length and used to identify the battery connected to input of the ground fault tester in event reports and on
Battery 2 Name	Up to 20 characters in length and used to describe the battery connected to input 2 of the ground fault tester.
Battery 2 Tag	Up to 10 characters in length and used to identify the battery connected to input 2 of the ground fault tester in event reports and

3.7.5 Battery Inputs

Terminal screen:

```
Configuration > Battery Inputs
```

LUI display:

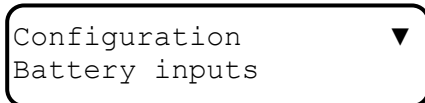

Battery monitoring inputs can be used to monitor the voltage on standard 12 VDC and 24 VDC batteries. They may also be used to monitor any DC voltage from 0 VDC to 36 VDC. There are five battery monitor channels but only three are externally accessible. One internal channel is dedicated to monitoring the system's internal temperature and the other internal channel is dedicated to monitoring the system's internal power supply.

The settings for each battery input are described in Table 3-8.

Table 3-8. Battery Input Settings

SETTING	DESCRIPTION
Name	Up to 20 characters long and used to describe the input but not used in event reports.
Tag	Up to 10 characters long and used to identify the input in event reports and local menus.
Sample Period	Number of milliseconds between processing of the input. Events for the input can be logged on this interval only. Internally, the SEAR II samples the inputs every 10 milliseconds regardless of this setting.
Resolution	Specifies the change in volts (or degrees Fahrenheit) required before an event will be logged into the SEAR II event buffer.
Samples to Average	Specifies the number of consecutive 10 millisecond samples to average together to determine the voltage present on the input. This value can be set to no averaging, 2 samples, 4 samples, 8 samples, 16 samples, or 32 samples.

Note that the SEAR II samples the input every 10 milliseconds, regardless of the 'Sample Period' setting. The 'Sample Period' setting determines how often the SEAR II will average the samples to determine if an event is logged. The number of 10 millisecond samples that are averaged is determined by the 'Samples to Average' setting. If this calculated average results in a quantity that differs by more than the amount defined in 'Resolution' from the previously logged value, then a new event is logged.

For example, the battery inputs can be configured:

Resolution = 0.5 V
Sample Period = 100 ms
Samples to Average = 32 samples

In this case, every 100 milliseconds the SEAR II averages the last 32 samples of 10 milliseconds each (a period of 320 millisecond) and compares it to the last logged value of battery voltage on the input. If the new average value is different by 0.5 V or more from the last logged value, an event is logged. If the input's voltage changes rapidly, an event could be logged every 100 milliseconds.

3.7.6 Relay Outputs

Terminal screen:

Configuration > Relay Outputs

LUI display:

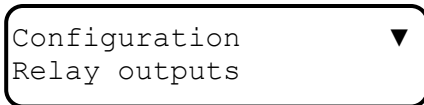

Relay outputs can be controlled to the OFF state, ON state, TOGGLING state, or PULSED state. In the OFF state, the relay contacts are open. In the ON state the relay contacts are closed. In the TOGGLING state, the relay contact is opening and closing at the user specified duty cycle and period. In the PULSED state the relay changes from its current state to the opposite state for the user specified pulse duration.

The settings for each relay output are described in Table 3-9.

Table 3-9. Relay Output Settings

SETTING	DESCRIPTION
Name	Up to 20 characters long and used to describe the relay but not used in event reports
Tag	Up to 10 characters long and used to identify the relay in event reports and local menus
State names	Up to 12 characters in length and displayed in event reports and local menus
ON pulse time	Specifies the duration of an ON pulse in seconds
OFF pulse time	Specifies the duration of an OFF pulse in seconds
Toggle period	Specifies the time between cycles of toggling the relay output from off to on, and back to off in seconds
Duty cycle	Specifies the percentage of time the relay is in the ON state when toggling

3.7.7 Test LEDs

Terminal screen:

```
Configuration > Test LED's
```

LUI display:



The eight test LEDs can be used to show the state of any channel of system I/O or the status of any application program operation. The test LEDs can be off, red, green, yellow, red flashing slow, green flashing slow, yellow flashing slow, red flashing fast, green flashing fast, or yellow flashing fast. The LEDs are primarily used to indicate the status of user tests performed by the application program.

The function of the Test LEDs is completely dependent on the application program. But when there is no application program loaded, the 16 indicator LEDs track the state of the digital inputs 1 to 16, and the first two test LEDs track the state of digital inputs 17 and 18. Test LEDs T3 through T8 are unused.

The settings for each test LED are described in Table 3-10.

Table 3-10. Test LED Settings

SETTING	DESCRIPTION
Name	Up to 20 characters long and used to describe the relay but not used in event reports
Tag	Up to 10 characters long and used to identify the relay in event reports and local menus
State names (OFF, RED, GREEN, YELLOW, RED FLASH SLOW, GREEN FLASH SLOW, YELLOW FLASH SLOW, RED FLASH FAST, GREEN FLASH FAST, YELLOW FLASH FAST)	Up to 12 characters in length and displayed in event reports and local menus

3.7.8 Indicator LEDs

Terminal screen:

```
Configuration > Indicator LED's
```

LUI display:

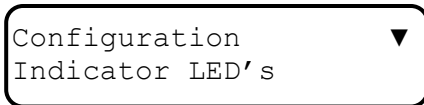

The 16 indicator LEDs can be used to show the state of any channel of system I/O or the status of any application program operation. The indicator LEDs can be off, on, flashing slow, or flashing fast.

The function of the Indicator LEDs is completely dependent on the application program. But when there is no application program loaded, the 16 indicator LEDs track the state of the digital inputs 1 to 16, and the first two test LEDs track the state of digital inputs 17 and 18

The settings for each indicator LED are described in Table 3-11.

Table 3-11. Indicator LED Settings

SETTING	DESCRIPTION
Name	Up to 20 characters long and used to describe the LED but not used in event reports
Tag	Up to 10 characters long and used to identify the LED in event reports and local menus
State names (OFF, ON, FLASHING SLOW, FLASHING FAST)	Up to 12 characters in length and displayed in event reports and local menus

3.7.9 LED Mode

Terminal screen:

```
Configuration > LED MODE
```

LUI display:

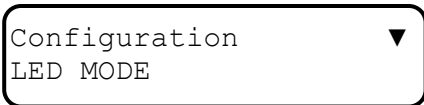

The LED MODE allows the user to select the function of the LED indicators and test LEDs. The options for LED MODE are DIGITAL TRACK and APP CONTROL. Digital Track uses LED indicators 1-16 and test LEDs 1-2 to show the state of the digital inputs 1-18.

If a digital input is on, its corresponding LED will be on and vice versa. A toggling digital input will be displayed as a fast flash on the LED display. APP CONTROL mode gives the application program control of the LEDs. In APP CONTROL, the state of the LEDs can be changed from the LED monitor screen.

3.7.10 Expansion Modules

Terminal screen:

```
Configuration > Modules
```

LUI display:

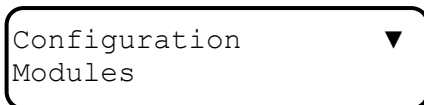

If additional I/O is required for the application, the system can be expanded through the Echelon LonTalk LAN. Many types of modules may be networked with the SEAR II including the A80258 Analog and Digital I/O Unit, the SDIM, and the Intelligent Light Out Detector (iLOD).

Each module can be named. The modules' I/O can also have user defined names, tags, and states. The Neuron ID and software version of each module are tracked in the system's Repair History and the latest ID and version are stored and displayed in the module's configuration.

The settings for each module are described in Table 3-12.

Table 3-12. Module Settings

SETTING	DESCRIPTION
Name	Up to 20 characters long and used to describe the module. The name is also used in event reports and local menus.
Type	Set to one of the supported module types

Selecting the Modules option on the Configuration Menu will cause the following options to display. These are described in the following subsections.

Terminal Screen option menus

```
Add Module
Change Module
Replace Module
Remove Module
Identify Module
Exit
```

LUI Display option sequence

```
Add Module
Change Module
Replace Module
Remove Module
Identify Module
Factory Cal iLOD
Exit
```

3.7.10.1 Add Module

To add a networked module, it must first be wired into the Echelon network and powered on.

Select the type of the module you wish to install from the displayed list field "Module Type," then press ENTER. You will then be prompted to name the module, do so, and press ENTER. If you wish to edit the module settings, choose YES at the next prompt, EDIT SETTINGS. If NO, you will be asked to press the service button. The module is now installed.

3.7.10.2 Change Module

Change module allows the user to edit the settings of a particular module. You will select which module to change and then be prompted for the module name. After this, the user will automatically be directed to the Edit Settings screen for that particular module.

3.7.10.3 Replace Module

Replace module is used to swap out an existing module with another. You will be asked, MODULE TO REPLACE and then be asked to press the service button. The old module must be removed and the new module must be wired in it's place before performing this operation.

3.7.10.4 Remove Module

This function is used to remove a module. The user will be asked which module to remove and then prompted, ARE YOU SURE ? (YES/NO).

3.7.10.5 Identify Module

The identify module feature will identify a module when the user presses the Echelon service button.

3.7.10.6 Factory CAL iLOD

This item is used by Siemens Rail Automation personnel only.

3.7.11 Restoring Default Configuration Settings

Terminal screen:

```
Configuration > Restore Defaults
```

LUI display:

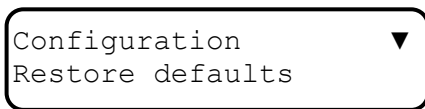

It is possible to restore the system's configuration settings back to the factory defaults if deemed necessary. Restoring factory defaults is not recommended, since all existing configuration settings will be overwritten and lost. The operation may be performed from the terminal interface or the LUI. You will be prompted to verify that you want to reset all configuration settings. Select YES and press ENTER to restore the factory defaults.

This restore default function configures the unit with the values in Table 3-13 regardless of applications. The one exception is that if you are logged into the terminal user interface through one of the serial ports, the restore default value functions will not change the serial settings for that port.

Note that by default, there are no Echelon modules interfaced to the SEAR II.

Table 3-13 over the next several pages shows the factory default settings for the SEAR II configuration.

Table 3-13. Default Configuration Settings

FACTORY DEFAULT SETTINGS		
SITE INFORMATION		
PARAMETER	DEFAULT DATA	
Site Name	Siemens Rail Automation Corp.	
Milepost	1234.56	
DOT Number	123456a	
Auto DST Adjust	Yes	
Time Zone	Eastern	
GMT Offset	-05:00	
COMMUNICATION PORTS		
CONNECTOR	PARAMETER	DEFAULT DATA
COMM (J2)	Baud	9600
	Data bits	8
	Parity	none
	Stop bits	1
	Flow control	none
	Connected device	none
AUX (J3)	Baud	9600
	Data bits	8
	Parity	none
	Stop bits	1
	Flow control	none
	Connected device	none
USER (J4)	Baud	9600
	Data bits	8
	Parity	none
	Stop bits	1
	Flow control	none
	Connected device	none

Table 3-13 Default Configuration Settings – continued

DIGITAL INPUTS		
CHANNEL #/CONNECTOR	PARAMETER	DEFAULT DATA
DIGITAL INPUT Channel 01 (J5)	Name	Digital Input 1
	Tag	DI01
	OFF name	Off
	ON name	On
	TOGGLE name	Toggling
	On de-bounce	100
	Off de-bounce	100
	Toggle period	1000
DIGITAL INPUT Channel 02 (J5)	Name	Digital Input 2
	Tag	DI02
	OFF name	Off
	ON name	On
	TOGGLE name	Toggling
	On de-bounce	100
	Off de-bounce	100
	Toggle period	1000
↓ (Channel 03-17)	↓ (Channel 03-17)	↓ (Channel 03-17)
DIGITAL INPUT Channel 18 (J7)	Name	Digital Input 18
	Tag	DI18
	OFF name	Off
	ON name	On
	TOGGLE name	Toggling
	On de-bounce	100
	Off de-bounce	100
	Toggle period	1000

Table 3-13 Default Configuration Settings – continued

BATTERY MONITOR INPUTS		
CHANNEL #/CONNECTOR	PARAMETER	DEFAULT DATA
BATTERY INPUT Channel 1 (J8)	Name	Battery Monitor 1
	Tag	BM1
	Sample Period	100
	Resolution	0.5
	Samples to Average	32
BATTERY INPUT Channel 2 (J8)	Name	Battery Monitor 2
	Tag	BM2
	Sample Period	100
	Resolution	0.5
	Samples to Average	32
BATTERY INPUT Channel 3 (J8)	Name	Battery Monitor 3
	Tag	BM3
	Sample Period	100
	Resolution	0.5
	Samples to Average	32
Internal Temperature Channel	Name	Temperature
	Tag	Int. Temp
	Sample Period	100
	Resolution	5
	Samples to Average	32
Internal Vcc Channel	Name	Vcc
	Tag	Vcc
	Sample Period	100
	Resolution	0.2
	Samples to Average	32

Table 3-13 Default Configuration Settings – continued

RELAY OUTPUTS		
CHANNEL #/CONNECTOR	PARAMETER	DEFAULT DATA
RELAY OUTPUT Channel 1 (J8)	Name	Relay Output 1
	Tag	RLY1
	OFF name	Open
	ON name	Closed
	TOGGLE name	Toggling
	PULSE name	Pulse
	On pulse time	1
	OFF pulse time	1
	Toggle Period	1
	Duty Cycle	50
RELAY OUTPUT Channel 2 (J8)	Name	Relay Output 2
	Tag	RLY2
	OFF name	Open
	ON name	Closed
	TOGGLE name	Toggling
	PULSE name	Pulse
	On pulse time	1
	OFF pulse time	1
	Toggle Period	1
	Duty Cycle	50

Table 3-13 Default Configuration Settings – continued

INDICATOR LEDS		
LED	PARAMETER	DEFAULT DATA
INDICATOR LED 01	Name	LED 01
	Tag	I01
	OFF name	Off
	ON name	On
	Flash Slow Name	Flash slow
	Flash Fast Name	Flash fast
INDICATOR LED 02	Name	LED 02
	Tag	I02
	OFF name	Off
	ON name	On
	Flash Slow Name	Flash slow
	Flash Fast Name	Flash fast
↓ (LED 03-15)	↓ (LED 03-15)	↓ (LED 03-15)
INDICATOR LED 16	Name	LED 16
	Tag	I16
	OFF name	Off
	ON name	On
	Flash Slow Name	Flash slow
	Flash Fast Name	Flash fast

Table 3-13 Default Configuration Settings – continued

TEST LEDS		
LED	PARAMETER	DEFAULT DATA
TEST LED 1	Name	Test LED 1
	Tag	T1
	OFF name	Off
	Red name	Red
	Green name	Green
	Yellow name	Yellow
	Red flash slow name	Red slow
	Green flash slow name	Grn slow
	Yellow flash slow name	Ylw slow
	Red flash fast name	Red fast
	Green flash fast name	Grn fast
	Yellow flash fast name	Ylw fast
TEST LED 2	Name	Test LED 2
	Tag	T2
	OFF name	Off
	Red name	Red
	Green name	Green
	Yellow name	Yellow
	Red flash slow name	Red slow
	Green flash slow name	Grn slow
	Yellow flash slow name	Ylw slow
	Red flash fast name	Red fast
	Green flash fast name	Grn fast
	Yellow flash fast name	Ylw fast
↓ (LED 3-7)	↓ (LED 3-7)	↓ (LED 3-7)

Table 3-13 Default Configuration Settings – continued

LED	PARAMETER	DEFAULT DATA
TEST LED 8	Name	Test LED 8
	Tag	T8
	OFF name	Off
	Red name	Red
	Green name	Green
	Yellow name	Yellow
	Red flash slow name	Red slow
	Green flash slow name	Grn slow
	Yellow flash slow name	Ylw slow
	Red flash fast name	Red fast
	Green flash fast name	Grn fast
	Yellow flash fast name	Ylw fast
PASSWORDS		
PASSWORD MODE	DEFAULT DATA	
Maintenance	sscmaint	
Supervisor	sscsuper	
Siemens Rail Automation Personnel	ssc	

3.8 MONITORING SYSTEM I/O

Terminal screen:

Main Menu > Monitor

LUI display:

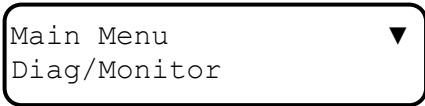

Main Menu
Diag/Monitor ▼

Monitoring system I/O on the LUI is slightly different from monitoring system I/O on the terminal interface. Both methods are explained below.

3.8.1 Monitoring Onboard I/O on the Terminal

Monitor Menu > Onboard I/O

Selecting the **Onboard I/O** screen menu option allows you to monitor the status of all Digital Inputs (DI01-DI18) as well as each Battery Input (BM1-BM3) and the internal temperature and Vcc voltage. Additionally, the two Relay Outputs (RLY1 and RLY2) can be manually controlled and set to OFF, ON, PULSE, or TOGGLE.

The Onboard I/O screen displays each Input/Output by its “Wire Tag” and “State” name, as defined in the Configuration Menu for Digital Inputs, Battery Inputs and Relay Outputs.

The following commands can be entered to change the state of a Relay Output:

Fx = OFF **Ox** = ON **Px** = PULSE **Tx** = TOGGLE

Where **x** = 1 or 2 (RLY1 or RLY2)

Examples:

To set RLY1 ON, enter: **O1** (letter-O 1)

To set RLY2 to TOGGLE, enter: **T2**

Only the Relay Outputs can be changed from this screen.

3.8.2 Monitoring Onboard LEDs on the Terminal

Monitor Menu > Onboard LED's

Selecting the **Onboard LEDs** screen menu option allows you to monitor the status of all Indicator LEDs (I01-I16) and Test LEDs (T1-T8), as well as test the functionality of each LED.

The following commands can be entered to change the state of an **Indicator LED**: Some applications support the LED test functionality described below.

Where **xx** = 01 – 16

Ixx0 = OFF (letter-I **xx** zero)

Ixx1 = ON (letter-I **xx** one)

IxxF = FLASH FAST

IxxS = FLASH SLOW

Examples:

To set Indicator LED #2 ON, enter: **I021** (letter-I 02 one)

To set Indicator LED #13 to FLASH FAST, enter: **I13F** (letter-I 13 F)

The following commands can be entered to change the state of a **Test LED**:

Where **x** = 1 – 8

Tx0 = OFF (letter-T **x** zero)

TxR = RED ON

TxY = YELLOW ON

TxG = GREEN ON

TxFR = RED FLASH FAST

TxSR = RED FLASH SLOW

TxFY = YELLOW FLASH FAST

TxSY = YELLOW FLASH SLOW

TxFG = GREEN FLASH FAST

TxSG = GREEN FLASH SLOW

Examples:

To set Test LED #3 to GREEN ON, enter: **T3G**

To set Test LED #6 to RED FLASH FAST, enter: **T6FR**

To set Test LED #7 to YELLOW FLASH SLOW, enter: **T7SY** (letter-Y)

3.8.3 Monitoring Digital Inputs on the LUI

Using the LUI you can monitor the state of every channel of system I/O.

LUI display:

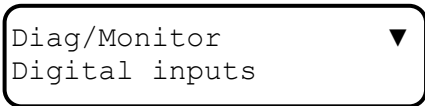

There are two ways to view the status of the onboard digital inputs, you can view them all at once in an abbreviated form, or you can view one at a time with the channel name and state names used. You are prompted for the view mode when selecting the menu option.

In the **“All inputs”** view mode, all 18 onboard digital inputs are shown on the second line of the display in groups of six. The top line of the display scrolls the legend for the input states. An OFF input is shown as a ‘0’, an ON input is shown as a ‘1’, a TOGGLING input is shown as a ‘T’, and a TSS/GFT input is shown as an X. Following is an example of the “All inputs” view.

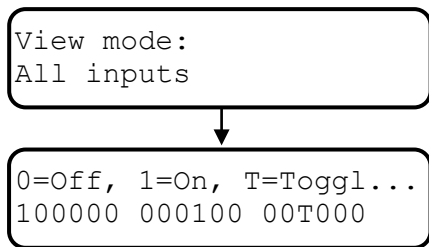

In the **“Single input”** view mode, you are prompted for the input to view. The digital inputs are listed by their wire tags. After selecting the desired input, the top line of the display scrolls the wire tag and the name for the input. The second line of the display shows the state of the input by its state name. For example, an input with a name of “Crossing Relay”, a wire tag of “XR”, and an ON name of “UP” would look the following way on the display.

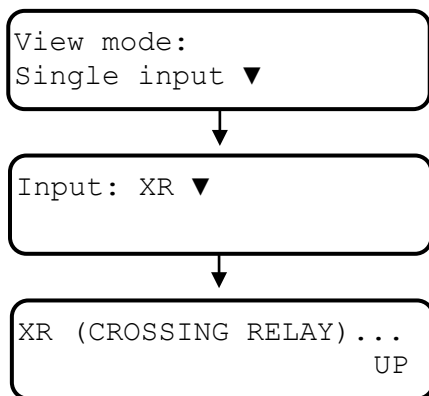

3.8.4 Monitoring Battery Inputs on the LUI

Using the LUI you can monitor the state of all three battery Inputs.

LUI display:

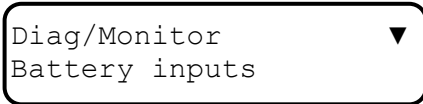

After selecting “Battery inputs” from the Diag/Monitor menu, you are prompted for the input to view. The inputs are listed by wire tag. After selecting the desired input, the wire tag and the name of the input are scrolled across the top line of the display. The second line of the display shows the last logged voltage for that input. If the input has not been calibrated, or the calibration has been corrupted, the display will show “cal. corrupt” in place of the last logged voltage.

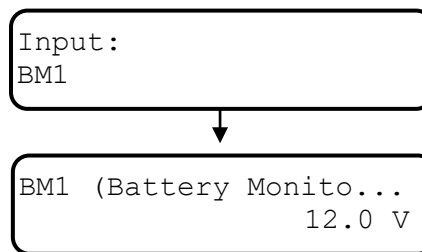

When “cal corrupt” comes up, ship the unit back to the factory for repair, re-calibration, and testing.

3.8.5 Monitoring Relay Outputs on the LUI

Using the LUI you can monitor *and control* the state of both Relay Outputs.

LUI display:



After selecting the Relay Output option you are prompted for which relay output to view. The relay outputs are listed by wire tag. The wire tag and name of the output are scrolled on the first line of the display as well as instructions on controlling the state of the output. The state name for the output’s present state is displayed on the second line. The state of the relay can be controlled from this view. The **0 (zero) key** turns OFF the displayed relay. The **1 key** turns ON the displayed relay. The **7 key** will PULSE the relay from its current state to the opposite state for the configured pulse time. The **8 key** will TOGGLE the relay at the configured duty cycle and toggle period.

3.8.6 Monitoring Network I/O on the LUI

Using the LUI you can monitor modules on the Echelon network.

LUI display:



3.8.7 Monitoring Field Communications on the LUI

Using the LUI you can monitor field communications on the Echelon network.

LUI display:

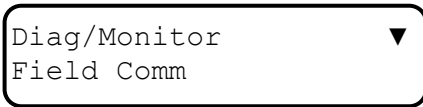

3.9 INCIDENT STORAGE

Terminal screen:

```
Main Menu > Incident Storage
```

LUI display:



The SEAR II is capable of storing 5 “snapshots” of the event buffer into its flash memory. Each snapshot is called an incident and can be up to 100 events in size. Each incident has a name, description, and a starting date/time. Since incidents are maintained in flash, a loss of power and internal backup battery will not corrupt or delete them.

Incidents may be added, deleted, or overwritten from the Terminal Interface or the LUI. The delete and overwrite operations are password protected with the supervisor password. Each event that is stored in flash is also given a 32-bit validation CRC that covers the event’s text string (not including white space, such as tabs and spaces). The seed for the event’s CRC is the CRC of the previous event. Therefore, events must not only be uncorrupted, but in correct order to be valid.

An incident can be printed or displayed and validated with a computer program that assures the integrity of the incident report, and verifies it has not been inadvertently modified or corrupted.

When the events are stored, the site name, milepost and DOT number are saved. If these items are later changed in the configuration, they will remain unchanged in the saved incident. Events are stored in their expanded text format for incidents. That means changing the tag or state names of an I/O channel will not change the text of events.

3.10 REPAIR HISTORY

Terminal screen:

```
Main Menu > Repair History
```

LUI display:

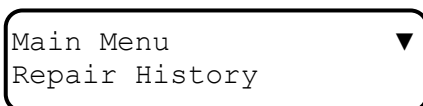

The SEAR II maintains a log of repairs, software upgrades, installed modules, application logic versions, and battery input calibrations. The repair history log is maintained as a 500 entry circular buffer in the system flash memory; therefore, the repair history cannot be lost by power loss or a bad backup battery.

Each entry into the repair history has a date/time stamp, type, and text string. When viewing repair history reports, the entries may be filtered by type.

Table 3-14 describes the types and when they are logged into the repair history.

Table 3-14. Repair History Entries

SETTING	DESCRIPTION
Init	<p>Logged the first time the repair history block is initialized. It is usually logged with an unknown time stamp.</p> <p>Unknown time Init Repair history initialized</p>
Exec S/W	<p>Logged on the first boot-up after an executive software upgrade. The new executive software version is shown in the log entry.</p> <p>1-01-2003 17:12:57 Exec S/W 9V645-A01.E</p>
APP S/W	<p>Logged after a new version of application logic software is downloaded into the unit. The new application logic version is shown in the log entry. An entry is also logged when the application program is removed.</p> <p>9-16-2003 11:06:21 APP S/W NS.001 9-18-2003 9:12:43 APP S/W APP REMOVED</p>
Factory	<p>Logged during the factory testing procedure. Items added during the procedure are logged with this type such as the calibrations of the battery inputs. An entry is also logged with this type when the factory tests are completed.</p> <p>5-23-2002 16:49:38 Factory Factory tests completed 10-05-2002 7:57:30 Factory Battery input 1 calibrated</p>
Module	<p>Logged when modules are installed, replaced or removed. When a module is installed into the network, an entry in the repair history is made with the module's name, node number, Neuron ID, and software version. When a module is removed or replaced, it is logged with the module's name.</p> <p>9-23-2003 15:43:31 Module DIO,2,01000a963600,9V147-A01.A 9-24-2003 10:23:37 Module Replaced DIO 9-24-2003 10:50:19 Module Removed DIO</p>
RTC	<p>Logged the first time the real-time clock is initialized. All entries in the repair history after and including this entry have a date/time stamp. Entries that occur previous to this entry have an unknown date/time stamp.</p> <p>16:15:03 5-22-2002 RTC RTC initialized</p>
Manual	<p>Logged by factory personnel. Factory personnel can manually enter any repair item into the history.</p> <p>8:53:35 6-04-2002 Manual Fixed bad input circuit for DI10</p>

3.11 PASSTHROUGH MODE

Terminal screen:

```
Main Menu > Passthrough
```

Passthrough mode takes all the serial data received on one serial port and transmits it on the other and vice versa. For example, you have a serial cable connected to the USER port and a laptop. You also have a serial cable connected between the AUX port and a GCP. The user can hit CTRL-L and get the usual terminal interface for the SEAR II. Without disconnecting or changing cables, you can access the GCP serial port by going into passthrough mode. Everything you type on the laptop will be sent out the AUX port to the GCP and everything the GCP sends will be sent out the USER port to the laptop. The passthrough mode is especially useful when a site has one modem. The modem can be connected to the USER port of the SEAR II and a Harmon HXP can be connected to the SEAR II AUX port. The user can dial in and get event logs and data from the SEAR II. Also, you can go into passthrough mode and access all the menus and information on the HXP. You can do all that remotely with only one modem and no need for serial switch hardware.

3.12 EVENT STREAM

Terminal screen:

```
Main Menu >Event Stream
```

LUI display:

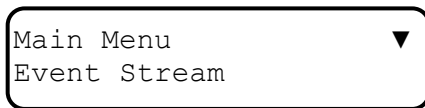

This option is used to test the SEAR II in real time. You can watch the display as a train moves and check the events that are reported.

3.13 CHANGING PASSWORDS

Terminal screen:

Main Menu > Change Password

LUI display:

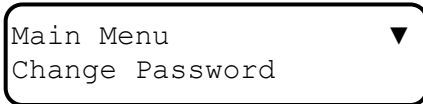

There are three separate passwords used to access various operational functions. Each password can be a maximum of ten digits (Alphanumeric and symbols) and is case sensitive. If passwords are used, certain data fields cannot be modified by unauthorized personnel. Passwords are available for Maintenance, Supervisor, and Siemens Rail Automation Personnel.

When the `Change Password` menu option is selected, you are prompted as to which password you wish to change. On the **Terminal Interface** use the left and right arrows to select between the three password selections, then press ENTER on the keyboard. On the **LUI** use the down and up arrows to make a selection, then press the ENTER key.

After selecting the type of password you wish to change, you are prompted to enter the old (current) password. If you do not enter the correct existing password exactly, you are immediately returned to the Main Menu.

Upon successfully entering the correct (old) password you are prompted to enter the new password. Enter the new password (up to ten digits) and press ENTER.



CAUTION

BE EXTREMELY CAREFUL WHEN ENTERING A NEW PASSWORD. YOU WILL **NOT** BE PROMPTED TO RE-ENTER YOUR PASSWORD FOR CONFIRMATION. WHATEVER YOU ENTER WILL BE ACCEPTED!!!

IF YOU FORGET YOUR PASSWORD, CONTACT SIEMENS RAIL AUTOMATION FOR ASSISTANCE.

3.14 VERSIONS

Terminal screen:

```
Main Menu > Versions
```

LUI display:

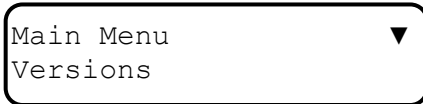

Selecting this option displays the current version of the system executive and the application software on this SEAR II.

3.15 APPLICATIONS

Terminal screen:

```
Main Menu > Applications
```

This feature is used to upload and download applications, or view the Compiler Log.

3.16 TESTS

Terminal screen:

```
Main Menu > Tests
```

LUI display:

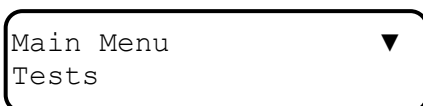

This function is dependent on the application.

This page intentionally left blank

APPENDIX A - INSTALLING FERRITE BEAD EMI FILTERS ON SEAR II CABLES

INSTALLING EMI FILTER ON POWER AND ECHELON® CABLES

In order to reduce radiated electromagnetic interference from the SEAR II, clamp-on EMI filters (part number Z590-00010-0001) must be installed on both the SEAR II power and Echelon cables. Two of the EMI filters are supplied with each SEAR II for this purpose. Install these filters on the power and Echelon cables as follows:

Step 1. Open the clamp-on EMI filter as shown in Figure A-1.



Figure A-1 Clamp-on EMI Filter (open)

Step 2. Place the open EMI filter under the cable approximately 1.5 inches from the stripped end of the wires.

Step 3. Wrap the long end of the cable around the outer surface of the filter and back through the center of the filter one time (totaling two wire runs inside the filter – see Figure A-2).



Figure A-2 EMI Filter Installation (showing wire loops)

Step 4. Snap the filter closed (see Figure A-3).



Figure A-3 EMI Filter Installed