

Apvd SH 5-22-95	ITEM	DESCRIPTION	PC. NO.	QTY.
	1	FUSIBLE SWITCH	CAT. NO. *	1
	2	VACU-BREAK BRANCH BUS	11-7025-01	3
	3	VACU-BREAK MOUNTING BRACKET	11-6043-01	4
	4	1/4-20 X 3/8 SHWSW	11-1553-02	8
	▲ 5	STRAP-BUS HARDWARE KIT	11-B-2022-05	1
	6	NEUTRAL LUG ASSEMBLY	12-B-2105-02	1
	7			
	8			
	9			
	10			
	11			
	12			
	13			
	14			
	15			
	16			
	17			
	18			
	19			
	20			
	21			
	22			
	23			
	24			
	25			
	26			
	27			
	28	SERIES 5 CONVERSION KIT	11-5570-01	1
	29	INSTRUCTION SHEET	31-1157-01	1
	30	CARTON LABEL	15-A-1027-01	1
	31	CARTON	48000989	1
	32			
	33			
	34			
	35			
	36	*VACU-BREAK CAT. NO. VB657		
	37	5" UNITS-FOR FUSIBLE SWITCH CAT NOS. :		
	38	V7B2211, V7B2212, V7B2222, V7B3211, V7B3212, V7B3222		
	39	7 1/2" UNITS-FOR FUSIBLE SWITCH CAT. NOS. :		
	40	V7E2223, V7E2233, V7E3223, V7E3233, V7E2611, V7E2612		
	41	V7E3611, V7E3612, V7E3622, V7E3623, V7E3633		
	42			
	43			
	44	MERCHANDISE KIT NO. VB657C		

Revisions: 0: 1B-90841E-166B 12-11-09
 1: 1C-831A 4-12-04
 2: 1C-831B 7-24-06
 3: 1E-053A 1-9-07

Chk SH 5-22-95
 By RAW 43

Confidential - property of Siemens Industry, Inc. Norcross, GA
 VACU-BREAK MOUNTING SERIES 5 & 6, CU. BRANCH BUS
 Title
 11-5073-03
 Dwg No.
 Sht. 1 Of 1
 4 Rev.

FOR USE WITH V/B 5.0", 7.5" TWIN UNITS ON SERIES 5 OR 6 DISTRIBUTION SECTIONS, CDP-5, CDP-6, VB-5, VB-6, FCI, FCII, SB1, SB2 & SB3.

IF EXISTING EQUIPMENT IS TYPE CDP-5, VB-5, OR FC20 THE VERTICAL BUS WILL BE PRE-PUNCHED WITH .406 DIAMETER HOLES, IN THESE CASES USE SERIES 5 ADAPTOR KIT FURNISHED WITH THIS KIT. SEE REVERSE SIDE FOR INSTRUCTIONS.

31-1157-01 Rev. 3

Siemens Industry, Inc. Norcross, GA

CAT. NO. VB657

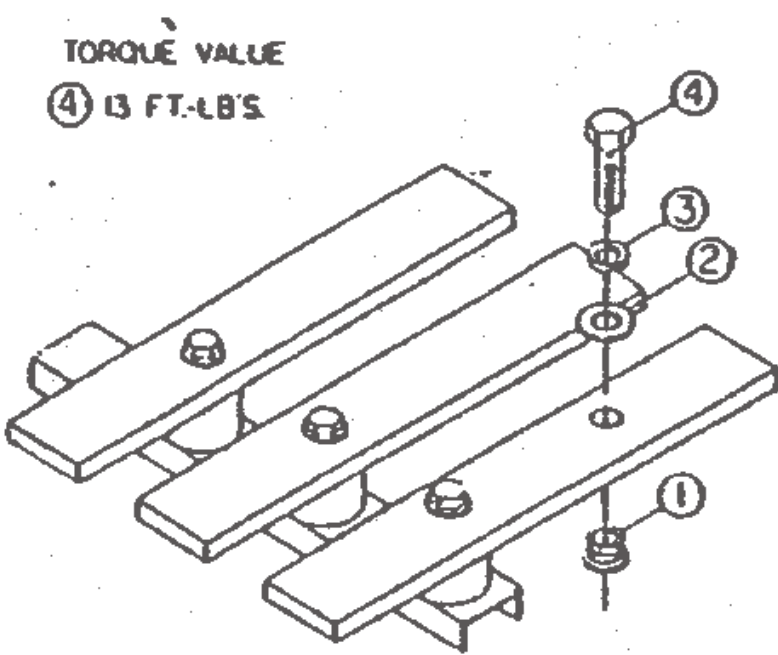

Apvd DSH 6-15-92	ITEM	DESCRIPTION	PC. NO.	QTY.
	1	5/16 INSERT	11-1620-04	6
	2	5/16 FLAT WASHER	11-1615-06	6
	3	5/16 LOCK WASHER	11-1618-04	6
	4	5/16-18 X 1 1/4 HHMS	11-1566-07	6
	5	FAST LATCH SCREW BAG	11-A-1821-01	1
	6 ▲	ID CARD	31-1160-01	1
	7			
	8			
	9			
	10			
	11			
	12			
	13			
	14			
	15			
	16			
	17			
	18			
	19			
	20			
	21			
	22			
	23			
	24			
	25			
	26			
	27			
	28			
	29			
	30			
	31			
	32			
	33			
	34			
	35	For use in adapting Series 6 Mounting Kits to be used in Series 5 type panel construction.		
	36			
	37	Series 5 construction has .406 dia. holes in interior horizontal bus.		
	38			
	39			
	40	(1) Use 5/16-18 insert in bus being certain that flange on insert is pulled up flush with back of bus bar.		
	41			
	42			
	43	(2) Drill out appropriate holes in branch bus minimum of .344 dia. to accommodate 5/16-18 bolts.		
	44			

Revisions: 0: 681
 1: 1B-362 6-5-92
 2: 1B-359 11-11-92
 3: 1C-286 4-19-99

Chk DSH 6-5-92
 By RM 43

Confidential - property of Siemens Industry, Inc. Norcross, GA
 SERIES 5 ADAPTOR KIT
 Title
 11-5570-01
 Dwg No.
 Sht. 1 Of 1
 3 Rev.

FOR USE WITH V/B 5.0", 7.5" TWIN UNITS ON SERIES 5 OR 6 DISTRIBUTION SECTIONS, CDP-5, CDP-6, VB-5, VB-6, FCI, FCII, SB1, SB2 & SB3.

IF EXISTING EQUIPMENT IS TYPE CDP-6, VB-6, FCI OR FCII THE VERTICAL BUS WILL BE PRE-PUNCHED WITH .228 DIAMETER HOLES. IN THESE CASES USE SERIES 6 BRANCH BUS PARTS LIST ON REVERSE SIDE.

CAT. NO. VB657