

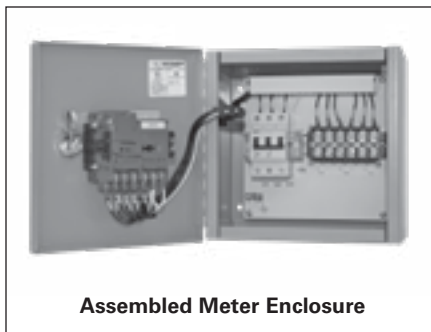

WinPM.Net



Powermanager Software



Assembled Meter Enclosure



Power Meters

Contents

Power Distributions Solutions

Power Distributions Solutions Introduction

Power Monitoring Systems Overview	8-2
Intelligent Metering and Control Devices	8-3

Power Meters

PAC2200	8-4
PAC3120	8-5
PAC3200T	8-6
PAC3220	8-7
PAC4200	8-8
9410	8-9
9810	8-10
Enclosed Meters	8-12
Branch Circuit Monitoring /SEM3 Embedded Metering	8-17
Enclosures for External Applications	8-21
MD Meter – BACnet MSTP/IP standalone meter	8-23
Low-voltage Current Transformers	8-24

Thermal Monitoring Solution

SEM3T	8-26
-------	------

Energy Management Software

Powermanager Software	8-32
WinPM.Net Software	8-33

Application Engineering

Digitalization for Smart Infrastructure	8-34
Services	8-35

Siemens recognizes that high performance facilities make for high performance business. Energy is the lifeline of your business, and better efficiency and sustainability can have a large positive impact on your bottom line.

Energy Management and Control Systems from Siemens are complete enterprise solutions that help you manage the energy costs and availability of your business. With our advanced meters and controls, you can be sure to use only the energy you need, when you need it.

Siemens Power Distribution Solutions contribute toward achieving LEED® certification and provides the needed energy metering data for federal/local government energy reductions programs.

Features and Benefits of Siemens Power Distribution Solutions:

- Power Quality Reliability & Analysis
- Utilities Cost Allocation & Billing
- Utilities Usage Aggregation
- Load Preservation
- Equipment Monitoring
- Facility Monitoring & Automation
- Sequence of Event Recording
- Preventative Maintenance
- Electrical Asset Management

Additional Products/Services

- Branch Circuit Monitoring
- Sub-Billing and Cost Allocation
- Application Engineering
- Services Agreements
- Network/Communication Components
- Integration with Existing
- SCADA/BAS Systems
- Incorporation of Third Party Devices

Totally Integrated Power

System Overview

General

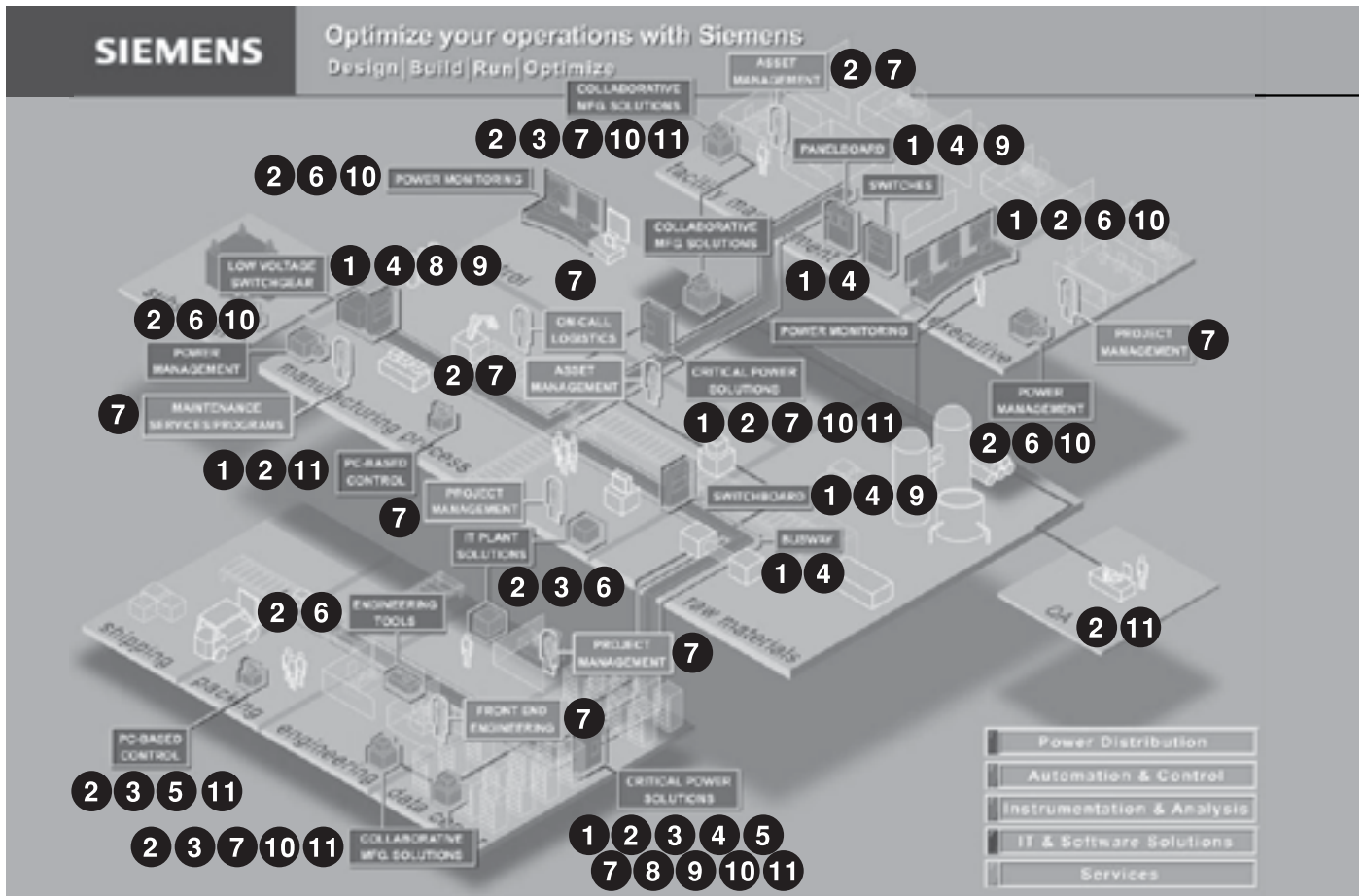

1. Power Meters

Siemens' ACCESS power monitors combine the best of new technologies and proven practices. Monitor critical loads, power quality, and demand via the web directly from the meters.

2. Power Monitoring Software

WinPM.Net web-enabled software facilitates easy, enterprise-wide connection to power monitoring equipment, circuit breakers, and other devices from Siemens and third parties. Access information via the web with unlimited no-cost clients using built-in WebReach™ via your web browser.

3. Communications Networks

Utilize existing Ethernet or RS-485 communications networks to extract the information you need and get it where it needs to go.

4. Components

Current Transformers (CTs), Voltage/Potential Transformers (PTs), Power Supplies, Ethernet Switches, Protocol Converters. Siemens can provide everything required for your system.

5. Intelligent I/O

Our S7 I/O enables plug-n-play communications with Modbus devices and expands digital and analog input and output functionality of ACCESS Systems.

6. Billing and Load Allocation Software

ACCESS Energy Manager is the low-cost, simplified solution for cost allocation, billing & load/demand analysis using your web browser.

7. Engineering Services

PDS Application Engineers can help from design through commissioning of even the most demanding power quality and monitoring systems.

8. Motor Control Centres

Monitor mains and feeders for critical or power-intensive loads. Communicate with breakers (Static Trip III, SBEC), SAMMS, SIMOCODE, I/O and devices from other manufacturers. Use ACCESS power meters to web-enable new as well as existing MCCs.

9. Low & Medium Voltage Switchgear

Web-enable switchgear by having ACCESS monitor power as well as breaker status and upload the information to a corporate Intranet or to the Internet. Use MeterMail™ directly from meters for alarm conditions or simple reporting.

10. Facility Management Systems

Tie into building automation systems to provide the required power and energy information. Lots of communications options are available ranging from legacy protocols to XML directly from the power monitors.

11. Distributed Control Systems, Automation, and SCADA/Human Machine Interface

ACCESS power monitors and/or software can talk to all major vendors' systems.

Intelligent Metering and Control Devices



	PAC2200	PAC3120	MD Meter	SEM3	PAC3200T	PAC3220	PAC4200	9410	9810
Power, Energy and Demand									
Voltage/current: per phase, average	■	■	■	■	■	■	■	■	■
Voltage/current: unbalance	■	■	■	■	■	■	■	■	■
Power: real(kW), reactive(kVAR), apparent(kVA), power factor, frequency	■	■	■	■	■	■	■	■	■
Energy: bi-directional, import, export	■	■	■	■	■	■	■	■	■
Energy kWh: total, net	■	■	■	■	■	■	■	■	■
Demand: block, sliding window	■	■	■	■	■	■	■	■	■
Demand: thermal predicted	■	■	■	■	■	■	■	■	■
Power Quality Analysis									
Sag(Dip)/Swell disturbances monitoring	■	■	■	■	■	■	■	■	■
Voltage disturbance direction detection	■	■	■	■	■	■	■	■	■
High speed transient capture	■	■	■	■	■	■	■	■	■
Harmonics (individual, even, odd, total) up to		THD only			THD only	THD only	63rd	63rd	10MHz 63rd
Sampling rate, maximum samples/cycle	135k	135k		60	135k	135k	204	256	1024
Flicker, harmonics to EN50160, IEC 6100-4-7 / 4-15	■	■	■	■	■	■	■	■	■
Configurable for IEEE 519-2014, SEMI/ITIC	■	■	■	■	■	■	■	■	■
Data and Waveform Logs									
Triggered by setpoint, schedule, or external signal	■	■	■	■	■	■	■	■	■
Sequence-of-event logs or alarm logs, variable log depth	■	■	■	■	■	■	■	■	■
Minimum/maximum logs	■	■	■	■	■	■	■	■	■
Onboard Historical logging Memory	③	③		8GB (6 mos.)	③	③	④	320MB	2GB
Email data and event logs	■	■	■	■	■	■	■	■	■
Waveform recording	■	■	■	■	■	■	■	■	■
Waveform in COMTRADE format with FTP	■	■	■	■	■	■	■	■	■
GPS time synchronization	NTP/SNTP			NTP	NTP/SNTP	NTP/SNTP	SNTP	NTP/SNTP	NTP/SNTP
Time-stamps, resolution in seconds	±1 sec			1 min	±1 sec	±1 sec	±0.1 sec.	±0.1 msec.	±0.1 msec.
Time synchronization - IEEE1588/IEC61588/PTP	■	■	■	■	■	■	■	■	■
Communication Ports, Protocols and I/O									
() = Optional									
USB ports			1						2 (not activated)
RS-485-only ports	(1)	1	1	1		(1)	(1)	1	2
Ethernet ports	(1)		(1)	1	1	2	1	2 (UTP)	2 (UTP)
PROFIBUS ports						(1)	(1)		
PROFINET ports						(2)	(2)		
Modbus RTU Slave on serial	■	■	■	■		■	■	■	■
Modbus RTU Master on serial ports									
Modbus/TCP on Ethernet ports	■		■	■	■	■	■	■	■
Modbus TCP Master over Ethernet									
BACnet MS/TP			■	■					
BACnet IP on Ethernet ports			■	■					
SNMP				■				■	■
DNP 3								■	■
IEC 61850								■	■
DHCP	■			■	■	■	■	■ (IP v4/IP v6)	■ (IP v4/IP v6)
RSTP								■	■
Secure protocols (HTTPS, SFTP, SSH, Secure Modbus)								HTTPS	HTTPS
Ethernet Gateway: 31 other meters accessible via RS-485							■		
Multiple masters over Ethernet			2	4	3	3	3	8	8
On-board web server - Realtime, Trending	■			■ (CSV output)	■	■	■	■	■
On-board web server - Waveform display									
Analog inputs						(1)	(1)	(16)	(16)
Analog outputs								(8)	(8)
Digital status/counter inputs (standard/optional add-ons)	1	2		2/(44)	1	2 / (8)	2 / (8)	3 / (24)	8 / (24)
Digital relay outputs (control/pulse)	1	2	1	1	1	2 / (4)	2 / (4)	1 / (8)	4 FA/2RO (8RO)①
Integrated display	B/W	B/W	B/W	Opt. Color		B/W	B/W	Color	Color
Setpoints, Alarming and Control									
Setpoints, minimum response time		■	■	■	■	■	■	1/2 cycle	1/2 cycle
Math, logic, trig, log, linearization formulas		and/or, ><		Grouping	and/or, ><	and/or, ><	and/or, ><	■	■
Multi-condition alarms		■			■	■	■	■	■
Email on alarm								■	■
Revenue metering									
ANSI C12.1 accuracy compliant	1.0							■	■
ANSI C12.20		0.5	0.2	0.2	0.5	0.5	0.2	0.2②	0.2
EN50160 Compliance Reporting								■	■ (Ed4)
IEC 61000-4-30 Class A/S								■ (Class S Meter)	■ (Class A Ed3)
IEC 61577-12 accuracy compliant	1.0	0.5			0.5	0.5			
IEC 62053-22 replaces IEC 60687 0.2S compliant	■	■		■		■	■		■ (0.1S)
IEC 62053-23, 24 compliant for Reactive Energy accuracy	■	■				■			■ (0.25)
IEC 62586-1 (new Power Quality standard)									■
IEC 60687 accuracy class compliant	■ (1.0)	■ (0.5)		■ (0.2)	■ (0.5)	■ (0.5)	■ (0.2)	■ (0.2)	■ (0.2)
ANSI class 10, IEC 1/10 (1A nominal, 10A max)									■
ANSI class 20, IEC 5/20 (5A nominal, 20A max)									■
Time-of-use	■	■			■	■	■	■	■

Some Features are optional, Refer to datasheets for allowable port configurations. Products meet or exceed the accuracy requirements of the standards listed; due to form factors, not all ANSI/IEC compliance tests may apply. Some products certified by third party laboratory.

① FA - Form A contact output, RO - Relay output.

② This meter is 0.2S compliant at 5A nominal CT, and 0.5S compliant at 1A nominal CT.

③ Load profile kWh/day for 63 days. kWh/month for 24 months.

④ Load profile kWh/15min values for 40 days.

PAC2200 Power Meter

General

Reliable and Precise Monitoring of Electrical Power Systems

The **PAC2200** is a powerful compact din rail mounted power monitoring device that is suitable for use in industrial, government and commercial applications where basic metering and energy monitoring is required. The meter may be used as a standalone device monitoring over 50+ parameters or as part of an industrial control, building automation or global power monitoring system. Metering and monitoring applications range from simple analog volt and amp meter replacements to stand-alone cost allocation installations with multiple tariffs.

The PAC2200 provides open communications using Modbus RTU/TCP, and Mbus protocols for easy integration into any local or remote monitoring system. With a built-in web server viewing your data has never been easier. Simple configuration of the meter can be done from the front display or by using a PC with SENTRON powerconfig setup free software available for download from SIEMENS website.

Precision

- ANSI C12.1 Class 1
- Energy Measurement
 - Voltage +/- 0.5%
 - Current +/- 0.5%
 - Power Factor +/- .5%
 - Sampling Rate 135K/per cycle
- Revenue Accurate
 - Cost Allocation
 - MID Certified variant for European customers
- Cost Effective

Energy Management

- Serves three masters via the TCP connection
- Energy Consumption
- Automation Integration
- Solution for LEED® credit
- Monitors Critical Equipment
- Modbus TCP/RTU
- Mbus

Reliability

- Economical Measurement
 - Commercial
 - Industrial
 - Residential
- Degree of Protection
 - Front – IP40
 - Rear – IP20
- 480V Connected Voltage
- Simple Retrofit Installation
- Integration with Existing Systems

97 mm [3.8 in]
108 mm [4.2 in]
71 mm [2.8 in]

Condensed LCD Display to indicate:

- Display title or designation of the displayed measurements
- Phase
- Measured value
- Unit
- Labeling of function keys

Example of operating menu:

The texts can be displayed in several languages, which can be selected directly on the device.① The condensed graphic LCD display facilitates reading even from a distance. For optimum visibility even in poor light conditions the PAC2200 comes with a gradually adjustable background illumination.

Order information

Product	Catalogue Number
PAC2220 Modbus RTU, L-L: 400 V, L-N: 230 V, 5 Amp, self-powered, screw terminals	7KM22002EA301DA1
PAC2220 Modbus TCP, L-L: 400 V, L-N: 230 V, 5 Amp, strd rail instr, self-powered, screw terminals	7KM22002EA301EA1
PAC2220 Modbus RTU, MID Certified, L-L: 400 V, L-N: 230 V, 5 Amp, self-powered, screw terminals	7KM22002EA301HA1
PAC2220 Modbus TCP, MID Certified ,L-L: 400 V, L-N: 230 V, 5 Amp, self-powered, screw terminals	7KM22002EA301JA1

① Languages included as standard in the meter are English, German, French, Spanish, Italian, Portuguese, Turkish, Russian and Chinese.

PAC3120 Power Meter

Basic Monitoring of Electrical Power Systems

The **PAC3120** is a powerful compact power monitoring device that is suitable for use in industrial, government and commercial applications, where basic metering and energy monitoring is required. The meter may be used as a stand alone device monitoring over 100+ parameters or as part of an industrial control, building automation or global power monitoring system. Metering and monitoring applications range from simple analog volt and amp meter replacements to stand-alone cost allocation installations.

The PAC3120 has many features not usually found in this price class of meters. A large graphical display supports multiple languages and easy to use menus that can be used to set up the meter. The meter also has built in Modbus RTU communications via a RS485 interface. The meter comes standard with two digital inputs and two digital outputs. One output is suitable for pulse output for export/import real and reactive energy. The other output is controllable from an outside source by way of a Modbus register.

Precision

- ANSI C12.20 class 0.5
- Energy Measurement
 - Voltage +/- 0.2%
 - Current +/- 0.2%
 - Power Factor +/- 0.5%
 - Sampling Rate 135k/per cycle
- Revenue Accurate
 - Cost Allocation
- Cost Effective

Energy Management

- Energy Consumption
- Demand Control
- Automation Integration
- Solution for LEED® credit
- Monitors Critical Equipment
- Sub Metering

Reliability

- Economical Measurement
 - Commercial
 - Industrial
 - Residential
- Degree of Protection
 - Front – IP65
 - Rear – IP20
- 480V Connected Voltage
- Simple Retrofit Installation
- Integration with Existing Systems

96 mm [3.78 in.]

96 mm [3.78 in.]

Full Graphic LCD Display to indicate:

- Display title or designation of the displayed measurements
- Phase
- Measured value
- Unit
- Labeling of function keys

Example of operating menu

With an easy-to-read adjustable back lit LCD display, the PAC3120 can be commissioned in only two steps. After selecting the language and setting two parameters (voltage and current inputs), the meter is ready for use.Ⓞ

Order information

Product	Catalogue Number
PAC3120 Compression terminals AC/DC	7KM31200BA011DA0
PAC3120 Compression terminals DC Only	7KM31201BA011EA0
Adapter Plate for 4700/4720 meter cutout	93-47ADAPTER
PAC32/4200 Meter DIN Rail adapter – Meter display will not be seen	7KM9900-0YA00-0AA0
PAC32/4200 Meter DIN Rail 2-adapter – Meter display will not be seen	7KM9900-0XA00-0AA0

Ⓞ Languages included as standard in the meter are English, German, French, Spanish, Italian, Portuguese, Turkish, Russian and Chinese.

PAC3200T Power Meter

General

Reliable and Precise Monitoring of Electrical Power Systems

The **PAC3200T** is a powerful compact din rail mounted power monitoring device that is suitable for use in industrial, government and commercial applications where basic metering and energy monitoring is required. The meter may be used as a standalone device monitoring over 100+ parameters or as part of an industrial control, building automation or global power monitoring system. Metering and monitoring applications range from simple analog volt and amp meter replacements to stand-alone cost allocation installations with multiple tariffs.

The PAC3200T provides open communications using Modbus TCP protocol for easy integration into any local or remote monitoring system. With a built-in web server viewing your data has never been easier. Simple configuration of the meter can be done by using a PC with SENTRON powerconfig setup free software available for download from SIEMENS website.

Precision

- ANSI C12.20 Class 0.5s
- Energy Measurement
 - Voltage +/- 0.5%
 - Current +/- 0.5%
 - Power Factor +/- .5%
 - Sampling Rate 135K/per cycle
 - Total Harmonic Distortion (THD)
- Revenue Accurate
 - Cost Allocation
- Cost Effective

Energy Management

- Serves three masters via the TCP connection
- Energy Consumption
- Automation Integration
- Solution for LEED® credit
- Monitors Critical Equipment
- Modbus TCP/RTU

Reliability

- Economical Measurement
 - Commercial
 - Industrial
 - Residential
- Degree of Protection
 - Front – IP40
 - Rear – IP20
- 480V Connected Voltage
- Simple Retrofit Installation
- Integration with Existing Systems



Order information

Product	Catalogue Number
PAC3200T DIN Rail Mount Power Meter without DISPLAY, AC/DC, Modbus TCP, L-L: 400 V, L-N: 230 V, 5 A, wide-range pwr sup. unit AC/DC, screw terminals	7KM32000CA011AA0

Ⓢ Languages included as standard in the meter are English, German, French, Spanish, Italian, Portuguese, Turkish, Russian and Chinese.

PAC3220 Power Meter

General

Reliable and Precise Monitoring of Electrical Power Systems

The **PAC3220** is a powerful compact power monitoring device that is suitable for use in industrial, government and commercial applications where basic metering and energy monitoring is required. The meter may be used as a stand alone device monitoring over 100+ parameters or as part of an industrial control, building automation or global power monitoring system. Metering and monitoring applications range from simple analog volt and amp meter replacements to stand-alone cost allocation installations with multiple tariffs.

The PAC3220 provides open communications using Modbus RTU/TCP, PROFIBUS-DP, and PROFINET protocols for easy integration into any local or remote monitoring system. With a built-in web server viewing your data has never been easier. Simple configuration of the meter can be done from the front display or by using a PC with SENTRON powerconfig setup free software available for download from SIEMENS website.

Precision

- ANSI C12.20 Class 0.5s
- Energy Measurement
 - Voltage +/- 0.2%
 - Current +/- .2%
 - Power Factor +/- .5%
 - Sampling Rate 135K/per cycle
 - Total Harmonic Distortion (THD)
- Revenue Accurate
 - Cost Allocation
- Cost Effective

Energy Management

- Serves three masters via the TCP connection
- Energy Consumption
- Automation Integration
- Solution for LEED® credit
- Monitors Critical Equipment
- Modbus TCP/RTU
- Industrial Systems
 - PROFIBUS
 - PROFINET

Reliability

- Economical Measurement
 - Commercial
 - Industrial
 - Residential
- Degree of Protection
 - Front – IP65
 - Rear – IP20
- 600V Connected Voltage
- Simple Retrofit Installation
- Integration with Existing Systems



96 mm [3.78 in.]

96 mm [3.78 in.]

Full Graphic LCD Display to indicate:

- Display title or designation of the displayed measurements
- Phase
- Measured value
- Unit
- Labeling of function keys



Example of operating menu:

The texts can be displayed in several languages, which can be selected directly on the device. The large graphic LCD display facilitates reading even from a distance. For optimum visibility even in poor light conditions the PAC3220 comes with a gradually adjustable background illumination.



Example of Optional Expansion Module install

Order information

Product	Catalogue Number
PAC3220 compression terminals (not suitable for use with ring tongue terminals), AC/DC	7KM32200BA011DA0
PAC3220 compression terminals (not suitable for use with ring tongue terminals), DC only	7KM32201BA011EA0
Expansion Module - PAC PROFIBUS DP	7KM93000AB010AA0
Expansion Module - PAC PROFINET	7KM93000AE020AA0
Expansion Module - PAC MODBUS RTU	7KM99000XA000AA0
Expansion Module - I(N), I(Diff), Analog for PAC 3220 or 4200	7KM92000AD000AA0
PAC3220/4200 Meter DIN Rail adapter – Meter display will not be seen	7KM99000YA000AA0
PAC3220/4200 Meter DIN Rail 2-Tier adapter – Meter display will not be seen	7KM99000XA000AA0
Power Supply. Input: 120-230V AC / 110-300V DC Output: 24 V DC 4 Amps. DIN Rail mounted.	US2:PWRSFP4A
Adapter Plate for 4700/4720 meter cutout	93-47ADAPTER

① Languages included as standard in the meter are English, German, French, Spanish, Italian, Portuguese, Turkish, Russian and Chinese.

PAC4200 Power Meter

Reliable and Precise Monitoring of Electrical Power Systems

The **PAC4200** is a feature packed power monitoring device that is suitable for use in industrial, government and commercial applications where basic to advanced metering, logging, and I/O is required. The meter may be used as a stand alone device monitoring over 200 parameters or as part of an industrial control, building automation or global enterprise wide monitoring system.

Advanced power quality monitoring and logging applications range from single low-voltage breaker / building metering to sub-station main feeder monitoring, cost allocation installations with multiple tariffs. Whether your goal is to reduce operation cost, reduce your carbon footprint or to maintain

your power assets, the PAC4200 meter should be an important part of your power monitoring system.

The PAC4200 provides open communication using the standard built-in Ethernet Modbus TCP and has the capability of communicating through Optional Modbus RTU, PROFIBUS-DP, and PROFINET protocol modules simultaneously. This allows for easy integration into any local or remote monitoring system. With a built-in web server viewing your data has never been easier. The gateway functionality of this device reduces installation cost by replacing other gateway devices and simplifying wiring.

Precision

- ANSI C12.20 Class .2s
- Energy Measurement
 - Voltage +/- .2%
 - Current +/- .2%
 - Power Factor +/- .5%
 - Sampling Rate 204/per cycle
 - Individual Harmonics up to 63rd
- Power Quality
- Revenue Accurate
 - Cost Allocation
- Cost Effective

Energy Management

- Serves three masters via the TCP connection
- Energy Consumption
- Min/Max and Event Logs
 - Storage Capacity 40 days at 15 min intervals
 - Event Logging 4000 events
- Demand Control
- Automation Integration
- Modbus Gateway
- Modbus TCP/RTU
- Industrial Systems
 - PROFIBUS
 - PROFINET

Reliability

- Monitors Critical Equipment
- Economical Measurement
 - Commercial
 - Industrial
- Degree of Protection
 - Front – IP65
 - Rear – IP20
- 600V Connected Voltage
- Customizable Displays
- Simple Retrofit Installation
- Integration with Existing Systems
- Solution for LEED® credit

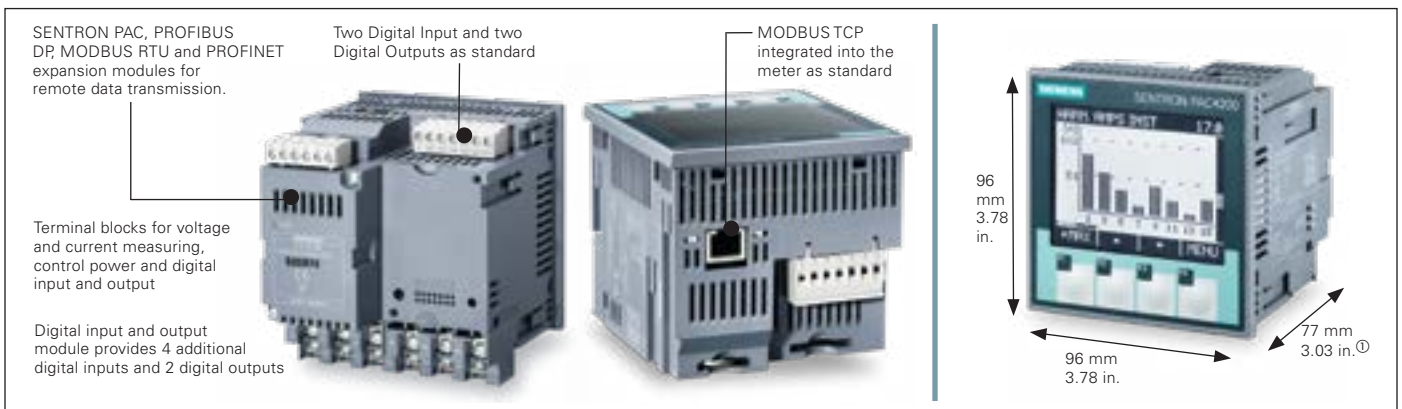

Order information

Product	Catalogue Number
PAC4200 compression terminals (not suitable for use with ring tongue terminals), AC/DC	7KM42120BA003AA0
PAC4200 compression terminals (not suitable for use with ring tongue terminals), DC only	7KM42111BA003AA0
Expansion Module - PAC PROFIBUS DP	7KM93000AB010AA0
Expansion Module - PAC PROFINET	7KM93000AE020AA0
Expansion Module - PAC MODBUS RTU	7KM99000XA000AA0
Expansion Module - PAC additional I/O	7KM92000AB000AA0
Expansion Module - I(N), I(Diff), Analog for PAC 3220 or 4200	7KM92000AD000AA0
PAC3220/4200 Meter DIN Rail adapter – Meter display will not be seen	7KM99000YA000AA0
PAC3220/4200 Meter DIN Rail 2-Tier adapter – Meter display will not be seen	7KM99000XA000AA0
Power Supply. Input: 120-230V AC / 110-300V DC Output: 24 V DC 4 Amps. DIN Rail mounted.	US2:PWRSP4A
Adapter Plate for 4700/4720 meter cutout	93-47ADAPTER

① 99mm, 3.90 in., with expansion module

9410 Web-Enabled Power Quality & Analysis Meter

Reliable and Precise Monitoring of Electrical Power Systems

The 9410 series meters are ideally suited to local and remote monitoring of low or high-voltage electrical installations in industrial facilities, commercial buildings, utility networks or critical power environments. Facility and operations personnel will benefit in energy-related costs while avoiding power quality conditions that can reduce equipment life and productivity.

The 9410 series meter is easy to install and use, offering integrated or remote high-visibility displays. A range of expansion modules help match features to the application and support field-upgrading of meters as required. Serial and Ethernet communication enable the meter to be used within a WinPM.Net power management system or with third-party management systems.



Precision

- ANSI C12.20 Class 0.2s
 - Energy Measurement
 - Voltage +/- .1%
 - Current +/- .1%
 - Power Factor +/- .5%
 - Sampling Rate 256/ per cycle
 - Individual Harmonics up to 63rd
 - Sags / Swells Detection
 - Programmable Math / Logic Function
- Revenue Accurate
 - Sub Billing
 - Cost Allocation

Energy Management

- Energy Consumption
- 9410 Waveform Capture
- Customizable Webpages
- Min/Max and Event Logs
- Demand Control
- Automation Integration
- Solution for LEED® credit
- Monitors Critical Equipment
- Modbus Gateway
- Modbus TCP/RTU
- Modbus Master
- Industrial Systems
- IEC 61850 Protocol

Reliability

- Economical Measurement
 - Commercial
 - Industrial
- Degree of Protection
 - Front – IP54, UL type 12
 - Rear – IP30
- 600V Connected Voltage
- Customizable Displays
- Email Alarms through Ethernet
- Field Addable Modules
- Simple Retrofit Installation
- Integration with Existing Systems

Order information

Product	Catalogue Number
9410DC measurement Canada approved and sealed	9410DCANS
9410DC measurement Canada approved	9410DCAN
9410 Panel meter with integrated colour display, 1 DO, 3 DI, dual port Ethernet	9410DC
9410 DC Powered Panel meter with integrated color display, 1 DO, 3 DI, dual port Ethernet, 20Vdc-60Vdc PS	9410D24VDC
9410 DC Powered DIN transducer meter packaged with remote display (includes 3m cable), 20Vdc-60Vdc PS	9410R24VDC
9410 DC Powered Meter without display (DIN rail mount transducer version) with 1 DO, 3 DI, dual port Ethernet, 20Vdc-60Vdc PS	9410T24VDC
9410 DIN transducer meter packaged with remote display (includes 3m cable)	9410RC
9410 Meter without display (DIN rail mount transducer version) with 1 DO, 3 DI, dual port Ethernet	9410TC
Accessories	Catalogue Number
9410 Remote colour LCD display, 96 mm x 96 mm, with 3 m cable	948DISP96
9410 I/O Module with 2 relay outputs, and 6 digital inputs (wetted)	948M2DO6DI
9410 I/O Module, 2 analog outputs (4 - 20 mA, 0- 10 VDC), and 4 analog inputs (4 - 20 mA, 0 - 30 VDC)	948M2AO4AI
9410 Voltage and Current Sealing Kit (included with base meter)	9410SK
9410 Remote display cable, 10 meters	948DCAB10
9410 Remote Display Mounting Adapter kit for 4" round hole - requires 9410RC	94PMAK
9410 Replacement hardware kit for 9410 meter	94PMHWK
9410 Replacement hardware kit for remote display	94PMRDHWK
9410 24Vdc Meter replacement hardware kit for remote display	94PMHWKDC

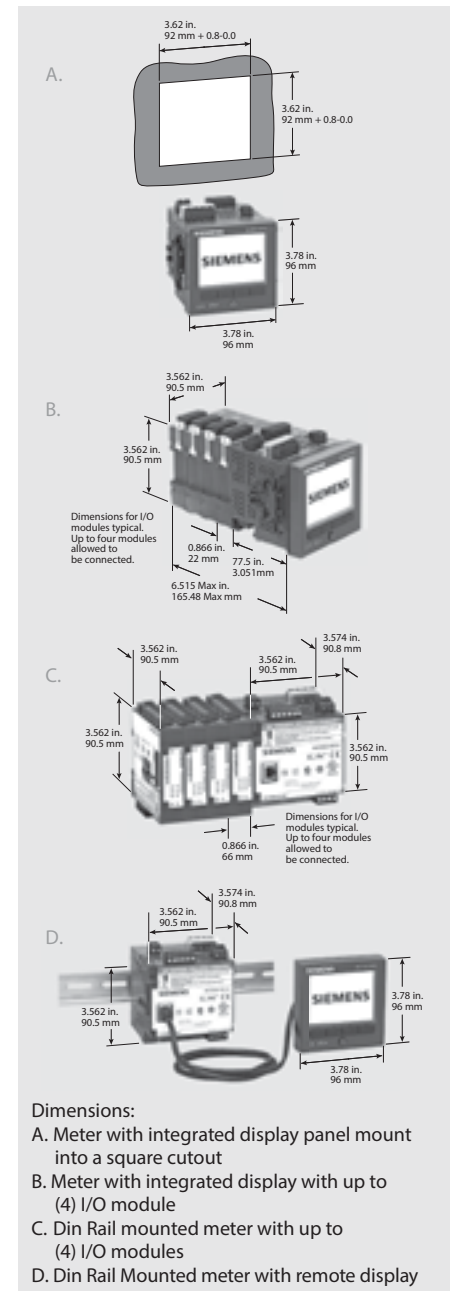

9810 Power Quality Meter and Analysis Meter

Power Quality Meter with Web Server Technology

The Siemens 9810 series high accuracy and advanced power quality meter combines accurate; 3-phase energy and power measurement with data logging, power quality analysis, e-mail, alarming, Modbus mastering, Transient detection, Disturbance Direction Detection (DDD), Pre-Event/Post-Event Waveform capture and extensive I/O capabilities in a highly flexible and modular format. Analysis results are captured in the event log, along with a time-stamp and confidence level indicating level of certainty. The 9810 base meter includes 8 digital inputs capable of providing ± 1 millisecond time stamping and 4 digital outputs. The 9810 meters support numerous protocols including Modbus, ION, DNP3, IEC 61850, HTTP, HTTPS, DLMS, FTP, SNMP, SMTP, DPWS, RSTP, PTP, NTP/SNTP, GPS, Syslog, and DHCP protocols.

Fast sampling rates and extensive memory make this the perfect choice for critical power systems making analysis of issues possible for correction and prevention. As a data accumulator, the 9810 meter can also save money and time by simplifying wiring and networking. Information from the meter and downstream devices can be displayed on the large capacitive 7" touch display or smaller 3.5" display, on customizable web pages in reports and screens.

Applications for the 9810 meter range from critical power applications such as data centers to industrial, commercial and government power and power quality monitoring systems. The 9810 meter is offered in a number of forms from single meter enclosures integrated into Siemens switchgear, switchboard and panelboards. Place this high end power quality meter throughout the power distribution system where critical information is desired. Know what is happening in your facility and get maximum efficiency.

Precision

- ANSI C12.20 Class .1s
- Energy Measurement
 - Voltage +/- .1%
 - Current +/- .1%
 - Power Factor +/- .5%
 - 9810 Sampling Rate
1024 samples per cycle
 - 9810 Individual Harmonics
up to 63rd
 - Sags / Swells Detection
 - Programmable Math /
Logic Function
- Revenue Accurate
 - Cost Allocation

Reliability

- Economical Measurement
 - Commercial
 - Industrial
- 600V Connected Voltage
- Email Alarms
- Customizable Displays
- Password Protected
- Hardware Lockable
- Supports Copper Ethernet
- Integration with Existing Systems



Energy Management

- Energy Consumption
- Waveform Capture
- Transient Capture 17 μ s @ 60 Hz
- Disturbance Direction Detection (DDD)
- Customizable Webpages
- Extensive data logging, trending and forecasting
Non-volatile on-board logging of min/max values, energy and demand, maintenance data, alarms, and any measured parameters. Trending and short-term forecasting of energy, demand, and measured parameters.
- Demand Control
- Automation Integration
- Monitors Critical Equipment
- Modbus Master / Gateway
- Supports Multiple Protocols
- Supports Multiple Master via Ethernet

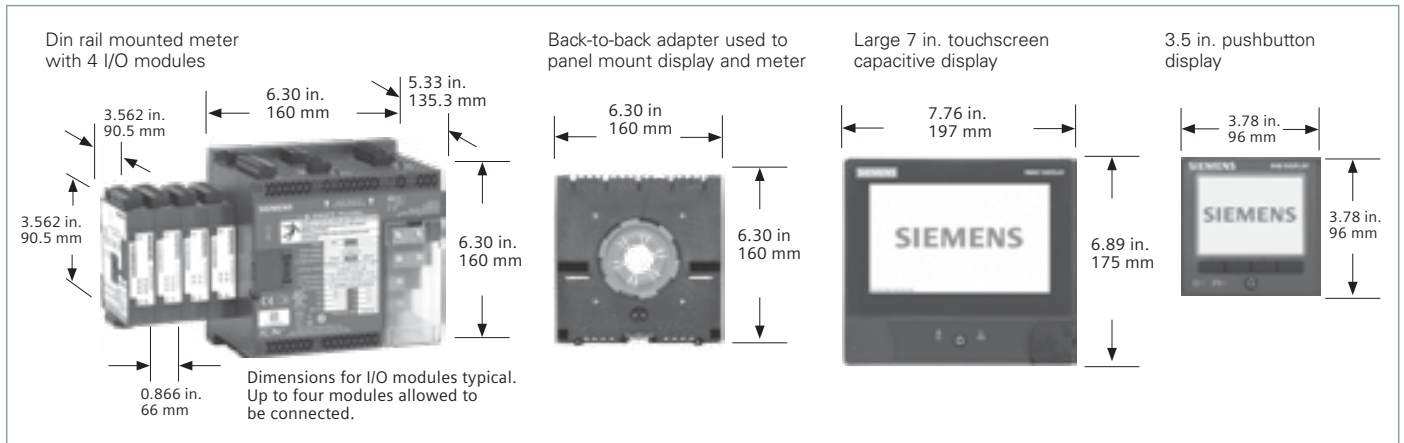

9810 Power Quality Meter and Analysis Meter

Order information

Product	Catalogue Number
9810 with 7" display (either din rail or panel mount)	9810RC
9810 without display	9810TC
9810RC 24VDC DIN transducer meter packaged with remote display, LVDC power supply (includes B2B adapter and 3m cable)	9810R24V
9810TC 24VDC Meter without display, LVDC power supply	9810T24V
9810RC LVCS DIN transducer meter packaged with remote display, LVCS current input (includes B2B adapter and 3m cable)	9810RCLVCS
9810TC LVCS Meter without display, LVCS current input	9810TCLVCS
9810RC LVSC 24VDC DIN transducer meter packaged with remote display, LVDC power supply, LVCS current input (includes B2B adapter and 3m cable)	9810RLVCS24V
9810TC LVSC 24VDC Meter without display, LVDC power supply, LVCS current input	9810TLVCS24V
Accessories	Catalogue Number
Large 7" display	9810R7DISP
Small 3.5" display + 3M cable	948DISP96
Remote display cable 10 M	948DCAB10
Remote display hardware kit	9810PMRDHWK
Expansion Modules	Catalogue Number
I/O Module-Digital (6IN/2OUT)	948M2DO6DI
I/AI Module-Analog (4IN/2OUT)	948M2AO4AI
Miscellaneous	Catalogue Number
9810 Hardware Kit	9810PMHWK
9810 LVCS Hardware Kit	9810LVCSHWK
9810 Back to Back adapter	9810BBADAPTER
9810 Current Input Green Connectors Hardware Kit.	9810CTHWK
9610/9510/ADR to 9810 mounting adapter	9810MADAPTER

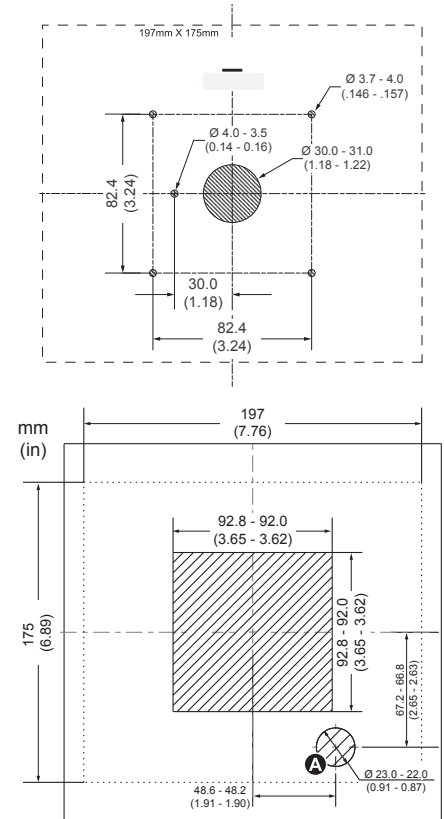

Electrical Characteristics

Measurement accuracy	Current and voltage	Class 0.1 as per IEC 61557-12
	Active power	Class 0.1 as per IEC 61557-12
	Power factor	Class 0.5 as per IEC 61557-12
	Frequency	Class 0.02 as per IEC 61557-12
	Active energy	Class 0.1S IEC 62053-22 (In=5A)
	Reactive energy	Class 0.1 IEC 61557-12, ANSI C12.20 Class 0.1 Class 0.5S IEC 62053-24
Data update rate	1/2 cycle or 1 second	
Input-voltage characteristics	Specified accuracy voltage	57 VLN/100 VLL TO 400 VLN/690 VLL
	Impedance	5MΩ per phase
	Specified accuracy frequency	42 to 69Hz (50/60Hz nominal)
	Limit range of operation -frequency	20 to 450Hz
Input-current characteristics	Rated nominal current	1A (0.1S), 5A (0.1S), 20A (0.1ANSI)
	Specified accuracy current range	Starting Current: 1mA (No Accuracy) Accurate Range: 10mA-20A
	Permissible overload	500A rms for 1s
	Impedance	0.0003Ω per phase
	Burden	0.01 VA max at 5A
Power supply	AC	90-480V AC ±10% (50/60Hz ± 10%), 90-120V AC ±10% (400Hz)
	DC	110-480V DC ±15%
	Ride-through time	100 ms (6 cycles at 60Hz) typical, 120V AC 400 ms (24 cycles at 60Hz) typical, 240V AC 1200 ms (72 cycles at 60Hz) typical, 480V AC
	Burden	Meter Only: 16.5W/38 VA max at 480V AC (50/60 Hz) Fully optioned meter: 40W/80 VA max at 480V AC (50/60 Hz)
	Input/outputs	Meter Base Only
	Optional	Digital - 6 form A digital inputs (30V AC/60V DC) 8 A at 250V AC or 5A at 24V DC) Analog - 4 analog inputs (4-20mA, 0-30V DC) +2 analog outputs (4-20mA 0-10V DC)

Mechanical Characteristics

Weight	DIN rail mounted Model 1.5 kg
	I/O modules 0.140 kg
	7" Touchscreen display: 0.861 kg
IP degree of protection	3.5" Display: 0.300 kg
	IP 65, UL type 12: Panel mount and touchscreen display, front.
	IP 30: Panel mount rear, DIN rail mount, I/O modules.

Dimensions	Panel mount model: Color remote display (2 options): 197 x 175 x 27.5 mm touchscreen 96 x 96 x 27 mm pushbutton	160 x 160 x 135.3 mm
	DIN model	160 x 160 x 135.3 mm
	I/O modules	90.5 x 90.5 x 22 mm
	Touchscreen Display(s)	192 mm and 96 mm

Enclosed Meters

Convenience and Reliability with Siemens Meter Enclosures

For economical and simple monitoring solutions, turn to Siemens metering units. Installed in rugged NEMA enclosures, these metering units are ideal for;

- Property Management Firms
- Malls
- Government Applications
- Food Courts
- Universities
- Building Retrofits
- Corporate Facilities
- High Rise Condos

The Siemens Meter Enclosure solution is shipped with all the required components pre-installed prior to shipment. The control voltage / voltage taps are wired to a protection device for safety of the meter and wiring and to provide a disconnect from outside power to the meter. Since safety is paramount, the meter CT connections are wired out to shorting blocks and shipped shorted. The enclosure also has a ground lug for equipment grounding. When the control voltage is greater than 240 volts, a CPT is provided between the breaker and the meter.

Siemens will be offering its Enclosed Meter solutions with all of its major Power Meter Options. The following options will be available for selection and application:

Enclosure Types:*

- NEMA 1
- NEMA 3R
- NEMA 12

Power Meter Series:

- PAC Meter Series **
- 9410 Meter Series
- 9810 Meter Series
- SEM3 - Embedded Metering Solution



NEMA 1 Enclosure Metering Solution

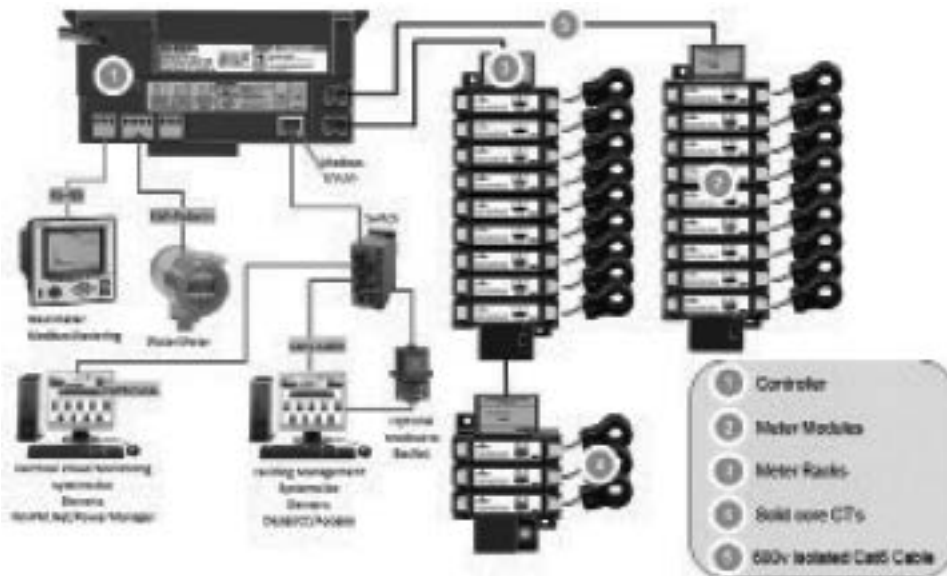

* NEMA 4X Enclosure option is available on special requests.
 ** Includes PAC 3100, 3200 and 4200

Enclosed Meters

Standard PAC Meter

Catalogue Number

E N C L X X X X X X X X X X X

Meter

- 31 PAC3120 Series Meter ①
- 32 PAC3220 Series Meter ②
- 42 PAC4200 Series Meter ②

Voltage

- 240 240 Volts
- 480 480 Volts
- 600 600 Volts

Wiring Configuration

- A 3 phase 3 wire
- B 3 phase 4 wire

Enclosure Type

- 01 Type 1
- 04 Type 4
- 12 Type 12

Communication

- TC Standard
- RT RTU ③
- PD Profibus ③
- PN Profinet ③
- BC BACNET

Options

- X 4DI + 2DO ④

① PAC3100 standard is Modbus RTU
 ② Only available for PAC3200 and 4200 Meter

③ PAC3200 and 4200 standard is Modbus TCP/IP
 ④ Only available for PAC4200 Meter

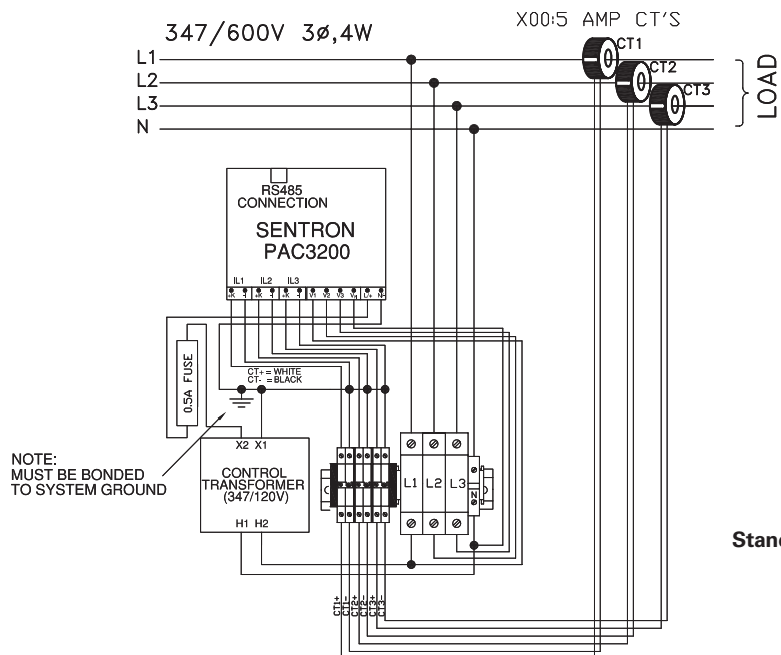

Standard PAC Meter in Enclosure Schematic

Enclosed Meters

Standard 9410 Meter

Catalogue Number

Catalogue No.

E N C L X X X X X X X X

Meter

94 9419RC - 9410 meter with remote display

Voltage

240 240 Volts
480 480 Volts
600 600 Volts

Wiring Configuration

A 3 phase 3 wire
B 3 phase 4 wire

Enclosure Type

01 Type 1
04 Type 4
12 Type 12

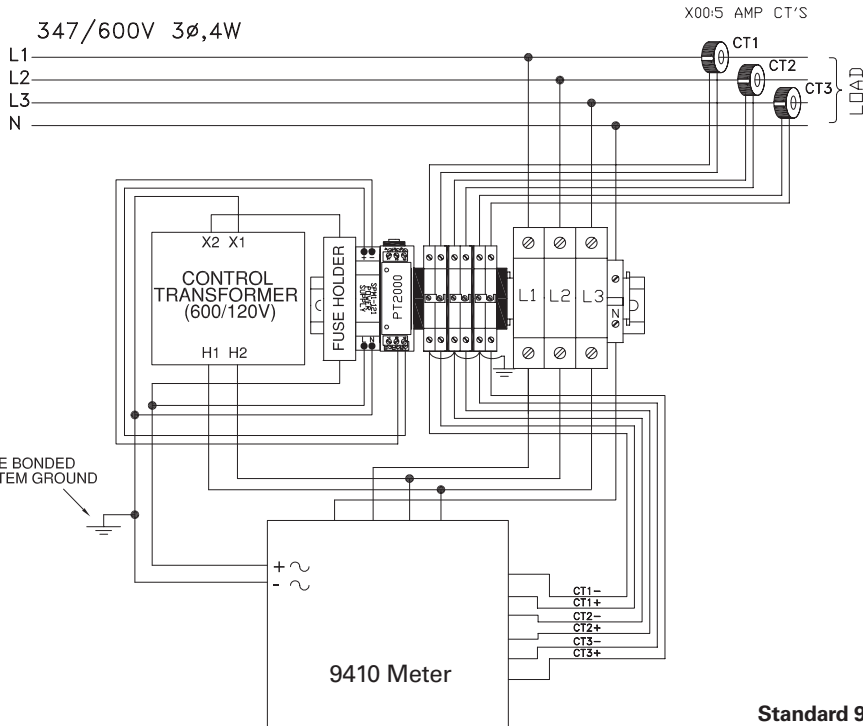

Standard 9410 Meter in Enclosure Schematic

Enclosed Meters

Multiple PAC Series Metering Solutions

With safety being paramount, Siemens has designed the SMU with many safety and convenience features in mind. These include a single circuit breaker for both the control voltage & voltage taps to protect internal wiring and the power meters from damage and allowing a "single source" disconnect from outside power, separate CT shorting blocks for each meter, a grounding lug and either the Modbus serial communications or TCP/IP will be terminated to one location for ease of network installation.

If required, a CPT will be provided for control voltages above 240 volts. This complete SMU solution is delivered ready to install with all the components pre-installed prior to shipment.

The Siemens PAC Series Metering Units (SMU) come completely pre-wired and ready to go with our standard PAC3100 and PAC3200 energy meter. The SMU also has the option of adding the PAC4200 meter as gateway. The SMU's can also be supplied with the more advanced Power Meters if required.

Multiple PAC Series Metering Solutions

- Replace multiple meters with one enclosure and save wall space.
- Improve energy efficiency.
- Aggregate Energy Purchases for reduced rates.
- Improve productivity, eliminate manual meter when coupled with Siemens WinPM.Net or other software through automatic reporting software

Typical SMU Network

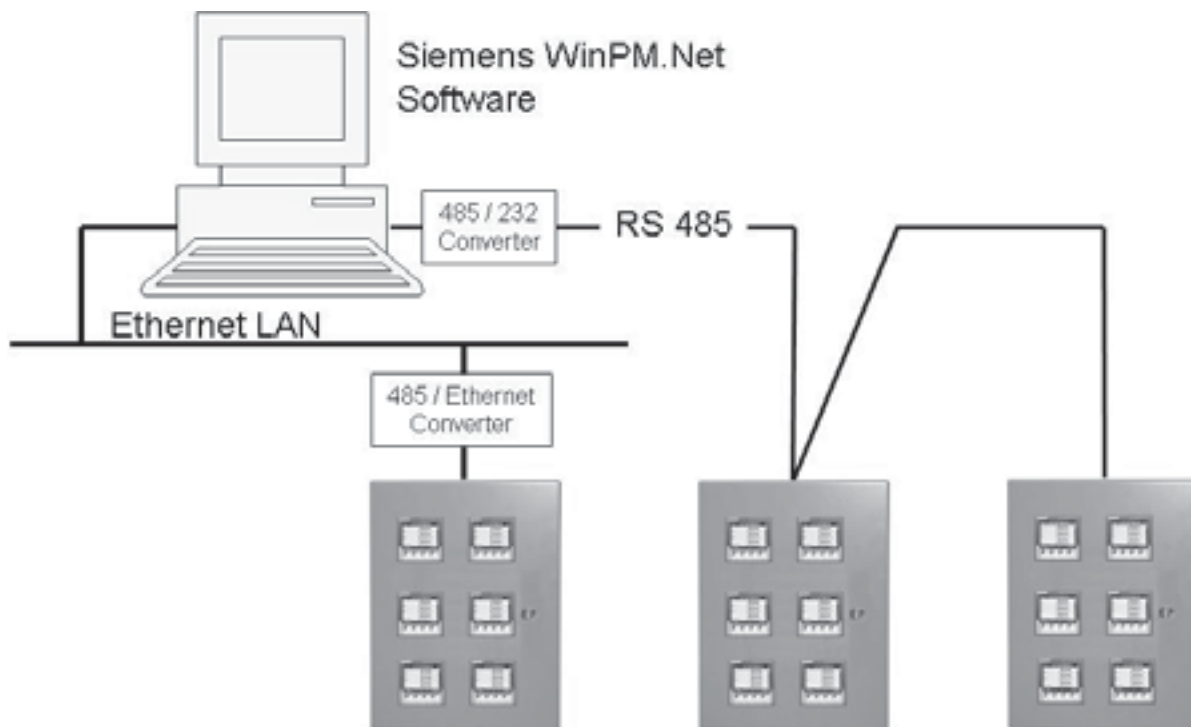

Enclosed Meters

Multiplier Meter in Enclosure

Catalogue Number

E N C L X X X X X X X X X X X

Meter

- 31 PAC3120 Series Meter ①
- 32 PAC3220 Series Meter ②
- 42 PAC4200 Series Meter ②

Voltage

- 240 240 Volts
- 480 480 Volts
- 600 600 Volts

Wiring Configuration

- A 3 phase 3 wire
- B 3 phase 4 wire

Panel Size

- 02 Two Meter Panel
- 03 Three Meter Panel
- 04 Four Meter Panel

Installed Meters

- 02 Two Meters Installed
- 03 Three Meters Installed
- 04 Four Meters Installed

Enclosure Type & Module

- X Type 1
- B Type 12
- C Type 4
- D Type 1 Modbus RTU ③
- F Type 12 Modbus RTU ③
- G Type 4 Modbus RTU ③
- H Type 1 Ethernet ④
- J Type 12 Ethernet ④
- K Type 4 Ethernet ④

Communication

- TC Standard
- RT RTU ③
- PD Profibus ③
- BC BACNET

① PAC3100 standard is Modbus RTU
 ② PAC3200 and 4200 standard is Modbus TCP/IP
 ③ All Meters will come with Modbus RTU communication.
 ④ All meter will come with TCP/IP protocol.
 PAC3100 meter will have Ethernet converter installed.

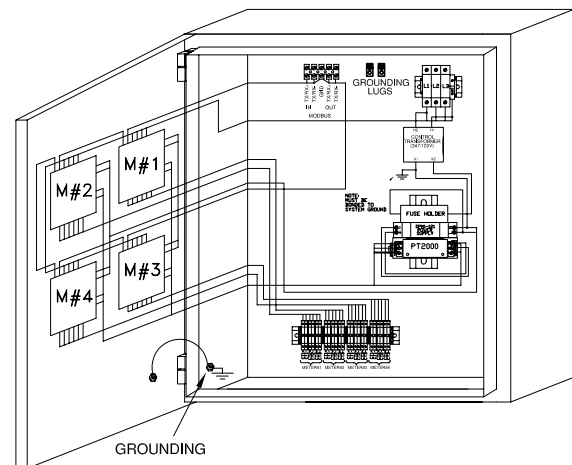

Branch Circuit Monitoring/ SEM3 Embedded Micro Sub Metering

Space Savings, Convenience, and Reliability with Siemens Branch Circuit Monitoring



In a world where tenant square footage is a premium in commercial building designs, the area for electrical metering is being drastically reduced, and critical power is being relied upon in data center applications, Siemens Branch Circuit Monitoring provides the solution.

The Siemens Branch Circuit Monitoring Solution utilizes the metering and monitoring technology integrated into the space saving panelboards from Siemens. When compared to the typical external wall mounted metering installations, considerable savings in space, installation costs, and data collection are realized with the Siemens Branch Circuit Monitoring Solution.

In addition, contractor labour costs for installation of sub-metering systems continues to increase. Still, building owners and property management companies must face the challenges of how to cost effectively provide tenant sub-metering in the constrained spaces.

To meet the sub-metering challenges of designers, contractors and property management companies, Siemens offers a proven cost-effective solution for Branch Circuit Monitoring/Embedded Metering. This solution combines a fully integrated metering system factory installed into the Siemens "P" series panelboards and switchboards, which along with the required local or remote sub-billing software, provides a "Total" sub-metering system.

Siemens Branch Circuit Monitoring / Embedded Metering Solution

- Saves you money – A tenant billing system improves cash flow, allows immediate pass-on of electric rate increases and helps building owners control costs. Tenants are confident they are paying their fair share for energy use and are saving money through energy conservation.
- Fast, low-cost installation – The embedded Siemens solution provides a faster and lower cost installation compared to other external systems.
- Lower space requirements – The embedded panelboard construction design requires no additional wall space to provide tenant metering. Conventional metering requires an external metering enclosure and possibly a current transformer transition cabinet.
- Reliable and accurate – Many Siemens systems are already in operation in large commercial and residential buildings around the country. Their accuracy exceeds utility industry and government standards like EPact 2005 for revenue grade meters.
- LEED certification – Provides the energy monitoring and logging required to achieve additional LEED points.
- Automated billing – With automated billing services the responsibility to acquire the data, store the data and bill the tenants is removed from the property management company, thus saving manpower and time.
- Responsive service – With remote monitoring, continuous 24/7 monitoring can be done by the property management company or tenants. The service can also relay consumption changes to the owners for immediate investigation.

Designer and contractor benefits include:

- Much smaller footprint versus the traditional socket meter combo units
- Factory pre-wired – less installation time
- Drastically less installation wiring
- No CT installation required in the field
- All equipment fits into the standard Siemens panel design
- Additional utilities like water, air and gas can be easily integrated into the system for a comprehensive monitoring system
- Hardwire and wireless communication options
- All components factory calibrated to meet revenue metering requirements
- Additional meters can be added in the field
- UL and CSA-us listed

Branch Circuit Monitoring applications include:

- Mixed Tenant & Retail
- Industrial Manufacturing
- Higher Ed
- Strip Malls
- Critical Power
- Government
- LEEDS buildings
- Airports

Please Contact Your Siemens Sales Engineer for additional information regarding Branch Circuit Monitoring / Embedded Metering

Branch Circuit Monitoring/ SEM3 Embedded Micro Sub Metering

Powerful embedded metering at the source of consumption!

The new Siemens Embedded Micro Metering Module (SEM3) is a modular metering solution for energy monitoring, data analysis, and sub billing applications. The flexible design allows for low, medium, and high density metering requirements to be met efficiently and economically using only a few standardized components integrated into Siemens Panelboard and Switchboard products. SEM3 is pre-engineered to integrate into new Siemens Panelboards and Switchboards but has also been designed to be implemented in OEM and retrofit applications as well.

The SEM3 provides an innovative and cost effective metering solution that can be incorporated into existing applications such as power monitoring, building automation, and sub-billing systems. SEM3 also has the flexibility to be installed as a standalone solution with real time data available from the controller's standard built-in web pages. This metering product has two levels of accuracy to meet the market's differing requirements and price points. This versatile system allows you to meter just the loads you need without the excess hardware and space requirements of traditional or competing solutions.



Features & Benefits:

- System designed to meter up to 45 metering points
- Easy retrofit and plug-n-play expansion features
- High metering accuracy up to 0.2%; standard 1.0%
- Installed and configured in SIEMENS engineered Panel boards, Switchboards, and Bus Plugs at SIEMENS Plants. SIEMENS ONE SOLUTION!
- Built-in HTML web pages for easy configuration & real-time data monitoring for Voltage, Current, Power, Energy, Water, and, Gas
- Modbus RTU, Modbus TCP, SNMP, NTP, BACnet IP & MSTP protocols
- Utilizes milliamp CT's reducing hardware and increasing safety
- Solid core CT's for high accuracy and split core CT's for easy retrofit.
- Emailing, Alarming, Trending, Totalizing, Event Logging & Data Logging
- Offline Configuration for improving Field and Factory engineering time
- 4 Language support includes English, German, French, and Spanish

Order Information

Controller		Catalogue Number
Main Controller		SEM3CONTROLLER
Main Controller – External power supply input 120V/125VDC for powering up the controller. Leads are available for voltage measuring sources. Pulse output feature is not available in this variant.		SEM3CONT120V
Meter Modules		
Meter - Standard Accuracy 1% with Pulse Output		SEM3PLAMETER
Meter - High Accuracy 0.2% with Pulse Output		SEM3PHAMETER
Meter Modules		
Meter Rack 3 Position		SEM3RACK3
Meter Rack 6 Position		SEM3RACK6
Meter Rack 9 Position		SEM3RACK9
Meter Rack 15 Position		SEM3RACK15
Meter Rack 21 Position		SEM3RACK21
Cables		
Controller to Rack Cable - 6 Inch		SEM3CAB6INCH
Controller to Rack Cable - 12 Inch		SEM3CAB12INCH
Controller to Rack Cable - 24 Inch		SEM3CAB24INCH
Controller to Rack Cable - 36 Inch		SEM3CAB36INCH
Controller to Rack Cable - 5 Foot		SEM3CAB5FT
Controller to Rack Cable - 10 Foot		SEM3CAB10FT
Controller to Rack Cable - 20 Foot		SEM3CAB20FT
Solid Core CT's		
Solid Core CT 50:0.1		SEM3SCCT50
Solid Core CT 125:0.1		SEM3SCCT125
Solid Core CT 250:0.1		SEM3SCCT250
Solid Core CT 400:0.1		SEM3SCCT400
Solid Core CT 600:0.1		SEM3SCCT600
Solid Core CT 800:0.1		SEM3SCCT800
Solid Core CT 1200:0.1		SEM3SCCT1200
Solid Core CT 1600:0.1		SEM3SCCT1600
Solid Core CT 2000:0.1		SEM3SCCT2000
Split Core CT's		
Split Core CT 50:0.1		7KT1280-5MA00
Split Core CT 125:0.1		7KT1280-5MA01
Split Core CT 250:0.1		7KT1280-5MA02
Split Core CT 400:0.1		7KT1280-5MA03
Split Core CT 600:0.1		7KT1280-5MA04
Split Core CT 800:0.1		7KT1280-5MA05
Split Core CT 1200:0.1		7KT1280-5MA06
Split Core CT 1600:0.1		7KT1280-5MA07
Split Core CT 2000:0.1		7KT1280-5MA08

Embedded Micro Metering Module™

Selection

Meter Rack
(3, 9, 15, 21)

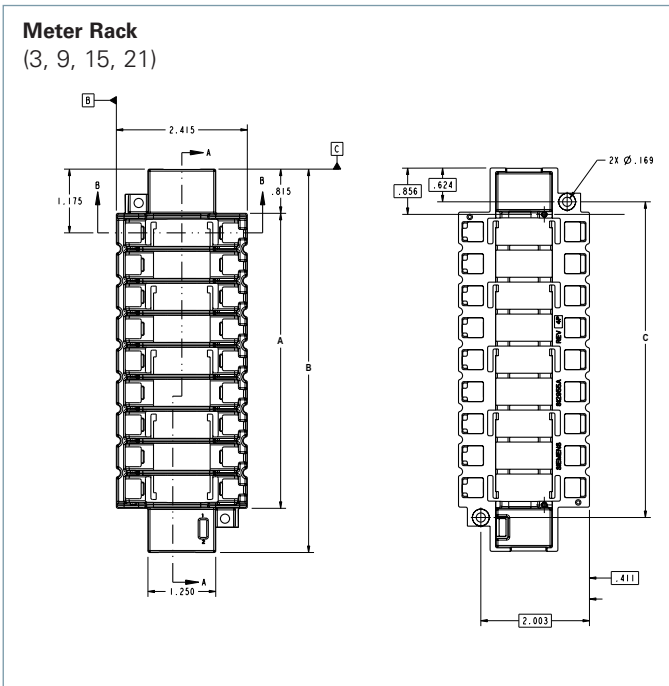

Meter Rack
(3, 9, 15, 21)

Catalogue Number	Description	Variable Dimensions (inches)		
		A	B	C
SEM3RACK3	3 position rack	1.900	3.570	2.282
SEM3RACK6	6 position rack	3.670	5.340	4.050
SEM3RACK9	9 position rack	5.440	7.070	5.822
SEM3RACK15	15 position rack	8.980	10.610	9.362
SEM3RACK21	21 position rack	12.520	14.150	12.902

Controller Dimensions

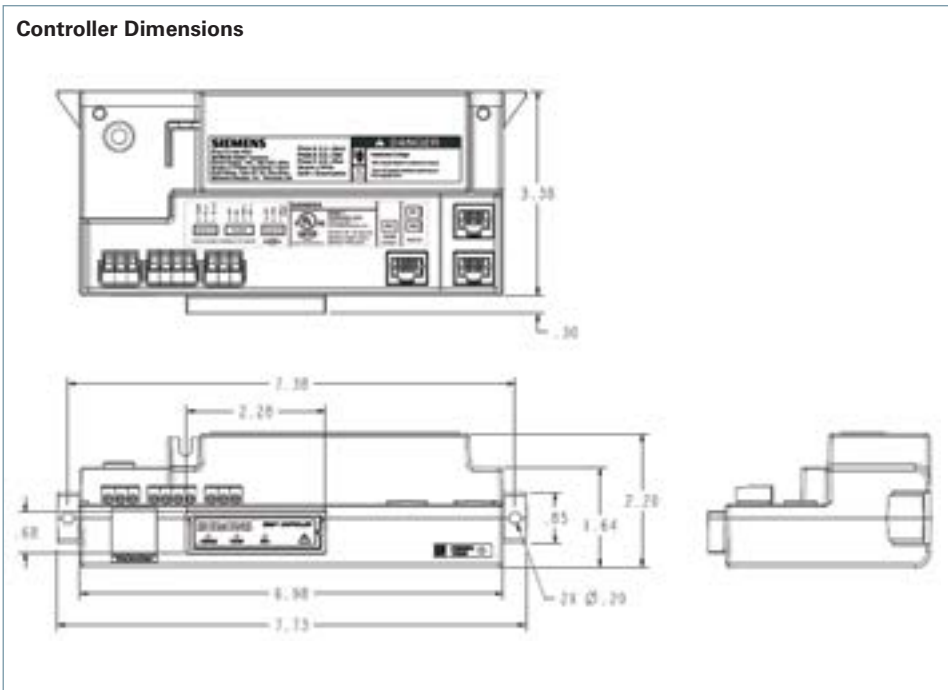

Controller

Catalogue no.
SEM3CONTROLLER

Embedded Micro Metering Module™

Selection

Current Transformer – Solid Core

Description	Catalogue Number	Dimensions (Inches)						
		A	B	C	D	E	F	G
Solid Core CT 50:0.1	SEM3SCCT50	1.40	0.38	0.20	0.92	2.12	0.74	0.37
Solid Core CT 125:0.1	SEM3SCCT125	1.40	0.66	0.20	0.92	2.16	0.74	0.37
Solid Core CT 250:0.1	SEM3SCCT250	1.90	0.93	0.20	0.92	2.75	0.78	0.39
Solid Core CT 400:0.1	SEM3SCCT400	2.62	1.60	0.20	0.92	3.62	0.78	0.39
Solid Core CT 600:0.1	SEM3SCCT600	3.74	2.30	0.24	0.92	4.66	0.78	0.39
Solid Core CT 800:0.1	SEM3SCCT800	4.05	2.60	0.24	0.92	5.05	0.98	0.49
Solid Core CT 1200:0.1	SEM3SCCT1200	4.56	2.80	0.24	0.92	5.57	0.98	0.49
Solid Core CT 1600:0.1	SEM3SCCT1600	6.00	4.25	0.28	1.07	7.15	1.05	0.50
Solid Core CT 2000:0.1	SEM3SCCT2000	6.00	4.25	0.28	1.07	7.15	1.05	0.50

Current Transformer – Solid Core

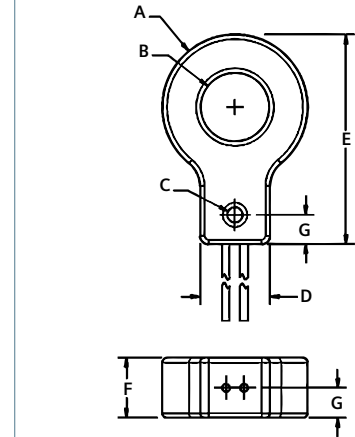

Current Transformer – Split Core

Description	Catalogue Number	A	B	C	D	E	F
Split Core CT 50:0.1	7KT1280-5MA00	0.50	0.50	2.40	2.69	0.95	1.10
Split Core CT 125:0.1	7KT1280-5MA01	0.75	0.75	2.40	2.69	0.83	0.94
Split Core CT 250:0.1	7KT1280-5MA02	1.00	1.00	2.87	3.24	0.94	1.11
Split Core CT 400:0.1	7KT1280-5MA03	1.50	1.50	3.60	3.75	1.05	1.15
Split Core CT 600:0.1	7KT1280-5MA04	2.14	2.17	4.72	4.32	1.28	1.15
Split Core CT 800:0.1	7KT1280-5MA05	3.00	3.14	5.56	5.27	1.21	1.16
Split Core CT 1200:0.1	7KT1280-5MA06	3.27	3.02	6.48	5.69	1.73	1.48
Split Core CT 1600:0.1	7KT1280-5MA07	4.50	4.50	7.68	7.14	1.59	1.48
Split Core CT 2000:0.1	7KT1280-5MA08	4.50	4.50	7.68	7.14	1.59	1.48

Current Transformer – Split Core

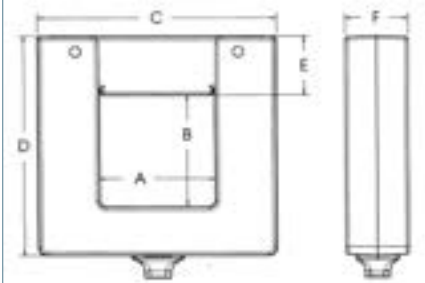

Meter Module

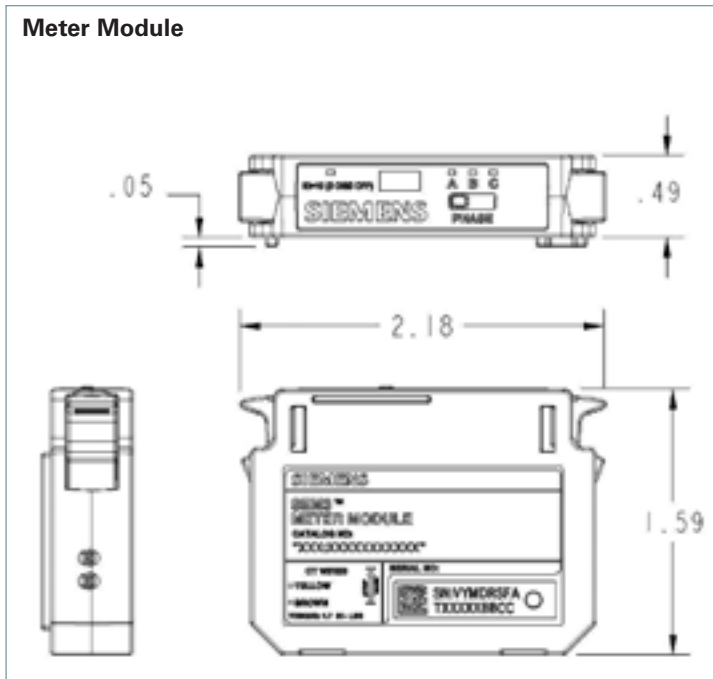

Meter Module

Description	Catalogue No.
Meter - Standard Accuracy 1% with Pulse Output	US2:SEM3PLAMETER
Meter - High Accuracy 0.2% with Pulse Output	US2:SEM3PHAMETER

Enclosures for External Applications

Standard Enclosures for External Applications

Typical SEM3™ with display example



The SEM3 standalone enclosure is ideal for retrofit/external wall mount applications, as it requires minimal modification of existing systems while gaining full functionality of the SEM3 branch circuit monitoring solution. Installation of the required milliamp current transformers (CT) is minimized by utilizing the Siemens Split Core CTs ranging from 50 to 2000 Amps. See “Split Core CT” section.

SEM3 standard enclosures are available with NEMA 1, 4 and 12 ratings. The

SEM3 meter enclosure is shipped with all the required components installed. The control voltage is wired to a fusible disconnect switch to protect the system and to provide a disconnect from outside power to the meter. SEM3 Solid Core CTs are self shorting, not requiring a shorting block in the enclosure/panel. Shorting blocks are recommended for SEM3 Split Core CT’s installed in an enclosure/panel. The enclosure has a ground lug for equipment grounding. When the control voltage is greater than

480 volts, a CPT is provided between the disconnect switch and SEM3 controller. The enclosure is pre-drilled to make mounting quick and easy.

The standard enclosure comes with the controller, power supply, disconnect, meter racks, communication cables, and shorting blocks. Meter modules and CTs are added separately. As mentioned previously, the display is available as an option.

No Display Standard Enclosure for External Application – HMI, SEM3 Meter Modules, and CT’s are not included	
Description	Catalogue Numbers
SEM3 3M ENCL Type 1 16T x 12W X 6D	SEM303ENCL1
SEM3 3M ENCL Type 12 16T x 12W X 6D	SEM303ENCL12
SEM3 3M ENCL Type 4 16T x 12W X 6D	SEM303ENCL4
SEM3 9M ENCL Type 1 16DT x 12W X 6D	SEM309ENCL1
SEM3 9M ENCL Type 12 16DT x 12W X 6D	SEM309ENCL12
SEM3 9M ENCL Type 4 16DT x 12W X 6D	SEM309ENCL4
SEM3 15M ENCL Type 1 16DT x 12W X 6D	SEM315ENCL1
SEM3 15M ENCL Type 12 16DT x 12W X 6D	SEM315ENCL12
SEM3 15M ENCL Type 4 16DT x 12W X 6D	SEM315ENCL4
SEM3 18M ENCL Type 1 20T x 12W x 6D	SEM318ENCL1
SEM3 18M ENCL Type 12 20T x 12W x 6D	SEM318ENCL12
SEM3 18M ENCL Type 4 20T x 12W x 6D	SEM318ENCL4
SEM3 21M ENCL Type 1 20T x 12W x 6D	SEM321ENCL1
SEM3 21M ENCL Type 12 20T x 12W x 6D	SEM321ENCL12
SEM3 21M ENCL Type 4 20T x 12W x 6D	SEM321ENCL4
SEM3 30M ENCL Type 1 20T x 16W x 6.62D	SEM330ENCL1
SEM3 30M ENCL Type 12 20T x 16W x 6.62D	SEM330ENCL12
SEM3 30M ENCL Type 4 20T x 16W x 6.62D	SEM330ENCL4
SEM3 42M ENCL Type 1 20T x 16W x 6.62D	SEM342ENCL1
SEM3 42M ENCL Type 12 20T x 16W x 6.62D	SEM342ENCL12
SEM3 42M ENCL Type 4 20T x 16W x 6.62D	SEM342ENCL4
SEM3 45M ENCL Type 1 20T x 16W x 6.62D	SEM345ENCL1
SEM3 45M ENCL Type 12 20T x 16W x 6.62D	SEM345ENCL12
SEM3 45M ENCL Type 4 20T x 16W x 6.62D	SEM345ENCL4



SEM3 Enclosure without display



SEM3 Enclosure without meter modules installed

Enclosures for External Applications

Selection

Standard Enclosure with HMI Display & Switch for External Application – SEM3 Meter Modules, and CT's are not included

Description	Catalogue Numbers
SEM3 3M w/display/switch 16 x 16 x 6.5	SEM303ENCL1DS
SEM3 3M w/display 16 x 16 x 6.5	SEM303ENCL1D
SEM3 9M w/display/switch 16 x 16 x 6.5	SEM309ENCL1DS
SEM3 9M w/display 16 x 16 x 6.5	SEM309ENCL1D
SEM3 15M w/display/switch 20 x 16 x 8	SEM315ENCL1DS
SEM3 15M w/display 20 x 16 x 8	SEM315ENCL1D
SEM3 18M w/display/switch 20 x 16 x 8	SEM318ENCL1DS
SEM3 18M w/display 20 x 16 x 8	SEM318ENCL1D
SEM3 21M w/display/switch 20 x 16 x 8	SEM321ENCL1DS
SEM3 21M w/display 20 x 16 x 8	SEM321ENCL1D
SEM3 30M w/display/switch 20 x 20 x 8	SEM330ENCL1DS
SEM3 30M w/display 20 x 20 x 8	SEM330ENCL1D
SEM3 42M w/display/switch 20 x 20 x 8	SEM342ENCL1DS
SEM3 42M w/display 20 x 20 x 8	SEM342ENCL1D
SEM3 45M w/display/switch 20 x 20 x 8	SEM345ENCL1DS
SEM3 45M w/display 20 x 20 x 8	SEM345ENCL1D



Remote Touch Display Enclosure Package - No SEM3 parts included

Description	Catalogue Numbers
SEM3 ENCL 7" Touch Display 24 VDC/1.3 Amp Power Supply	SEM3TP7SEN
SEM3 ENCL 7" Touch Display 24 VDC/1.3 Amp PS UL Listed	SEM3TP7SENUL
SEM3 ENCL 7" Touch Display 24 VDC/1.3 Amp PS + 8 Port Switch	SEM3TP7AEN
SEM3 ENCL 7" Touch Display 24 VDC/1.3 Amp PS + 8 Port Switch UL Listed	SEM3TP7AENUL
SEM3 ENCL 9" Touch Display 24 VDC/1.3 Amp Power Supply	SEM3TP9SEN
SEM3 ENCL 9" Touch Display 24 VDC/1.3 Amp PS UL Listed	SEM3TP9SENUL
SEM3 ENCL 9" Touch Display 24 VDC/1.3 Amp PS + 8 Port Switch	SEM3TP9AEN
SEM3 ENCL 9" Touch Display 24 VDC/1.3 Amp PS + 8 Port Switch UL Listed	SEM3TP9AENUL
SEM3 ENCL 12" Touch Display 24 VDC/1.3 Amp Power Supply	SEM3TP12SEN
SEM3 ENCL 12" Touch Display 24 VDC/1.3 Amp PS UL Listed	SEM3TP12SENUL
SEM3 ENCL 12" Touch Display 24 VDC/1.3 Amp PS + 8 Port Switch	SEM3TP12AEN
SEM3 ENCL 12" Touch Display 24 VDC/1.3 Amp PS + 8 Port Switch UL Listed	SEM3TP12AENUL



Optional Loose Remote Touch Display and Power Supply

Description	Catalogue Numbers
SEM3 7" TD 100-240VAC + SITOP PS 24VDC	SEM3TOUCHP7
SEM3 9" TD 100-240VAC + SITOP PS 24VDC	SEM3TOUCHP9
SEM3 12" TD 100-240VAC + SITOP PS 24VDC	SEM3TOUCHP12
SEM3 15" TD 100-240VAC + SITOP PS 24VDC	SEM3TOUCHP15
SEM3 19" TD 100-240VAC + SITOP PS 24VDC	SEM3TOUCHP19



MD Series Power Meter

MD Standalone and High Density Power Meters

Siemens Industry's MD Model Power Meters are sub metering devices designed to provide real time, accurate electricity metering to enable proper control over energy costs. The meter can capture kWh/kW energy and demand data, as well as virtually all relevant energy parameters for diagnostics and monitoring on three-phase or single-phase circuit installations. The meters' flexibility, size, and ease-of-use make them ideal tools for gathering detailed consumption information in commercial, industrial, governmental, and retail environments. The meters use direct connections to each phase of the voltage and various interchangeable current transformer (CT) options such as split-core CTs or flexible Rogowski Coils (for large loads or large cables and buss bars) to monitor current on each phase. All of Siemens' current transformers are internally shunted for intrinsically safe operation on energized conductors.

The power meters make over 75 total electrical measurements which are derived from the voltage and current inputs. Electrical load diagnostic parameters such as power factor and line frequency are captured in addition to energy and demand values. The Siemens MD Power Meters require no external power and the power supplies can accommodate service voltages ranging from 80 to 600V (phase-to-phase). The simple installation is accomplished by connecting the color-coded voltage leads and clearly labeled CTs. A three-LED indicator display confirms proper CT-to-phase installation. The meters automatically adjust for CT orientation—greatly reducing set-up time and all but eliminating installation errors.



MD Meter Series Base Model	Catalogue Number
MD Meter BACnet-Modbus DIN Rail Mount with Display	MD3HDRDN
MD Meter BACnet-Modbus Wall Mount Cabinet/Enclosure with Display	MD3HDCDN
MD Meter BACnet-Modbus 12 Circuit Cabinet/Enclosure with Display	MD12HDCDN
MD Meter BACnet-Modbus 24 Circuit Cabinet/Enclosure with Display	MD24HDCDN
MD Meter BACnet-Modbus 48 Circuit Cabinet/Enclosure with Display	MD48HDCDN
0.333mV Output Current Transformers	Catalogue Number
Mini SplitCore 0.4 Opening 100A	SCTHMC0100U
Mini SplitCore 0.4 Opening 200A	SCTHMC0200U
Small SplitCore 0.75 Opening 50A	SCTSCS0050U
Small SplitCore 0.75 Opening 100A	SCTSCS0100U
Medium SplitCore 1.25 Opening 100A	SCTSCM0100U
Medium SplitCore 1.25 Opening 200A	SCTSCM0200U
Medium SplitCore 1.25 Opening 400A	SCTSCM0400U
Medium SplitCore 1.25 Opening 600A	SCTSCM0600U
Large SplitCore 2.00 Opening 600A	SCTSCL0600U
Large SplitCore 2.00 Opening 1000A	SCTSCL1000U
0.333mV Output Rogowski Coil Current Transformers	Catalogue Number
Rogowski Coil Current Transformer, 16" (40 cm); 4.5" (11.5 cm) opening; 4000A	SCTR161310U
Rogowski Coil Current Transformer, 24" (60 cm); 7.0" (18 cm) opening; 4000A	SCTR241310U
Rogowski Coil Current Transformer, 36" (90 cm); 10.8 (28 cm) opening; 4000A	SCTR361310U

Low Voltage Current Transformers

Comprehensive metering grade CT offering split-core, flexible and solid core designs

Split core – Rectangular Window

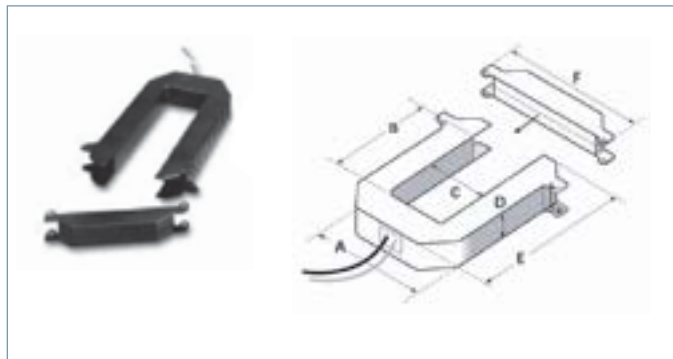

200A – 300A	400A – 800A	1000A – 1200A
A = 3.75" (95mm)	A = 4.90" (124mm)	A = 4.90" (124mm)
B = 1.51" (38mm)	B = 2.89" (73mm)	B = 5.50" (140mm)
C = 1.25" (32mm)	C = 2.45" (62mm)	C = 2.45" (62mm)
D = 1.13" (29mm)	D = 1.13" (29mm)	D = 1.13" (29mm)
E = 4.20" (107mm)	E = 5.57" (141mm)	E = 8.13" (207mm)
F = 4.75" (121mm)	F = 5.91" (150mm)	F = 5.92" (150mm)

Siemens Instrument Grade Current Transformers (CT) have a split-core construction and provide a safe 5A secondary output. These split-core current transformers allow for easy installation, retrofit, and service. CT's come with 4' leads (18 gauge). Use on low voltage applications of 600V or less.

Accuracy 0.5%.

Amps	Window (C x B)	Catalogue Number
100A	1.25"x1.15"	PDS-CTSC-011
200A	1.25"x1.51"	PDS-CTSC-021
300A	1.25"x1.51"	PDS-CTSC-031
400A	2.45"x2.89"	PDC-CTSC-042
600A	2.45"x2.89"	PDS-CTSC-062
800A	2.45"x2.89"	PDS-CTSC-083
1000A	2.45"x5.50"	PDS-CTSC-013
1200A	2.45"x5.50"	PDS-CTSC-123
1600A	2.45"x5.50"	PDS-CTSC-163
2000A	2.45"x5.50"	PDS-CTSC-200
3000A	2.75"x6.625"	PDS-CTSC-03R

Split-core – Round Window

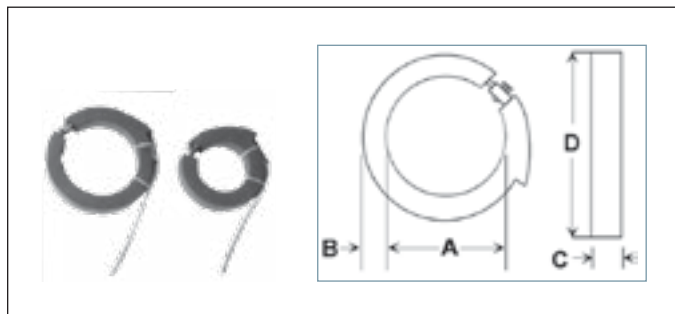

200A – 1200A	3000A – 4000A
A = 4.00"	A = 6.00"
B = 1.25"	B = 1.25"
C = 1.50"	C = 1.50"
D = 6.50"	D = 8.50"

Split-core round rubber insulated flexible CT's with 12' heavy duty leads (18 AWG) and 5A secondary output for use on low voltage applications of 600V.

Accuracy is 4% for 200/400A, 3% for 400A, and 2% for 600A and above.

Amps	Window (A)	Catalogue Number
200A	4.00"	PDS-CTHC-024
300A	4.00"	PDS-CTHC-034
400A	4.00"	PDC-CTHC-044
600A	4.00"	PDS-CTHC-064
800A	4.00"	PDS-CTHC-084
1200A	4.00"	PDS-CTSC-123
2000A	6.00"	PDS-CTHC-206
3000A	6.00"	PDS-CTHC-306
4000A	6.00"	PDS-CTHC-406

Low Voltage Current Transformers

Comprehensive metering grade CT offering split-core, flexible and solid core designs

Solid-core – Round with Round Window

The small size solid core Current Transformer (CT) are designed for tight locations and new installations providing a safe 5 amp secondary for use on voltage applications of 600V or less.

Accuracy is 0.3%.

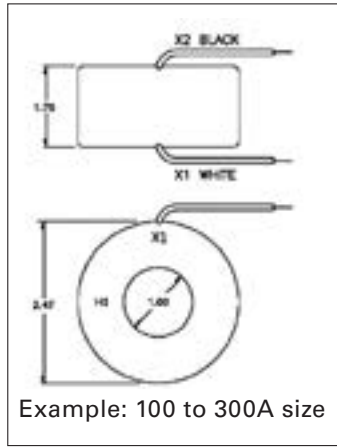

Example: 100 to 300A size

Solid core – Round metering grade, 600V		
Catalogue Number	Primary	Size
SMU-CT-011	100A	1.75" x 2.47"; 1" Window
SMU-CT-021	200A	1.75" x 2.47"; 1" Window
SMU-CT-025	250A	1.75" x 2.47"; 1" Window
SMU-CT-031	300A	1.75" x 2.47"; 1" Window
SMU-CT-041	400A	1.1" x 3.56"; 1.56" Window
SMU-CT-061	600A	1.1" x 3.56"; 1.56" Window
SMU-CT-081	800A	1.1" x 3.56"; 1.56" Window
SMU-CT-123	1000A	1.1" x 3.56"; 1.56" Window
SMU-CT-02R	2000A	1.15" x 5.73"; 3.25" Window

Solid-core – Square with Round Window

Siemens Instrument Grade Current Transformers (CT) are designed as solid-core construction and provide a safe 5A secondary output. Solid-core CT's come with terminals for attaching leads. Use on low voltage applications of 600V or less.

Accuracy is 0.3%.

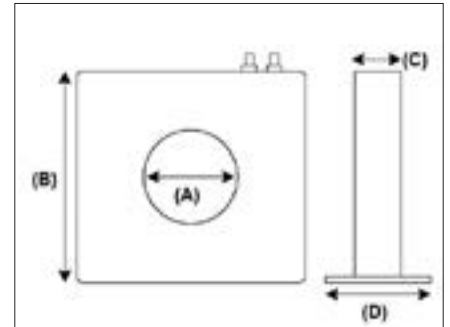

Amps	Dimension (A x B x C x D)	Catalogue Number
200:5	1.25" x 4.88" x 2.19" x 4.68"	PDS-CTRC-021
300:5	1.25" x 4.88" x 2.19" x 4.68"	PDS-CTSC-031
400:5	1.25" x 4.88" x 2.19" x 4.68"	PDS-CTRC-041
500:5	1.25" x 5.10" x 3.00" x 5.50"	PDC-CTRC-051
600:5	1.25" x 5.10" x 3.00" x 5.50"	PDS-CTRC-061
800:5	1.25" x 5.10" x 3.00" x 5.50"	PDS-CTRC-081
1000:5	1.25" x 5.10" x 3.00" x 5.50"	PDS-CTRC-101
100:5	2.25" x 6.31" x 3.00" x 5.82"	PDS-CTRC-012
200:5	2.25" x 6.31" x 3.00" x 5.82"	PDS-CTRC-022
300:5	2.25" x 6.31" x 3.00" x 5.82"	PDS-CTRC-032
400:5	2.25" x 6.31" x 3.00" x 5.82"	PDS-CTRC-042
800:5	4.00" x 6.44" x 3.25" x 3.25"	PDS-CTRC-084
1000:5	4.00" x 6.44" x 3.25" x 3.25"	PDS-CTRC-104
1200:5	4.00" x 6.44" x 3.25" x 3.25"	PDS-CTRC-124
1600:5	4.00" x 6.44" x 3.25" x 3.25"	PDS-CTRC-164
2000:5	4.00" x 6.44" x 3.25" x 3.25"	PDS-CTRC-204
3200:5	6.50" x 9.88" x 7.00" x 7.00"	PDS-CTRC-326
4000:5	6.50" x 9.88" x 7.00" x 7.00"	PDS-CTRC-426

Shorting Block

All low voltage current transformers should be installed with a shorting block to allow for easy removal of the metering unit and to provide a safe method for disconnecting the CT signal. One shorting block is required per meter. Various size shorting blocks are available; 4, 6, and 8 pole configurations are available with four slotted shorting screws and cover. Wire size is 18-10 AWG.

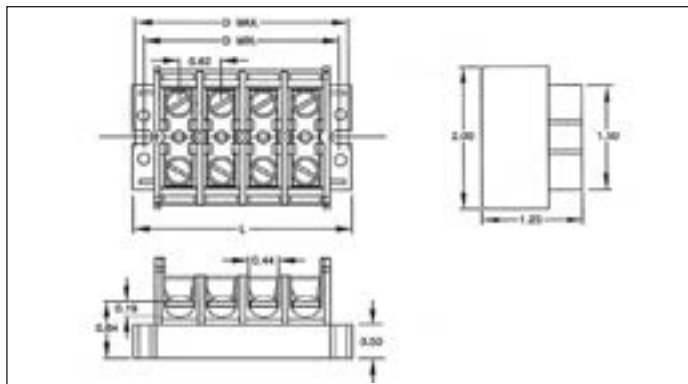

Catalogue Number	Ckts.	Mounting		
		L	D min.	D max.
IKU4SC	4	3.25	2.88	3.00
IKU6SC	6	4.50	4.12	4.25
IKU8SC	8	5.75	5.38	5.50
IKU12SC	12	8.25	7.88	8.00

Typical electrical meter CT and shorting block installation

This example shows a common three phase, three wire installation where three CT's and one shorting block are used.

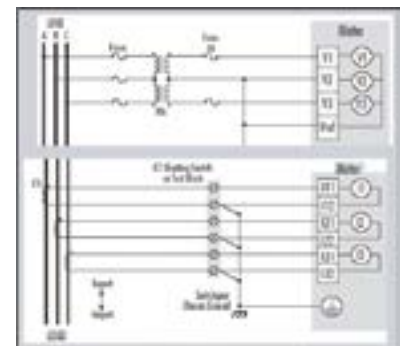

Avoid downtime with 24/7 continuous monitoring via SIEMENS SEM3T Thermal Monitoring



For many years, scheduled infrared thermography (IR) inspections have been the accepted method for reducing risk of fire by identifying faulty or loose connections in electrical distribution systems. SEM3T is a system specifically designed to provide continuous thermal monitoring. It offers a safer, more effective way to detect thermal risks before they progress into a major failure.

The method also delivers up to a 10:1 return on investment due to avoided equipment damage and downtime.

Continuous Thermal Monitoring is now enabling safer, more efficient inspection of energized electrical equipment,

ensuring electrical asset integrity. This becomes apparent when looking at the technology comparison of SEM3T to IR windows and thermal imaging.

To meet the thermal monitoring challenges of operations owner, design engineers, and contractors, Siemens offers a proven cost-effective solution for Thermal Monitoring. This solution combines a fully integrated thermal monitoring system factory installed into the Siemens Panelboards, Switchboards, and Switchgears, which along with the required local or remote monitoring software, provides a “Total” Power and Thermal monitoring system.

Siemens Thermal Monitoring/ Embedded Monitoring Solution

- **Saves you money** – SIEMENS SEM3T thermal monitoring system specifically designed to provide 24x7 detection of hotspots at an early stage of development; thus, avoiding potential downtime resulting from Arc Flash / power outage incidents.
- **Fast, low-cost installation** – The embedded Siemens solution provides a faster and lower cost installation compared to other external systems.
- **Safety in mind** – SIEMENS thermal monitoring system is safer, more effective way to detect thermal risks before they progress into a major failure.
- **Minimum space requirements** – The embedded switchgear, switchboard and panelboard construction design requires no additional wall space to provide thermal monitoring.
- **Reliable and accurate** – SIEMENS thermal monitoring system is non-invasive reliable and easily installed thermal monitoring solution which can monitor numerous locations within low voltage apparatus including bus joints, lug landings, bus ducts, transformers, and circuit breakers. Thermal sensors can be positioned appropriately to detect ambient temperature, as well as overloaded or poorly conducting electrical connections.
- **Automated alert notifications** – With automated alert notification services the responsibility to acquire the data, store the data and analyze the data is removed from the facility management company, thus saving manpower and time.
- **Responsive service** – With remote monitoring, continuous 24/7 monitoring can be done by the facility management company or local users. The service can also relay thermal hotspot conditions changes to the owners for immediate investigation.

Designer and Contractor benefits include:

- No need to wait for inspector to scan the system to understand abnormalities
- Factory pre-wired – less installation time
- Drastically less installation wiring & cost
- Thermal sensors are calibrated to meet the accuracy standards and requirements
- All equipment fits into the standard Siemens electrical equipment design
- cUL, CE (Pending) approved
- Embedded web-server for on-site configuration, real time data display, data logging, event logging, trending and alarm notifications.
- Built-in industry standard Modbus TCP communication
- Dual Ethernet ports for daisy chaining over Ethernet and Wi-Fi as an option
- Monitor 1 to 45 thermal points.
- Web pages can also be set by a user to four different languages (English, German, French, or Spanish) for configurations and real-time data display

Thermal Monitoring applications include:

- Industrial Manufacturing
- Critical Power - Data Centers and Hospitals
- Government
- LEEDS buildings
- Airports
- Higher Education

Please Contact Your Siemens Sales Engineer for additional information regarding Thermal Sensing:

SEM3T System Overview

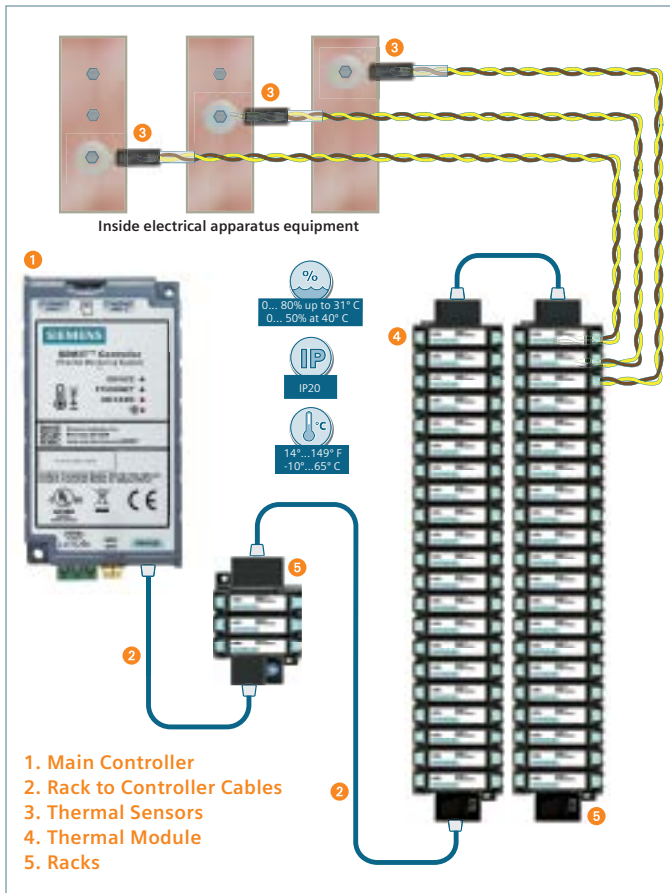

SEM3T Controller

SEM3T Controller can provide thermal monitoring for up to 45 Thermal points. SEM3T Controller acts as a Data Server and processes the data from the Thermal Modules. The controller can be configured to create several groups with multiple thermal points. This information either viewed in real-time or communicated to other systems through its communication interfaces. Some applications may require for more than 45 thermal points in one apparatus electrical equipment. If so, then simply add a second controller. Two controllers can monitor up to 90 thermal points. Using the available dual Ethernet ports in each controller, daisy chaining of multiple controllers in a serial fashion is achievable.

- SEM3T Controller has built-in web pages for real-time data, historical logging/trending, alarm notifications, KPI dash boards, and configurations
- Easy to integrate to Siemens MindSphere cloud platform – MindSphere ready device
- 24vdc power supply
- Optional Wi-Fi
- Available standard communication protocol: Modbus TCP for integration with monitoring software system, SMTP for emailing, and NTP for network time synchronization
- Dual Ethernet (RJ45) ports for daisy chain over Ethernet
- Meets global certifications/ standards

SEM3T Thermal Module

The Thermal Module reads the address from the racks designated by its location and thermal signals from its respective thermal sensor. Each Thermal Module is an independent thermal module that samples thermal signals, processes these signals using the embedded algorithms and communicates these parameters to the controller. When the thermal module is powered and is communicating properly with the controller, the power LED will blink.

- One thermal module per thermal monitoring location
- No configuration required for the modules
- Connects directly to thermal sensors

SEM3T Thermal Sensors

Thermal Sensors are components used for thermal measurement. SEM3T product is UL listed. Thermal Sensor lead wires come with standard 10' can be extended up to 50', still maintaining the thermal output accuracy.

- Thermal Sensors are designed to work specifically with the SEM3T product
- Lead wire type: UL rated operating temperature to 200°C, 600V rated, UL style 1199, 18AWG, 10 x 30 stranded
- Primary rating: 600VAC
- Overvoltage category: CAT IV
- Operating temperature 0°C to 130°C
- Very reliable non-powered wired Sensors are designed to withstand harsh environments Thermal Sensors come in the following variants and sizes:
 - 4 types Sensor Screw Ring terminals for monitoring thermal points at joint locations
 - Sensor S-Ring sizes: 1/4", 5/16", 3/8", 1/2"
 - Cylindrical sensor for monitoring ambient temperature
 - Sensor C-Ring

SEM3 Racks

The SEM3 Racks are the holders for the thermal modules. Embedded within a rack is the internal addressing for the communication of thermal information from the module to the controller via Ethernet cables. A two-way DIP switch is available on the 9, 15, and 21 position racks for thermal monitoring addressing, whereas a rotary switch is available to set the addressing on 3 and 6 position racks.

- Five types of racks available
- DIP switch or rotary switch for controller to recognize module location and rack assignments

Rack to Controller Cables

The communications cables connect the SEM3 racks to the controller and daisy chain additional meter racks together in series (for 3 and/or 6 meter module racks only). Multiple lengths are available to suit a wide variety of panelboard and switchboard configurations. The data cables are insulated for 600V applications and are not standard Ethernet cables. **NOTE:** See ordering information page for cable sizes and catalog numbers.

- Seven cable lengths
- 600V rated Ethernet cable. Note: Regular Ethernet RJ45 cables are rated only up to 300V and are not allowed to use for this application

SEM3T Controller

Ordering information

Part	Catalogue Number
SEM3T Controller with Wi-Fi	7KT1281-0AA10
SEM3T Controller without Wi-Fi	7KT1281-0AA00

Controller

Description	Information
Altitude / Elevation	3000 Meters/9843 Feet
Humidity	Maximum relative humidity 80% for temperature up to 31°C decreasing linearly to 50% relative humidity at 40°C
Operating Temperature Range	-10°C to +65°C / 14°F to 149°F
Power Supply Requirement	UL Listed 24V DC Class II power supply.



AWG

24 V DC power supply leads	5 [.56]	.50 to 2.50	22 to 14
Thermal Sensor Leads	1.7 [.19]	0.75	18

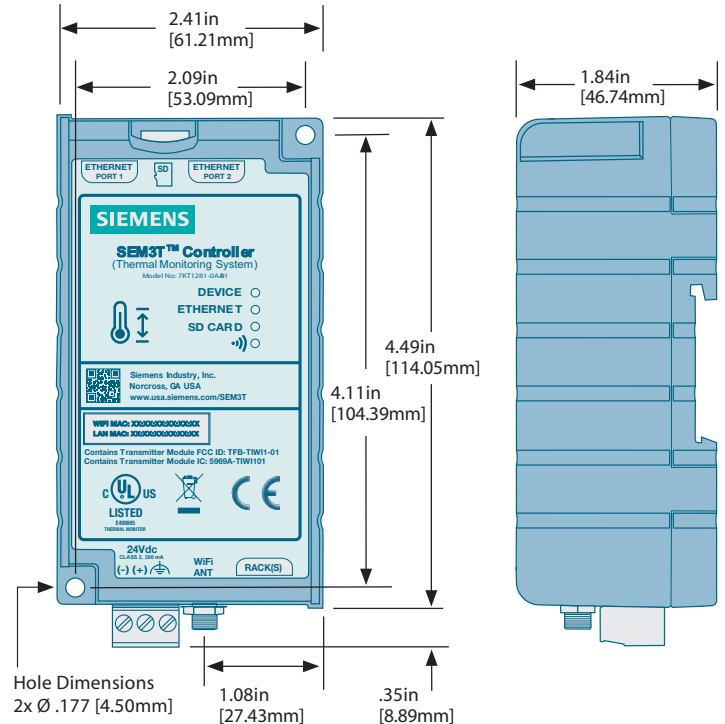

SEM3T Thermal Module

Ordering information

Part	Catalogue Number
SEM3T Sensor Module	7KT1281-1AA00

Thermal Module

Description	Information
Altitude / Elevation	3000 Meters/9843 Feet
Pollution Degree	3 (UL 61010)
Overvoltage Category	IV (UL 61010)
Operating Temperature Range	-10°C to +65°C / 14°F to 149°F

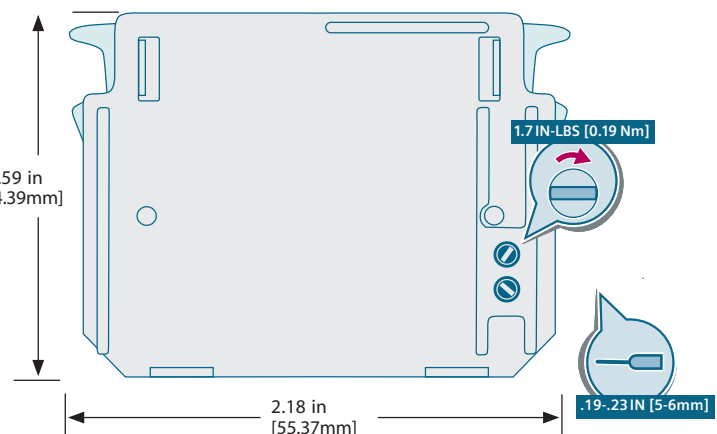
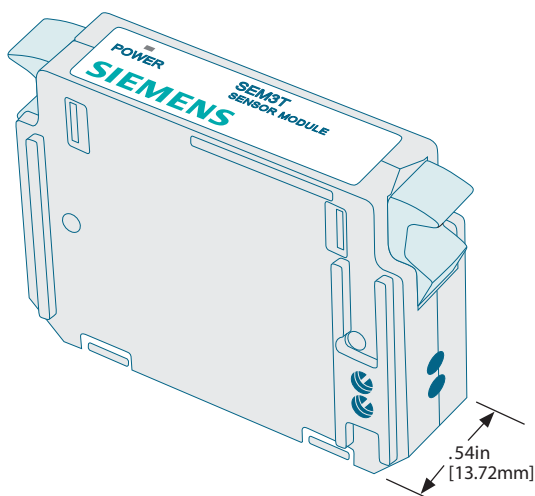

SEM3T Thermal Sensors

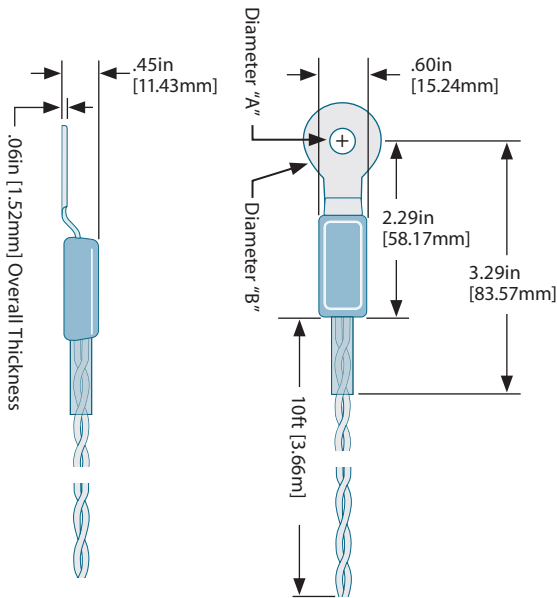

Screw Ring Terminal

Dimensions inches [mm]				Torque (lb-ft) for non-lubricated threads*
Description	Catalogue Number	A	B	
SEM3T sensor 1/4" terminal	7KT1281-2SA00	0.257 [6.527]	0.625 [15.875]	6 - 9
SEM3T sensor 5/16" terminal	7KT1281-2SA01	0.323 [8.204]	1.00 [25.4]	6 - 9
SEM3T sensor 3/8" terminal	7KT1281-2SA02	0.386 [9.804]	1.125 [28.575]	20 - 30
SEM3T sensor 1/2" terminal	7KT1281-2SA03	0.515 [13.081]	1.25 [31.75]	40 - 50

* Example: The SEM3T Sensor 1/4" terminal accepts a 1/4" bolt /screw and the tightening torque is 6-9 lb-ft.

Cylindrical Ring Terminal

Description	Catalogue Number
SEM3T sensor cylindrical	7KT1281-2CA00

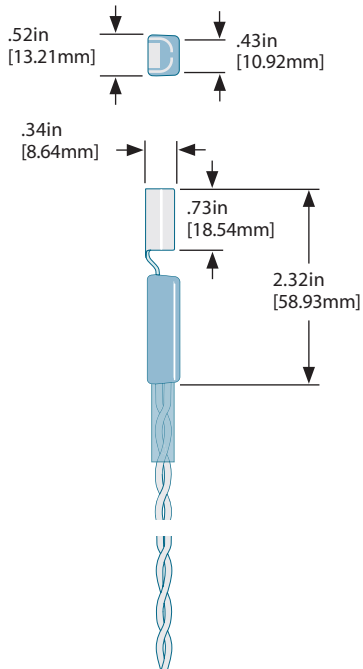

Sensor Information

Description	Information
Altitude / Elevation	3000 Meters/9843 Feet
Pollution Degree	3 (UL 61010)
Overvoltage Category	IV (UL 61010)
Operating Temperature Range	0°C to 130°C / 32°F to 266°F
Wire Type	UL rated operating temperature to 200°C, 600V rated, UL style 1199, 18 AWG, 10x30 stranded

Racks and Cables

Variable Dimensions inches [mm]

Catalogue Number	Description	A	B	C	D
SEM3RACK3	3 position rack	1.90 [48.26]	3.57 [90.68]	2.28 [57.91]	1.79 [45.46]
SEM3RACK6	6 position rack	3.67 [93.22]	5.34 [135.64]	4.05 [102.87]	1.79 [45.46]
SEM3RACK9	9 position rack	5.44 [138.18]	7.07 [179.58]	5.82 [147.83]	1.59 [40.38]
SEM3RACK15	15 position rack	8.98 [228.09]	10.61 [269.49]	9.36 [237.74]	1.59 [40.38]
SEM3RACK21	21 position rack	12.52 [318.01]	14.15 [359.41]	12.90 [327.66]	1.59 [40.38]

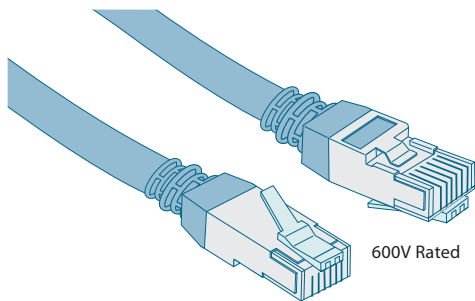
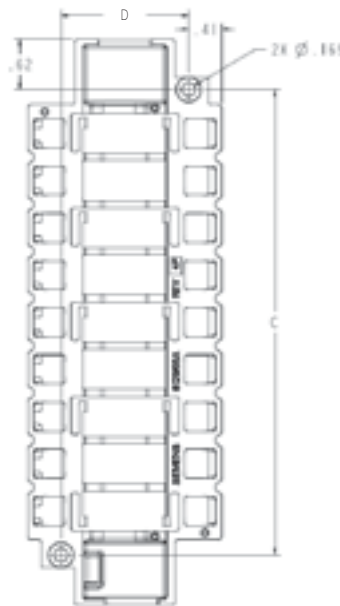
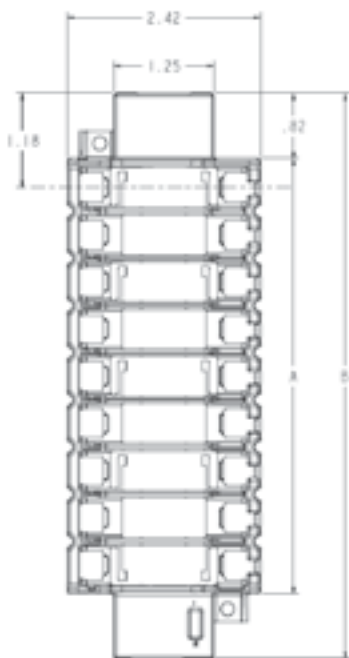





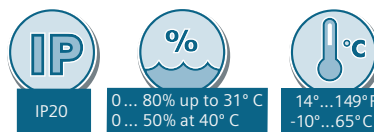

- 6" (152.40 mm) US2:SEM3CAB6INCH
- 12" (304.80 mm) US2:SEM3CAB12INCH
- 24" (609.60 mm) US2:SEM3CAB24INCH
- 36" (914.40 mm) US2:SEM3CAB36INCH

Product Connector Electrical Ratings

Description	Information
Controller Rack Connector	12VDC, 0.5A max
Sensor	5VDC, 0.14mA max
Module	12VDC, 12mA max
Rack - Ethernet Connector	12VDC, 0.5A max
Rack - Module Connector	12VDC, 12mA max



Order Information

Controller		Catalog Number	
SEM3T Controller with Wi-Fi		7KT1281-0AA10	
SEM3T Controller without Wi-Fi		7KT1281-0AA00	
Thermal Sensor Module			
SEM3T Sensor Module		7KT1281-1AA00	
Thermal Sensors			
SEM3T Sensor Screw Ring Terminal 1/4"		7KT1281-2SA00	
SEM3T Sensor Screw Ring Terminal 5/16"		7KT1281-2SA01	
SEM3T Sensor Screw Ring Terminal 3/8"		7KT1281-2SA02	
SEM3T Sensor Screw Ring Terminal 1/2"		7KT1281-2SA03	
SEM3T Sensor Cylindrical Ring Terminal		7KT1281-2CA00	
Accessories			
SEM3T Wi-Fi Antenna and Cable		7KT1281-8AN00	
Meter Racks			
Module Rack 3 Position		SEM3RACK3	
Module Rack 6 Position		SEM3RACK6	
Module Rack 9 Position		SEM3RACK9	
Module Rack 15 Position		SEM3RACK15	
Module Rack 21 Position		SEM3RACK21	
Cables			
Controller to Rack Cable - 6 inch		SEM3CAB6INCH	
Controller to Rack Cable - 12 inch		SEM3CAB12INCH	
Controller to Rack Cable - 24 inch		SEM3CAB24INCH	
Controller to Rack Cable - 36 inch		SEM3CAB36INCH	
Controller to Rack Cable - 5 Foot		SEM3CAB5FT	
Controller to Rack Cable - 10 Foot		SEM3CAB10FT	
Controller to Rack Cable - 20 Foot		SEM3CAB20FT	

Powermanager

A power management system that can be customized to your needs. View and control your facilities' infrastructure condition from anywhere.



Cost allocation and Sub-billing Reports

Cost allocation and sub-billing functionality in the Powermanager software allows the user to track energy related costs by building, floor, tenant, feeder or location. Match virtually any fixed rate billing structure and use comprehensive multi-year scheduling and time-of-use features to manage the energy costs.

Load Studies and Asset Management

Trend power usage data to take full advantage of your electrical distribution system capacity and avoid over-design. Create usage profiles that will allow you to distribute loads and avoid demand peak which helps to identify energy leaks such as equipment running during down time.

Equipment Monitoring and Control

Powermanager allows you to meter all your utilities including gas, steam, air and water and set up general condition alarming and pre-event alarms for impending or imminent conditions. Interface with other energy management and SCADA systems through multiple communication channels and protocols like OPC.

Reports

Standard reports provide models of daily electricity usage so you can distribute loads and avoid demand peaks. This enables you to allocate energy consumption and/or costs to individual areas and identify expensive processes that need attention. The historic trending report compiles data from load circuits over a users predefined period. This enables the user to fully utilize the power distribution system and run at near rated tolerances.

Ordering information

Powermanager Software V4.x and greater versions - Device Licenses	Catalogue Number
POWERMANAGER BASIC 10 DEVICES	7KN27102CE400YC0
POWERMANAGER 20 ADTNL.DEVICES	7KN27111CE400YC0
POWERMANAGER 50 ADTNL.DEVICES	7KN27112CE400YC0
POWERMANAGER 100 ADTNL.DEVICES	7KN27113CE400YC0
POWERMANAGER 200 ADTNL.DEVICES	7KN27114CE400YC0
POWERMANAGER 500 ADTNL.DEVICES	7KN27115CE400YC0
POWERMANAGER 1000 ADTNL.DEVICES	7KN27116CE400YC0
Powermanager Software V4.x and greater versions - Add Ons and Upgrades	Catalogue Number
POWERMANAGER OPT PACKAGE EXPERT	7KN27120CE400YC0
POWERMANAGER OPT PACKAGE CLIENT (2)	7KN27121CE400YC0
POWERMANAGER OPT PACKAGE CLIENT (5)	7KN27122CE400YC0
POWERMANAGER OPT PACKAGE 1 x DISTR SYS	7KN27124CE400YC0

Contact Siemens for upgrade information

SENTRON Powermanager software, combined with Siemens power meters and low-voltage protective devices, provides a complete energy management solution for your business. It allows you to measure, process, analyze, store and share energy usage and status information across your entire enterprise. It offers control capabilities, comprehensive energy usage and reliability, and detailed reporting that will help you reduce energy related costs.

Benefits

- Visibility and control of power flows
- Exact knowledge of the consumption profile
- Increase of energy efficiency
- Optimization of power supply contracts
- Compliance with contractual terms or regulations
- Allocation of costs to individual cost centers
- Optimization of plant maintenance
- Identification of critical systems conditions

The Powermanager software:

- Is available in a stand-alone or LAN/WAN based configuration that can also exchange information with other supervisory systems like building automation software
- Can utilize any Ethernet or serial based connections
- Is expandable from the basic monitoring application to a fully customized enterprise management system
- Is fully scalable with regard to the connected devices and to the software's function to meet current and future needs
- Ensures the seamless integration of power monitoring devices from the Siemens SENTRON PAC Series Meter, SEM3, and SENTRON WL/VL/3VA circuit breakers as well as other Modbus communicating devices
- Is designed to collect, archive, monitor, display and evaluate any kind of energy related device data
- Provides web based reporting and detailed graphics construction utilities as standard

WinPM.Net Enhanced Web-Enabled Energy Management Software



WinPM.Net is a complete energy information management solution for your business allowing you to process, analyze, store and share energy usage and power quality data across your entire enterprise. It offers control capabilities, comprehensive power quality and reliability analysis and can help you reduce energy-related costs. WinPM.net allows you to manage intelligent metering and protective devices, analyze data, and decide on new courses of action to help you save money and keep your business up and running.

Its cutting-edge flexibility and compatibility means you can add one piece at a time, at your own pace, while still maintaining your original investments. Interface to your existing systems through industry-standard protocols and choose newer components as they become available.

The WinPM.Net software:

- Provides detailed analysis of the power quality and overlays waveforms to correlate phase-to-phase relationships between voltages and currents and cascading failures
- Pinpoints the sources of transients, harmonics, or sags, whether external or internal to your facility, allowing you to decide on the right corrective actions. By monitoring circuits 24 hours a day, you can develop strategies to avoid interruptions
- Provides a comprehensive graphics utility as standard to build and edit any graphical screen whether it is a standard screen or a customized one. These custom screens can display real-time and historical data, alarms, status indications, meter, relay and third party equipment information
- Supports Modbus RTU, Modbus TCP, ION, XML, OPC, FTP, and PQDIF compliant systems, so you can unify your diverse operations into one system. Interface to other energy management software, or include transducers, PLCs, and RTUs in a WinPM.net network. OPC can extract values from other software databases then combine these values with up-to-date readings from WinPM.net to perform real time calculations
- Offers easy, cost effective and fast system expansion. The system grows as your needs grow. Add one piece at a time, at your own pace, within your own budget

Cost allocation and sub-billing

Track energy-related costs by building, feeder, or tool. Match virtually any billing structure and use comprehensive multi-year scheduling and time-of-use activity profiles.

Load studies and asset management

Trend power usage data to take full advantage of your electrical distribution system capacity and avoid over-design. Create usage profiles so you can distribute loads and avoid demand peak.

Demand and power factor control

Eliminate penalties through automated power factor correction, load shedding, or peak shaving.

Equipment monitoring and control

Meter all your utilities including gas, steam, air and water. Set up alarms for pending problems, pre-alarm on impending or imminent conditions. Interface with other energy management and SCADA systems through multiple communication channels and protocols.

Ordering information

Software	Catalogue Number
WinPM.NET V9.0 DVD New (Includes 5 meter device licenses, 1 Eng Client, 2 Web Clients, New! Dashboards & PQDIF)	3ZS67100CC900BA0
WinPM.NET V9.0 DVD Replacement	3ZS67100CC900BC0
Device License	
WinPM.Net V9.0 9xxx Meter Device License Limit 6 to 50	3ZS68120CC900BA2
WinPM.Net V9.0 9xxx Meter Device License Limit 51 to 100	3ZS68130CC900BA2
WinPM.Net V9.0 9xxx Meter Device License Limit 101 to 1000	3ZS68140CC900BA2
WinPM.Net V9.0 3rd Party device/Modbus/SeaBus Dev. Lic. Limit 1 to 50	3ZS68220CC900BA2
WinPM.Net V9.0 3rd Party device/Modbus/SeaBus Dev. Lic. Limit 51 to 100	3ZS68230CC900BA2
WinPM.Net V9.0 3rd Party device/Modbus/SeaBus Dev. Lic. Limit 101 to 1000	3ZS68240CC900BA2
Options	
WinPM.Net V9.0 Engineering Client License Limit 2 to 50	3ZS67220CC900BA2
WinPM.Net V9.0 Engineering Client License Limit 51 to 100	3ZS67230CC900BA2
WinPM.Net V9.0 Web Client License	3ZS67420CC900BA2
WinPM.Net V9.0 OPC Server License	3ZS67520CC900BA2
WinPM.NetSQL Server 2017 - 2 CORE License increment (***) Minimum of 4 cores per server is required (2 x 3ZS67317CC900BA0 minimum))	3ZS67317CC900BA0
Software upgrade	
Contact your local SIEMENS D&CES Business Developer for ordering information & upgrade. Allows remote configuration of base WinPM.Net software. Excel is required for excel base reports using Reporter. Outlook is required for e-mailing reports.	

Digitalization for Smart Infrastructure



Cloud & IIoT Solution Offerings

The Siemens Digital Solutions & Services team offers a complete portfolio of digitally enabled products that provide access to data for customers to manage and monitor their assets, as well as analytical insights into their electrical infrastructure.

Provides:

- Edge Connectivity for Cloud Applications
- Plug & Play for Siemens LP Products
- Simplified Dashboarding of Connected Assets
- Mobile, Tablet, & Desktop Compatible
- Multiple Data Export Options
- MindSphere Enabled

Edge Data Collection Unit (DCU)

- Collects field-level device data and stores locally at the edge
- Predefined asset model for automatic configuration of MindSphere assets
- Custom Dashboarding of live data
- Dual Ethernet ports for local and external networks
- Easily connect and monitor standard modbus devices
- Standard device drivers for LP equipment::
 - PAC Power Meters
 - ACCESS Power Meters
 - SEM3
 - 3WL, 3VA, 3VL
- Energy usage and cost breakdown for sub-billing
- One-time or scheduled data export via FTP, USB, and Email
- On-board storage options with or without local display

Cloud Connectivity and Applications

Data aggregated in the Edge DCU can be pushed to an external server or cloud platform for long-term storage. The Edge DCU also offers greater flexibility in configuring and creating a hierarchy of your assets. By doing configuration at the local level and pushing this structure to cloud platforms, such as MindSphere, it removes the need of programming the traditional MindConnect devices in the cloud, transferring the configuration files to USB, before loading directly onto hardware. Cloud connectivity empowers customers to realize value from their data by giving them access to their data outside of their facility. This allows customer to interact with their data using



applications built by Siemens experts, or develop new applications for specific requirements. Using the Siemens cloud applications, users have the ability to choose and change displays to the specific metrics of interest, view and compare time-series data of similar devices, and configure and export reports.

Services



Advantages to You...

- Technical experts
- Single source supplier
- Available 24/7, 365 days a year
- Reduced total cost of ownership (TCO)
- Avoid unscheduled downtime with preventive maintenance

Service Products

Modular service products enable you to customize a technical service agreement to meet your organization's maintenance needs over the entire life cycle of your installation. Including Service products in your TSA will provide the following benefits:

- Substantial savings versus "on demand" purchases
- Optimized scaling of your maintenance organization
- Assurance that your installation is operating at maximum performance and availability

Telephone and Internet

Priority support

When you need help right now, choose the support coverage that fits your business:

24 hours x 7 days a week

8 hours x 5 days a week

Extended support

With extended support, you can request blocks of support hours for specific projects and tasks. We can customize this support service to meet your individual needs.

Remote service

Remote service provides support and diagnostics via data line to save you time and money. Technical support specialists directly access your system for real-time troubleshooting to provide maximum uptime.

Technical account liaison

A technical account liaison provides consulting and guidance on all aspects of support through familiarity with the application, your business goals and processes, and your maintenance and engineering staff.

In addition to a site visit to assess your installation and support requirements, the technical account liaison will conduct monthly reviews with your staff to ensure you are receiving maximum payback on your investment.

Field services

Block of hours

Purchase field service hours in 40 hour increments for preventative, predictive or emergency services.

Maintenance programs

Packaged maintenance programs available for:

- System performance checks
- Run diagnostics
- Analyze power quality
- Visual inspections of key system components
- Database trim and backup

Training

Operation and maintenance

Siemens training offers a broad range of educational services, providing quality and excellence to the automation industry. Targeted product and system training provides the student with practical, hands-on experience.

Customized on-site training

On-site training is excellent for large groups or when individual, one-on-one instruction is needed. When the trainer visits your facility, product training will be conducted on your specific installation. Classroom lectures, and troubleshooting techniques specific to your installation are covered in detail during the training session.

Software update service

The software update service enables you to take advantage of enhancements to the most current software versions. A site evaluation is conducted to determine necessary upgrade requirements prior to the Software Update Service.

Notes
