

PRODUCT HIGHLIGHT

SIMOTICS servomotors— a competitive comparison

usa.siemens.com/simotics-s

SIMOTICS S-1FK7 and S-1FT7 servomotors are an attractive alternative to Rockwell's MP-series low-inertia servomotors. In the majority of cases, the bolt hole circle diameter (M) dimension is the same. In addition, SIMOTICS servomotors offer many additional features and benefits to the machine builder and the end-user.

SIMOTICS S-series servomotors include decoupled encoder from output shaft

Customer benefits include:

- Removes the requirement to derate motor torque by 10% (i.e. with absolute encoder)
- Insulates the encoder from vibration emanating from load
- Longer encoder lifetime due to reduced thermal and vibration stress

SIMOTICS S-series servomotors include a field replaceable encoder

Customer benefits include:

- Less machine downtime—no need to send the motor to the factory for repair
- No need to remove the entire motor from the machine
- Replace the existing encoder and the machine restored to production in minutes
- Less spare parts inventory is needed

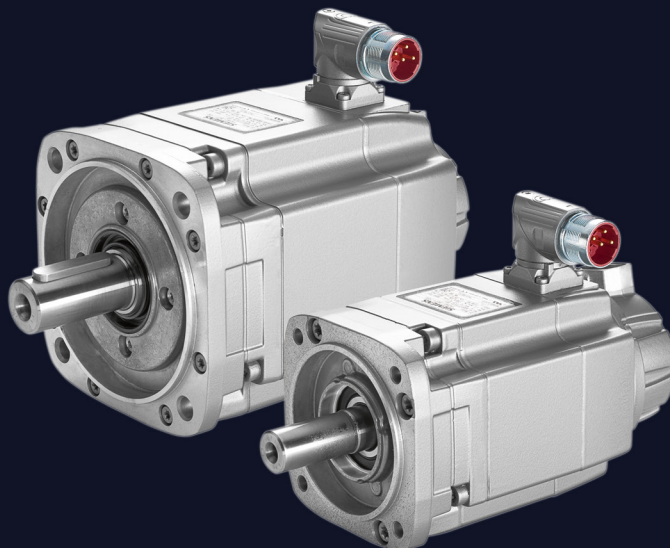

Product
highlight

A SERVOMOTOR COMPARISON GUIDE

Rockwell MPL to Siemens SIMOTICS

The following table documents 400V-class Rockwell MPL servomotor models, each followed by a SIMOTICS counterpart of similar torque and speed performance capacity. Use the table as a guideline for applications in which Rockwell MPL servomotors are currently being used or considered. Use SIZER for Siemens SINAMICS drives per application for thorough evaluation of torque vs. speed characteristics, remainder of servomotor options, servo-drive system and pre-fabricated MOTION-CONNECT cables.

1FK7 and 1FT7 high-dynamic servomotors are especially competitive substitutes for Rockwell MPL (i.e. low-inertia) servomotors due to their similar design of low rotor moment of inertia. A servomotor with low moment of inertia is optimally designed for rapid dynamic response. The dynamic response of 1FK7 and 1FT7 Compact (i.e. medium-inertia) servomotors may be less than with MPL servomotors.

Motor	Rated speed	Rated power	Static torque	Rated torque ¹⁾	Frame size/ shaft height ²⁾	Bolt hole circle diameter (M) ³⁾
	n _{rated} Rpm	P _{rated} kW	M ₀ Nm	M _{rated} Nm	mm	mm
MPL-B1510V	8000	0.16	0.26	0.19	55	63
1FK7022-5AK71-1...	6000	0.38	0.85	0.60	28	63
MPL-B1520U	7000	0.27	0.49	0.37	55	63
1FK7022-5AK71-1...	6000	0.38	0.85	0.60	28	63
MPL-B1530U	7000	0.39	0.9	0.53	55	63
1FK7022-5AK71-1...	6000	0.38	0.85	0.60	28	63
MPL-B210V	8000	0.37	0.55	0.44	70	75
1FK7033-4CK71-1... ⁴⁾	6000	0.6	1.3	0.9	36	75
MPL-B220T	6000	0.62	1.61	0.99	70	75
1FK7033-4CK71-1... ⁴⁾	6000	0.6	1.3	0.9	36	75
MPL-B230P	5000	0.86	2.1	1.64	70	75
1FT7036-5AK71-1...	6000	1.07	3	1.7	36	75
MPL-B310P	5000	0.77	1.58	1.47	89.4	100
1FK7043-4CK71-1... ⁴⁾	6000	1.3	3.5	2	48	100
MPL-B320P	5000	1.5	3.05	2.87	89.4	100
1FT7044-5AK71-1...	4500	1.41	5	3	48	100
MPL-B330P	5000	1.8	4.18	3.44	89.4	100
1FT7044-5AK71-1...	4500	1.41	5	3	48	100
MPL-B420P	5000	1.9	4.74	3.63	98.3	115
1FK7061-4CH71-1... ⁴⁾	4500	2	6.4	4.3	63	130
MPL-B430P	5000	2.2	6.55	4.20	98.3	115
1FK7064-4CH71-1... ⁴⁾	4500	2.4	12	5	63	130
MPL-B4520P	5000	2.1	5.65	4.01	113.7	130
1FK7064-4CH71-1... ⁴⁾	4500	2.4	12	5	63	130
MPL-B4530F	3000	2.1	8.25	6.69	113.7	130
1FK7064-4CF71-1... ⁴⁾	3000	2.5	12	8	63	130
MPL-B4530K	4000	2.6	8.25	6.21	113.7	130
1FK7064-4CH71-1... ⁴⁾	4500	2.4	12	5	63	130

Motor	Rated speed	Rated power	Static torque	Rated torque ¹⁾	Frame size/ shaft height ²⁾	Bolt hole circle diameter (M) ³⁾
	n _{rated} Rpm	P _{rated} kW	M ₀ Nm	M _{rated} Nm	mm	mm
MPL-B4540F	3000	2.6	10.2	8.28	113.7	130
1FK7064-4CF71-1... ⁴⁾	3000	2.5	12	8	63	130
MPL-B4560F	3000	3.2	14.1	10.2	113.7	130
1FT7065-7SF71-1... ⁴⁾	3000	3.8	14	12	63	130
MPL-B520K	3500	3.5	10.7	9.55	143.5	165
1FT7082-5AF71-1...	3000	3.24	13	10.3	80	165
MPL-B540D	2000	3.4	19.4	16.2	143.5	165
1FK7086-4CC71-1... ⁴⁾	2000	3.8	28	18	80	165
MPL-B540K	4000	5.4	19.4	12.9	143.5	165
1FT7086-5AH71-1...	4500	4.71	28	10	80	165
MPL-B560F	3000	5.5	26.8	17.5	143.5	165
1FT7086-5AF71-1...	3000	5.65	28	18	80	165
MPL-B580F	3000	7.1	34	22.6	143.5	165
1FT7085-7SF71-1... ⁴⁾	3000	7.2	34	23	80	165
MPL-B580J	3800	7.9	34	19.9	143.5	165
1FT7085-7SH71-1... ⁴⁾	4500	8.2	34	17.5	80	165
MPL-B640F	3000	6.11	36.7	19.5	184.6	215
1FT7117-7AF71-.... ⁴⁾	3000	9.4	81	30	100	215
MPL-B660F	3000	6.15	48	19.6	184.6	215
1FT7117-7AF71-.... ⁴⁾	3000	9.4	81	30	100	215
MPL-B680D	2000	9.3	62.8	44.4	184.6	215
1FT7117-7AC71-.... ⁴⁾	2000	11.5	78	55	100	215
MPL-B680F	3000	7.5	60	23.9	184.6	215
1FT7117-7AF71-.... ⁴⁾	3000	9.4	81	30	100	215
MPL-B860D	2000	12.5	83	59.7	235	265
1FT7132-5AC71-1...	2000	11.52	90	55	132	300
MPL-B880C	1500	12.6	110	80.2	235	265
1FT7134-5AB71-1...	1500	12.88	118	82	132	300
MPL-B880D	2000	12.6	110	60.2	235	265
1FT7134-5AC71-1...	2000	13.82	118	66	132	300
MPL-B960B	1200	12.7	130	101.1	266.7	300
1FT7138-5AB71-....	1500	16.96	170	108	132	300
MPL-B960C	1500	14.8	124.3	94.2	266.7	300
1FT7136-5AB71-....	1500	14.45	140	92	132	300
MPL-B960D	2000	15	124.3	71.6	266.7	300
1FT7136-5AC71-....	2000	14.87	140	71	132	300
MPL-B980B	1000	15.2	162.7	145.2	266.7	300
1FT7138-5AB71-....	1500	16.96	170	108	132	300
MPL-B980C	1500	16.8	158.2	107.0	266.7	300
1FT7138-5AB71-....	1500	16.96	170	108	132	300
MPL-B980D	2000	18.6	158.2	88.8	266.7	300
1FT7134-5SC7-....	2000	33.5	190	160	132	300

¹⁾ MPL motor-rated torque = rated power * 9550 / rated speed

²⁾ MPL motor catalog description is frame size / SIMOTICS motor catalog description is shaft height

³⁾ Diameter of circle intersecting centers of bolt holes (M)

⁴⁾ High-dynamic SIMOTICS servomotor

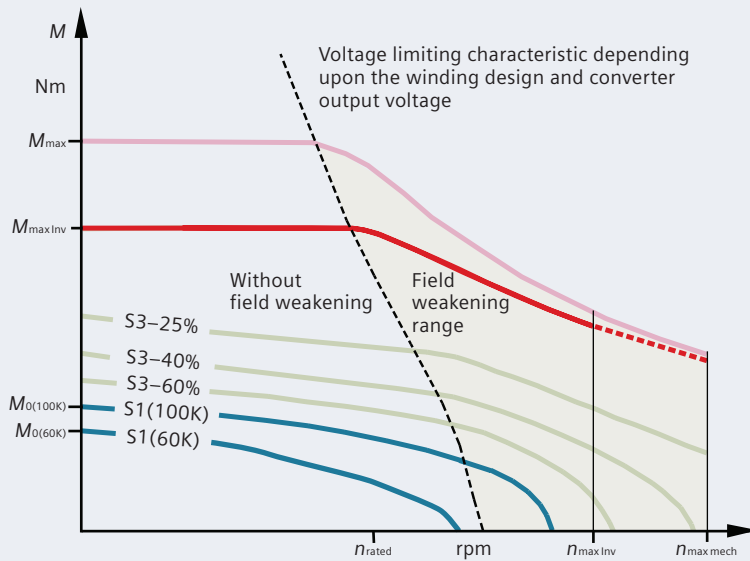

Term and descriptions

n_{rated}	Rated speed	Speed at which M_{rated} is available continuously
$n_{max Inv}$	Maximum permissible electric speed limit	Maximum speed before voltage protection module (VPM) is required
$n_{max mech}$	Maximum permissible mechanical speed limit	
M_0	Static (Stall) torque	Continuous torque available with no rotation
M_{rated}	Rated torque	Continuous torque available at n_{rated}
$M_{max Inv}$	Achievable maximum torque with recommended motor module	Maximum torque available with recommended motor module
M_{max}	Maximum permissible torque	
P_{rated}	Rated power	

Servomotor torque-speed curve characteristics

The plot is characterized by two regions. The first is the continuous operating range, bounded by the blue curves in the figure. Within this region, the servomotor can operate at 100% duty cycle. A higher temperature rise tolerance increases the bound of the continuous operating range, as illustrated by the 60K and 100K curves. The typical catalog ratings for servomotors are documented per 100K curve [i.e. S1(100K)].

The second region is the temporarily-permissible peak range, bounded by the red curve in the figure. Within this range, the motor can be operated at lower duty cycles. If the motor is operated in this region at a duty cycle higher than permissible, the motor will overheat, or motor circuitry can be damaged. SIZER for Siemens SINAMICS drives is the optimal tool to properly size a motor and drive per application so that motor capacity is effectively utilized.

Published by
Siemens Industry, Inc.

100 Technology Drive
Alpharetta, GA 30005

Order No. DRPH-MTR01-0822

Printed in USA

© 08.2022 Siemens Industry, Inc.

usa.siemens.com/motioncontrol

This document contains only general descriptions or performance features, which do not always apply in the manner described in concrete application situations or may change as the products undergo further development. Performance features are valid only if they are formally agreed upon when the contract is closed. Siemens is a registered trademark of Siemens AG.

Product names mentioned may be trademarks or registered trademarks of their respective companies. Specifications are subject to change without notice.