



Fig. 5/33 SIPROTEC 7SJ602 multifunction protection relay

Description

The SIPROTEC 7SJ602 is a numerical overcurrent relay which, in addition to its primary use in radial distribution networks and motor protection, can also be employed as backup for line, transformer and generator differential protection. The SIPROTEC 7SJ602 provides definite-time and inverse-time overcurrent protection along with overload and unbalanced-load (negative-sequence) protection for a very comprehensive relay package.

For applications with ground-current detection two versions are available: One version with four current transformer inputs for non-directional earth (ground) fault detection and a second version with three current inputs (2 phase, 1 earth/ground) and one voltage input for directional earth (ground) fault detection.

The flexible communication interfaces are open for modern communication architectures with control systems.

Function overview

Feeder protection

- Overcurrent-time protection
- Sensitive ground-fault detection
- Directional sensitive ground-fault detection
- Displacement voltage
- Disk emulation
- Overload protection
- Breaker failure protection
- Negative-sequence protection
- Cold load pickup
- Auto-reclosure
- Trip circuit supervision

Motor protection

- Starting time supervision
- Locked rotor
- Restart inhibit
- Undercurrent monitoring
- Temperature monitoring

Control functions

- Commands for control of a circuit-breaker
- Control via keyboard, DIGSI 4 or SCADA system

Measuring functions

- Operational measured values I , V
- Power measurement P , Q , S , W_p , W_q
- Slavepointer
- Mean values

Monitoring functions

- Fault event logging with time stamp (buffered)
- 8 oscillographic fault records
- Continuous self-monitoring

Communication interfaces

- System interface
 - IEC 60870-5-103 protocol
 - PROFIBUS-DP
 - MODBUS RTU/ASCII
- Front interface for DIGSI 4

Hardware

- 4 current transformers or
- 3 current + 1 voltage transformers
- 3 binary inputs
- 4 output relays
- 1 live status contact

Overcurrent Protection / 7SJ602

Application

Wide range of applications

The SIPROTEC 7SJ602 is a numerical overcurrent relay which, in addition to its primary use in radial distribution networks and motor protection, can also be employed as backup for feeder, transformer and generator differential protection.

The SIPROTEC 7SJ602 provides definite-time and inverse-time overcurrent protection along with overload and negative sequence protection for a very comprehensive relay package. In this way, equipment such as motors can be protected against asymmetric and excessive loading. Asymmetric short-circuits with currents that can be smaller than the largest possible load currents or phase interruptions are reliably detected.

The integrated control function allows simple control of a circuit-breaker or disconnector (electrically operated/ motorized switch) via the integrated HMI, DIGSI or SCADA.

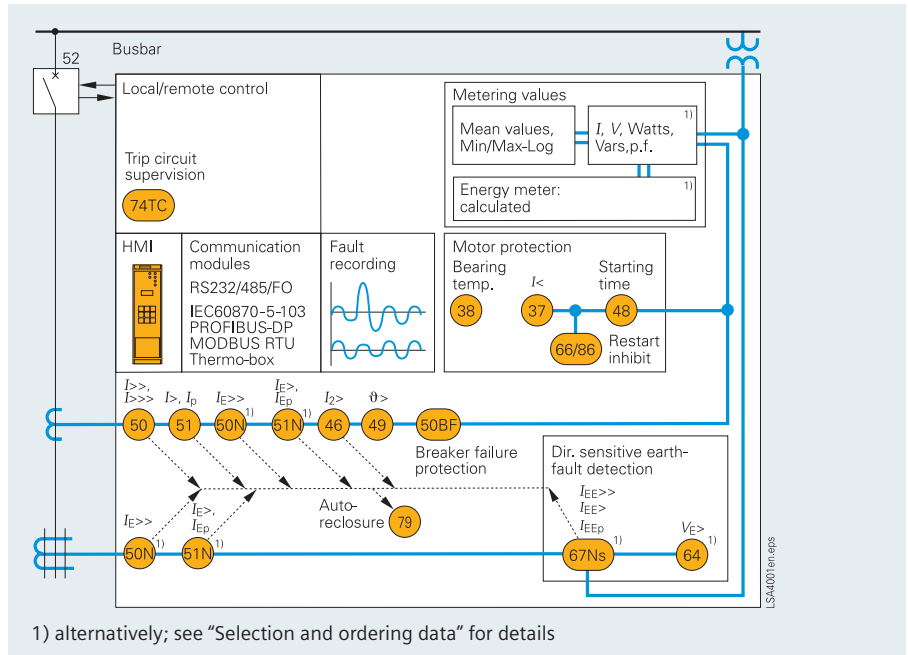

Fig. 5/34 Function diagram

ANSI	IEC	Protection functions
50, 50N	$I_>$, $I_{>>}$, $I_{>>>}$ $I_E>$, $I_{E>>}$	Definite-time overcurrent protection (phase/neutral)
50, 51N	I_p , I_{Ep}	Inverse-time overcurrent protection (phase/neutral)
67Ns, 50Ns	$I_{EE>}$, $I_{EE>>}$, I_{EEp}	Directional/non-directional sensitive ground-fault detection
64	I_2	Displacement voltage
50BF		Breaker failure protection
79		Auto-reclosure
46	$I_2>$	Phase-balance current protection (negative-sequence protection)
49	$\vartheta>$	Thermal overload protection
48		Starting time supervision
66/86		Restart inhibit
37	$I<$	Undercurrent monitoring
38		Temperature monitoring via external device, e.g. bearing temperature monitoring
74TC		Trip circuit supervision breaker control

Construction

The relay contains all the components needed for

- Acquisition and evaluation of measured values
- Operation and display
- Output of signals and trip commands
- Input and evaluation of binary signals
- SCADA interface (RS485, RS232, fiber-optic)
- Power supply.

The rated CT currents applied to the SIPROTEC 7SJ602 can be 1 A or 5 A. This is selectable via a jumper inside the relay.

Two different housings are available. The flush-mounting version has terminals accessible from the rear. The surface-mounting version has terminals accessible from the front. Retrofitting of a communication module, or replacement of an existing communication module with a new one are both possible.

Protection functions

Definite-time characteristics

The definite-time overcurrent function is based on phase-selective evaluation of the three phase currents and ground current.

The definite-time overcurrent protection for the 3 phase currents has a low-set overcurrent element ($I_{>}$), a high-set overcurrent element ($I_{>>}$) and a high-set instantaneous element ($I_{>>>}$). Intentional trip delays can be set from 0 to 60 seconds for all three overcurrent elements.

The definite-time overcurrent protection for the earth (ground) current has a low-set overcurrent element ($I_{E>}$) and a high-set overcurrent element ($I_{E>>}$). Intentional trip delays can be parameterized from 0 to 60 seconds.

Inverse-time characteristics

In addition, inverse-time overcurrent protection characteristics (IDMTL) can be activated.

Reset characteristics

For easier time coordination with electromechanical relays, reset characteristics according to ANSI C37.112 and IEC 60255-3 / BS 142 standards are applied. When using the reset characteristic (disk emulation), a reset process is initiated after the fault current has disappeared.

This reset process corresponds to the reverse movement of the Ferraris disk of an electromechanical relay (thus: disk emulation).



Fig. 5/35 Rear view of flush-mounting housing



Fig. 5/36 View from below showing system interface (SCADA) with FO connection (for remote communications)

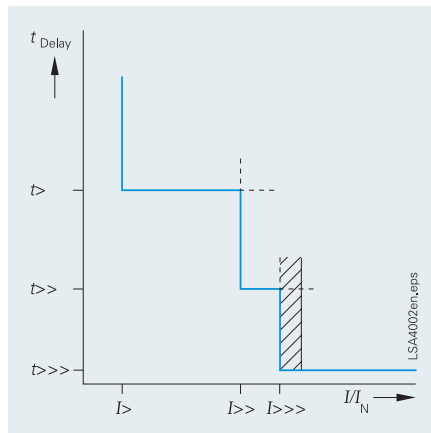

Fig. 5/37 Definite-time overcurrent characteristic

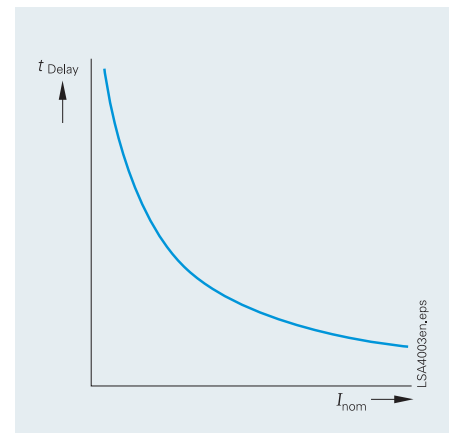

Fig. 5/38 Inverse-time overcurrent characteristic

Available inverse-time characteristics		
Characteristics acc. to	ANSI/IEEE	IEC 60255-3
Inverse	•	•
Short inverse	•	
Long inverse	•	•
Moderately inverse	•	
Very inverse	•	•
Extremely inverse	•	•
Definite inverse	•	
I squared T	•	
R1/RD-type		

Overcurrent Protection / 7SJ602

Protection functions

(Sensitive) directional ground-fault detection (ANSI 64, 67Ns)

The direction of power flow in the zero sequence is calculated from the zero-sequence current I_0 and zero-sequence voltage V_0 . For networks with an isolated neutral, the reactive current component is evaluated; for compensated networks the active current component or residual resistive current is evaluated. For special network conditions, e.g. high-resistance grounded networks with ohmic-capacitive ground-fault current or low-resistance grounded networks with ohmic-inductive current, the tripping characteristics can be rotated approximately ± 45 degrees (cosine/sinus).

Two modes of ground-fault direction detection can be implemented: tripping or in "signalling only mode".

It has the following functions:

- TRIP via the displacement voltage V_E .
- Two instantaneous elements or one instantaneous plus one inverse characteristic.
- Each element can be set in forward, reverse, or non-directional.

(Sensitive) ground-fault detection (ANSI 50Ns, 51Ns/50N, 51N)

For high-resistance grounded networks, a sensitive input transformer is connected to a phase-balance neutral current transformer (also called core-balance CT).

Thermal overload protection (ANSI 49)

The thermal overload protection function provides tripping or alarming based on a thermal model calculated from phase currents.

The ambient temperature or the temperature of the coolant can be detected serially via an external temperature monitoring box (also called thermo-box). If there is no thermo-box it is assumed that the ambient temperatures are constant.

Thermal overload protection without preload:

For thermal overload protection without consideration of the preload current, the following tripping characteristic applies only when

$$I \geq 1.1 \cdot I_L$$

For different thermal time constants T_L , the tripping time t is calculated in accordance with the following equation:

$$t = \frac{35}{\left(\frac{I}{I_L}\right)^2 - 1} \cdot T_L$$

I = Load current

I_L = Pickup current

T_L = Time multiplier

The reset threshold is above $1.03125 \cdot III_N$

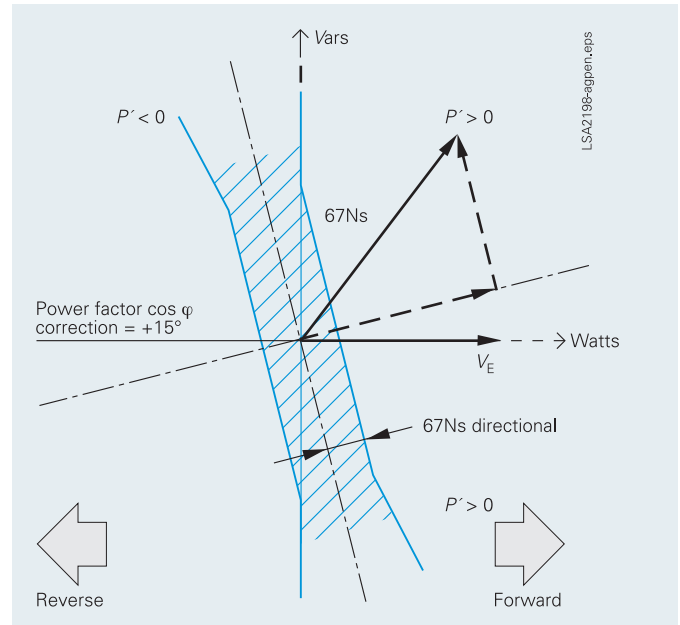

Fig. 5/39 Directional determination using cosine measurements

Thermal overload protection with preload

The thermal overload protection with consideration of preload current constantly updates the thermal model calculation regardless of the magnitude of the phase currents. The tripping time t is calculated in accordance with the following tripping characteristic (complete memory in accordance with IEC 60255-8).

$$t = t \cdot \ln \frac{\left(\frac{I}{k \cdot I_N}\right)^2 - \left(\frac{I_{pre}}{k \cdot I_N}\right)^2}{\left(\frac{I}{k \cdot I_N}\right)^2 - 1}$$

t = Tripping time after beginning of the thermal overload

$$t = 35.5 \cdot T_L$$

I_{pre} = Preload current

I = Load current

k = k factor (in accordance with IEC 60255-8)

I_N = Natural logarithm

T_L = Time multiplier

I_N = Rated (nominal) current

Breaker failure protection (ANSI 50BF)

If a faulted portion of the electrical circuit is not disconnected upon issuance of a trip command, another command can be initiated using the breaker failure protection which operates the circuit-breaker, e.g. of an upstream (higher-level) protection relay. Breaker failure is detected if after a trip command, current is still flowing in the faulted circuit. As an option it is possible to make use of the circuit-breaker position indication.

Negative-sequence protection ($I_{2>>}$, $I_{2>}$ /ANSI 46 Unbalanced-load protection)

The negative-sequence protection (see Fig. 5/40) detects a phase failure or load unbalance due to network asymmetry. Interruptions, short-circuits or crossed connections to the current transformers are detected.

Furthermore, low level single-phase and two-phase short-circuits (such as faults beyond a transformer) as well as phase interruptions can be detected.

This function is especially useful for motors since negative-sequence currents cause impermissible overheating of the rotor.

In order to detect the unbalanced load, the ratio of negative phase-sequence current to rated current is evaluated.

I_2 = negative-sequence current

T_{12} = tripping time

Transformer protection

The high-set element permits current coordination where the overcurrent element functions as a backup for the lower-level protection relays, and the overload function protects the transformer from thermal overload. Low-current single-phase faults on the low voltage side that result in negative phase-sequence current on the high-voltage side can be detected with the negative-sequence protection.

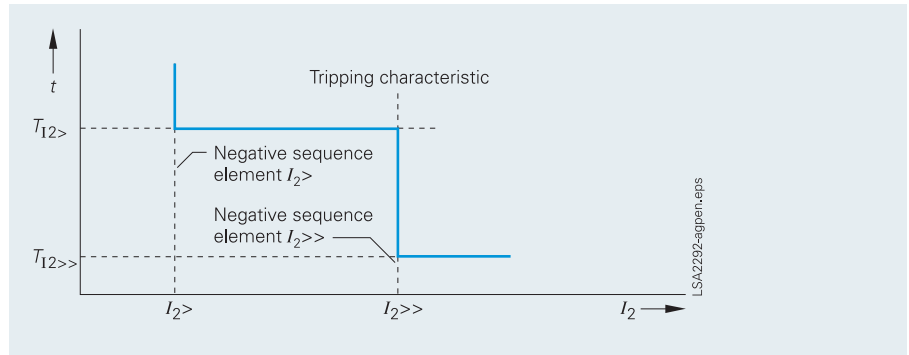

Fig. 5/40 Tripping characteristics of the negative-sequence protection function

Cold load pickup

By means of a binary input which can be wired from a manual close contact, it is possible to switch the overcurrent pickup settings to less sensitive settings for a programmable duration of time. After the set time has expired, the pickup settings automatically return to their original setting. This can compensate for initial inrush when energizing a circuit without compromising the sensitivity of the overcurrent elements during steady state conditions.

3-pole multishot auto-reclosure (AR, ANSI 79)

Auto-reclosure (AR) enables 3-phase auto-reclosing of a feeder which has previously been disconnected by overcurrent protection.

Trip circuit supervision (ANSI 74TC)

One or two binary inputs can be used for trip circuit monitoring.

Control

The relay permits circuit-breakers to be opened and closed without command feedback. The circuit-breaker/disconnector may be controlled by DIGSI, or by the integrated HMI, or by the LSA/SCADA equipment connected to the interface.

Overcurrent Protection / 7SJ602

Protection functions

Switch-onto-fault protection

If switched onto a fault, instantaneous tripping can be effected. If the internal control function is used (local or via serial interface), the manual closing function is available without any additional wiring. If the control switch is connected to a circuit-breaker by-passing the internal control function, manual detection using a binary input is implemented.

Busbar protection (Reverse interlocking)

Binary inputs can be used to block any of the six current stages. Parameters are assigned to decide whether the input circuit is to operate in open-circuit or closed-circuit mode. In this case, reverse interlocking provides highspeed busbar protection in radial or ring power systems that are opened at one point. The reverse interlocking principle is used, for example, in medium-voltage power systems and in switchgear for power plants, where a high-voltage system transformer feeds a busbar section with several medium-voltage outgoing feeders.

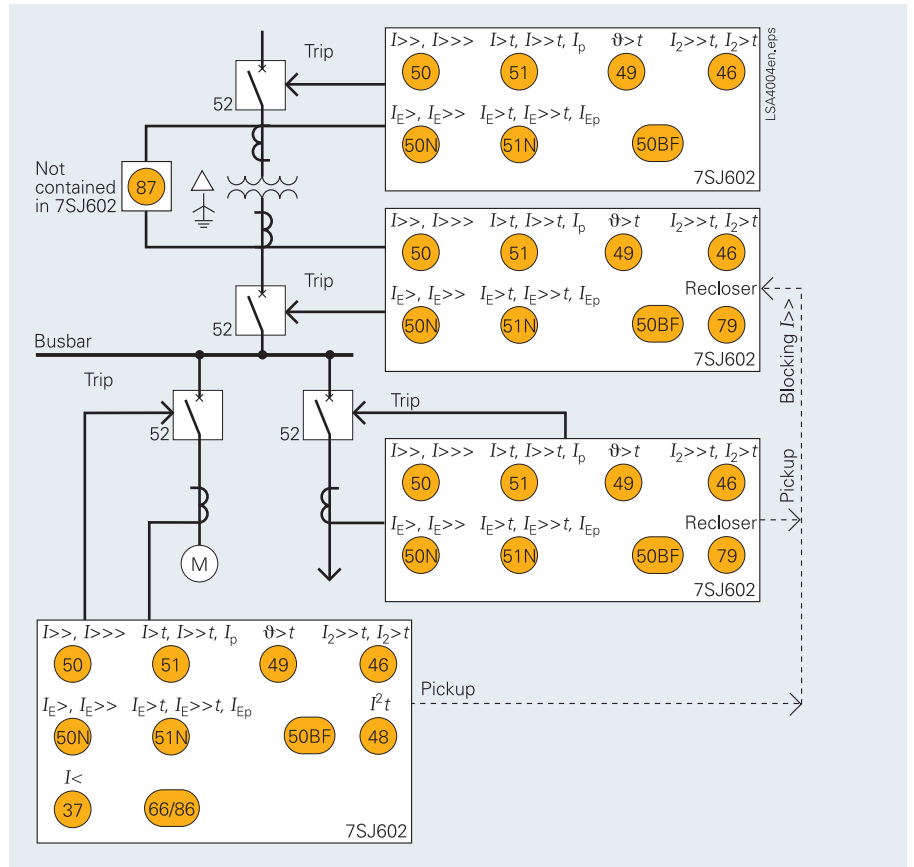

Fig. 5/41 Reserve interlocking

Motor protection

Starting time supervision (ANSI 48)

Starting time supervision protects the motor against long unwanted start-ups that might occur when excessive load occurs, excessive voltage drops occur within the motor or if the rotor is locked. Rotor temperature is calculated from measured stator current. The tripping time is calculated according to the following equation:

$$t_{\text{TRIP}} = \left(\frac{I_{\text{START}}}{I_{\text{rms}}} \right)^2 \cdot t_{\text{start max}}$$

for $I_{\text{rms}} > I_{\text{start}}$, reset ratio $\frac{I_{\text{N}}}{I_{\text{START}}}$ approx. 0.94

t_{TRIP} = tripping time

I_{start} = start-up current of the motor

$t_{\text{start max}}$ = maximum permissible starting time

I_{rms} = actual current flowing

Restart inhibit (ANSI 66/86)

If a motor is started up too many times in succession, the rotor can be subject to thermal overload, especially the upper edges of the bars. The rotor temperature is calculated from the stator current and the temperature characteristic is shown in a schematic diagram. The reclosing lockout only permits startup of the motor if the rotor has sufficient thermal reserves for a complete start-up.

Undercurrent monitoring (ANSI 37)

With this function, a sudden drop in current, which may occur due to a reduced motor load, is detected. This can cause shaft breakage, no-load operation of pumps or fan failure.

Temperature monitoring (ANSI 38)

A temperature monitoring box with a total of 6 measuring sensors can be used for temperature monitoring and detection by the protection relay. The thermal status of motors, generators and transformers can be monitored with this device. Additionally, the temperature of the bearings of rotating machines are monitored for limit value violation. The temperatures are measured with the help of temperature detectors at various locations of the device to be protected. This data is transmitted to the protection relay via a temperature monitoring box (also called thermo-box or RTD-box) (see "Accessories").

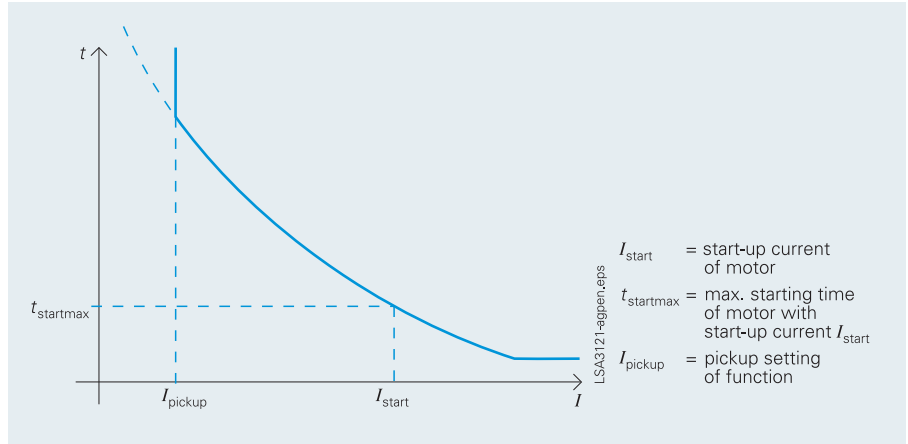

Fig. 5/42 Starting time supervision

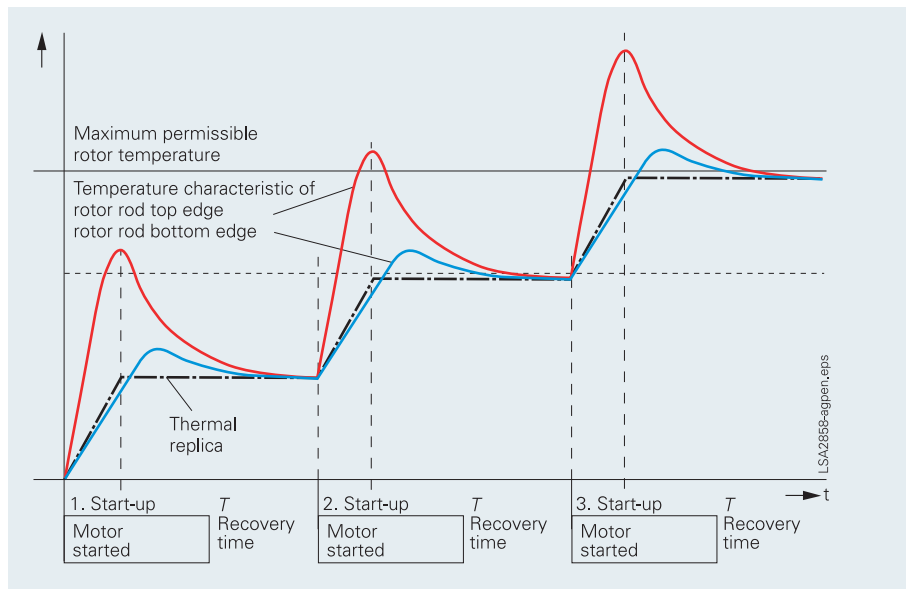

Fig. 5/43 Restart inhibit

Additional functions

Measured values

The r.m.s. values are calculated from the acquired current and voltage along with the power factor, active and reactive power. The following functions are available for measured value processing:

- Currents I_{L1} , I_{L2} , I_{L3} , I_E , I_{EE} (67Ns)
- Voltages V_{L1} , V_E (67Ns if existing)
- Power Watts, Vars, VA/P, Q, S
- Power factor ($\cos \varphi$),
- Energy \pm kWh, \pm kVarh, forward and reverse power flow
- Mean as well as minimum and maximum current, voltage and power values

Overcurrent Protection / 7SJ602

Communication

Communication

With respect to communication, particular emphasis has been placed on high levels of flexibility, data integrity and utilization of standards common in energy automation. The design of the communication modules permits interchangeability.

Local PC interface

The SIPROTEC 7SJ602 is fitted with an RS232 PC front port. A PC can be connected to ease set-up of the relay using the Windows-based program DIGSI which runs under MS-Windows. It can also be used to evaluate up to 8 oscillographic fault records, 8 fault logs and 1 event log containing up to 30 events.

System interface on bottom of the unit

A communication module located on the bottom part of the unit incorporates optional equipment complements and readily permits retrofitting. It guarantees the ability to comply with the requirements of different communication interfaces.

This interface is used to carry out communication with a control or a protection system and supports a variety of communication protocols and interface designs, depending on the module connected.

IEC 60870-5-103 protocol

IEC 60870-5-103 is an internationally standardized protocol for the efficient communication in the protected area. IEC 60870-5-103 is supported by a number of protection device manufacturers and is used worldwide.

PROFIBUS-DP

PROFIBUS-DP is an industry-recognized standard for communications and is supported by a number of PLC and protection device manufacturers.

MODBUS RTU

MODBUS RTU is an industry-recognized standard for communications and is supported by a number of PLC and protection device manufacturers.

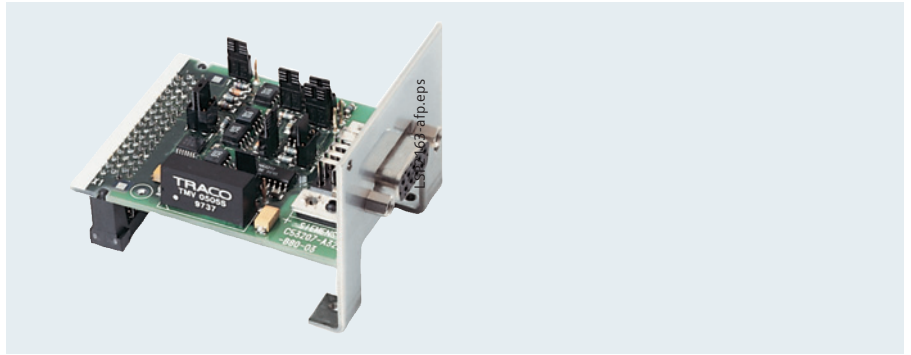

Fig. 5/44 RS232/RS485 electrical communication module

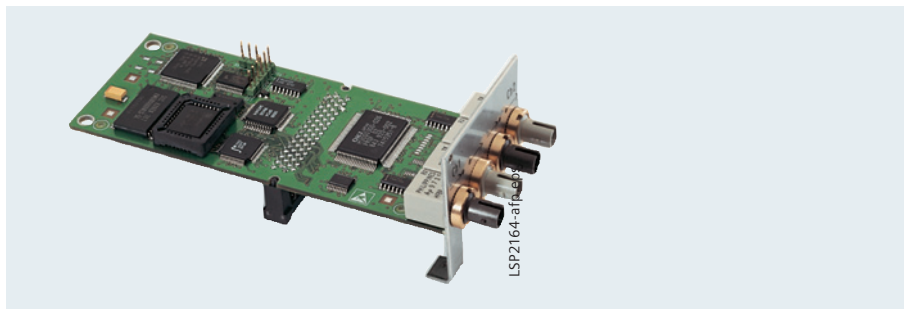

Fig. 5/45 PROFIBUS fiber-optic double ring communication module

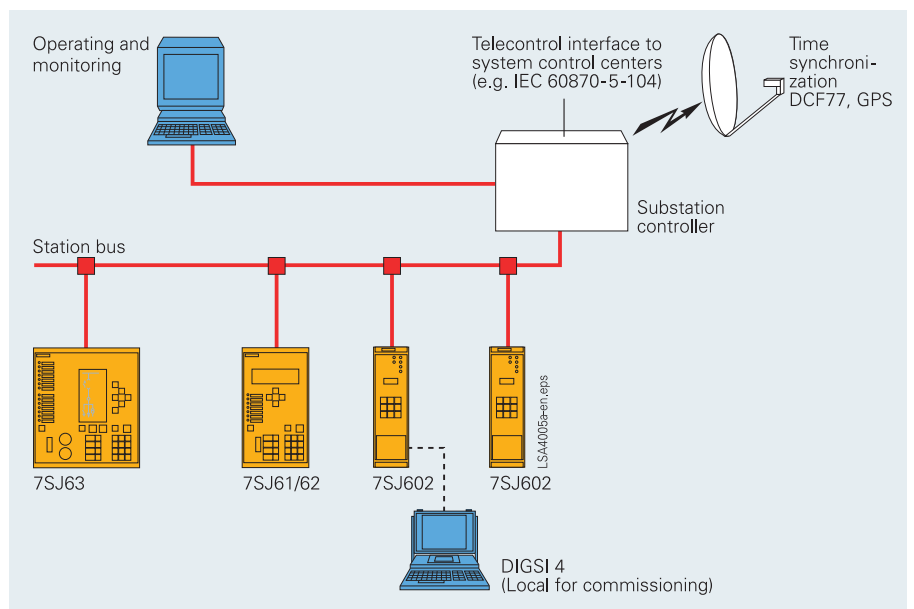

Fig. 5/46 System solution/communication

Typical connections

CT connections

Fig. 5/47 Standard

- Phase current measured
- Ground current measured (e. g. core balance CT)

Fig. 5/48 Standard connection

- Connection of 3 CTs with residual connection for neutral fault

Fig. 5/49 • Isolated networks only

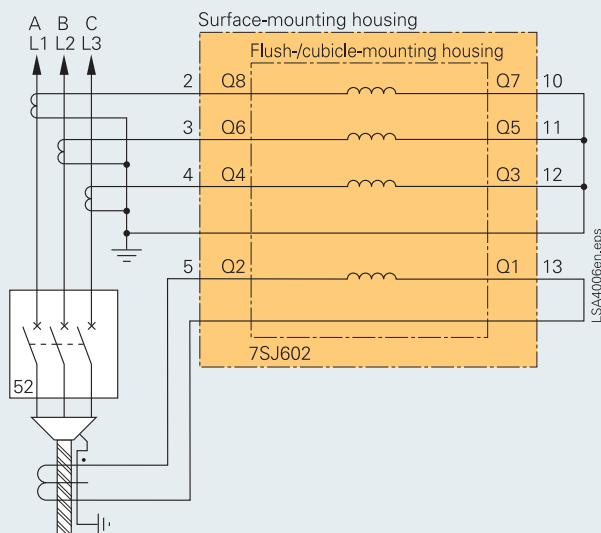

Fig. 5/47 Connection of 4 CTs with measurement of the earth (ground) current

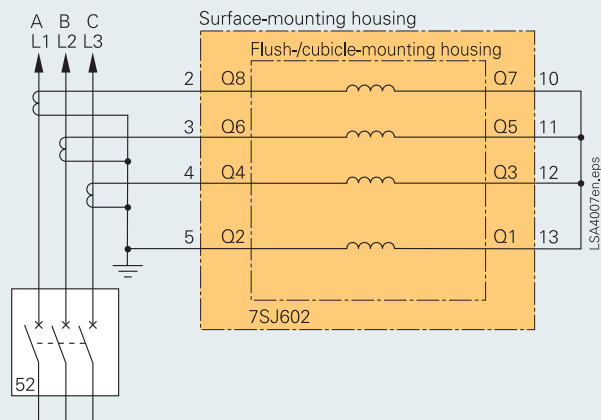

Fig. 5/48 Connection of 3 CTs with residual connection for neutral fault

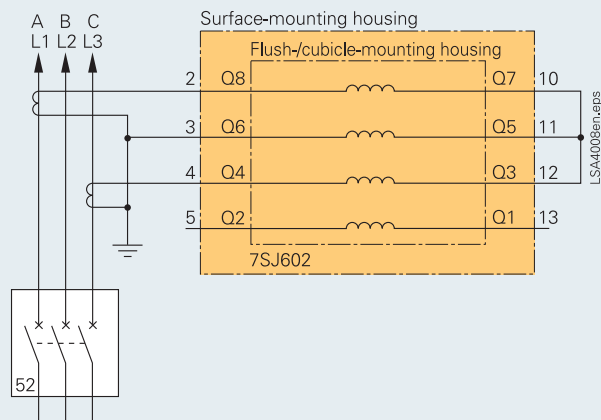

Fig. 5/49 Connection of 2 CTs only for isolated or resonant-earthed (grounded) power systems

Overcurrent Protection / 7SJ602

Typical connections

7SJ6022/7SJ6026

5

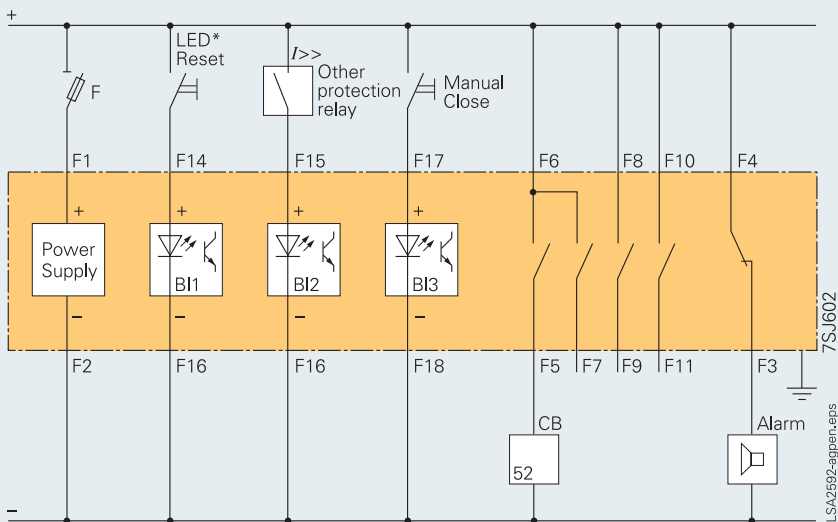
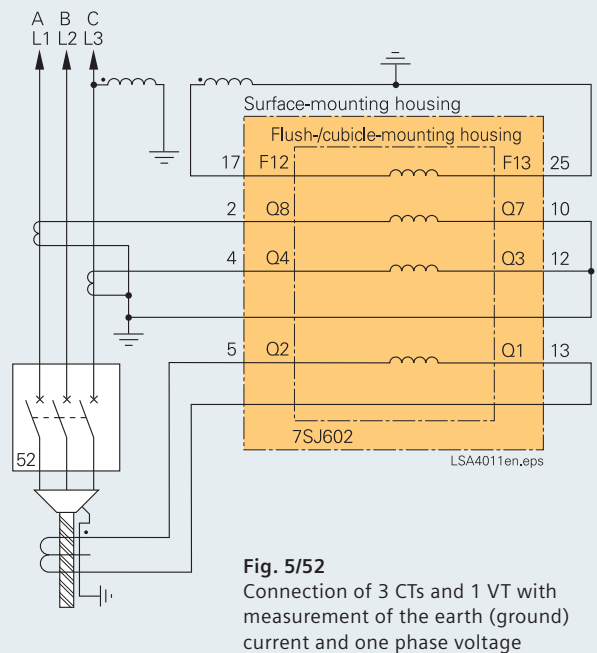
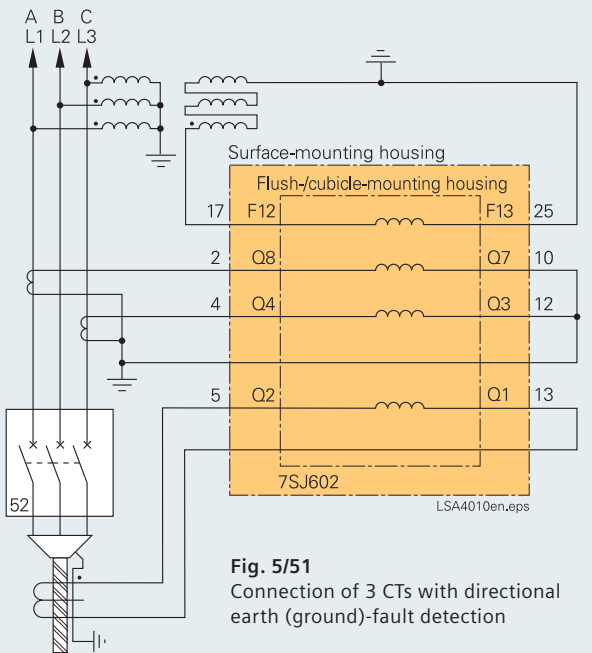
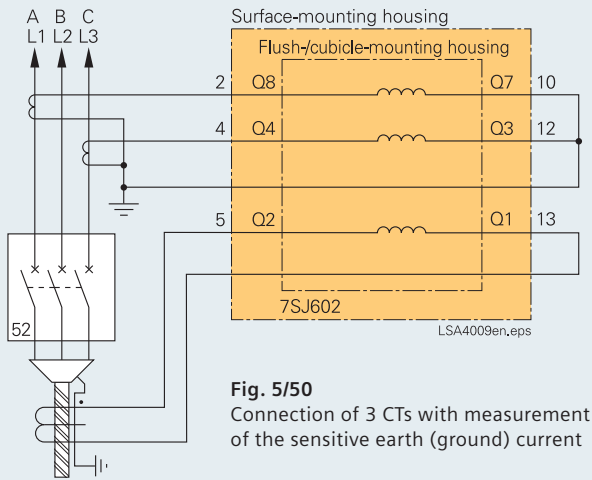

General unit data	
<i>CT circuits</i>	
Rated current I_N	1 or 5 A (settable)
Option: sensitive ground-fault CT	$I_{EE} < 1.6 \text{ A}$ or $< 8 \text{ A}$ (settable)
Rated frequency f_N	50/60 Hz (selectable)
Power consumption	
Current input at $I_N = 1 \text{ A}$	$< 0.1 \text{ VA}$
at $I_N = 5 \text{ A}$	$< 0.3 \text{ VA}$
For sensitive ground-fault detection at 1 A	Approx. 0.05 VA
Overload capability	
Thermal (r.m.s.)	$100 \times I_N$ for 1 s $30 \times I_N$ for 10 s $4 \times I_N$ continuous
Dynamic (pulse current)	$250 \times I_N$ one half cycle
Overload capability if equipped with sensitive ground-fault current transformer	
Thermal (r.m.s.)	300 A for 1 s 100 A for 10 s 15 A continuous
Dynamic (impulse current)	750 A (half cycle)
<i>Voltage transformer</i>	
Rated voltage V_N	100 to 125 V
Power consumption at $V_N = 100 \text{ V}$	$< 0.3 \text{ VA}$ per phase
Overload capability in voltage path (phase-neutral voltage)	
Thermal (r.m.s.)	230 V continuous
<i>Power supply</i>	
Power supply via integrated DC/DC converter	
Rated auxiliary voltage V_{aux} / permissible variations	DC 24/48 V $\pm 20 \%$ DC 60/110 V $\pm 20 \%$ DC 110/125/220/250 V $\pm 20 \%$ AC 115 V/- 20 %, + 15 % AC 230 V/- 20 %, + 15 %
Superimposed AC voltage, peak-to-peak	
At rated voltage	$\leq 12 \%$
At limits of admissible voltage	$\leq 6 \%$
Power consumption	Approx. 3 to 6 W, depending on operational status and selected auxiliary voltage
Bridging time during failure/short-circuit of auxiliary voltage	$\geq 50 \text{ ms}$ at $V_{aux} \geq \text{AC/DC } 110 \text{ V}$ $\geq 20 \text{ ms}$ at $V_{aux} \geq \text{DC } 24 \text{ V}$
<i>Binary outputs</i>	
<i>Trip relays</i>	4 (configurable)
Contacts per relay	1 NO/form A (Two contacts changeable to NC/form B, via jumpers)
Switching capacity	
Make	1000 W/VA
Break	30 VA, 40 W resistive 25 VA with L/R $\leq 50 \text{ ms}$
Switching voltage	250 V
Permissible current	
Continuous	5 A
For 0.5 s	30 A
Permissible total current	
For common potential:	
Continuous	5 A
For 0.5 s	30 A

<i>Alarm relays</i>	1
Contacts per relay	1 NO/NC (form A/B)
Switching capacity	
Make	1000 W/VA
Break	30 VA, 40 W resistive 25 VA with L/R $\leq 50 \text{ ms}$
Switching voltage	250 V
Permissible current	5 A continuous
<i>Binary inputs</i>	
Number	3 (configurable)
Operating voltage	DC 24 to 250 V
Current consumption, independent of operating voltage	Approx. 1.8 mA
Pickup threshold, selectable via bridges	
Rated aux. voltage	
DC 24/48/60/110 V	$V_{pickup} \geq \text{DC } 19 \text{ V}$
DC 110/125/220/250 V	$V_{pickup} \geq \text{DC } 88 \text{ V}$
Permissible maximum voltage	DC 300 V
<i>Connection (with screws)</i>	
Current terminals	
Connection ring cable lugs	$W_{max} = 11 \text{ mm}$, $d_1 = 5 \text{ mm}$ 2.0 – 5.3 mm ² (AWG 14-10)
Wire size	
Direct connection	Solid conductor, flexible lead, connector sleeve
Wire size	2.0 – 5.3 mm ² (AWG 14-10)
Voltage terminals	
Connection ring cable lugs	$W_{max} = 10 \text{ mm}$, $d_1 = 4 \text{ mm}$ 0.5 – 3.3 mm ² (AWG 20-12)
Wire size	
Direct connection	Solid conductor, flexible lead, connector sleeve
Wire size	0.5 – 3.3 mm ² (AWG 20-12)
<i>Unit design</i>	
Housing 7XP20	For dimensions please refer to dimension drawings, part 14
Degree of protection acc. to EN 60529	
For the device	
in surface-mounting housing	IP 51
in flush-mounting housing	
front	IP 51
rear	IP 20
For personal safety	IP 2x with closed protection cover
Weight	
Flush mounting/ cubicle mounting	Approx. 4 kg
Surface mounting	Approx. 4.5 kg
<i>Serial interfaces</i>	
<i>Operating interface</i>	
Connection	At front side, non-isolated, RS232, 9-pin subminiature connector
Operation	With DIGSI 4.3 or higher
Transmission speed	As delivered 19200 baud, parity: 8E1 Min. 1200 baud Max. 19200 baud
Distance	15 m

Overcurrent Protection / 7SJ602

Technical data

5

System interface (bottom of unit)	
<i>IEC60870-5-103 protocol</i>	
Connection	Isolated interface for data transmission
Transmission rate	Min. 1200 baud, max. 19200 baud As delivered 9600 baud
<u>RS232/RS485 acc. to ordered version</u>	
Connection	9-pin subminiature connector on the bottom part of the housing
Test voltage	AC 500 V
RS232 maximum distance	15 m
RS485 maximum distance	1000 m
<u>Fiber-optic</u>	
Connector type	ST connector on the bottom part of the housing
Optical wavelength	$\lambda = 820 \text{ nm}$
Laser class 1 acc. to EN 60825-1/-2	For glass fiber 50/125 μm or 62.5/125 μm
Permissible path attenuation	Max. 8 dB, for glass fiber 62.5/125 μm
Bridgeable distance	Max. 1.5 km
No character position	Selectable, setting as supplied „light off“
<i>PROFIBUS-DP</i>	
Isolated interface for data transfer to a control center	
Transmission rate	Up to 1.5 Mbaud
Transmission reliability	Hamming distance $d = 4$
<u>RS485</u>	
Connection	9-pin subminiature connector
Distance	1000 m/3300 ft $\leq 93.75 \text{ kbaud}$; 500 m/1500 ft $\leq 187.5 \text{ kbaud}$; 200 m/600 ft $\leq 1.5 \text{ Mbaud}$
Test voltage	AC 500 V against ground
<u>Fiber optic</u>	
Connection fiber-optic cable	Integrated ST connector for fiber optic connection
Optical wavelength	$\lambda = 820 \text{ nm}$
Laser class 1 acc. to EN 60825-1-2	For glass fiber 50/125 μm or 62.5/125 μm
Permissible path attenuation	Max. 8 dB, for glass fiber 62.5/125 μm
Distance	500 kB/s 1.6 km/0.99 miles 1500 kB/s 530 m/0.33 miles
Idle state of interface	Settable, setting as supplied „light off“

System interface (bottom of unit), cont'd	
<i>MODBUS RTU/ASCII</i>	
Isolated interface for data transfer to a control center	
Transmission rate	Up to 19200 baud
Transmission reliability	Hamming distance $d = 4$
<u>RS485</u>	
Connection	9-pin subminiature connector
Distance	Max. 1 km/3300 ft max. 32 units recommended
Test voltage	AC 500 V against ground
<u>Fiber-optic</u>	
Connection fiber-optic cable	Integrated ST connector for fiber optic connection
Optical wavelength	820 nm
Laser class 1 acc. to EN 60825-1-2	For glass fiber 50/125 μm or 62.5/125 μm
Permissible path attenuation	Max. 8 dB, for glass fiber 62.5/125 μm
Distance	Max. 1.5 km/0.9 miles
Idle state of interface	„Light off“

Electrical tests	
<i>Specifications</i>	
Standards	IEC 60255-5; ANSI/IEEE C37.90.0
<i>Insulation tests</i>	
High-voltage tests (routine test) all circuits except for auxiliary voltage, binary inputs and communication interfaces	2.5 kV (r.m.s. value), 50 Hz
High-voltage tests (routine test) Auxiliary voltage and binary inputs	DC 3.5 kV
High-voltage tests (routine test) only isolated communication interfaces	500 V (r.m.s. value); 50 Hz
Impulse voltage tests (type test) all circuits, except communication interfaces	5 kV (peak value), 1.2/50 ps, 0.5 J, 3 positive and 3 negative impulses at intervals of 5 s
<i>EMC tests for interference immunity; type tests</i>	
Standards	IEC 60255-6; IEC 60255-22, (product standard) EN 50082-2 (generic standard) DIN 57435 Part 303
High-frequency test IEC 60255-22-1, class III and VDE 0435 Part 303, class III	2.5 kV (peak value); 1 MHz, $\tau = 15 \text{ ms}$; 400 surges per s; test duration 2 s; $R_i = 200 \Omega$
Electrostatic discharge IEC 60255-22-2 class IV EN 61000-4-2, class IV	8 kV contact discharge, 15 kV air gap discharge, both polarities, 150 pF; $R_i = 330 \Omega$
Irradiation with radio-frequency field, non-modulated IEC 60255-22-3 (Report), class III	10 V/m, 27 to 500 MHz
Irradiation with radio-frequency field, amplitude-modulated IEC 61000-4-3, class III	10 V/m, 80 to 1000 MHz, AM 80 %; 1 kHz duration > 10 s
Irradiation with radio-frequency field, pulse-modulated IEC 61000-4-3/ENV 50204, class III	10 V/m, 900 MHz, repetition frequency 200 Hz duty cycle 50 % PM

EMC tests for interference immunity; type tests, (cont'd)	
Fast transients interference/bursts IEC 60255-22-4 and IEC 61000-4-4, class IV	4 kV; 5/50 ns; 5 kHz; burst length = 15 ms; repetition rate 300 ms; both polarities; $R_i = 50 \Omega$; test duration 1 min
Surge voltage IEC 61000-4-5, class III Auxiliary voltage	Pulse: 1.2/50 μ s From circuit to circuit (common mode): 2 kV, 12 Ω , 9 μ F; Across contacts (diff. mode): 1 kV, 2 W, 18 μ F
Measuring inputs, binary inputs/outputs	From circuit to circuit (common mode): 2 kV, 42 Ω , 0.5 μ F; Across contacts (diff. mode): 1 kV, 42 W, 0.5 μ F
Conducted RF amplitude-modulated IEC 61000-4-6, class III	10 V; 150 kHz to 80 MHz; AM 80 %; 1 kHz
Power frequency magnetic field IEC 61000-4-8, class IV IEC 60255-6	30 A/m continuous 300 A/m for 3 s, 50 Hz 0.5 mT, 50 Hz
Oscillatory surge withstand capability ANSI/IEEE C37.90.1	2.5 to 3 kV (peak value), 1 to 1.5 MHz damped wave; 50 surges per s; duration 2 s $R_i = 150$ to 200 Ω ;
Fast transient surge withstand capability ANSI/IEEE C37.90.1	4 to 5 kV, 10/150 ns, 50 surges per s, both polarities; duration 2 s, $R_i = 80 \Omega$;
Radiated electromagnetic interference ANSI/IEEE Std C37.90.2	35 V/m; 25 to 1000 MHz; amplitude and pulse-modulated
Damped wave IEC 60694/ IEC 61000-4-12	2.5 kV (peak value), polarity alternating 100 kHz, 1 MHz, 10 and 50 MHz, $R_i = 200 \Omega$;

EMC tests interference emission; type tests	
Standard	EN 50081-* (generic specification)
Conducted interferences, only auxiliary voltage IEC/CISPR 22	150 kHz to 30 MHz limit class B
Radio interference field strength IEC/CISPR 22	30 to 1000 MHz limit class B
Harmonic currents on incoming lines of system at AC 230 V IEC 61000-3-2	Unit belongs to class D (applies only to units with > 50 VA power consumption)
Voltage fluctuation and flicker range on incoming lines of system at AC 230 V IEC 61000-3-3	Limit values are adhered to

Mechanical stress tests	
Vibration, shock and seismic vibration	
<u>During operation</u>	
Standards	Acc. to IEC 60255-21 and IEC 60068-2
Vibration IEC 60255-21-1, class I IEC 60068-2-6	Sinusoidal 10 to 60 Hz: ± 0.035 mm amplitude; 60 to 150 Hz: 0.5 g acceleration Sweep rate 1 octave/min 20 cycles in 3 orthogonal axes
Shock IEC 60255-21-2, class I	Half-sine, acceleration 5 g, duration 11 ms, 3 shocks in each direction of 3 orthogonal axes
Seismic vibration IEC 60255-21-3, class I IEC 60068-3-3	Sinusoidal 1 to 8 Hz: ± 3.5 mm amplitude (horizontal axis) 1 to 8 Hz: ± 1.5 mm amplitude (vertical axis) 8 to 35 Hz: 1 g acceleration (horizontal axis) 8 to 35 Hz: 0.5 g acceleration (vertical axis) Sweep rate 1 octave/min 1 cycle in 3 orthogonal axes
<u>During transportation</u>	
Standards	Acc. to IEC 60255-21 and IEC 60068-2
Vibration IEC 60255-21-1, class II IEC 60068-2-6	Sinusoidal 5 to 8 Hz: ± 7.5 mm amplitude; 8 to 150 Hz: 2 g acceleration Sweep rate 1 octave/min 20 cycles in 3 orthogonal axes
Shock IEC 60255-21-2, class I IEC 60068-2-27	Half-sine, acceleration 15 g, duration 11 ms; 3 shocks in each direction of 3 orthogonal axes
Continuous shock IEC 60255-21-2, class I IEC 60068-2-29	Half-sine, acceleration 10 g, duration 16 ms, 1000 shocks in each direction of 3 orthogonal axes

Climatic stress tests	
<u>Temperatures</u>	
Recommended temperature During operation	-5 °C to +55 °C / 23 °F to 131 °F, (> 55 °C decreased display contrast)
Limit temperature During operation During storage During transport (Storage and transport with standard works packaging)	-20 °C to +70 °C / -4 °F to 158 °F -25 °C to +55 °C / -13 °F to 131 °F -25 °C to +70 °C / -13 °F to 158 °F
<u>Humidity</u>	
Permissible humidity stress: It is recommended to arrange the units in such a way that they are not exposed to direct sunlight or pronounced temperature changes that could cause condensation.	Annual average: ≤ 75 % relative humidity, on 56 days per year 95 % relative humidity, condensation not permissible!

Overcurrent Protection / 7SJ602

Technical data

5

Functions		Inverse-time overcurrent protection (ANSI 51/51N)	
<i>Definite-time overcurrent protection (ANSI 50, 50N)</i>		<i>Inverse-time overcurrent protection (ANSI 51/51N)</i>	
Setting ranges/steps		Setting ranges/steps	
Low-set overcurrent element		Low-set overcurrent element	
Phase I>	$III_N = 0.1$ to 25 (steps 0.1); or ∞	Phase I_p	$III_N = 0.1$ to 4 (steps 0.1)
Ground $I_{E>}$	$III_N = 0.05$ to 25 (steps 0.01); or ∞	Ground I_{Ep}	$III_N = 0.05$ to 4 (steps 0.01)
High-set overcurrent element		Time multiplier for I_p, I_{Ep} (IEC charac.)	$T_p = 0.05$ to 3.2 s (steps 0.01 s)
Phase I>>	$III_N = 0.1$ to 25 (steps 0.1); or ∞	Time multiplier for I_p, I_{Ep} (ANSI charac.)	$D = 0.5$ to 15 s (steps 0.1 s)
Ground $I_{E>>}$	$III_N = 0.05$ to 25 (steps 0.01); or ∞	High-set overcurrent element	
Instantaneous tripping		Phase I>>>	$III_N = 0.1$ to 25 (steps 0.1); or ∞
Phase I>>>	$III_N = 0.3$ to 12.5 (steps 0.1); or ∞	Ground $I_{E>>>}$	$III_N = 0.05$ to 25 (steps 0.01); or ∞
Delay times T for I>, $I_{E>}$, I>>, $I_{E>>>}$ and I>>>>	0 to 60 s (steps 0.01 s)	Instantaneous tripping	
The set times are pure delay times		Phase I>>>>	$III_N = 0.3$ to 12.5 (steps 0.1); or ∞
Pickup times I>, I>>, $I_{E>}$, $I_{E>>>}$		Delay time $T_{I>>>}$	0 to 60 s (steps 0.01 s)
At 2 x setting value, without meas. repetition	Approx. 25 ms	Tripping time characteristic acc. to IEC	See page 5/33
At 2 x setting value, with meas. repetition	Approx. 35 ms	Pickup threshold	Approx. $1.1 \times I_p$
Pickup times for I>>>> at 2 x setting value	Approx. 15 ms	Reset threshold, alternatively disk emulation	Approx. $1.03 \times I_p$
Reset times I>, I>>, $I_{E>}$, $I_{E>>>}$	Approx. 40 ms	Dropout time	
Reset time I>>>>	Approx. 50 ms	50 Hz	Approx. 50 ms
Reset ratios	Approx. 0.95	60 Hz	Approx. 60 ms
Overshot time	Approx. 55 ms	Tolerances	
Tolerances		Pickup values	5 % of setting value or 5 % of rated value
Pickup values I>, I>>, I>>>>, $I_{E>}$, $I_{E>>>}$	5 % of setting value or 5 % of rated value	Timing period for $2 \leq III_p \leq 20$ and $0.5 \leq III_p \leq 24$	5 % of theoretical value ± 2 % current tolerance; at least 30 ms
Delay times T	1 % of setting value or 10 ms	Influencing variables	
Influencing variables		Auxiliary voltage, range: $0.8 \leq V_{aux}/V_{auxN} \leq 1.2$	≤ 1 %
Auxiliary voltage, range: $0.8 \leq V_{aux}/V_{auxN} \leq 1.2$	≤ 1 %	Temperature, range: $-5^\circ\text{C} \leq \Theta_{amb} \leq 40^\circ\text{C}$ / $-23^\circ\text{F} \leq \Theta_{amb} \leq 104^\circ\text{F}$	≤ 0.5 %/10 K
Temperature, range: $-5^\circ\text{C} \leq \Theta_{amb} \leq 40^\circ\text{C}$ / $23^\circ\text{F} \leq \Theta_{amb} \leq 104^\circ\text{F}$	≤ 0.5 %/10 K	Frequency, range: $0.95 \leq f/f_N \leq 1.05$	≤ 8 %, referred to theoretical time value
Frequency, range: $0.98 \leq f/f_N \leq 1.02$	≤ 1.5 %	Tripping characteristic acc. to ANSI/IEEE	See page 5/33
$0.95 \leq f/f_N \leq 1.05$	≤ 2.5 %	Pickup threshold	Approx. $1.06 \times I_p$
Harmonics		Dropout threshold, alternatively disk emulation	Approx. $1.03 \times I_p$
Up to 10 % of 3 rd harmonic	≤ 1 %	Tolerances	
Up to 10 % of 5 th harmonic	≤ 1 %	Pickup threshold	5 % of setting value or 5 % of rated value
		Timing period for $2 \leq III_p \leq 20$ and $0.5 \leq III_p \leq 24$	5 % of theoretical value ± 2 % current tolerance; at least 30 ms
		Influencing variables	
		Auxiliary voltage, range: $0.8 \leq V_{aux}/V_{auxN} \leq 1.2$	≤ 1 %
		Temperature, range: $-5^\circ\text{C} \leq \Theta_{amb} \leq 40^\circ\text{C}$ / $23^\circ\text{F} \leq \Theta_{amb} \leq 104^\circ\text{F}$	≤ 0.5 %/10 K
		Frequency, range: $0.95 \leq f/f_N \leq 1.05$	≤ 8 %, referred to theoretical time value

<i>(Sensitive) ground-fault protection (directional/non-directional)</i>	
Definite-time ground-fault protection (ANSI 50Ns)	
Setting ranges/steps	
Low-set element $I_{EE>}$	$III_{EEN} = 0.003$ to 1.5 (steps 0.001); or ∞ (deactivated)
High-set element $I_{EE>>}$	$III_{EEN} = 0.003$ to 1.5 (steps 0.001); or ∞ (deactivated)
Delay times T for $I_{EE>}$ and $I_{EE>>}$	0 to 60 s (steps 0.01 s)
Pickup times $I_{EE>}, I_{EE>>}$	
At 2 x setting value without meas. repetition	Approx. 35 ms
At 2 x setting value with meas. repetition	Approx. 55 ms
Reset times $I_{EE>}, I_{EE>>}$	
At 50 Hz	Approx. 65 ms
At 60 Hz	Approx. 95 ms
Reset ratios	Approx. 0.95
Overshot time	Approx. 55 ms
Tolerances	
Pickup values $I_{EE>}, I_{EE>>}$	5 % of setting value or 5 % of rated value
Delay times T	1 % of setting value or 10 ms
Influencing variables	
Auxiliary voltage, range: $0.8 \leq V_{aux}/V_{auxN} \leq 1.2$	$\leq 1 \%$
Temperature, range: $-5 \text{ }^\circ\text{C} \leq \Theta_{amb} \leq 40 \text{ }^\circ\text{C}$ / $23 \text{ }^\circ\text{F} \leq \Theta_{amb} \leq 104 \text{ }^\circ\text{F}$	$\leq 0.5 \%$ /10 K
Frequency, ranges: $0.98 \leq f/f_N \leq 1.02$	$\leq 1.5 \%$
$0.95 \leq f/f_N \leq 1.05$	$\leq 2.5 \%$
Harmonics	
Up to 10 % of 3 rd harmonic	$\leq 1 \%$
Up to 10 % of 5 rd harmonic	$\leq 1 \%$
Inverse-time ground-fault protection (ANSI 51Ns)	
Setting ranges/steps	
Low-set element I_{EEP}	$III_{EEN} = 0.003$ to 1.4 (steps 0.001)
Time multiplier for I_{EEP} (IEC characteristic)	$T_p = 0.05$ to 3.2 s (steps 0.01 s)
Time multiplier for I_{EEP} (ANSI characteristic)	$D = 0.5$ to 15 s (steps 0.1 s)
High-set element $I_{EE>>}$	$III_{EEN} = 0.003$ to 1.5 (steps 0.001); or ∞ (deactivated)
Delay time T for $I_{EE>>}$	0 to 60 s (steps 0.01 s)
Tripping time characteristic acc. to IEC	See page 5/33
Pickup threshold	Approx. $1.1 \times I_{EEP}$
Reset threshold alternatively disk emulation	Approx. $1.03 \times I_{EEP}$
Dropout time	
50 Hz	Approx. 50 ms
60 Hz	Approx. 60 ms
Tolerances	
Pickup values	5 % of setting value or 5 % of rated value
Timing period for $2 \leq III_{EEP} \leq 20$ and $0.5 \leq III_{EEN} \leq 24$	5 % of theoretical value $\pm 2 \%$ current tolerance; at least 30 ms
Influencing variables	
Auxiliary voltage, range: $0.8 \leq V_{aux}/V_{auxN} \leq 1.2$	$\leq 1 \%$

Inverse-time ground-fault protection (ANSI 51Ns), cont'd	
Temperature, range: $-5 \text{ }^\circ\text{C} \leq \Theta_{amb} \leq 40 \text{ }^\circ\text{C}$ / $23 \text{ }^\circ\text{F} \leq \Theta_{amb} \leq 104 \text{ }^\circ\text{F}$	$\leq 0.5 \%$ /10 K
Frequency, range: $0.95 \leq f/f_N \leq 1.05$	$\leq 8 \%$, referred to theoretical time value
Tripping characteristic acc. to ANSI/IEEE	See page 5/33
Pickup threshold	Approx. $1.06 \times I_{EEP}$
Dropout threshold, alternatively disk emulation	Approx. $1.03 \times I_{EEP}$
Tolerances	
Pickup threshold	5 % of setting value or 5 % of rated value
Timing period for $2 \leq III_{EEP} \leq 20$ and $0.5 \leq III_{EEN} \leq 24$	5 % of theoretical value $\pm 2 \%$ current tolerance; at least 30 ms
Influencing variables	
Auxiliary voltage, range: $0.8 \leq V_{aux}/V_{auxN} \leq 1.2$	$\leq 1 \%$
Temperature, range: $-5 \text{ }^\circ\text{C} \leq \Theta_{amb} \leq 40 \text{ }^\circ\text{C}$ / $23 \text{ }^\circ\text{F} \leq \Theta_{amb} \leq 104 \text{ }^\circ\text{F}$	$\leq 0.5 \%$ /10 K
Frequency, range: $0.95 \leq f/f_N \leq 1.05$	$\leq 8 \%$, referred to theoretical time value
Direction detection (ANSI 67Ns)	
Direction measurement	I_E, V_E (measured)
Measuring principle	Active/reactive measurement
Measuring enable	
For sensitive input	$III_{EEN} = 0.003$ to 1.2 (in steps of 0.001 III_{EEN})
Reset ratio	Approx. 0.8
Measuring method	$\cos \varphi$ and $\sin \varphi$
Direction vector	-45° to $+45^\circ$ (in steps of 0.1°)
Dropout delay T_{Reset} Delay	1 to 60 s (steps 1 s)
Angle correction for cable converter (for resonant-grounded system)	In 2 operating points F1 and F2
Angle correction F1, F2	0° to 5° (in steps of 0.1°)
Current values I_1, I_2	
For sensitive input	$III_{EEN} = 0.003$ to 1.6 (in steps of 0.001 III_{EEN})
Measuring tolerance acc. to DIN 57435	2 % of the setting value or 1 mA
Angle tolerance	3°
Displacement voltage (ANSI 64)	
Displacement voltage, measured	$V_E > V_N = 0.02$ to 1.3 (steps 0.001)
Measuring time	Approx. 60 ms
Pickup delay time	0.04 to 320 s or ∞ (steps 0.01 s)
Time delay	0.1 to 40000 s or ∞ (steps 0.01 s)
Dropout ratio	0.95 or (pickup value - 0.6 V)
Measuring tolerance	
V_E (measured)	3 % of setting value, or 0.3 V
Operating time tolerances	1 % of setting value, or 10 ms
The set times are pure delay times	

Overcurrent Protection / 7SJ602

Technical data

5

Thermal overload protection with memory (ANSI 49) with preload		Negative-sequence protection (ANSI 46)	
Setting ranges		Setting ranges/steps	
Factor k according to IEC 60255-8	0.40 to 2 (steps 0.01)	Tripping stages $I_{2>}$ and $I_{2>>}$	8 to 80 % to I_N (steps 1 %)
Thermal time constant τ_{th}	1 to 999.9 min (steps 0.1 min)	Delay times T ($I_{2>}$), T ($I_{2>>}$)	0 to 60 s (steps 0.01 s)
Thermal warning stage $\Theta_{alarm}/\Theta_{trip}$	50 to 99 % referred to trip temperature rise (steps 1 %)	Lower function limit	At least one phase current $\geq 0.1 \times I_N$
Prolongation factor at motor stand-still k_T	1 to 10 (steps 0.01)	Pickup times	at $f_N = 50$ Hz at $f_N = 60$ Hz
Reset ratios		Tripping stages $I_{2>}$ and $I_{2>>}$ But with currents $III_N > 1.5$ (overcurrent case) or negative-sequence current $<$ (set value $+0.1 \times I_N$)	Approx. 60 ms Approx. 75 ms
Θ/Θ_{trip}	Reset below 0.99 Θ_{alarm}		Approx. 200 ms Approx. 310 ms
Θ/Θ_{alarm}	Approx. 0.99	Reset times	
Tolerances		Tripping stages $I_{2>}$ and $I_{2>>}$	Approx. 35 ms Approx. 42 ms
Referring to $k \cdot I_N$	± 5 % (class 5 % acc. to IEC 60255-8)	Reset ratios	
Referring to trip time	± 5 % ± 2 s (class 5 % acc. to IEC 60255-8)	Tripping stages $I_{2>}$ and $I_{2>>}$	Approx. 0.9 to 0.01 $\times I_N$
Influencing variables		Tolerances	
Auxiliary DC voltage, range $0.8 \leq V_{aux}/V_{auxN} \leq 1.2$	≤ 1 %	Pickup values $I_{2>}$, $I_{2>>}$	
Temperature, range $-5^\circ\text{C} \leq \Theta_{amb} \leq +40^\circ\text{C}$ / $23^\circ\text{F} \leq \Theta_{amb} \leq 104^\circ\text{F}$	≤ 0.5 %/10 K	Current $III_N \leq 1.5$	± 1 % of $I_N \pm 5$ % of set value
Frequency, range $0.95 \leq f/f_N \leq 1.05$	≤ 1 %	Current $III_N > 1.5$	± 5 % of $I_N \pm 5$ % of set value
		Delay times T ($I_{2>}$) and T ($I_{2>>}$)	± 1 % but min. 10 ms
		Influencing variables	
		Auxiliary DC voltage, range $0.8 \leq V_{aux}/V_{auxN} \leq 1.2$	≤ 1 %
		Temperature, range $-5^\circ\text{C} \leq \Theta_{amb} + 40^\circ\text{C}$ / $23^\circ\text{F} \leq \Theta_{amb} \leq 104^\circ\text{F}$	≤ 0.5 %/10 K
		Frequency, range $0.98 \leq f/f_N \leq 1.02$	≤ 1 % of I_N
		$0.95 \leq f/f_N \leq 1.05$	≤ 5 % of I_N
Thermal overload protection without memory (ANSI 49) without preload		Auto-reclosure (ANSI 79)	
Setting ranges		Number of possible shots	
Pickup value	$I_L/I_N = 0.4$ to 4 (steps 0.1)	1 to 9, configurable	
Time multiplier t_L (= t_6 -time)	1 to 120 s (steps 0.1 s)	Auto-reclosure modes	
Reset ratio III_L	Approx. 0.94	3-pole	
Tolerances		Dead times for 1 st and any further shot	
Referring to pickup threshold 1.1 I_L	± 5 % of setting value or 5 % of rated value	0.05 s to 1800 s (steps 0.01 s)	
Referring to trip time	± 5 % ± 2 s	Blocking time after successful AR	
Influencing variables		0.05 s to 320 s (steps 0.01 s)	
Auxiliary DC voltage, range $0.8 \leq V_{aux}/V_{auxN} \leq 1.2$	≤ 1 %	Lock-out time after unsuccessful AR	
Temperature, range $-5^\circ\text{C} \leq \Theta_{amb} \leq +40^\circ\text{C}$ / $23^\circ\text{F} \leq \Theta_{amb} \leq 104^\circ\text{F}$	≤ 0.5 %/10 K	0.05 s to 320 s (steps 0.01 s)	
Frequency, range $0.95 \leq f/f_N \leq 1.05$	≤ 1 %	Reclaim time after manual close	
		0.50 s to 320 s (steps 0.01 s)	
		Duration of reclose command	
		0.01 s to 60 s (steps 0.01 s)	
Breaker failure protection		Trip circuit supervision (ANSI 74TC)	
Setting ranges/steps		Trip circuit supervision	
Pickup of current element	CB $I>/I_N = 0.04$ to 1.0 (steps 0.01)	With one or two binary inputs	
Delay time	0.06 to 60 s or ∞ (steps 0.01 s)	Circuit-breaker trip test	
Pickup times (with internal start) (via control) (with external start)	is contained in the delay time is contained in the delay time is contained in the delay time	Trip/reclosure cycle	
Dropout time	Approx. 25 ms	Control	
Tolerances		Number of devices	
Pickup value	2 % of setting value	1	
Delay time	1 % or 20 ms	Evaluation of breaker contact	
		None	

Motor protection	
Setting ranges/steps Rated motor current/ transformer rated current	$I_{\text{motor}}/I_N = 0.2 \text{ to } 1.2$ (in steps of 0.1)
Start-up current of the motor	$I_{\text{start}}/I_{\text{motor}} = 0.4 \text{ to } 20$ (in steps of 0.1)
Permissible start-up time $t_{\text{start max}}$	1 to 360 s (in steps of 0.1 s)
Starting time supervision (ANSI 48)	
Setting ranges/steps Pickup threshold	$I_{\text{pickup}}/I_{\text{motor}} = 0.4 \text{ to } 20$ (in steps of 0.1)
Tripping time characteristic	$t_{\text{TRIP}} = \left(\frac{I_{\text{start}}}{I_{\text{rms}}} \right)^2 \cdot t_{\text{start max}}$ For $I_{\text{rms}} > I_{\text{pickup}}$ I_{start} = Start-up current of the motor I_{rms} = Current actually flowing I_{pickup} = Pickup threshold, from which the motor start-up is detected $t_{\text{start max}}$ = Maximum permissible starting time t_{TRIP} = Tripping time
Reset ratio $I_{\text{rms}}/I_{\text{pickup}}$	Approx. 0.94
Tolerances Pickup values	5 % of setting value or 5 % rated value
Delay time	5 % or 330 ms
Restart inhibit for motors (ANSI 66/86)	
Setting ranges/steps Rotor temperature compensation time T_{COMP}	0 to 60 min (in steps of 0.1 min)
Minimum restart inhibit time T_{restart}	0.2 to 120 min (in steps of 0.1 min)
Maximum permissible number of warm starts n_w	1 to 4 (in steps of 1)
Difference between cold and warm start $n_c - n_w$	1 to 2 (in steps of 1)
Extension factor for cooling simulation of the rotor (running and stop)	1 to 10 (in steps of 0.1)
Restarting limit	$\Theta_{\text{restart}} = \Theta_{\text{rot max perm}} \cdot \frac{n_c - 1}{n_c}$ Θ_{restart} = Temperature limit below which restarting is possible $\Theta_{\text{rot max perm}}$ = Maximum permissible rotor overtemperature (= 100 % in operational measured value $\Theta_{\text{rot}}/\Theta_{\text{rot trip}}$) n_c = Number of permissible start-ups from cold state
Undercurrent monitoring (ANSI 37)	
Threshold	$I_L < I_N = 0.1 \text{ to } 4$ (in steps of 0.01)
Delay time for $I_L <$	0 to 320 s (in steps of 0.1 s)

Thermo-box (instead of system interface) (ANSI 38)	
Number of temperature sensors	Max. 6
Type of measuring	Pt 100 Ω or Ni 100 Ω or Ni 120 Ω
Installation drawing	"Oil" or "Environment" or "Stator" or "Bearing" or "Other"
Limit values for indications For each measuring detector	
Warning temperature (stage 1)	-50 °C to 250 °C (in steps of 1 °C) -58 °F to 482 °F (in steps of 1 °F) or ∞ (no indication)
Alarm temperature (stage 2)	-50 °C to 250 °C (in steps of 1 °C) -58 °F to 482 °F (in steps of 1 °F) or ∞ (no indication)

Additional functions	
Operational measured values	
For currents	$I_{L1}, I_{L2}, I_{L3}, I_E$ in A (Amps) primary or in % I_N 10 to 240 % I_N 3 % of measured value
Range Tolerance	
For voltages	V_{L1-E} , in kV primary or in % 10 to 120 % of V_N ≤ 3 % of measured value
Range Tolerance	
For sensitive ground-current detection	$I_{EE}, I_{EEac}, I_{EEreac}$ (r.m.s., active and reactive current) in A (kA) primary, or in % 0 to 160 % I_{EEN} ≤ 3 % of measured value
Range Tolerance	
Power/work	
S Apparent power	in kVA, MVA, GVA
S/VA (apparent power)	For $V/V_N, I/I_N = 50 \text{ to } 120$ % typically < 6 %
P Active power, P/Watts (active power)	in kW, MW, GW For $ \cos \phi = 0.707 \text{ to } 1$, typically < 6 %, for $V/V_N, I/I_N = 50 \text{ to } 120$ %
Q Reactive power, Q/Var (reactive power)	In kvar, Mvar, Gvar For $ \sin \phi = 0.707 \text{ to } 1$, typically < 6 %, for $V/V_N, I/I_N = 50 \text{ to } 120$ %
$\cos \phi$, total and phase-selective	-1 to +1
Power factor $\cos \phi$	For $ \cos \phi = 0.707 \text{ to } 1$, typically < 5 %
Metering	
+ W_p kWh - W_p kWh + W_q kvarh - W_q kvarh	In kWh, MWh, GWh forward In kWh reverse In kvarh inductive In kvarh, Mvarh, Gvarh capacitive
Long-term mean values	
Mean values	15, 30, 60 minutes mean values
$I_{L1 \text{ dmd}}$ in A, kA	P_{dmd} in kW
$I_{L2 \text{ dmd}}$ in A, kA	Q_{dmd} in kvar
$I_{L3 \text{ dmd}}$ in A, kA	S_{dmd} in kVA

Overcurrent Protection / 7SJ602

Technical data

5

Min./max. LOG (memory)	
Measured values	With date and time
Reset automatic	Time of day (settable in minutes) Time range (settable in days; 1 to 365, ∞)
Reset manual	Via binary input Via keyboard Via communication
Min./max. values of primary currents	I_{L1} ; I_{L2} ; I_{L3}
Min./max. values of primary voltages	V_{L1-E}
Min./max. values of power	S Apparent Power P Active power Q Reactive power Power factor $\cos \varphi$
Min./max. values of primary currents mean values	I_{L1dmd} , I_{L2dmd} , I_{L3dmd}
Min./max. values of power mean value	P_{dmd} , Q_{dmd} , S_{dmd}
Fault event log	
Storage	Storage of the last 8 faults
Time assignment	
Resolution for operationa indications	1 s
Resolution for fault event indications	1 ms
Max. time deviation	0.01 %
Fault recording	
Storage	Storage of max. 8 fault events
Total storage time (fault detection or trip command = 0 ms)	Max. 5 s, selectable pre-trigger and post-fault time
Max. storage period per fault event T_{max}	0.30 s to 5 s (steps 0.01 s)
Pre-trigger time T_{pre}	0.05 s to 0.50 s (steps 0.01 s)
Post-fault time T_{post}	0.05 s to 0.50 s (steps 0.01 s)
Sampling rate at 50 Hz	1 instantaneous value per ms
Sampling rate at 60 Hz	1 instantaneous value per 0.83 ms
Backup battery	Lithium battery 3 V/1 Ah, type CR 1/2 AA Self-discharge time > 5 years "Battery fault" battery charge warning

CE conformity

This product is in conformity with the Directives of the European Communities on the harmonization of the laws of the Member States relating to electromagnetic compatibility (EMC Council Directive 2004/108/EG previous 89/336/EEC) and electrical equipment designed for use within certain voltage limits (Council Directive 2006/95/EG previous 73/23/EEC).

This unit conforms to the international standard IEC 60255, and the German standard DIN 57435/Part 303 (corresponding to VDE 0435/Part 303).

The unit has been developed and manufactured for application in an industrial environment according to the EMC standards.

This conformity is the result of a test that was performed by Siemens AG in accordance with Article 10 of the Council Directive complying with the generic standards EN 50081-2 and EN 50082-2 for the EMC Directive and standard EN 60255-6 for the "low-voltage Directive".



Overcurrent Protection/7SJ602

Selection and ordering data

Description	Order No.	
7SJ602 multifunction overcurrent and motor protection relay	7SJ602 <input type="checkbox"/> - <input type="checkbox"/> <input type="checkbox"/> <input type="checkbox"/> <input type="checkbox"/> <input type="checkbox"/> <input type="checkbox"/> <input type="checkbox"/> - <input type="checkbox"/> <input type="checkbox"/> <input type="checkbox"/> <input type="checkbox"/> <input type="checkbox"/> <input type="checkbox"/> <input type="checkbox"/> <input type="checkbox"/> <input type="checkbox"/> <input type="checkbox"/> <input type="checkbox"/> <input type="checkbox"/> <input type="checkbox"/> <input type="checkbox"/>	
Measuring inputs (4 x I), default settings		
$I_N = 1A^1$, 15 th position only with A	1	
$I_N = 5A^1$, 15 th position only with A	5	
Measuring inputs (1 x V, 3 x I), default settings		
$I_{ph} = 1A^1$, I_e = sensitive ($I_{EE} = 0.003$ to 1.5 A), 15 th position only with B and J	2	
$I_{ph} = 5A^1$, I_e = sensitive ($I_{EE} = 0.015$ to 7.5 A), 15 th position only with B and J	6	
Auxiliary voltage		
DC 24/48 V, binary input threshold DC 19 V	2	
DC 60/110 V ²⁾ , binary input threshold DC 19 V ³⁾	4	
DC 110/125/220/250 V, AC 115/230 V ²⁾ binary input threshold 88 V ³⁾	5	
Unit design		
Surface-mounting housing, terminals on top and bottom	B	
Flush-mounting housing, screw-type terminals	E	
Region-specific default and language settings		
Region World, 50/60 Hz, ANSI/IEC characteristic, languages: English, German, French, Spanish, Russian	B	
System port (on bottom of unit)		
No system port	0	
IEC 60870-5-103, electrical RS232	1	
IEC 60870-5-103, electrical RS485	2	
IEC 60870-5-103, optical 820 nm, ST connector	3	
Temperature monitoring box, electrical RS485 ⁴⁾	8	
PROFIBUS-DP Slave, electrical RS485	9	
PROFIBUS-DP Slave, optical 820 nm, double ring, ST connector	9	
MODBUS, electrical RS485	9	
MODBUS, optical 820 nm, ST connector	9	
		L 0 A
		L 0 B
		L 0 D
		L 0 E
Command (without process check back signal)		
Without command	0	
With command	1	
Measuring/fault recording		
Oscillographic fault recording	1	
Oscillographic fault recording, slave pointer, mean values, min./max. values	3	

See next page

1) Rated current can be selected by means of jumpers.
 2) Transition between the two auxiliary voltage ranges can be selected by means of jumpers.
 3) The binary input thresholds can be selected in two stages by means of jumpers.
 4) Temperature monitoring box 7XV5662-□AD10, refer to part 13.

Overcurrent Protection / 7SJ602

Selection and ordering data

ANSI No.	Description	Order No.
7SJ602 multifunction overcurrent and motor protection relay		7SJ602□-□□□□□-□□□□
Basic version		
50/51	Overcurrent protection TOC phase $I>$, $I>>$, $I>>>$, I_p , reverse interlocking	
50N/51N	Earth/ground-fault protection TOC ground/earth $I_{E>}$, $I_{E>>}$, I_{Ep}	
49	Thermal overload protection	
74TC	Trip-circuit supervision	
50BF	Circuit-breaker failure protection	
	Cold load pickup	
46	Negative-sequence system overcurrent protection	F A 1)
Basic version + directional earth/ground-fault detection		
50/51	Overcurrent protection TOC phase $I>$, $I>>$, $I>>>$, I_p , reverse interlocking	
67Ns	Directional sensitive earth/ground-fault detection $I_{EE>}$, $I_{EE>>}$, I_{Ep}	
64	Sensitive ground-fault protection	
49	Thermal overload protection	
74TC	Trip-circuit supervision	
50BF	Circuit-breaker failure protection	
	Cold load pickup	
46	Negative-sequence system overcurrent protection	F B 2)
Basic version + sensitive earth/ground-fault detection + measuring		
50/51	Overcurrent protection TOC phase $I>$, $I>>$, $I>>>$, I_p , reverse interlocking	
50Ns/51Ns	Sensitive earth/ground-fault detection $I_{EE>}$, $I_{EE>>}$, I_{Ep}	
49	Thermal overload protection	
74TC	Trip-circuit supervision	
50BF	Circuit-breaker failure protection	
	Cold load pickup	
46	Negative-sequence system overcurrent protection	
	Voltage and power measuring	F J 2)
Basic version + motor protection		
50/51	Overcurrent protection TOC phase $I>$, $I>>$, $I>>>$, I_p , reverse interlocking	
50N/51N	Earth/ground-fault protection TOC ground/earth $I_{E>}$, $I_{E>>}$, I_{Ep}	
49	Thermal overload protection	
74TC	Trip circuit supervision	
50BF	Circuit-breaker failure protection	
	Cold load pickup	
46	Negative-sequence system overcurrent protection	
48	Start-time supervision	
37	Undercurrent/loss of load monitoring	
66/86	Restart inhibit	H A 1)
Basic version + directional ground/earth fault protection + motor protection		
50/51	Overcurrent protection TOC phase $I>$, $I>>$, $I>>>$, I_p , reverse interlocking	
67Ns	Sensitive ground fault detection for systems with resonant or isolated $I_{EE>}$, $I_{EE>>}$, I_{Ep}	
64	Displacement voltage	
49	Thermal overload protection	
74TC	Trip circuit supervision	
50BF	Circuit-breaker failure protection	
	Cold load pickup	
46	Negative-sequence system overcurrent protection	
48	Start-time supervision	
37	Undercurrent/loss of load monitoring	
66/86	Restart inhibit	H B 2)
Basic version + sensitive ground/earth-fault detection + measuring + motor protection		
50/51	Overcurrent protection TOC phase $I>$, $I>>$, $I>>>$, I_p , reverse interlocking	
50Ns/51Ns	Sensitive ground/earth-fault detection $I_{EE>}$, $I_{EE>>}$, I_{Ep}	
49	Thermal overload protection	
74TC	Trip circuit supervision	
50BF	Circuit-breaker failure protection	
	Cold load pickup	
46	Negative-sequence system overcurrent protection	
	Voltage and power measuring	
48	Start-time supervision	
37	Undercurrent/loss of load monitoring	
66/86	Restart inhibit	H J 2)
Auto-reclosure (ARC)		
	Without auto-reclosure ARC	0
79	With auto-reclosure ARC	1

1) Only with position 7 = 1 or 5

2) Only with position 7 = 2 or 6

Overcurrent Protection/7SJ602

Selection and ordering data

Accessories	Description	Order No.
	DIGSI 4 Software for configuration and operation of Siemens protection units running under MS Windows 2000/XP Professional Edition, device templates, Comtrade Viewer, electronic manual included as well as "Getting started" manual on paper, connecting cables (copper) Basis Full version with license for 10 computers, on CD-ROM (authorization by serial number)	7XS5400-0AA00
	Professional DIGSI 4 Basis and additionally SIGRA (fault record analysis), CFC Editor (logic editor), Display Editor (editor for default and control displays) and DIGSI 4 Remote (remote operation)	7XS5402-0AA00
	SIGRA 4 (generally contained in DIGSI Professional, but can be ordered additionally). Software for graphic visualization, analysis and evaluation of fault records. Can also be used for fault records of devices of other manufacturers (Comtrade format). Running under MS Windows. Incl. templates, electronic manual with license for 10 PCs on CD-ROM. Authorization by serial number.	7XS5410-0AA00
	Temperature monitoring box AC/DC 24 to 60 V	7XV5662-2AD10
	AC/DC 90 to 240 V	7XV5662-5AD10
	Connecting cable (contained in DIGSI 4, but can be ordered additionally) Cable between PC/notebook (9-pin con.) and protection unit (9-pin connector)	7XV5100-4
	Cable between temperature monitoring box and SIPROTEC 4 unit - length 5 m / 16.4 ft - length 25 m / 82 ft - length 50 m / 164 ft	7XV5103-7AA05 7XV5103-7AA25 7XV5103-7AA50
	Manual for 7SJ602 English please visit www.siemens.com/siprotec Spanish please visit www.siemens.com/siprotec	

Accessories	Description	Order No.	Size of package	Supplier
 <p>LSP2093-afp.eps</p> <p>Short-circuit links for current terminals</p>  <p>LSP2289-afp.eps</p> <p>Mounting rail</p>	Terminal safety cover			
	Voltage/current terminal 18-pole	C73334-A1-C31-1	1	Siemens
	Voltage/current terminal 8-pole	C73334-A1-C32-1	1	Siemens
	Short-circuit links For current terminals	C73334-A1-C33-1	1	Siemens
	For other terminals	C73334-A1-C34-1	1	Siemens
	Mounting rail for 19" rack	C73165-A63-D200-1	1	Siemens
	Your local Siemens representative can inform you on local suppliers.			

Overcurrent Protection / 7SJ602

Connection diagram

5

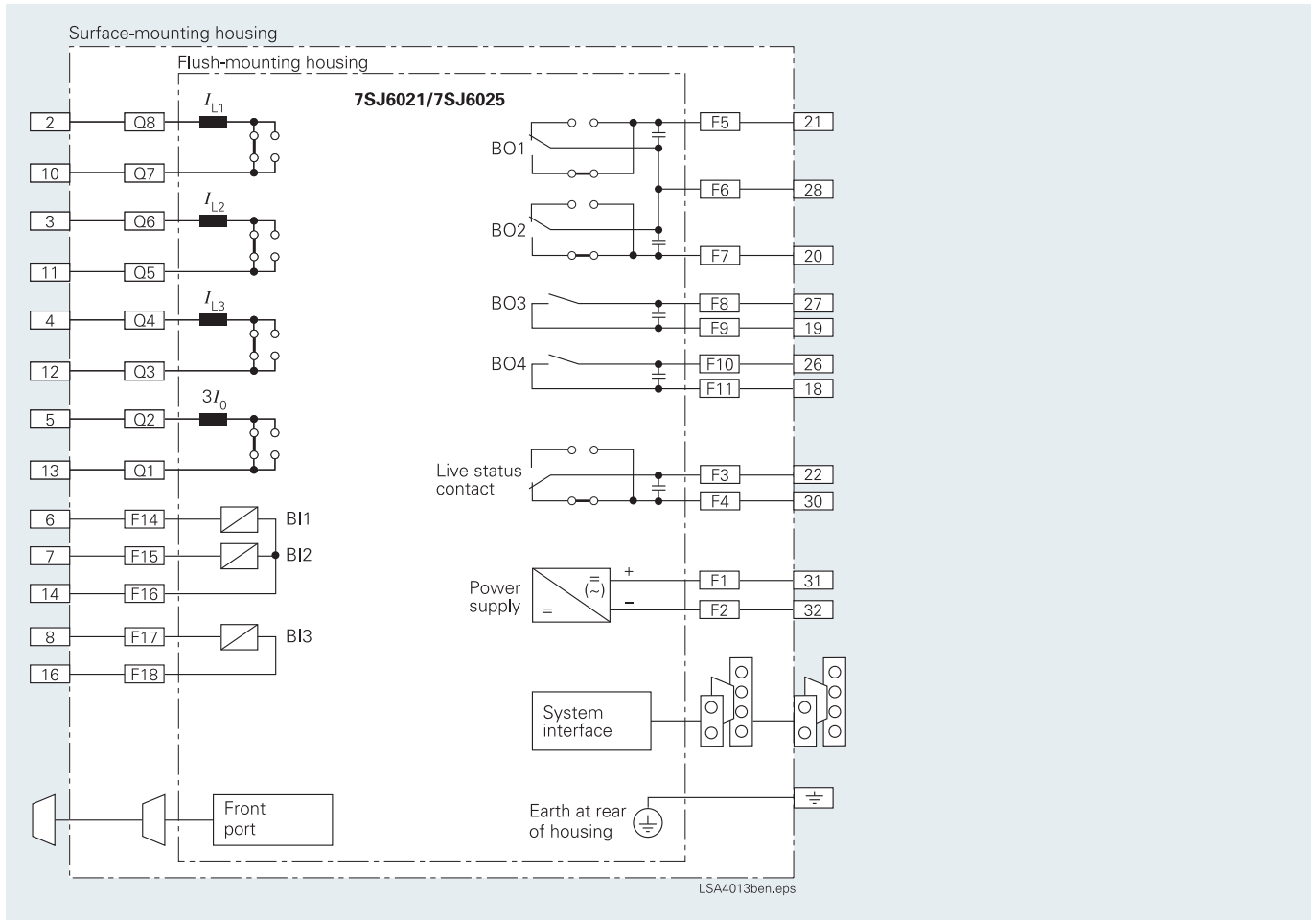

Fig. 5/54 Connection diagram according to IEC standard

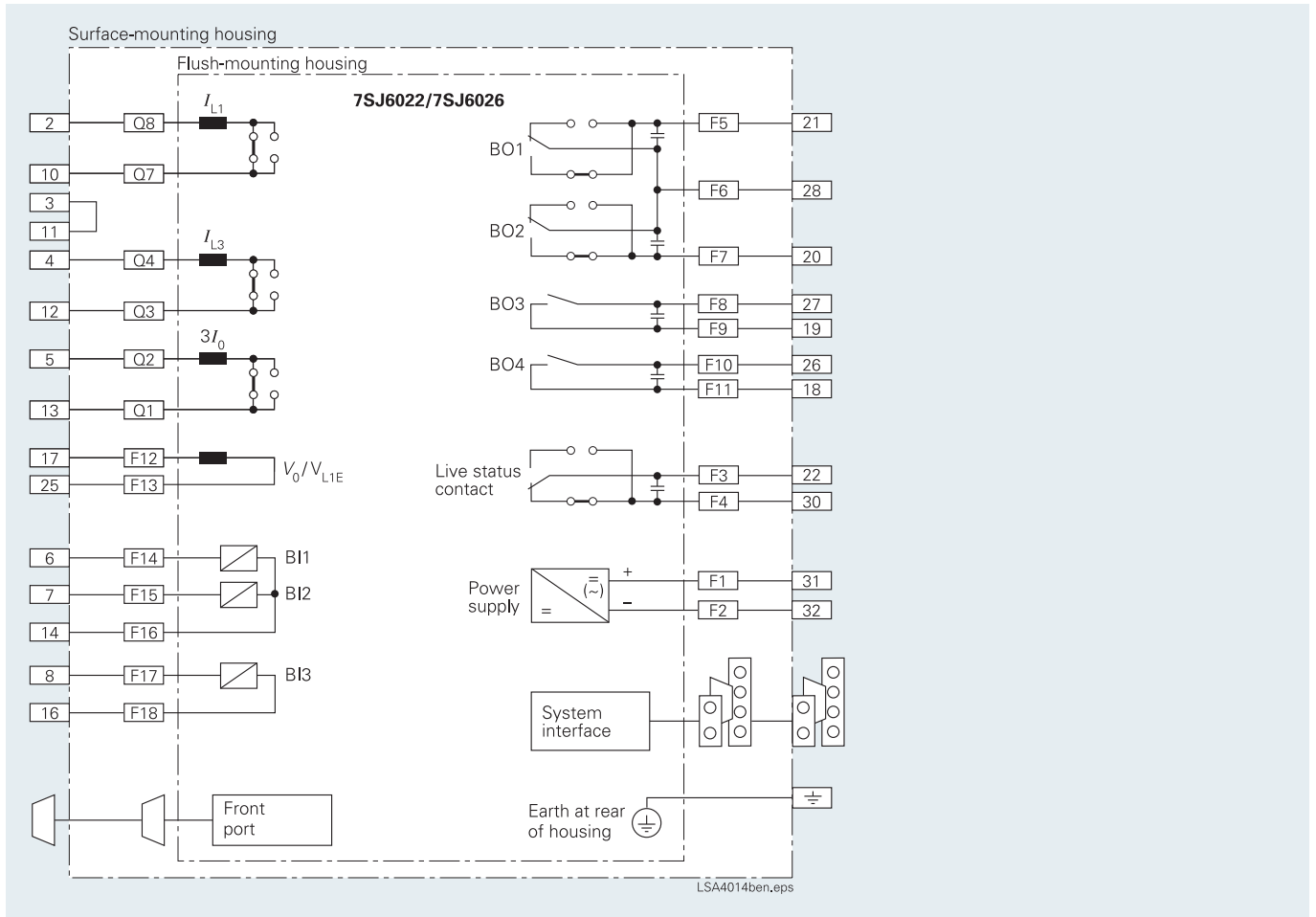

Fig. 5/55 Connection diagram according to IEC standard