

SIEMENS

Ingenuity for life



Protection of Asynchronous Motors with Korndorfer Starter

www.siemens.com/siprotec5

SIPROTEC 5 Application

Protection of Asynchronous Motors with Korndorfer Starter

SIPROTEC 5 Application

Protection of Asynchronous Motors with Korndorfer Starter

APN-033, Edition 1

Content

1	Protection of Asynchronous Motors with Korndorfer Starter.....	3
1.1	Introduction.....	3
1.2	Principle.....	3
1.3	Protection of Motors.....	4
1.4	Differential Protection Versions	5
1.5	Conclusion.....	7

1 Protection of Asynchronous Motors with Korndorfer Starter

1.1 Introduction

During start of a motor the current is significant higher than the nominal current. This peak will load the network, so as in small weak networks it can cause voltage drops.

With a view to the power system conditions, the starting current should be kept low and this is why the motor is started with special starting methods. One method is to start with reduced voltage by means of the so called three switch method or Korndorfer Starter. This method is useable for high voltage motors or motors with large power. The Differential protection is recommended for this type of motors as fast short circuit protection.

This application describes the related adaption of motor protection devices during such start up process.

1.2 Principle

The **Korndorfer starter** is a technique used for reduced voltage soft starting of induction motors. The circuit uses a three-phase autotransformer and three three-phase switches. This motor starting method was invented in 1908, by Max Korndörfer in Berlin.

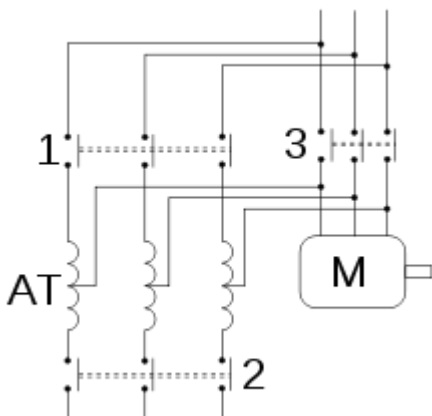

Fig. 1: Korndorfer starter with motor (M), autotransformer (AT) and three switches (1, 2, 3)

If all switches are open the motor is completely disconnected from the three-phase network.

To start the motor, first the switches **1** and **2** are closed. This supplies the motor a lower voltage from the autotransformer. The lower voltage limits the input current to the initially stationary motor, which accelerates. The torque of the motor is also lowered.

The motor continues to increase its speed until the motor torque and the load torque balance each other and a steady speed is achieved. At this stage switch **2** is opened and momentarily the motor is supplied by even lower voltage, because the windings of the autotransformer act as inductors connected in series with motor.

This time is short - just enough to disconnect the switch **2** and engage switch **3**, which connects the full voltage to the motor. Further increase in speed begins and motor reaches its full rated speed.

At this point the "soft start" is ended and motor can work under full load. The autotransformer is no longer required and is de-energized by opening switch **1**.

The motor is supplied directly from the three-phase network. To stop the motor, open switch **3**.

The Korndorfer starter can be used manually. Newer devices provide full automatic operation in a compact version with numerical control system to control the complete startup sequence.

SIPROTEC 5 Applikation

Protection of Asynchronous Motors with Korndorfer Starter

Advantages

The Korndorfer starter limits significantly the inrush current. It is used for large HV motors and for large motors in so called weak networks, in which start by direct connection is not possible.

Heavy load starts are not recommended because of the long starting time.

The most effective ratio of the autotransformer is between 65-80%.

1.3 Protection of Motors

The modular concept of SIPROTEC 5 series ensures the consistency and integrity of all functionalities. Various protection functions that protect a motor against thermal overloading are described in 7SK85 manual and catalog sheets.

As mentioned above the differential protection is used for larger motors as fast and selective short circuit protection.

Still during starting, current transformer saturation can occur due to high starting current, with an extreme rise in the differential current. Reason for this is the DC component in the starting current. Even similar CT's are used the different burden leads to divergent transmission behavior.

With a view to the protection functions the starting process of a motor via auto transformer must be considered in greater detail. It is necessary to check whether the differential current caused by the starting transformer during starting leads to tripping respectively how stabilize it.

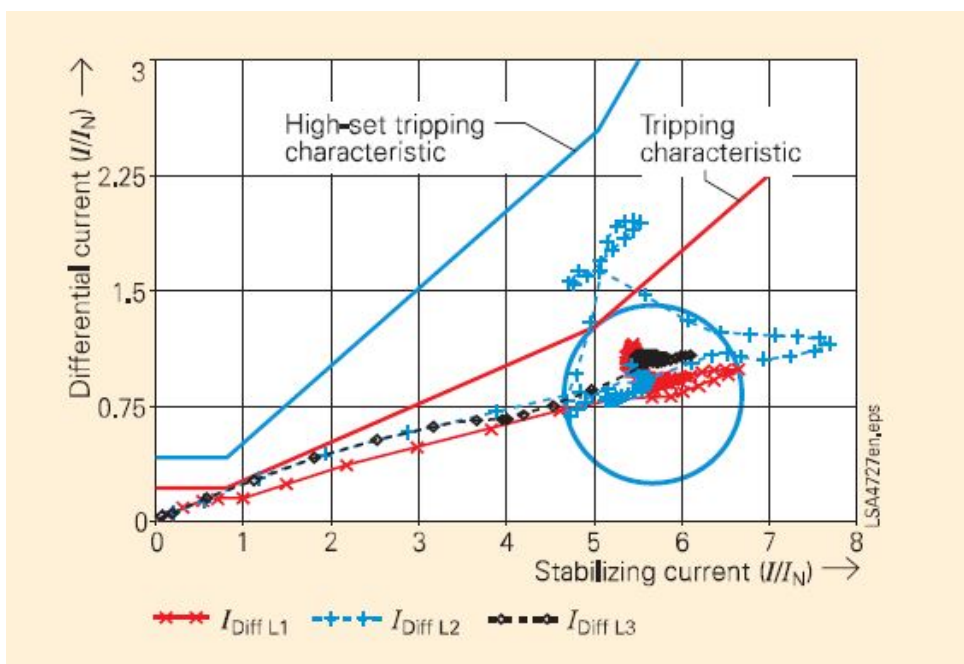

Fig.2: Differential currents during motor starting (approx. 5sec) [2]

The result being that the operating point moves into the tripping zone above the tripping characteristic shown, in the worst case entailing unintentional tripping of the differential protection.

1.4 Differential Protection Versions

The Korndörfer Starter is available in version with and without current transformer in QA3 path.

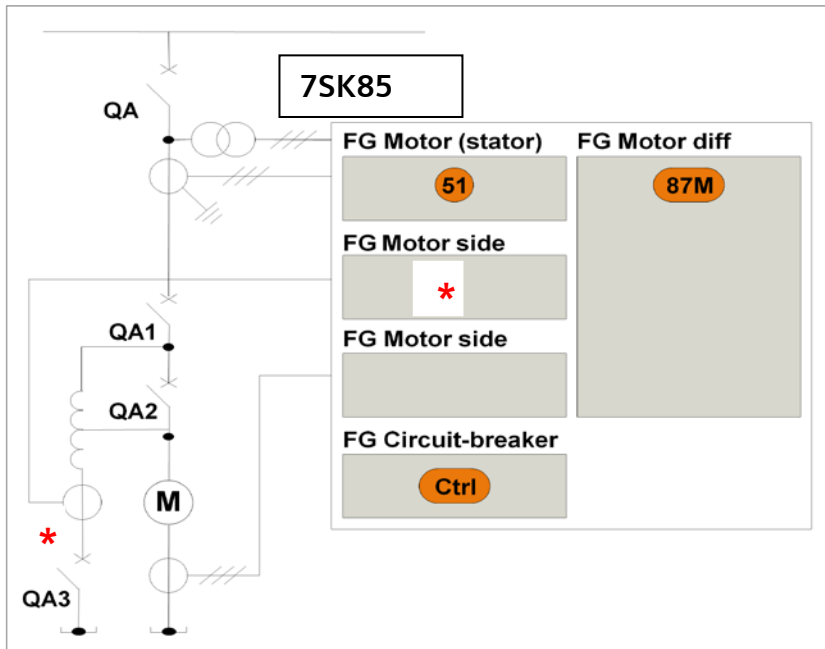

Fig.3: 7SK85 Motor Protection with Korndorfer Starter; (*additional CT, additional Function Group)

That offers different possibilities for a save Differential Protection.

1.4.1 Version without additional CTs

From recordings during commissioning we learned that starting current follows a typical curve. A current peak caused by compensation phenomena during shorting the starting transformer (closure of Q2) is conspicuous.

To avoid over-function in case there is no additional current transformer, the differential protection's pickup value can be increased during starting.

It is recommended to increase the motor differential protection characteristic by a factor of two (2).

Duration of the pickup increase should be maintained beyond this time.

This is possible with parameter set switch over by using related binary input signal to change the setting group in 7SK85. This is described in a separate application paper: (SIP5-APN-023_Change Setting Group via CFC).

1.4.2 Version with additional (3rd) CT in QA3 path

If the full sensitivity is not to be dispensed with, an additional current transformer at the starting transformer's star point (see Fig.3) is needed to extend the differential protection zone.

SIPROTEC 5 Applikation

Protection of Asynchronous Motors with Korndorfer Starter

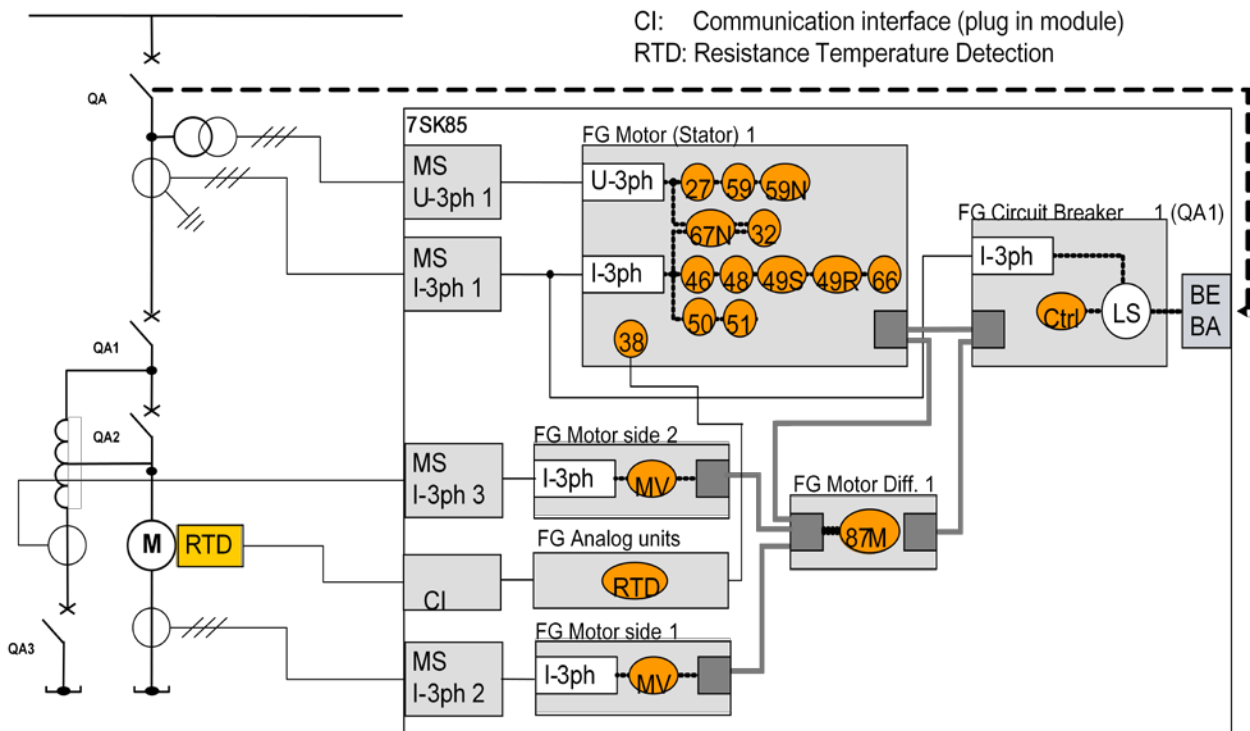

Fig. 4: 7SK85 Motor Differential Protection with additional CT and additional Function Group Motor Side

As a result, the correct measured values are fed to the differential protection, also during starting, and rising of the pickup characteristic can be dropped – the differential protection also operates during starting with normal sensitivity.

With SIPROTEC 7SK85 the flexible extension of necessary Measuring Input with IO module is very easy. In this case it is recommended to select the dedicated device with use of SIPROTEC 5 Online Configurator.

- > SICAM RTU Substation Automation / Telecontrol
- ▼ Protection SIPROTEC 5
 - > SIPROTEC 5 Configurator - Perfectly tailored fit

SIPROTEC 5 Configurator - Perfectly tailored fit

- > Base functionality
- > Modules
- > Plug-in modules/Communication
- > Housing
- > Sales options

Device: 7SK85 Motor Protection

Product code
Short: P1H16773
Long: 7SK85-DAAA-AA0-0AAAA0-AX0111-12112A-CAA000-000AA0-CB1BA1-CC1

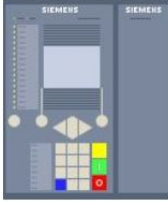

Housing width: 3/6 x 19"
 Housing type: Flush mounting
 Binary inputs: 15
 Binary outputs: 13 Relays (3 Standard, 10 Fast, 0 High-Speed, 0 Power)
 Current transformers: 12 for protection, 0 for measurement and sensitive ground-current detection
 Voltage transformers: 4
 Modules in 19" row 1: IO202, PS201, IO203
 Modules in 19" row 2:
 Number of LEDs: 16
 Operation Panel: Integrated
 Key switch: Without

Save result as PDF

Finish configuration

← Previous

Fig. 5: 7SK85 Selection example

Thanks to the modularity of SIPROTEC 5 platform it is possible to tailor the hardware to the needs.

In above example (Fig. 5) the basic device 7SK85, consisting of Power Supply module PS201 and IO-module IO202, is extended by an additional IO-module IO203.

That results in a device with 3 x 4 current measuring inputs, 4 voltage measuring inputs and several binary inputs and outputs.

This quantity structure fits to the single line diagram in Fig. 4.

Functional adaption is done by inserting and activation of a Measuring Point for the additional CT (MS I-3ph 3) as well as a Function Group Motor Side (2) and the connection of this FG with the Function Group FG Motor Diff.1.

This will be easily done in the step: Functional Group Connection of the Configuration and Operation Software DIGSI 5 (see Fig. 6).

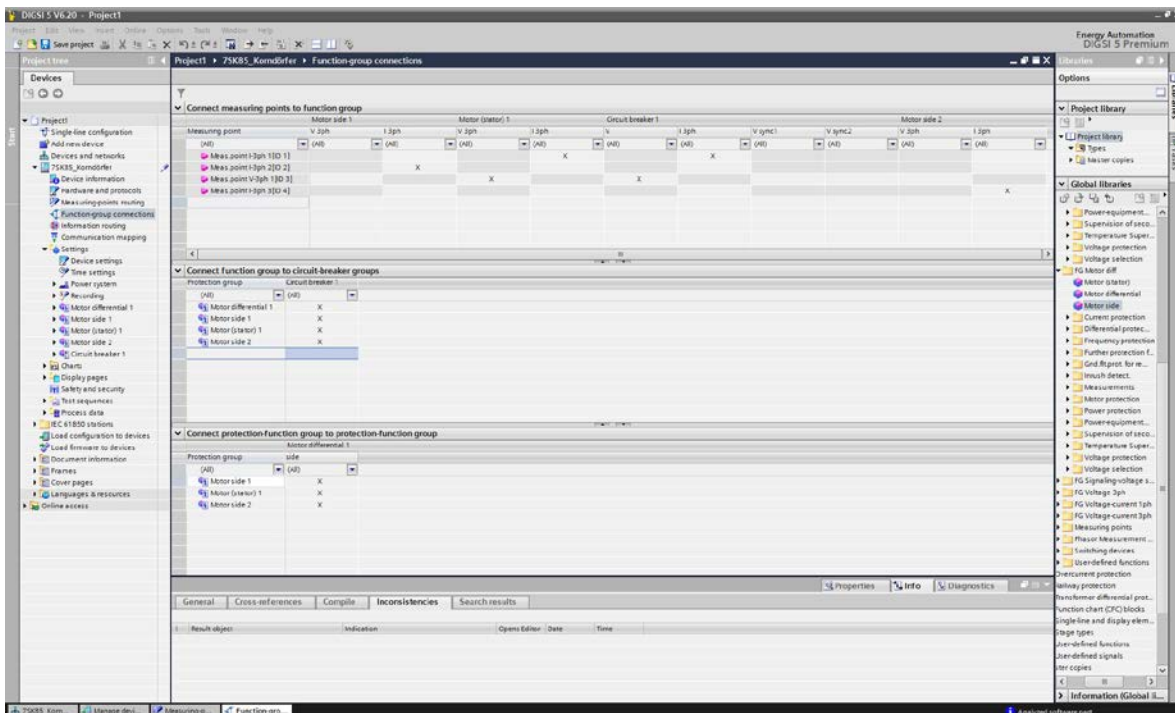

Fig. 6: 7SK85 – Function Group Connection in DIGSI 5

1.5 Conclusion

By using motor protection SIPROTEC 7SK85 – a device of the modular SIPROTEC 5 series – it is easy to provide necessary protection functionally for any requirement.

Protection of large Asynchron Motors with Korndorfer starter is perfect application for devices of SIPROTEC 5 family.

References:

[1] https://en.wikipedia.org/wiki/Korndorfer_autotransformer_starter

[2] Optimum_Motor_Protection with SIPROTEC Protection Relays; by Dr. Hans Joachim Herrmann, SIEMENS AG, Order Nr: E50001-K4454-A101-A1-7600

Published by
Siemens AG 2016
Energy Management Division
Digital Grid
Automation Products
Humboldtstr. 59
90459 Nuremberg, Germany

www.siemens.com/siprotec

For more information,
please contact our
Customer Support Center.

Tel.: +49 180 524 70 00

Fax: +49 180 524 24 71

(Charges depending on provider)

Email: support.energy@siemens.com

© 2016 Siemens. Subject to changes and errors.
The information given in this document only contains
general descriptions and/or performance features which
may not always specifically reflect those described, or
which may undergo modification in the course of further
development of the products. The requested performance
features are binding only when they are expressly agreed
upon in the concluded contract.

For all products using security features of OpenSSL, the
following shall apply:
This product includes software developed by the OpenSSL
Project for use in the OpenSSL Toolkit.
(<http://www.openssl.org/>)
This product includes cryptographic software written by
Eric Young (eay@cryptsoft.com)
This product includes software written by Tim Hudson
(tjh@cryptsoft.com)
This product includes software developed by Bodo Moeller.