

Installation Instructions

⚠ DANGER

Hazardous voltage.
Will cause death or
severe injury.

Turn power off supplying
device before installing.

SAFETY INSTRUCTIONS

NOTE: These instructions outline the recommended installation procedure. The term circuit breaker used in these instructions also includes molded case switches, and motor circuit interrupters.

1. **Turn power off** supplying device before installing kit.

MOUNTING PREPARATION (Fig. 1)

2. Drilling locations are shown Fig. 1. The 5/8" wide cutout between holes is required when mounting the breaker with stud assemblies to a metallic panel.

BREAKER PREPARATION (Fig. 2)

3. Remove terminal covers from line and load ends of breaker and remove wire connectors from breaker if present.
4. Attach rear stud assemblies (1 & 2) to circuit breaker for 3 pole devices (item 1 only for 2 pole devices). Attach with 3/8-16 x 1 1/4" hex head bolt (3) & the 3/8 serrated cone lockwasher (4). Tighten finger tight only.

GENERAL DESCRIPTION

One complete rear stud assembly consists of the following:

- 1 - 1"-12 threaded stud.
- 1 - Molded stand-off insulator
- 1 - Insulator bushing
- 1 - Insulator (req'd for metallic mtg. panels only)
- 1 - "T" connector
- 2 - Brass locknuts
- 1 - 3/8-16 x 1 1/4 mtg. bolt
- 1 - 3/8 serrated cone lockwasher

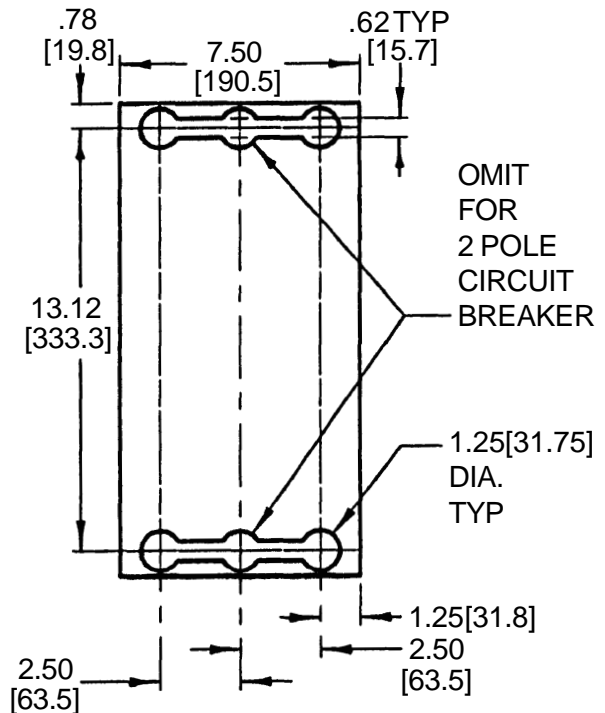

Fig. 1

CIRCUIT BREAKER TYPE	AMPS	POLES	QUANTITY REQUIRED PER BREAKER
LMD6, HLMD6, LMXD6 LMFC, LMFF	800	2	4 ea. Cat. No. RS5787
		3	4 ea. Cat. No. RS5787 and 2 ea. Cat. No. RS5788



Installation Instructions

BREAKER PREPARATION CONTINUED (Fig. 2)

- Slide one stand-off insulator (5) onto each stud until the stand-off insulator fully covers the square end of the studs. Tighten bolt (3) to 150 In.-Lbs. [16.9 N/m]. Note: If using a metallic mounting panel, install insulator (10) over studs.

FINAL ASSEMBLY (Fig. 3)

- Install circuit breaker so that all studs extend through mounting panel and the stand-off insulators (5) are seated against the mounting panel.
- Install insulator bushings (6 & 7) onto studs as shown and tighten them securely against the mounting panel using locknut (8).
- Thread the second locknut (8) and the "T" connector (9) over the studs as far as possible. Position "T" connector as desired by loosening (1 full turn max) and lock in place with the second locknut (2). Tighten locknut to 132 In.-Lbs. [14.9 N/m].

IMPORTANT USER NOTE

Assemblies are designed with adequate 600 volt electrical clearance between components. User must maintain these clearances through spacing or proper insulation.

- Insert the end shields (11) into the slots provided at the line & load ends of the terminal covers as shown in Fig. 2, one for each stud position. Replace terminal covers and shields.
- Affix the label "BREAKER IS EQUIPPED WITH REAR CONNECTING STUDS" (12) Pc. No. 60229 to breaker cover as shown in Fig. 2.
- Make desired bus bar connections using 5/16 bolts & washers to "T" connectors. (See Fig. 3 for hole pattern of "T" connector).

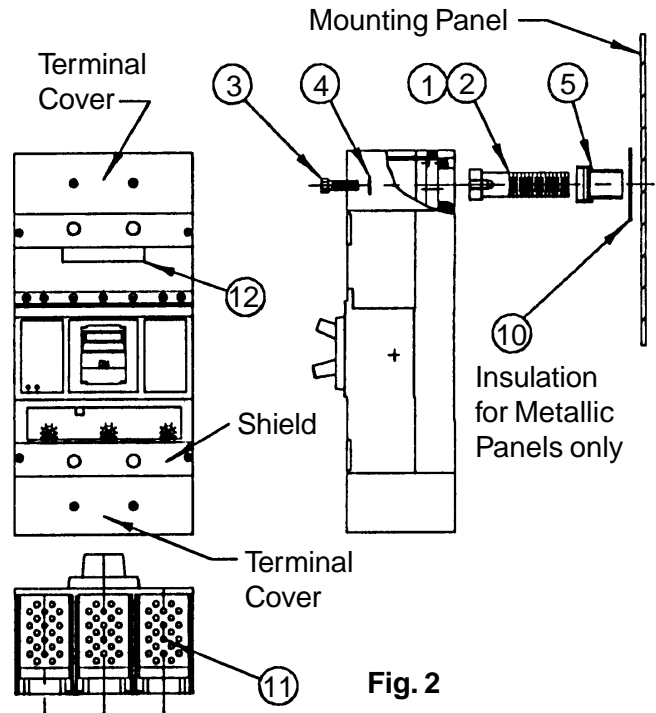

Fig. 2

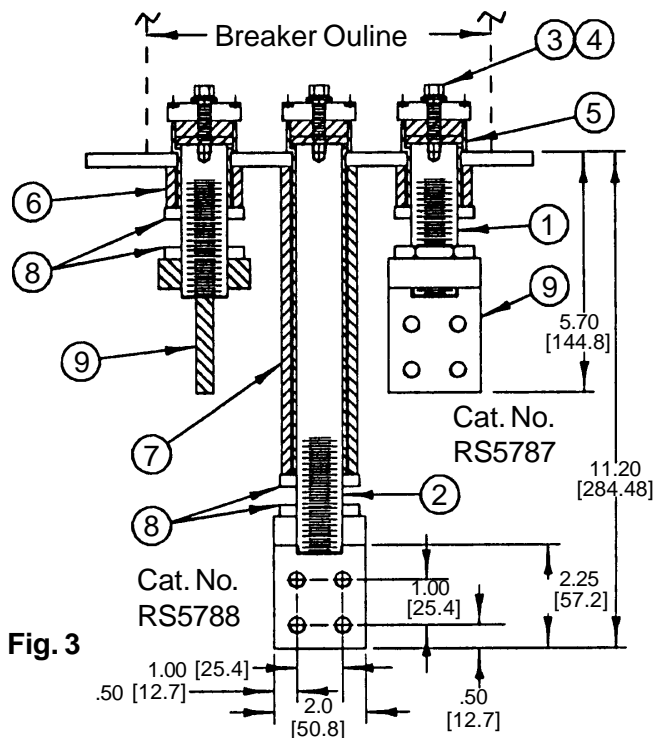

Fig. 3