

Catalog Numbers, Ratings and Features

Catalog No.	Max. Branch Rating	Main Bus, 1200A Max.	Breaker Type	Meter Socket Cover	Meter Socket Type/ Continuous Rating	No. of Jaws	Bypass Type	Neutral Lug (Qty) and Wire Range	Equip Ground Lug (Qty) and Wire Range
WML22CA225RJ	225A	3 Phase	2 Pole QS	Ringless	HQ-5S / 200A	5	Lever	(2) #4-300 kcmil	(3) #4-2/0 AWG

- TYPE 3R OUTDOOR ENCLOSURE
- 208Y/120 VOLTS AC, 3 PHASE, 4 WIRE
- STACK PHASING: AB, CB
- 3 PHASE INPUT, 1 PHASE OUTPUT
- MOUNTING RAILS AND ADJUSTABLE BRACKETS FOR SECURE MOUNTING

Additional Modules and Accessories

FOR USE WITH:	Siemens Series#	Murray Series#
Main Breakers	(W)MC, WB, WEB	DB W
Switches	WMP, WMS, WS, WES	DPT W, DT W
Tap/Terminal Boxes	WMTB, WTB, WET	DTB_W
Meter Module	WMM, WxMM, WMT, WML, WMK	DG_W, DC_W, DL_W
Extension Box	WMEX, WSP	DS
Bussed Elbow	(W)BE	DL

Connect Modules Using:	Catalog Number / Torque
QuickConnect	QC1 (1ph) or QC4 (3ph) 400-440 lb-in (35-36 ft.-lb.) Torque
Single Bolt Joint	SBJ1 (1ph) or SBJ4 (3ph) 400-480 lb-in (35-40 ft.-lb.) Torque

Schematic

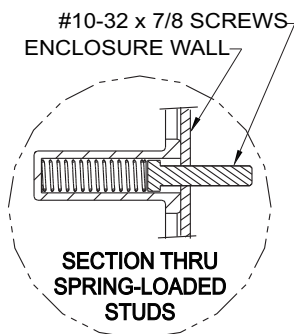
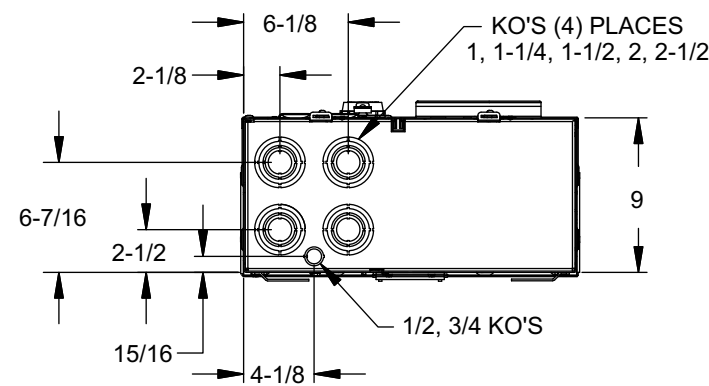
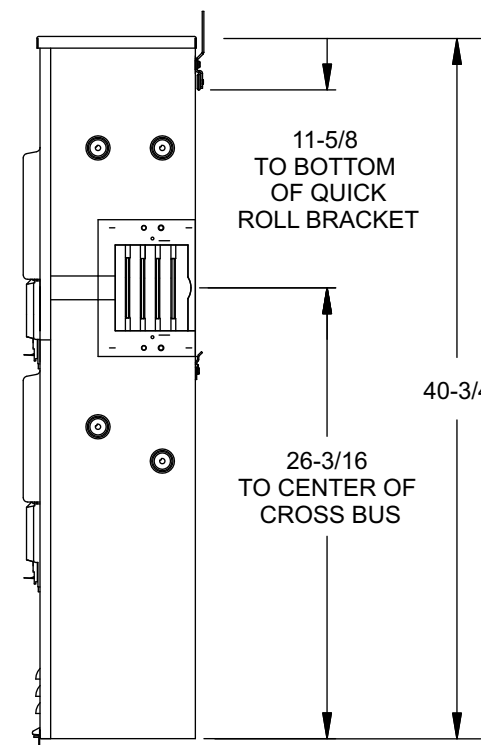
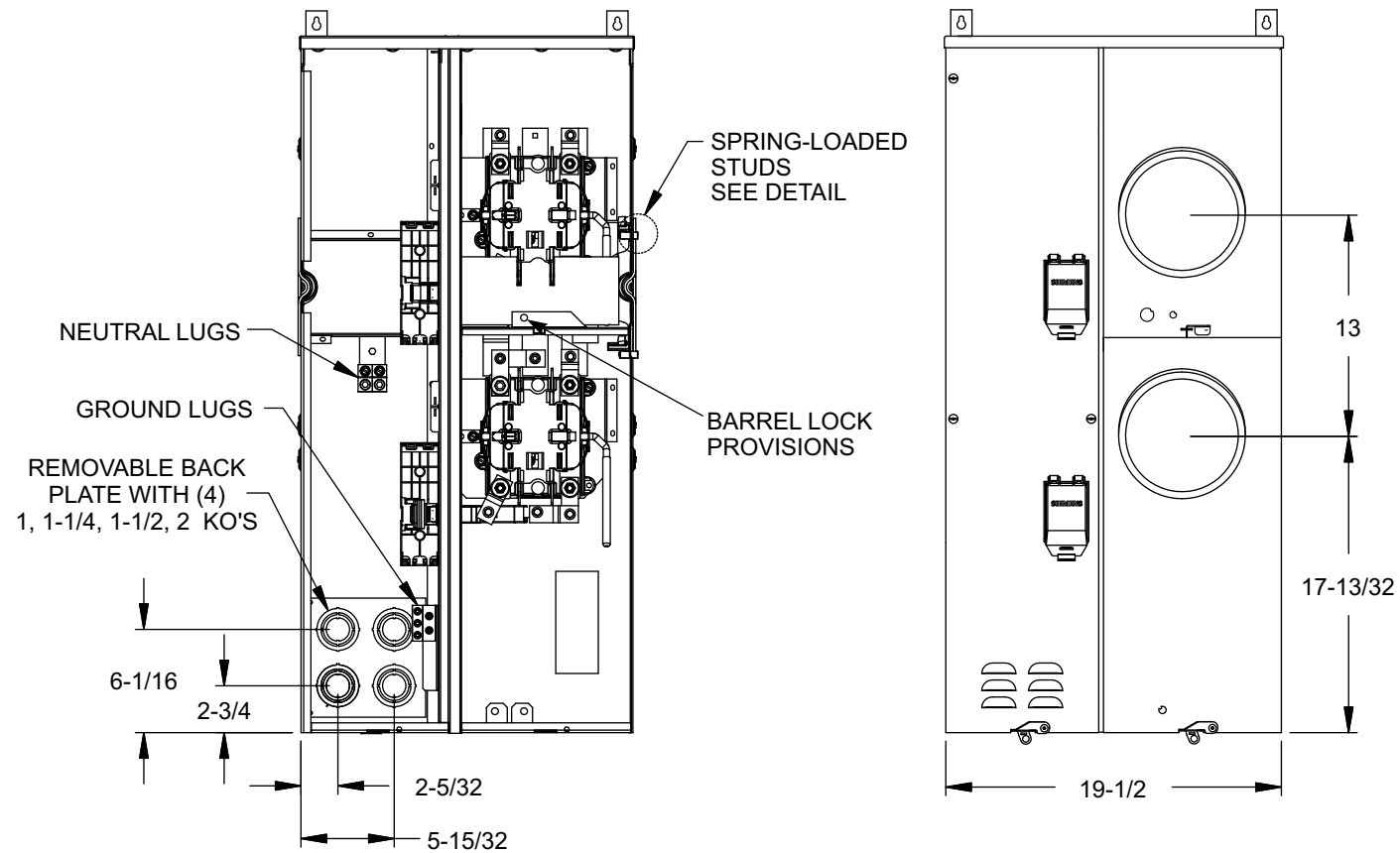
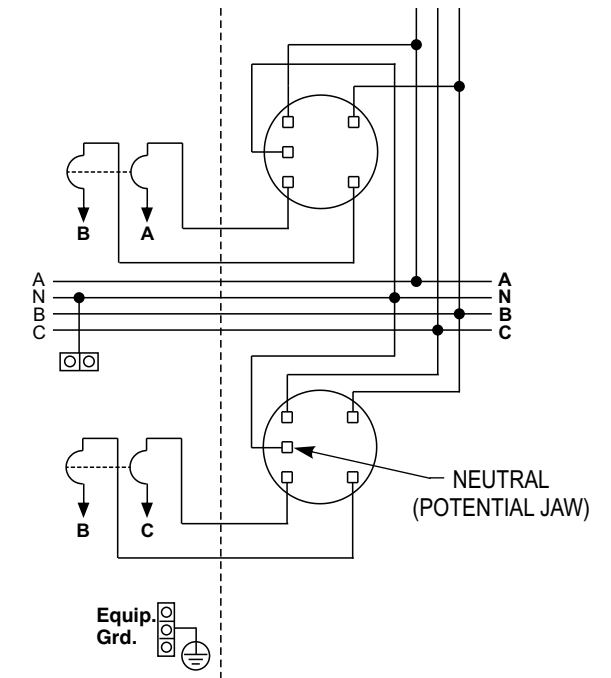

Enlarged Socket Detail

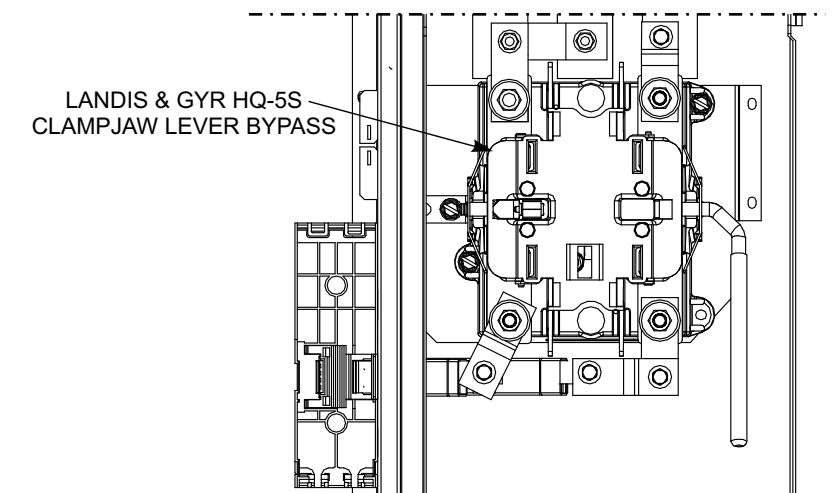

© 2010 Copyright Siemens Industry, Inc.

Siemens Industry, Inc.
Building Technologies Division

PowerMod™ Modular Metering

Description: **Lever Bypass 2 Position 225A Tenant 3in-1out Commercial Metering Module**

Size B Dwg. No. **WML22CA225RJ**

Dwn KAM Date 1/27/10 DO NOT SCALE DRAWING SHEET 1 OF 1