

NOTES

- TERMINALS RECOMMENDED ARE PRE INSULATED & MUST BE CRIMPED USING APPROVED TOOLING. AMP PIDG OR PLASTI GRIP FUNNEL ENTRY (RING TONGUE) FOR M4 FIXING STUD.

SUPPLIER	AMP	CABLE SIZE
AMP	342103	0.25-1.6 SQ MM
AMP	342143	1.0-2.6 SQ MM.

OR ANY OTHER MANUFACTURERS EQUIVALENT TERMINAL.

- FOR OUTLINE & DRILLING DRG SEE 2995X10016 (A4).
- IRIG-B & FIBRE OPTIC CONNECTORS MUST BE DISCONNECTED & FIXING NUTS REMOVED BEFORE WITHDRAWING CONTROLLER MODULE.

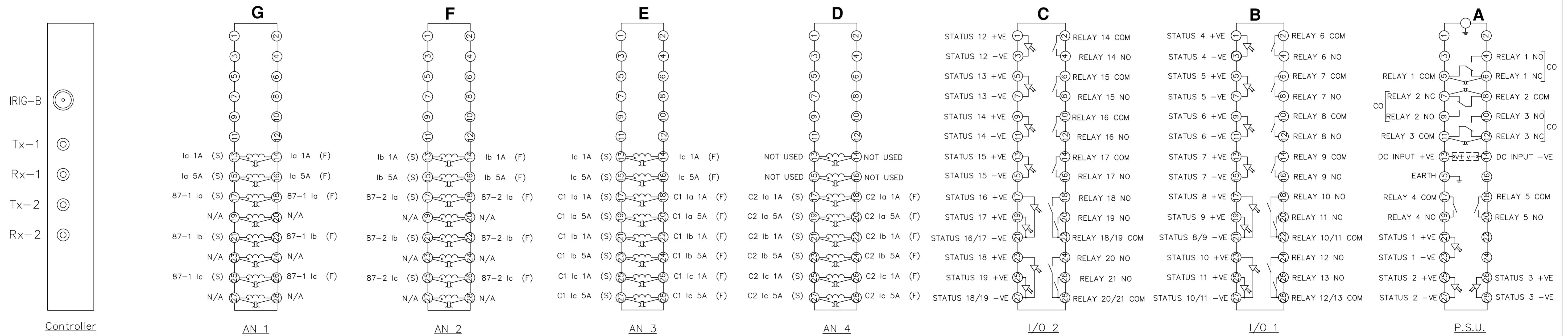

Controller Module  
(SEE NOTE 3)

MODULE LABEL KEY	
ANALOGUE MODULE	AN 1 etc
INPUT/OUTPUT MODULE	I/O 1 etc
P.S.U. & BASIC I/O MODULE	P.S.U.

ABBREVIATIONS	
CT	CURRENT INPUTS
VT	VOLTAGE INPUTS
SI	STATUS INPUTS
CO	CHANGE OVER OUTPUT CONTACTS
NO	NORMALLY OPEN OUTPUT CONTACTS
NC	NORMALLY CLOSED OUTPUT CONTACTS

MATERIAL:

Dimensions in millimetres : Surface texture in micrometres.  
Machine where marked ✓  
For explanation of dimensions, tolerances, notes etc. see B.S.308.  
Limit on untoleranced unmachined dimensions ±  
Limits on untoleranced machined dimensions to B.S.4500;  
i.e. up to 6±0.1; over 30 to 120±0.3; over 315±0.8;  
over 6 to 30±0.2; over 120 to 315±0.5;  
General unmachined angular tolerance ±

Finish: \_\_\_\_\_ Title: \_\_\_\_\_  
Treatment: \_\_\_\_\_ TERM IDENT & WIRING DIAGRAM FOR MSCDN-MP1  
(15CT,19SI,3CO,18NO) E16 CASE  
**VA TECH Reyrolle**  
**AUTOMATION, CONTROL & PROTECTION**

Original Scale: \_\_\_\_\_ Drg. No. **2621W11001**  
Supersedes: \_\_\_\_\_  
First used on: \_\_\_\_\_  
Similar Articles: \_\_\_\_\_  
Supersedes: \_\_\_\_\_

**NOT SUBJECT TO UPDATE  
ONCE COPIED / PRINTED  
OR DOWNLOADED**

Copyright © 2002 VA TECH Reyrolle Ltd. Hebburn