



SERVO ON! MOVE BEYOND.

SINAMICS S200

Servo drive system

www.siemens.com/sinamics-s200

SIEMENS

Servo on! Move **beyond.**

SINAMICS S200 servo drive system

Higher productivity, improved efficiency but at a lower cost – we are always looking to achieve an optimal balance in today's fast-changing market.

This is precisely where the new member of the SINAMICS family comes into its own: The SINAMICS S200 servo drive system.

The system fully complies with the requirements of standard applications with optimized performance and ease of use. It provides a cost-efficient solution that delivers the optimal balance of price and performance. Further, in conjunction with a digitalization concept, the hardware and software are perfectly harmonized to equip customers for the future.

Discover right now what it can do and let it drive your business beyond your expectations.



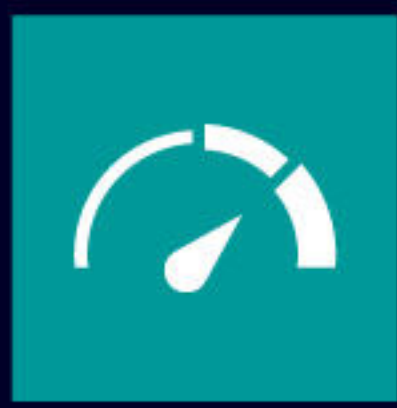

Performance
optimized

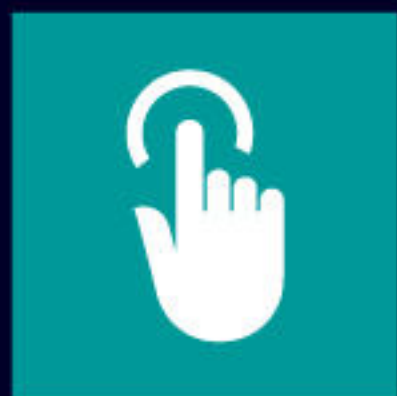

Easy to use



Fit for future

The system comprises a SINAMICS S200 servo drive, a SIMOTICS S-1FL2 servo motor and Motion Connect cables. With a power range extending from 0.1kW up to 7kW and various communication options such as PROFINET IRT and pulse train, the system has been specifically designed to address a wide range of standard applications.





Optimized performance

Addressing the requirements of standard applications

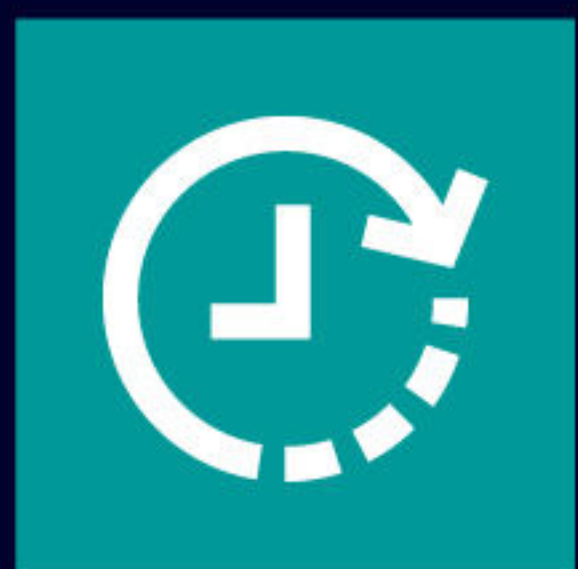

Optimized response

High dynamic response using a fast current controller 125 μ s (PN)

Precise communication with controllers using Profinet IRT* (min. 250 μ s)

* Isochronous Real-Time





Optimized power

With an overload capacity of up to 350%, it can easily master high torque peaks, which helps you and your customers increase productivity.

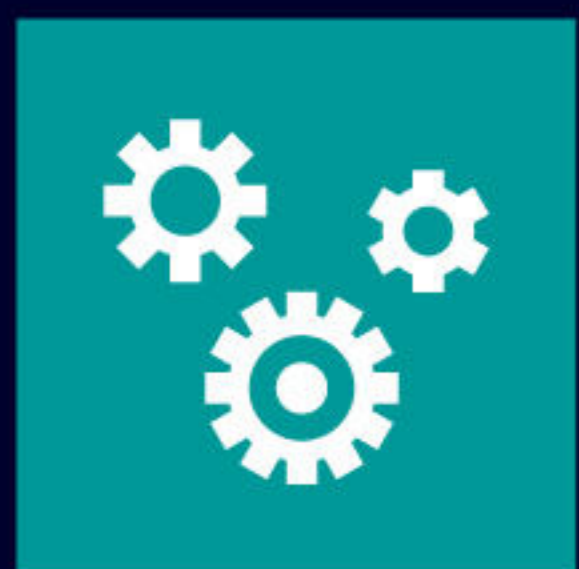
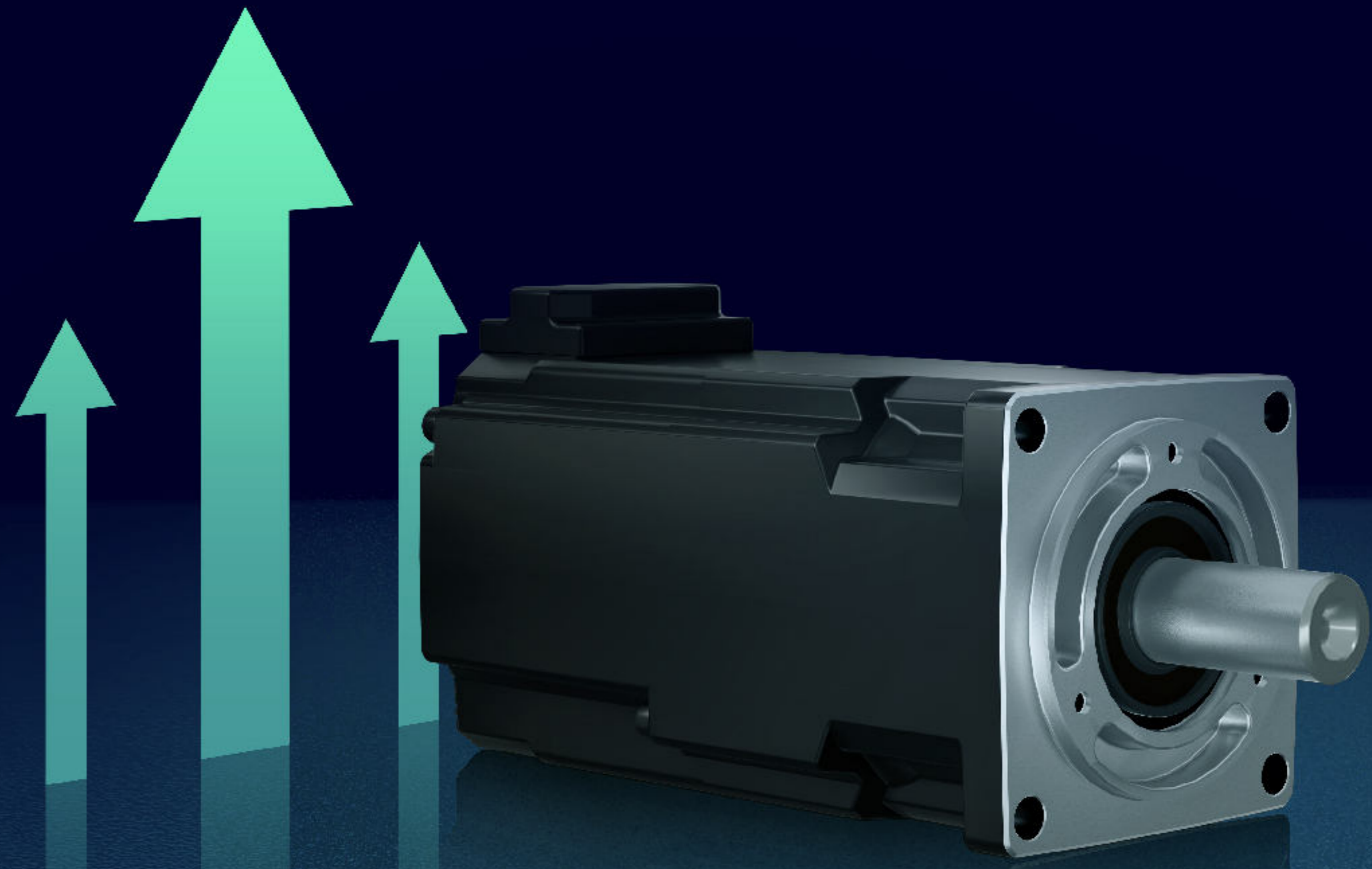

Optimized precision

Equipped with a high-resolution encoder with up to 21 bits, it responds to extremely small speed or position deviations, ensuring smoother and more precise control in challenging applications. Together with a no-battery design, it helps you reduce maintenance costs.

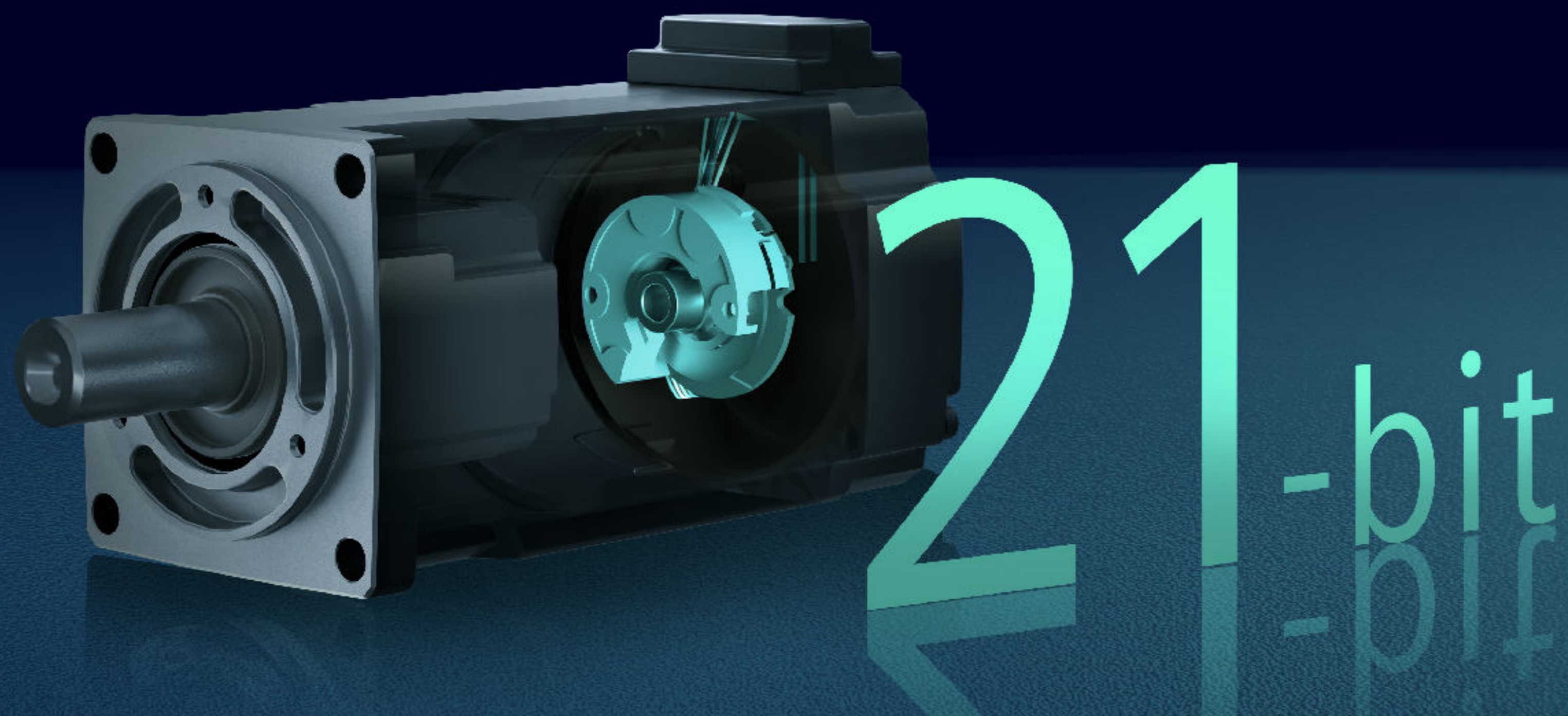



Easy to use



Reduced space requirement



- 1** Width reduced down to 40mm
- 2** Space between devices now down to 1mm

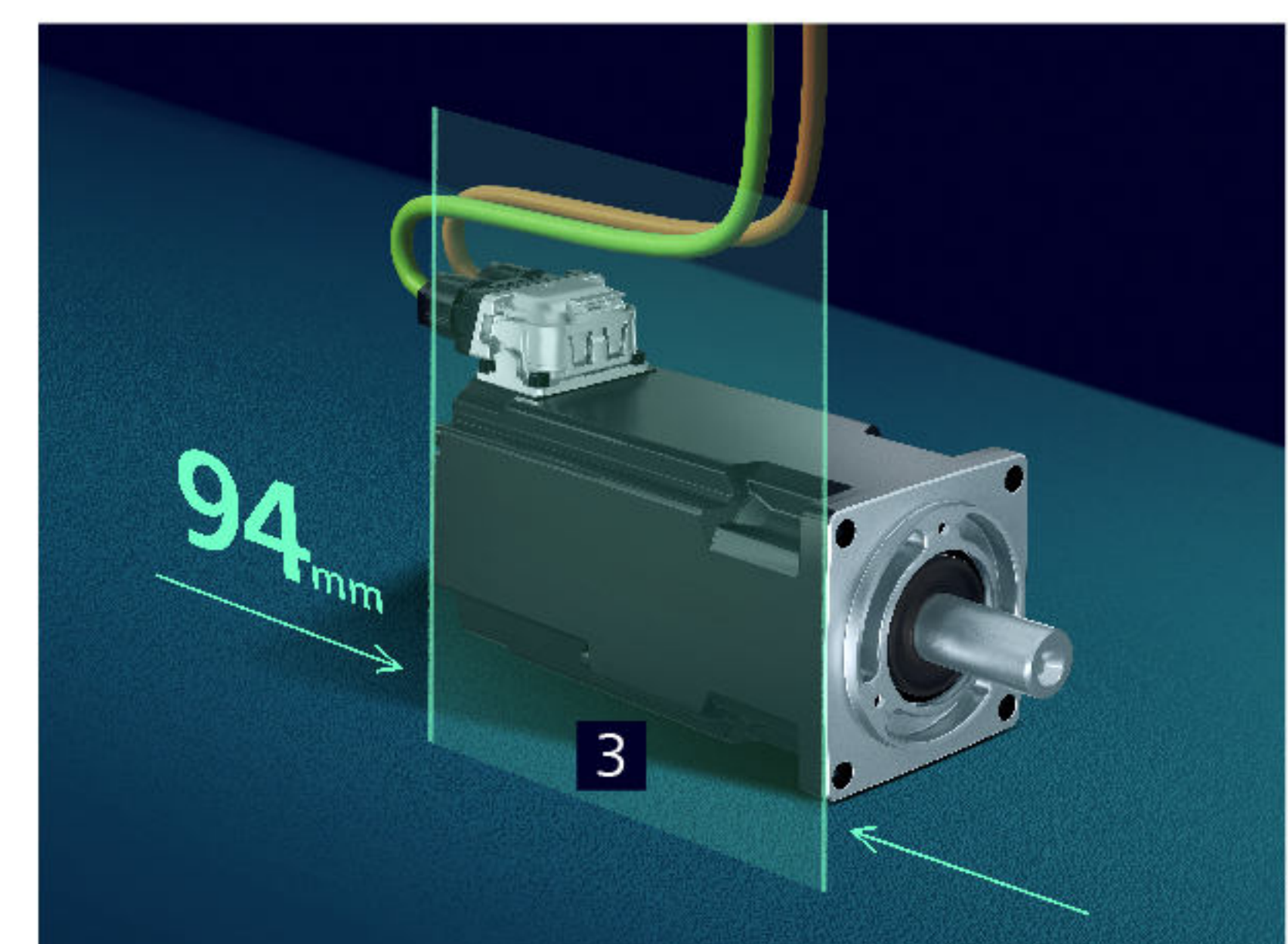

- 3** Length reduced to a mere 94mm*

As a compact system solution, it reduces the overall space required – and the innovative hybrid cabling provides you with a high degree of flexibility when it comes to designing and laying out your machines.

* For the shaft height 30 mm, 400W servomotor



Reduced costs and more convenience



Easy selection

- The **TIA Selection Tool** allows you to configure the mechanical system of your application step by step with no expertise required.
- **Siemens Product Configurator** allows you to quickly select the optimum servo drive device, servo motor or system based on an intuitive user-oriented concept.
- **The SINAMICS Selector App** is a smart mobile app that allows you to quickly and easily select the servo drive that precisely addresses your application.



Easy handling

- **The integrated holding brake control and braking resistor** increases the degree of safety and reduces maintenance costs.
- **Paperless documentation** means that you can easily access the product information required by quickly and conveniently scanning the QR code® on the product.



Easy engineering

- **Startdrive and the integrated web server** make it an efficient and digital engineering experience.
- **One button tuning** streamlines the tuning process and makes it easy to improve performance.
- **The electronic type plate** simplifies the setup process by automatically configuring the servo drive and servo motor as system.



Easy implementation

- The system complies with global safety and performance standards, including CE, UL, UKCA, KC, EAC, RCM, and SEMI47 certifications, which makes it easy to seamlessly integrate these servo drives into your existing systems anywhere in the world.



Fit for future

Flexible system solutions

You can seamlessly integrate the servo drive into your system thanks to the various communication types available, such as PROFINET IRT and pulse train.

- **SINAMICS S200 servo drive**
- **SINAMICS S200 Basic servo drive**

Experience high precision servo motors, equipped with flexible encoder options to address your specific needs.

- **Low inertia** servo motors
- **Medium inertia** servo motors
- **High inertia** servo motors

Enjoy easy and safe installation using flexible cable options – optimized to provide simple and reliable connectivity.

- **Standard** cables
- **Flexible** cables

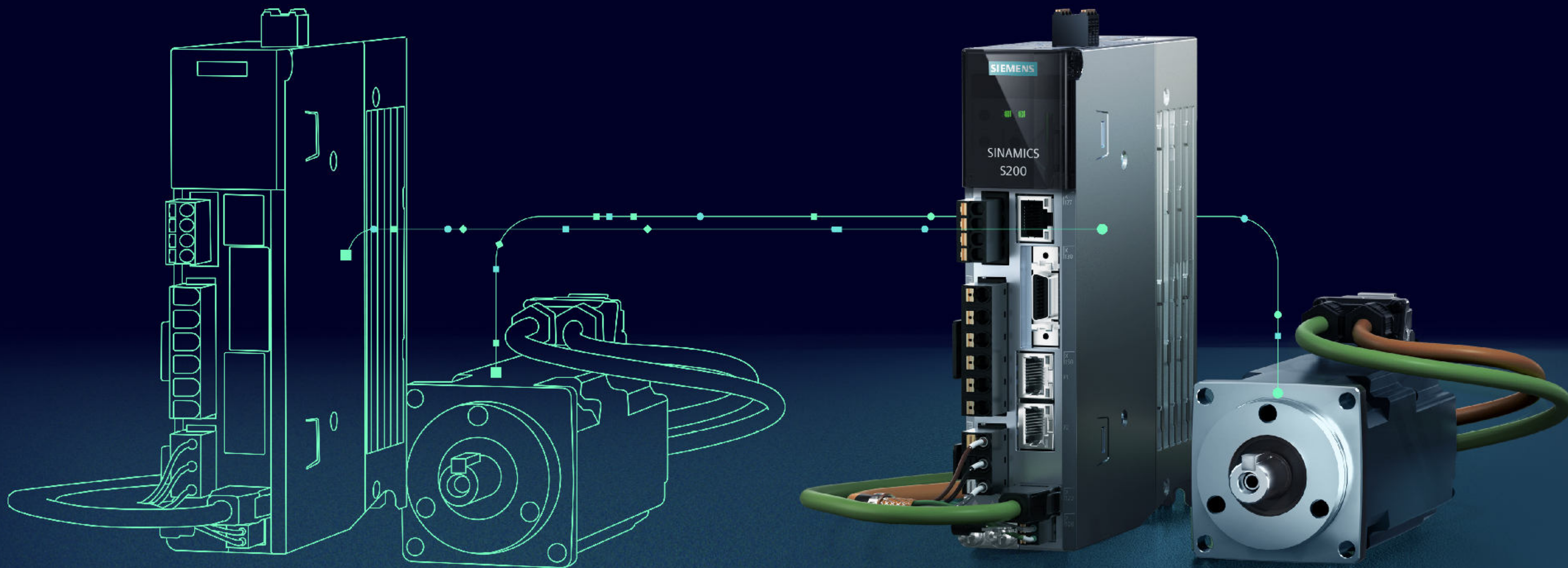

Digital engineering workflow

Together with the digitalization concept, hardware and software are optimally coordinated to help you become fit for the future.

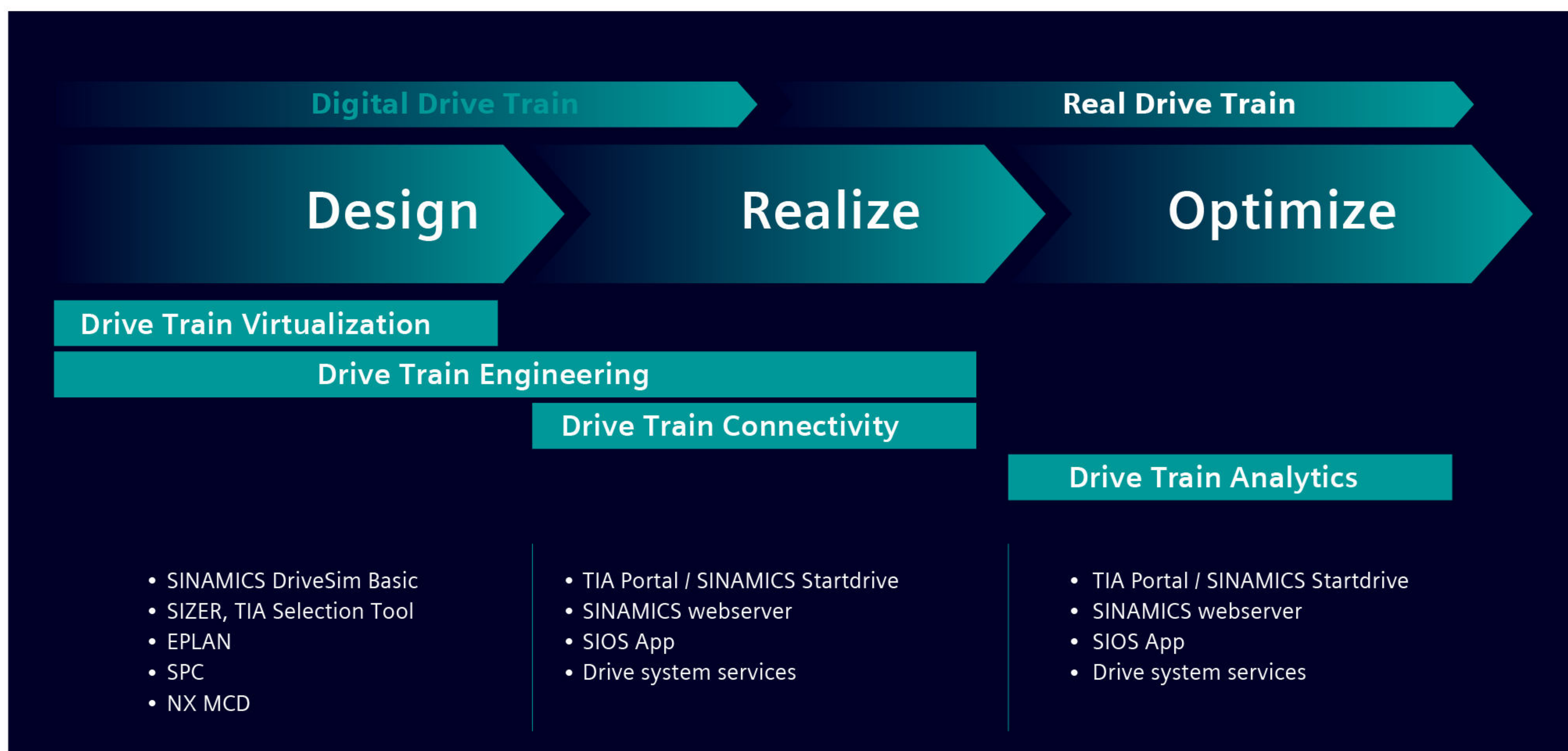

Select your ideal system step by step

Step 1



Dynamic servo motor

SIMOTICS S-1FL2 with high dynamic performance

Article number

1	F	L	2	X	X	X	-	X	X	X	X	X	X	X	X	X	
1	2	3	4	5	6	7		8	9	10	11	12		13	14	15	16

- Inertia**
 - 1- Low inertia
 - 2- Medium inertia
 - 3- High inertia
- Shaft height**
 - 02- Shaft height 20
 - 03- Shaft height 30
 - 04- Shaft height 40 / 45
 - 05- Shaft height 48 / 52
 - 06- Shaft height 65
 - 10- Shaft height 90
- Torque**
 - 0- 11.9Nm
 - 1- 3.58Nm
 - 2- 0.16Nm/0.64Nm/1.27Nm/2.39Nm/3.6Nm/4.77Nm/4.78Nm/16.7Nm
 - 4- 0.32Nm/1.27Nm/2.39Nm/3.18Nm/5.5Nm/6.6Nm/7.16Nm/23.9Nm
 - 6- 8.4Nm/33.4Nm
 - 7- 9.5Nm
- Cooling Method**
 - A- Natural Cooling
- Brake**
 - 0- Without
 - 1- With
- Protection degree**
 - 0- IP 54
 - 1- IP 65 with shaft sealing ring
- Rated speed**
 - G- 3000 rpm, 200V
 - C- 2000 rpm, 400V
 - F- 3000 rpm, 400V
- Version**
 - 0- Initiate
- Connection technology**
 - B- Metal angular connector
 - C- Metal single connector
- Encoder**
 - H- Absolute encoder, single turn, 17 bit
 - S- Absolute encoder, single turn, 21 bit
 - M- Absolute encoder multiturn 21 bit + 12 bit
- Mechanics**
 - 0- Plain shaft
 - 1- Shaft with feather key (half key balancing)

Step 2



Optimized servo drive

SINAMICS S200 with optimized performance and options for versatility

Article number

6	S	L	5	X	1	0	-	1	B	X	X	X	X	X	A	X	X
1	2	3	4	5	6	7		8	9	10	11	12		13	14	15	16

- Product version**
 - 5- S200
 - 6- S200 Basic
- Voltage**
 - B- 200V
 - E- 400V
- Power range**
 - 101- 0.1kW
 - 102- 0.2kW
 - 104- 0.4kW
 - 108- 0.75kW
 - 110- 1kW
 - 115- 1.75kW
 - 125- 2.5kW
 - 135- 3.5kW
 - 150- 5kW
 - 170- 7kW
- Communication**
 - A- Pulse train
 - F- PROFINET

Step 3



Matching cables

Motion Connect 350 and 380 for easy connection

Hybrid connector cables: (suitable for SH20/30/40 1FL2 motor)

Article number

6	F	X	3	X	0	2	-	7	X	X	0	1	1	X	X	0	
1	2	3	4	5	6	7		8	9	10	11	12		13	14	15	16

- Cable variant**
 - 5- MC 350 standard cable
 - 8- MC 380 flexible cable
- Cable type**
 - D- With brake
 - C- Without brake
- Outlet direction**
 - D- Drive end outlet
 - N- Non-drive end outlet
- Cable cross-section**
 - 01- 0.75mm²
 - 02- 1.5mm²
 - 12- 2.5mm²
- Cable length**
 - AD- 3m
 - AF- 5m
 - AH- 7m
 - BA- 10m
 - BF- 15m
 - CA- 20m
 - DA- 30m

M17 or M23 connector cables: (suitable for SH48/52/45/65/90 1FL2 motor)

Article number

6	F	X	3	X	0	2	-	X	X	X	X	X	1	X	X	0	
1	2	3	4	5	6	7		8	9	10	11	12		13	14	15	16

- Cable variant**
 - 5- MC 350 standard cable
 - 8- MC 380 flexible cable
- Connector type**
 - 5- Power connector or brake connector
 - 2- Encoder connector
- Cable type**
 - D- With brake
 - C- Without brake
- Cable connector**
 - K- Power cable with M17 connector
 - L- Power cable with M23 connector
- Cable type**
 - BL- Brake cable
 - XB- Encoder cable
- Cable cross-section**
 - 01- Power cable with M23 connector(0.75mm²)
 - 02- Power cable with M23 connector(1.5mm²)
 - 12- Power cable with M23 connector(2.5mm²)
 - 32- Power cable with M17 connector(0.75mm²)
 - 03- Brake cable (0.75mm²)
 - 11/12- Encoder cable (0.25 and 0.38mm²)
- Cable length**
 - AD- 3m
 - AF- 5m
 - AH- 7m
 - BA- 10m
 - BF- 15m
 - CA- 20m
 - DA- 30m

Technical data

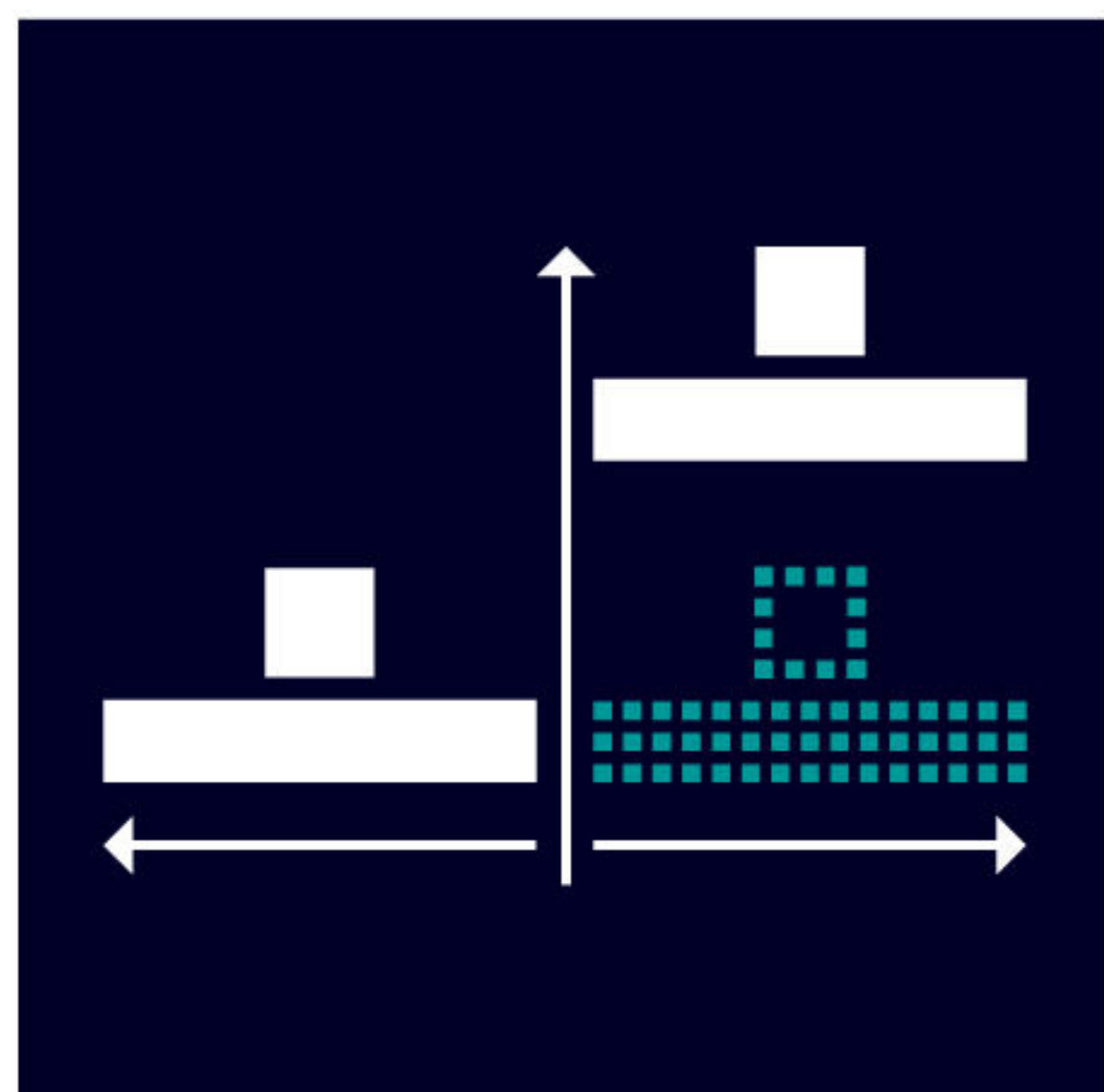

Positioning

The system offers dependable and precise positioning performance for a wide range of applications.

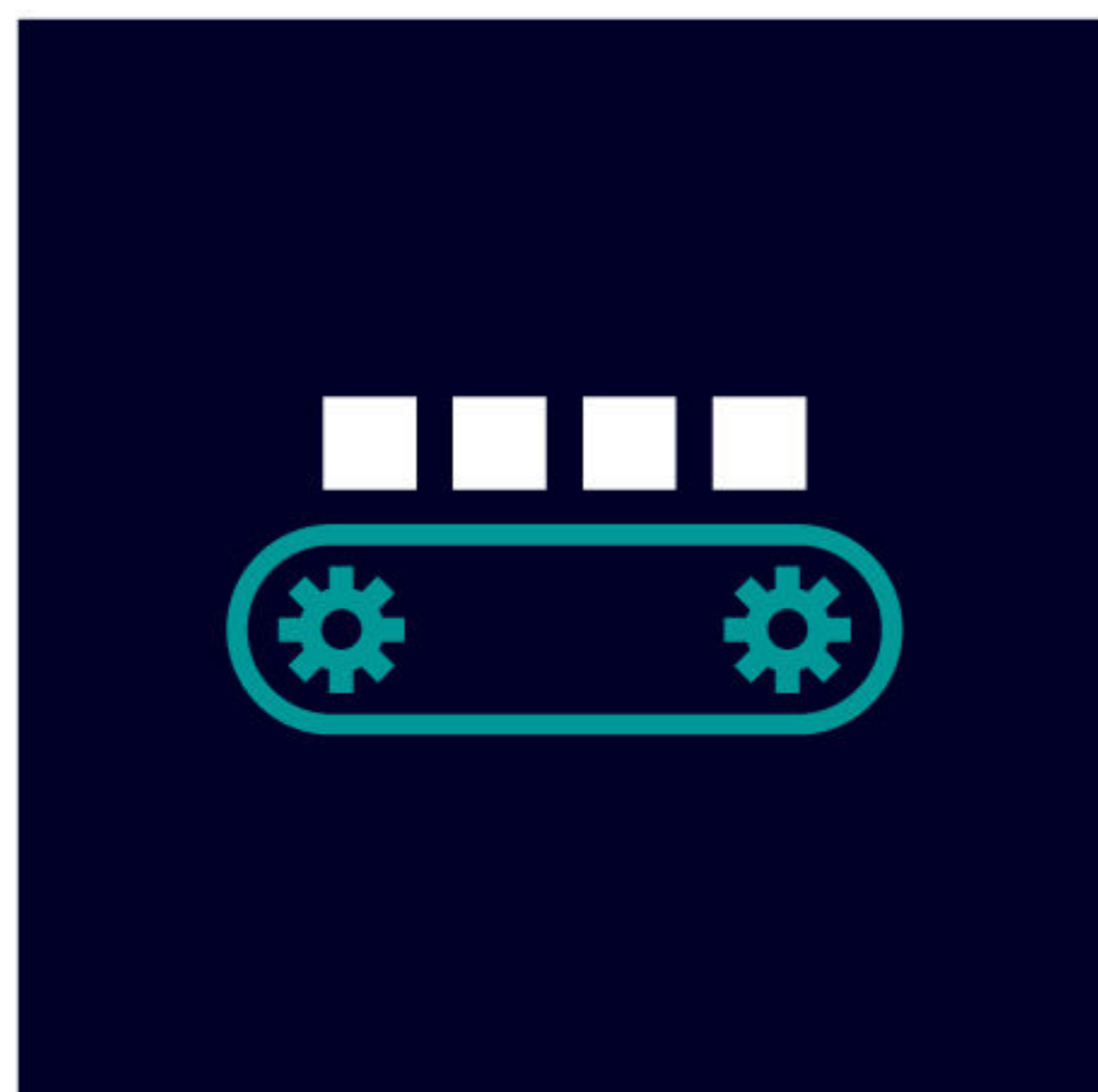

Moving

The system is the ideal solution for both basic and high-speed conveyor systems.

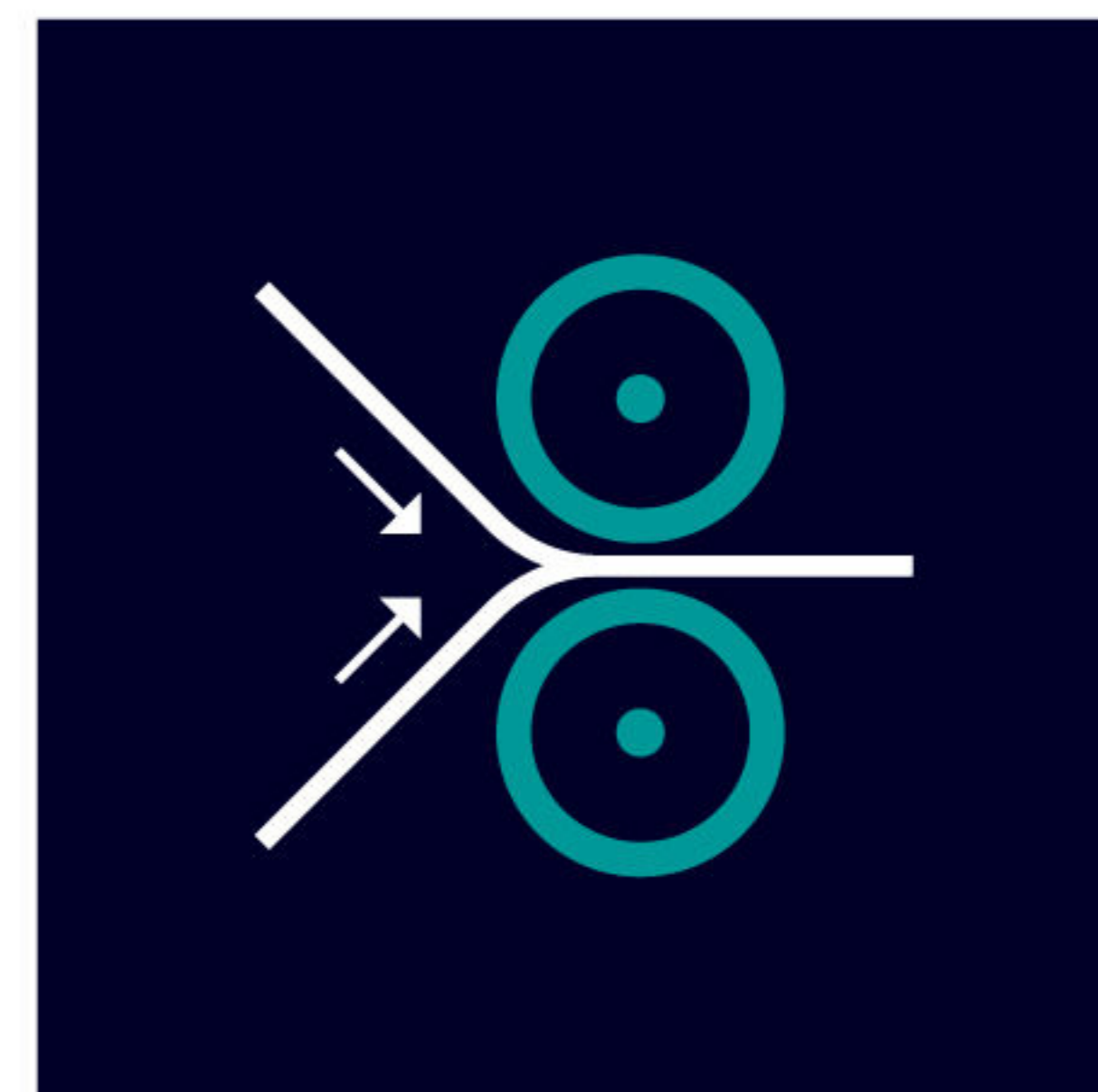

Processing

The system is the ideal choice for processing applications that demand precise speed and torque control.

Technology overview

Features	SINAMICS S200 servo drive system	SINAMICS S200 Basic servo drive system
Power range	1/3 AC 200V 0.1-1kW ; 3AC 400V 0.2-7kW	1/3 AC 200V 0.1-1kW
Current controller cycle	125 µs for PN	125 µs for PN
EMC category	C2 with external line filter	C2 with external line filter
Brake resistor	Integrated brake resistor (>0.1kW)	Integrated brake resistor (>0.4kW)
Holding brake	Direct control of motor holding brake	External relay required for holding brake control
Overload capacity	Max. 350% (up to 0.75kW) ; Max. 300% (up to 7kW)	Max. 350% (up to 0.75kW) ; Max. 300% (up to 1kW)
Safety functions	STO	n.a.
Commissioning / engineering	Web server / Startdrive	Web server / Startdrive
Certifications	CE, UL, UKCA, KC, RCM, EAC, SEMI 47	CE, UL, UKCA, KC, RCM, EAC, SEMI 47
Rotor inertia	SIMOTICS S-1FL21 - Low inertia ; SIMOTICS S-1FL22 - Medium inertia ; SIMOTICS S-1FL23 - High inertia	
Toque range	Mn: 0.16 – 33.4Nm	
Encoder systems	Absolute encoder single turn 17 and 21 bit, Absolute encoder multiturn 21 bit + 12 bit	
Cooling	Natural cooling	
Operating range	-15 to 40 °C without derating and restriction, 40~60 °C with derating	
Degree of protection	IP54, IP65 as option (shaft height 20/30/40) ; IP65 (shaft height 48/52/45/65/90)	
Motor connection technology	One-push-lock connection technology* ^o	
Motor connection options	Length is up to 30 meters without extension cables needed: Standard cable, Flexible cable	
Scalable system	SIMATIC S7-1200, SIMATIC S7-1500/T, ET200SP open controller, SIMOTION	

^o * for low and middle inertia motors only

Application fields

When looking for a system with a high dynamic performance at a favorable cost to help win market share, then the SINAMICS S200 servo drive system is a smart choice. It has been specifically designed to address standard applications in sectors such as batteries, electronics, solar and many other industries.

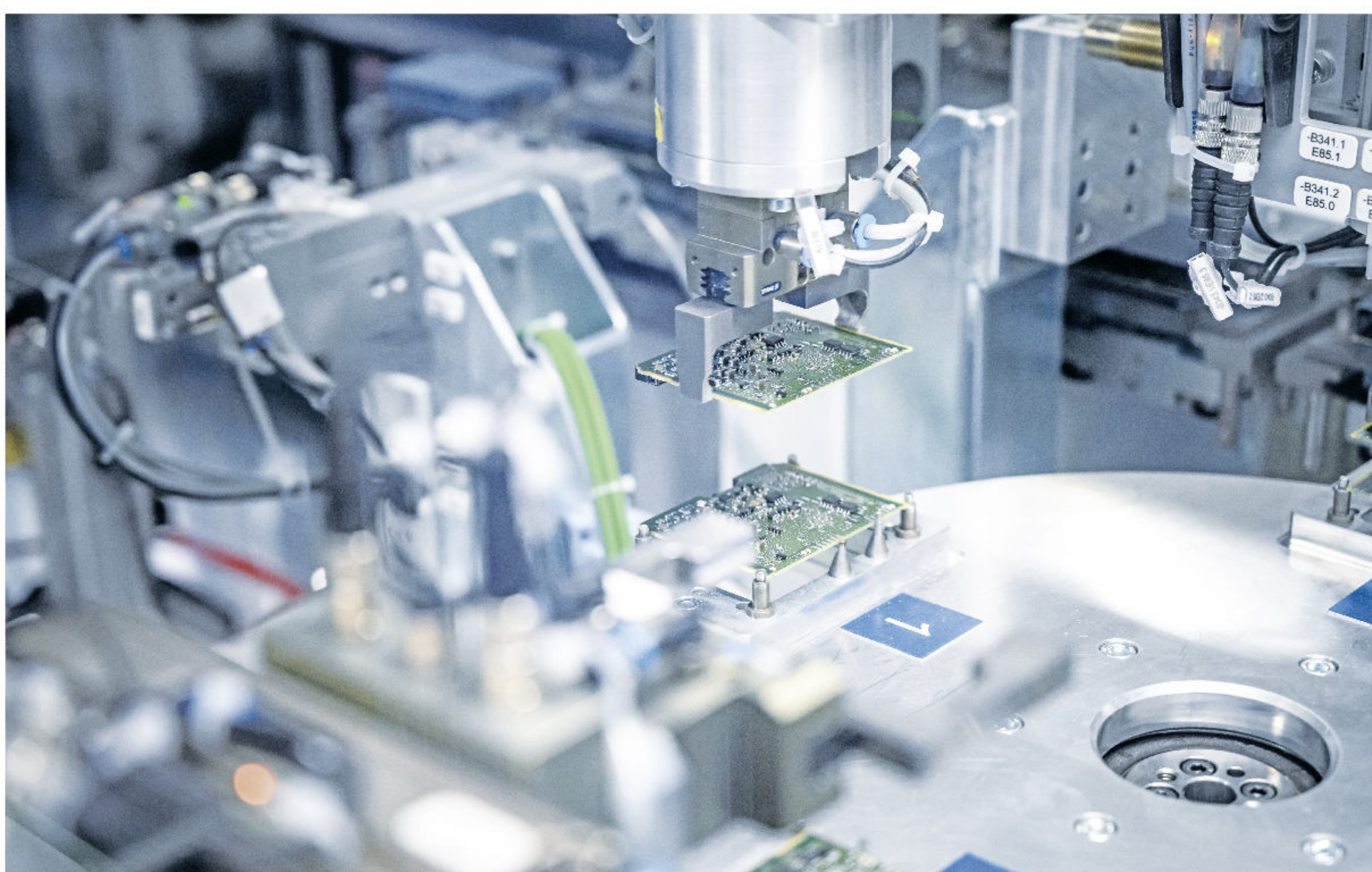
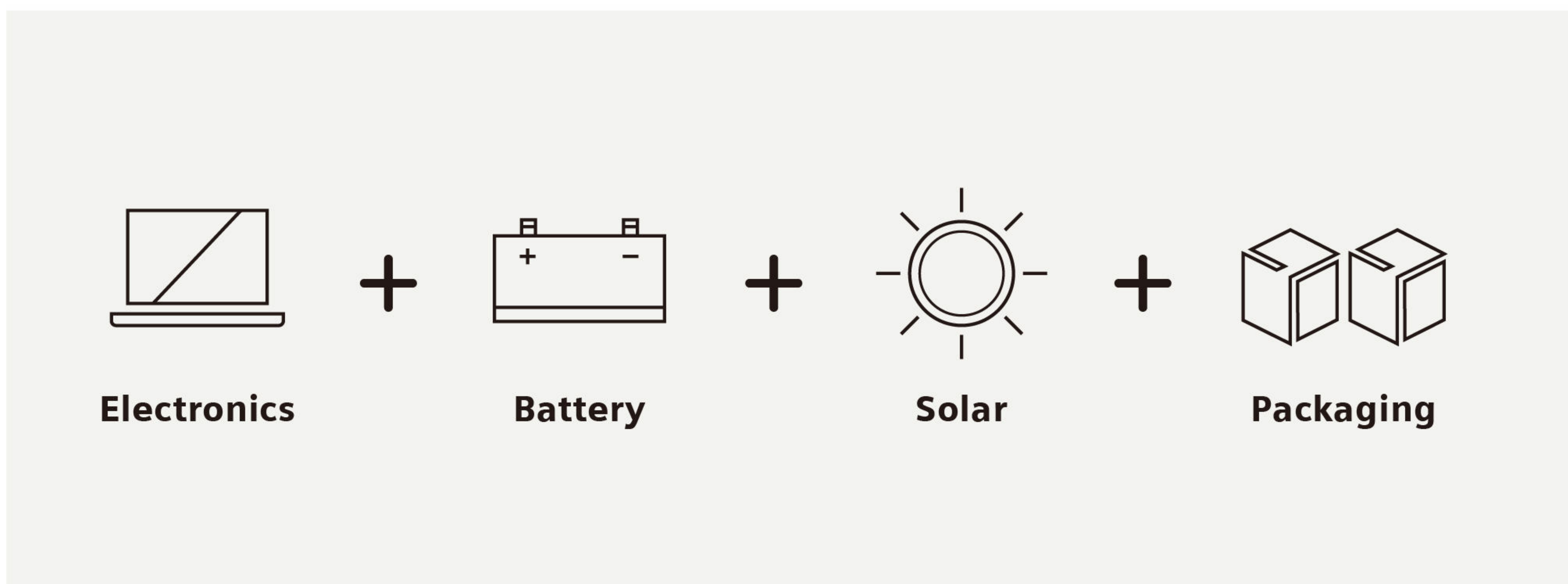

Electronics sector

The SINAMICS S200 servo drive system is a reliable solution that helps increase efficiency and precision in the electronics industry. Its compact design and high dynamic performance makes it an excellent fit for final assembly, testing, packaging and many other processes found in the electronics sector.

- Sorting machines
- Inspection machines
- Gluing machines



Battery sector

The SINAMICS S200 servo drive system is an excellent choice for battery manufacturers who require high dynamic performance, a compact design and certifications for global deployment. With its fast and precise control, the system meets requirements from winding-rewinding, converting and other battery production processes.

- Coating machines
- Stacking machines
- Slitting machines
- Calendering machines



Solar sector

The SINAMICS S200 servo drive system is the perfect fit for the entire solar cell production process, which requires precise positioning, a high degree of productivity and stable operation. The S200 system is easy to commission and is compatible with the TIA Portal – therefore simplifying the implementation of complex automation tasks.

- Ingot production machines
- PECVD machines
- Texturing machines
- Loading and unloading machines



Packaging sector

With its high dynamic performance and fast DI as measuring input, this facilitates high-speed measurements making the SINAMICS S200 servo drive system the ideal solution for the packaging industry allowing machines to be precisely and efficiently controlled.

- Bagger and wrapper machines
- Paper cup machines
- Blister machines
- Labeling machines

Services

Siemens is committed to fully meeting your expectations with its comprehensive service package.

Whether you need onsite or remote services, now or in the future, we are here to provide the support you need to optimize productivity and help you achieve your long-term goals.



Guarantee product use for up to **7.5** years

Empower your business with the S200 servo drive system. Our comprehensive service portfolio covers everything including the drive, motor and cables, ensuring that your systems always perform optimally.

SINAMICS S200 servo drive



SIMOTICS S-1FL2 servo motor



MOTION-CONNECT cables



Register now and take advantage of our premium service package for 6 months.
<https://myregistration.siemens.com>

Contact us

You can easily connect with our experts by accessing 'mySupport' via the Industry Online Support platform.
<https://siemens.com/supportrequest/>

**Published by
Siemens AG**

Digital Industries
Motion Control
P.O. Box 31 80
91050 Erlangen, Germany

For the U.S. published by
Siemens Industry Inc.
100 Technology Drive
Alpharetta, GA 30005
United States

Article No. DIMC-B10111-01-7600
BE/3000070428 WS 1205 PDF
© Siemens 2023

Subject to changes and errors. The information given in this document only contains general descriptions and/or performance features which may not always specifically reflect those described, or which may undergo modification in the course of further development of the products. The requested performance features are binding only when they are expressly agreed upon in the concluded contract.

For the secure operation of Siemens products and solutions, it is necessary to take suitable preventive action (e.g. cell protection concept) and integrate each component into a holistic, state-of-the-art industrial security concept. Third-party products that may be in use should also be considered. For more information about industrial security, <http://www.siemens.com/industrialsecurity>.

Scan for
additional
information

