



November 2005 saw the conclusion of a contract between Siemens and the Chinese Ministry of Railways (MOR) for delivery of 60 high speed trains. The 300 km/h trains will initially be put into service on the Peking–Tianjin line. Plans also exist to operate the trains on the lines from Peking to Shanghai and Guangzhou to Wuhan at some point in the future.

The Velaro® CN is based on the advanced train set technology of the Velaro platform, which is already being used by German Rail (DB AG) and Spanish National Railways (RENFE) and has also been sold to Russian State Railways (RZD).

Compared with conventional trains, train sets provide a far higher number of seats from the same overall length. For instance, an eight-car Velaro CN train set offers space for 601 passengers. The geometry of the car body and the layout of the interior furnishings have been specifically coordinated with one another in order to unite good ride quality and a high level of passenger comfort with high seating capacities. The train has two classes in which the passengers are able to enjoy the benefits of a catering service. Apart from that, the passengers can enjoy snacks and beverages in a bistro. An audio and video entertainment system offers 1st class passengers a sophisticated standard of entertainment.

Technical Data

Maximum operating speed	300 km/h (186 mph)
Length of train	200 m
Length of end car body	25,535 mm
Length of intermediate car body	24,175 mm
Distance between bogie centers	17,375 mm
Width of cars	3,265 mm
Height of cars	3,890 mm
Track gauge	1,435 mm
Empty weight	447 t
Voltage	25 kV / 50 Hz
Tractive effort	8,800 kW
Gear ratio	2.79
Starting tractive effort	300 kN
Brake systems	Regenerative, pneumatic
Number of axles	32 (16 driven)
Wheel arrangement	Bo'Bo'+2'2'+Bo'Bo'+2'2'+2'2'+Bo'Bo'+2'2'+Bo'Bo'
Number of bogies	16
Axle load	< 17 t
Acceleration 0–200 km/h	0.38 m/s ² (148 s)
Braking distance 300–0 km/h	3,700 m
Number of cars / train	8 (one 1st class, one bistro, six 2nd class)
Number of seats	601 (72 1st class, 528 2nd class, 1 position for wheelchair users)
Floor height	1,260 mm

High speed train set Velaro CRH3

for the Chinese Ministry of Railways (MOR)

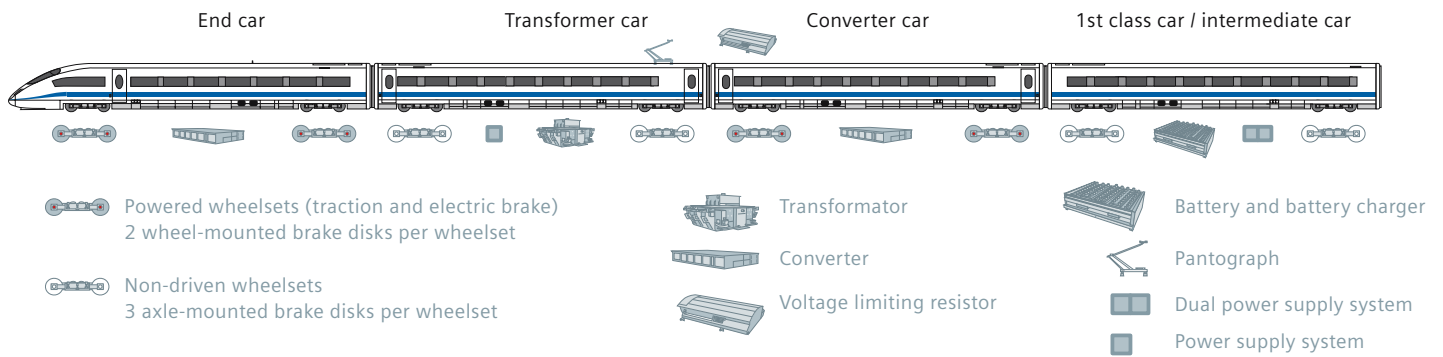

With an installed traction rating of 8,800 kW, the Velaro CN is designed for a maximum operating speed of 300 km/h. During braking, this power can be converted again and fed back into the overhead line.

Ride comfort and safety are guaranteed by the proven running gear technology from Siemens.

Automatic control and protection of the train is performed by an operations control system developed by Siemens for the Chinese market and that is based on Europe's standardized ETCS.

The proven train set concept

Like its predecessors – the ICE® 3 and Velaro E – the Velaro CN is a multiple unit train set in which the traction and the technical modules are distributed

under floor over the length of the train. This means that the full length of the train above floor is available to the passengers, offering some 20 % more passenger compartment space than conventional trains of the same length. This concept is becoming more and more popular with customers and is increasingly gaining headway internationally, for instance, for the high speed trains for the Russian State Railways (RZD), too.

The clear advantage:

Optimized performance characteristics. The train set concept stands out thanks to the following operating advantages:

- Improved utilization of the adhesion coefficient during acceleration because 50 % of the axles are driven.
- Ability to travel up sections with steep gradients up to 40 ‰.

- Due to the evenly distributed weight across the entire train set, the load on each individual wheelset is reduced. This goes easy on the track and reduces the maintenance requirements for the running gear. The load per wheelset is lower than the international standard of max. 17 metric tons.

Additional benefits:

- Ultra-smooth ride. The even distribution of weight also improves the running characteristics and thus travel comfort.
- The train length of 200 m has been perfectly chosen with regard to international regulations. It means that the train can run in double traction – with a total length of 400 m. The positive effect: The Velaro CN can run with two coupled train sets on a section of the track and then be divided into two trains for different final destinations.

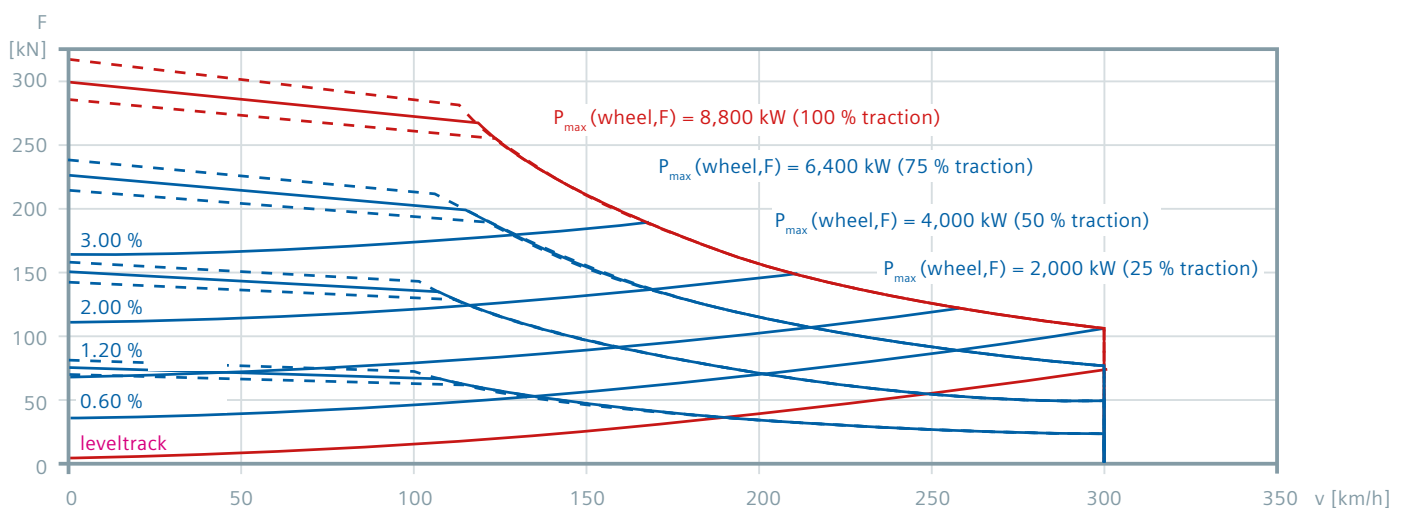

Tractive effort / speed curve

Impressive performance

The Velaro CN has four identical, independent converters. This principle provides clear advantages in continuous service:

- If one converter fails, it can be disabled without affecting the remaining units. This enables the train to safely reach its destination with 75 % of its maximum tractive effort.
- Low-maintenance three-phase asynchronous motors with cage rotors ensure high availability for productive service.
- The 8,800 kW power rating of the traction system has been chosen to guarantee excellent acceleration and deceleration values when the train is fully laden.

A train with a high seating capacity and plenty of comfort

The Velaro CN is the epitome of interior spaciousness. Thanks to its extra-wide car body, the train offers seats for 601 passengers – and plenty of comfort. Located at both ends of the train immediately behind the driver's cab is a 1st class lounge. One particular highlight is the transparent pane of glass between the lounge and the driver's cab, which gives the passengers an unobstructed view of the track. What's more, the lounge is fitted out with swivel seats, so that the passengers can always sit facing forward. The middle section of the train accommodates a further 1st class car, in which the wheelchair-users' position and the toilet for general use is located.

Immediately next to the 1st class car is the bistro car where passengers can enjoy snacks and beverages. This car also contains a customer service office. All remaining cars are 2nd class cars.

The result:

A spatial marvel that makes no compromises when it comes to comfort.

Exciting entertainment

The passenger information system is based on a wide range of experience and incorporates the latest technologies.

- In the 1st class car, large video screens that are clearly visible from every seat provide exciting entertainment.
- Compatibility with advanced media and formats – such as DVD and MP3 – makes sure that passengers have access to the latest productions in top quality.
- Five different stereo audio programs can be received at every seat in the 1st class car.

The latest news

- The central announcements for all passengers are coordinated from the customer service office via a computer with GSM interface.
- Announcements and internal communication can be made from six fixed intercom stations. The system offers the option of making group-selective announcements (e.g. for individual cars, classes).
- Passengers receive information via interior and exterior LED displays. Owing to the expected international audience, the information can be provided in English and Chinese.



End car 1st and 2nd class



Transformer car 2nd class



Intermediate car 2nd class



Bistro car 2nd class



1st class car



Intermediate car 2nd class



Transformer car 2nd class



End car 1st and 2nd class

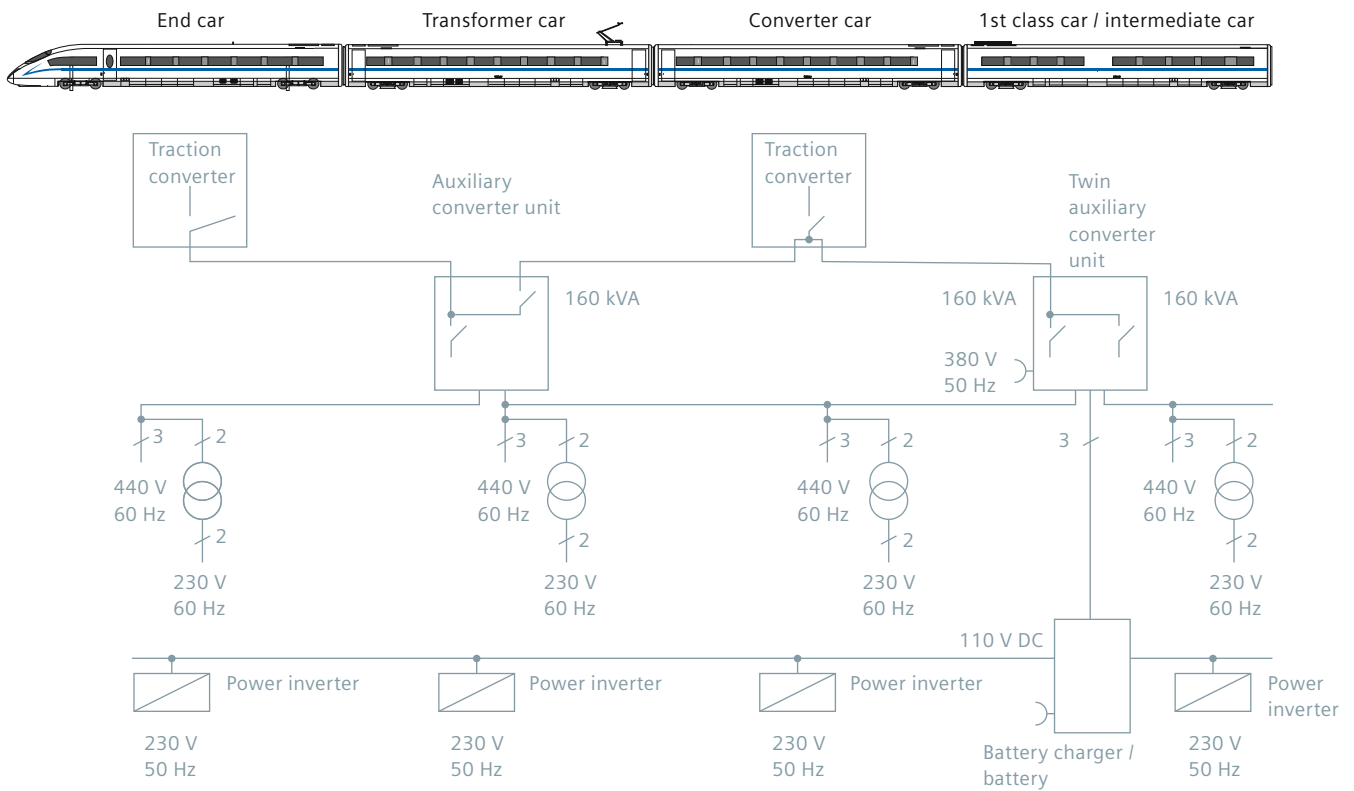

On-board power supply system

Perfect control

The Train Communication Network (TCN), consisting of the wired train bus (WTB) and multifunctional vehicle bus (MVB), ensures trouble-free and reliable data transfer, both between the traction units of a train set and between two coupled train sets. The consistently redundant design of the TCN system provides additional advantages:

- Significant improvement in the availability of the data communications paths
- Savings in terms of hardware, installation dimensions, weight, and lifecycle costs
- Increased data transparency and shorter data propagation delays through the reduced number of interfaces and sub-systems

Efficient on-board power supply system

An efficient on-board power supply system reduces power consumption and increases the cost effectiveness of a vehicle in the process. The on-board power supply system of the Velaro CN has been optimized with respect to the entire power supply system. The system topology chosen stands out due to the small number of energy conversion stages it comprises. Since every conversion stage leads to energy losses, the efficiency of the train's overall system has been able to be improved in this way.

Furthermore, redundancy structures ensure a reliable power supply for the auxiliaries in all operating situations. For instance, the auxiliary equipment power supply is maintained without interruption when the train passes sectioning points and is briefly isolated from the line.

Proven safety

The proven SF 500 bogies – which are rated for running speeds of up to 350 km/h – contribute to the exemplary lateral guidance of the train, maximizing stability for excellent running comfort. Even more important than rapid acceleration is rapid deceleration. The Velaro CN is equipped with a brake management system that controls automatic switchover between the electric and pneumatic brakes. Braking is predominantly performed in electric mode during routine service. Only when the line system is no longer able to absorb the electric braking energy of the traction motors does the brake management system gradually switch over to the pneumatic brake. This principle saves energy and also reduces mechanical wear.

Siemens AG
 Industry Sector
 Mobility Division
 Public Transit
 P.O. Box 3240
 91050 Erlangen
 Germany

trains.mobility@siemens.com
 www.siemens.com/mobility

