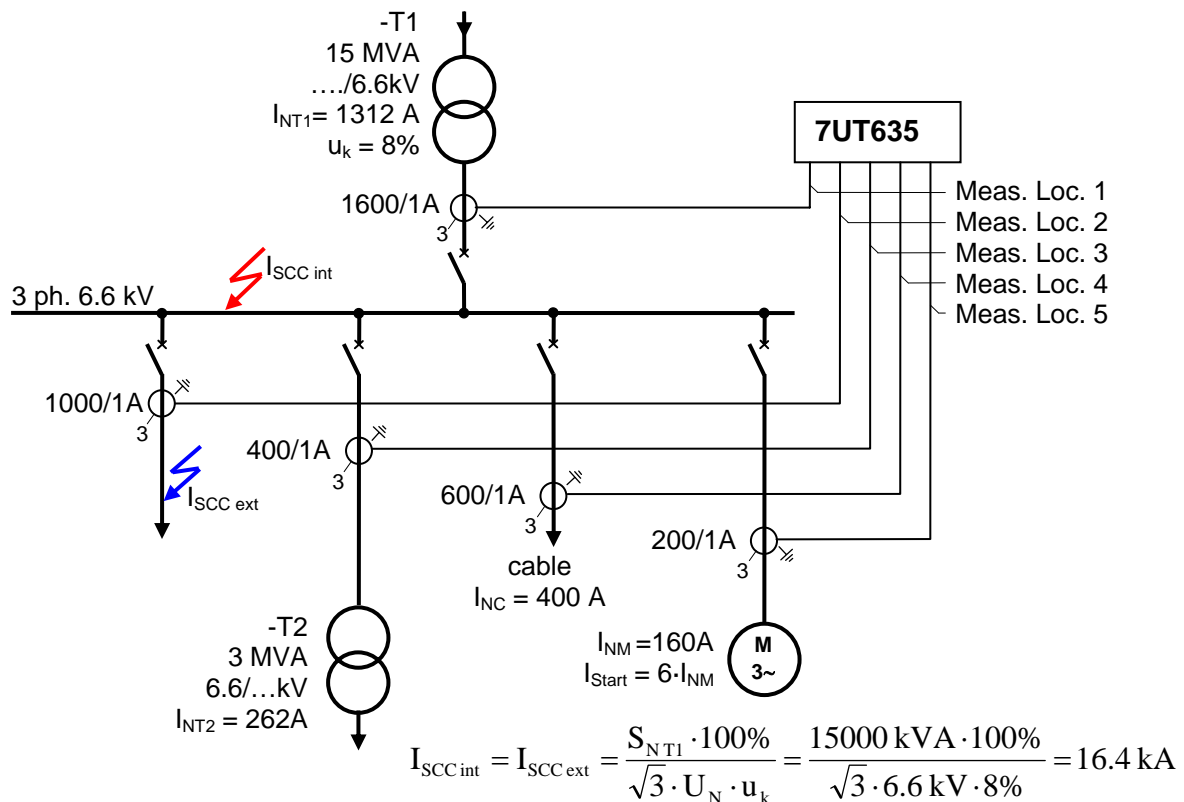

7UT6: Application for 3-phase busbar protection

7UT6 – Application 3-phase busbar protection

All SIPROTEC 7UT6 relays offer this features for 3-phase busbar protection with only one device. Only "3-phase busbar" has to be selected as the protected object. The maximum number of feeders depends on the relay type. The below description shows an application for 5 feeders using 7UT635.

7UT612	2 feeders (short line)
7UT613/633	3 feeders
7UT635	5 feeders

Fig. 1: Example with 7UT635**1. Operating current of the busbar**

A rated current for the entire busbar can be determined. The currents of all measuring locations assigned to the main object are converted such that the values of the differential protection are referred to this nominal current of the main protected object (I_{NO}), here the busbar.

If the current rating of the busbar is known, set this rated current in address 0371.

If no rated current of the busbar is defined, the highest of the rated currents of the sides (= feeders) can be selected. In Fig. 1, the nominal object current would be 1600 A.

1) address 0371 Primary Operating Current of Busbar = 1600A ($I_{NO} = 1600A$)

7UT6: Application for 3-phase busbar protection**2. Side currents**

The feeders of a busbar may be rated for different currents. For instance, an overhead line may be able to carry higher load than a cable feeder or a transformer feeder. A primary rated current for each side (= feeder) of the protected object can be defined. These ratings may differ from the rated currents of the associated current transformers. Fig. 1 shows an example for a busbar with 5 feeders.

2a) address 0372 Primary Operating Current Side 1 = 1312A

2b) address 0373 Primary Operating Current Side 2 = 1000A

2c) address 0374 Primary Operating Current Side 3 = 262A

2d) address 0375 Primary Operating Current Side 4 = 400A

2e) address 0376 Primary Operating Current Side 5 = 160A

For an assigned Overcurrent- or Overload function to one of the sides (for example side 3), the nominal current for this function is the setting in address 037x (for side 3: 262 A

(7UT613, 633, 635 **V4.6**: 3 Overcurrent phase und 2 Overload functions are available)

3. Differential current monitoring

Whereas high sensitivity of the differential protection is normally required for transformers, reactors, and rotating machines in order to detect even small fault currents, high fault currents are expected in case of faults on a busbar or a short line so that a higher pickup threshold (above rated current) is conceded here.(refer to 5.)

This allows for a continuous monitoring of the differential currents on a low level.

A small differential current in the range of operational currents indicates a fault in the secondary circuit of the current transformers. This monitor operates phase segregated.

When, during normal load conditions, a differential current is detected in the order of the load current of a feeder, this indicates a missing secondary current, i.e. a fault in the secondary current leads (short-circuit or open-circuit). This condition is annunciated with time delay.

The differential protection is blocked in the associated phase at the same time.

The function can be set to **ON** and **OFF** in address 1208 . Its use only makes sense if one can distinguish clearly between operational error currents caused by missing CT currents and fault currents

caused by a fault in the protected object.

The pickup value (address 1281) must be high enough to avoid a pickup caused by a transformation error of the current transformers and by minimum mismatching of different current transformers.

On the other hand, the pickup value must lie clearly below the pickup value of the differential protection

(address 1221) otherwise no differentiation between operational errors caused by missing secondary currents and fault currents due to short-circuit in the protected object would be possible.

The pickup value is referred to the rated current of the protected object. Time delay (address 1282) applies to the annunciation and blocking of the differential protection.

This setting ensures that blocking with the presence of faults (even of external ones) is avoided.

The time delay is usually about some seconds.

In Fig.1 the lowest load current is 160A (motor/side5).

Setting = below-160A/1600A. But minimum possible setting is 0.15 I/InO. Therefore:

3) address 1281 Pickup Value of diff.Current Monitoring = 0.15 I/InO

7UT6: Application for 3-phase busbar protection**4. Feeder Current Guard**

Another feature is provided for protection of mini-busbars or short lines. This feeder current guard monitors the currents of each phase of each measuring location of the protected object.

The pickup value (address 1210) is referred to the operational current of the individual side (addresses 0372....0376)!! With setting address 1210 = 0 (pre-setting) this release criterion will not be used. If the feeder current guard is set (i.e. to a value of > 0), the differential protection will not trip before the release criterion is given.

The setting should be above the load current of each side (feeder)

4) address 1210 I> for Current Guard = 1.20 I/InS

For this example: Current Guard release when

$I_{\text{Side 1}} \geq 1.2 \cdot 1312\text{A}$ or $I_{\text{Side 2}} \geq 1.2 \cdot 1000\text{A}$ or $I_{\text{Side 3}} \geq 1.2 \cdot 262\text{A}$ or $I_{\text{Side 4}} \geq 1.2 \cdot 400\text{A}$ or $I_{\text{Side 5}} \geq 1.2 \cdot 160\text{A}$

(The signal 5670 "Diff I Release" appears only, when there is 5631 "Diff picked up" at the same time)

5. Setting for $I_{\text{Diff}}>$

This setting should be above the maximum load. The maximum load in this example can be assumed as $I_{\text{NT1}} = 1312\text{ A}$:

If one of the CT's is not connected, e.g. broken conductor, the differential protection will not pick up under normal load conditions.

5a) address 1221 Pickup Value of Differential Curr. = 1.00 I/InO (InO = 1600A)

For the example in Fig. 1 even the starting current of the motor ($6 \cdot 160\text{A} = 960\text{ A}$) and also the inrush current of transformer -T2 would be below InO, but this is not recommended.

Due to the (relatively) high expected fault currents on a busbar, there can be one common slope with Base point 0 for the characteristic

5b) address 1241A Slope 1 of Tripping Characteristic = 0.50

5c) address 1242A Base Point for Slope 1 of Charac. = 0.00 I/InO

5d) address 1243A Slope 2 of Tripping Characteristic = 0.50

5e) address 1244A Base Point for Slope 2 of Charac. = 0.00 I/InO

Attention: For applications where "Increase of trip char. during start" (address 1205 = ON) is used, the factor for increasing (address 1252A) should be not higher than **1.6**, otherwise slope = 0.5 during start will become equal or close to 1 → no tripping area anymore.

6. Setting for $I_{\text{Diff}}>>$

The $I_{\text{Diff}}>>$ stage is not restraint e.g. by currents, harmonics, add-on stabilization etc.

In case of protected objects with high direct impedance (transformers, generators, series reactors), a threshold can be found above which a through-fault current never can increase. ($I_{\text{SCC int}} > I_{\text{SCC ext}}$)

For busbars however, such a threshold can not be found. ($I_{\text{SCC int}} = I_{\text{SCC ext}}$)

Therefore the $I_{\text{Diff}}>>$ stage can not be used.

6) address 1231 Pickup Value of High Set Trip = oo I/InO

7UT6: Application for 3-phase busbar protection

Fig. 2: 7UT6 tripping characteristic for 3 phase busbar

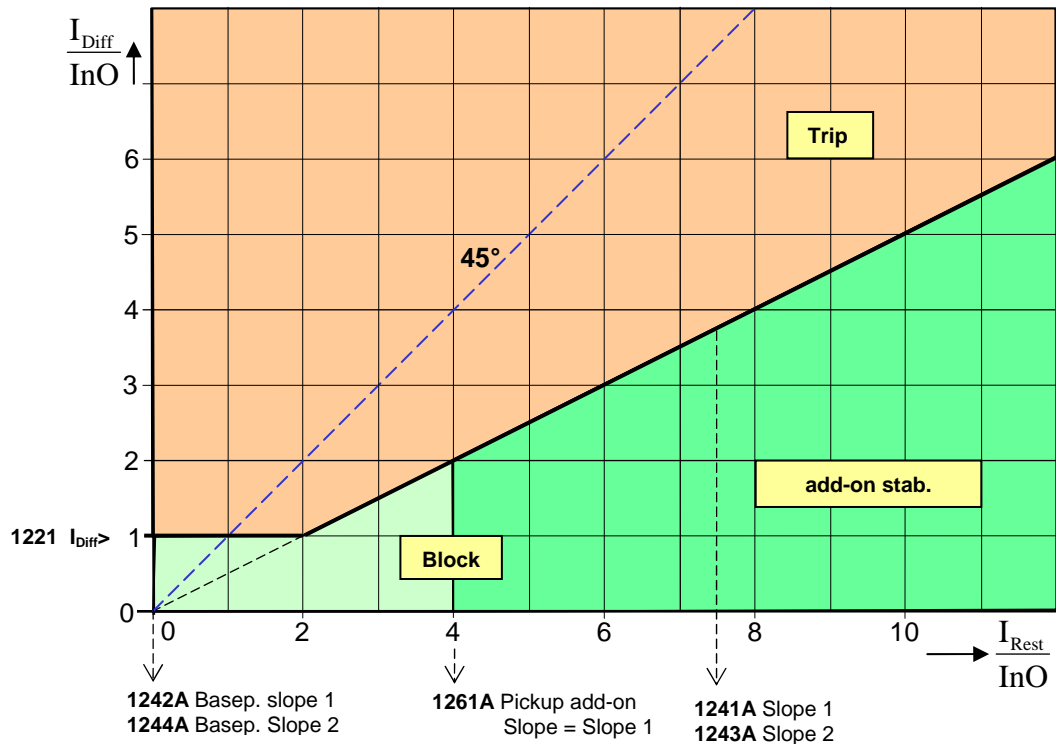

7UT6: Application for 3-phase busbar protection**Settings for the application in Fig. 1****Device Configuration**

No.	Function	Scope
0105	Protection Object	3 phase Busbar
0112	Differential protection	Enabled
0120	DMT / IDMT Phase	Definite Time only example

Power System Data 1

No.	Settings	Value
CT-Numbers		
0211	Number of connected Measuring Locations	5
0212	Number of assigned Measuring Locations	5

CT-Assign

0254	Auxiliary CT IX4 is used as	not connected	*)
0256	Type of auxiliary CT IX4	1A/5A current input	*)

Busbar

0370	Rated Primary Voltage Busbar	6.6 kV	**)
0371	Primary Operating Current of Busbar	1600 A	1)
0372	Primary Operating Current Side 1	1312 A	2a)
0373	Primary Operating Current Side 2	1000 A	2b)
0374	Primary Operating Current Side 3	262 A	2c)
0375	Primary Operating Current Side 4	400 A	2d)
0376	Primary Operating Current Side 5	160 A	2e)

Funct.

0420	DMT / IDMT Phase assigned to	Side 3
------	------------------------------	--------

CT's

0511	CT-Strpnt. Meas.Loc.1 in Dir. of Object	YES
0512	CT Rated Primary Current Meas. Loc. 1	1600 A
0513	CT Rated Secondary Current Meas. Loc. 1	1 A
0521	CT-Strpnt. Meas.Loc.2 in Dir. of Object	YES
0522	CT Rated Primary Current Meas. Loc. 2	1000 A
0523	CT Rated Secondary Current Meas. Loc. 2	1 A
0531	CT-Strpnt. Meas.Loc.3 in Dir. of Object	YES
0532	CT Rated Primary Current Meas. Loc. 3	400 A
0533	CT Rated Secondary Current Meas. Loc. 3	1 A
0541	CT-Strpnt. Meas.Loc.4 in Dir. of Object	YES
0542	CT Rated Primary Current Meas. Loc. 4	600 A
0543	CT Rated Secondary Current Meas. Loc. 4	1 A
0551	CT-Strpnt. Meas.Loc.5 in Dir. of Object	NO
0552	CT Rated Primary Current Meas. Loc. 5	200 A
0553	CT Rated Secondary Current Meas. Loc. 5	1 A

*) not important for this example

**) only important if a 7UT613, 633 device is used and a voltage relevant function like over excitation is enabled

7UT6: Application for 3-phase busbar protection

No.	Settings	Value
General		
1201	Differential Protection	ON
1205	Increase of Trip Char. during Start	OFF
1208	Differential Current monitoring	ON
1210	I> for Current Guard	1.2 I/InS 4)
I-Diff		
1221	Pickup Value of Differential Curr.	1.00 I/InO 5a)
1226A	T I-DIFF> Time Delay	0.00 s
1231	Pickup Value of High Set Trip	oo I/InO 6)
1231A	T I-DIFF>> Time Delay	oo sec
Characteristic		
1241A	Slope 1 of Tripping Characteristic	0.50 5b)
1242A	Base Point for Slope 1 of Charac.	0.00 I/InO 5c)
1243A	Slope 2 of Tripping Characteristic	0.50 5d)
1244A	Base Point for Slope 2 of Charac.	0.00 I/InO 5e)
1251A	I-RESTRAINT for Start Detection	0.10 I/InO *)
1252A	Factor for Increasing of Char. at Start	1.0 *)
1253	Maximum Permissible Starting Time	5.0 sec *)
1261A	Pickup for Add-on Stabilization	4.00 I/InO
1262A	Duration of Add-on Stabilization	15 Cycle
1263A	Time for Cross-blocking Add-on Stabiliz.	15 Cycle
I-Diff Monitor		
1281	Pickup Value of diff.Current Monitoring	0.15 I/InO 3)
1282	T I-DIFF> Monitoring Time Delay	2 sec

*) not important for this example

No.	Settings	Value
Time overcurrent Phase		
DMT		
2012	I>> Pickup	4.00 I/InS
2013	T I>> Time Delay	0.10 sec
2015	I> Pickup	1.30 I/InS
2016	T I> Time Delay	5.00 sec
InS in this case = 262A (side 3)		