

Installation Instructions

⚠ DANGER

Hazardous voltage. Will cause death or severe injury.

Turn off and lock out all power supplying circuit breaker before installing.

SAFETY INSTRUCTIONS

NOTE: These instructions outline the recommended installation procedure.

The term circuit breaker, used in these instructions, includes motor circuit interrupters and molded case switches.

This device attaches to the mounting panel and circuit breakers as shown in Fig. 1. Installation of the Mechanical Interlock prevents use of internal accessories in the right pole of the circuit breakers.

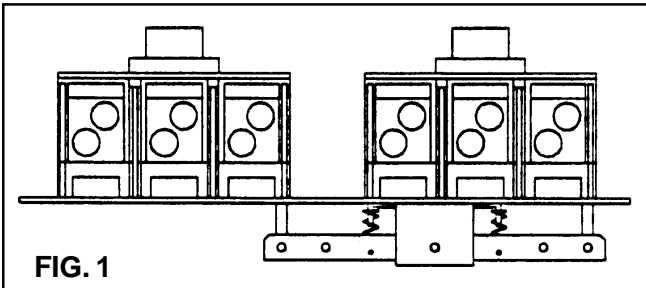

NOTE: See installation instructions provided with circuit breaker frame and trip unit for additional details.

CIRCUIT BREAKER PREPARATION—FIG. 2

1. Turn off and lock out all power supplying circuit breaker or frame before removing cover and while cover is removed.
2. Remove terminal cover and shield from load side of breaker frame.
3. Remove load cover from breaker frame. Three #8-32 x 3/8 screws and two #10-32 x 2-1/4 screws.

Note: Prior to lowering trip unit into place remove the socket head cap screw and the Belleville spring washer from the right pole of the trip unit. Discard the screw and washer.

4. Lower the trip unit into place as shown. The latch pin on the trip unit must seat into frame slots on both sides. The circuit breaker handle may be removed to ease assembly.
5. Secure trip unit to frame. Tighten the two 5/16-18 socket head cap screws on left and center poles to 140 In.-Lbs.[15.8 N/m].

All dimensions are in inches[millimeters].

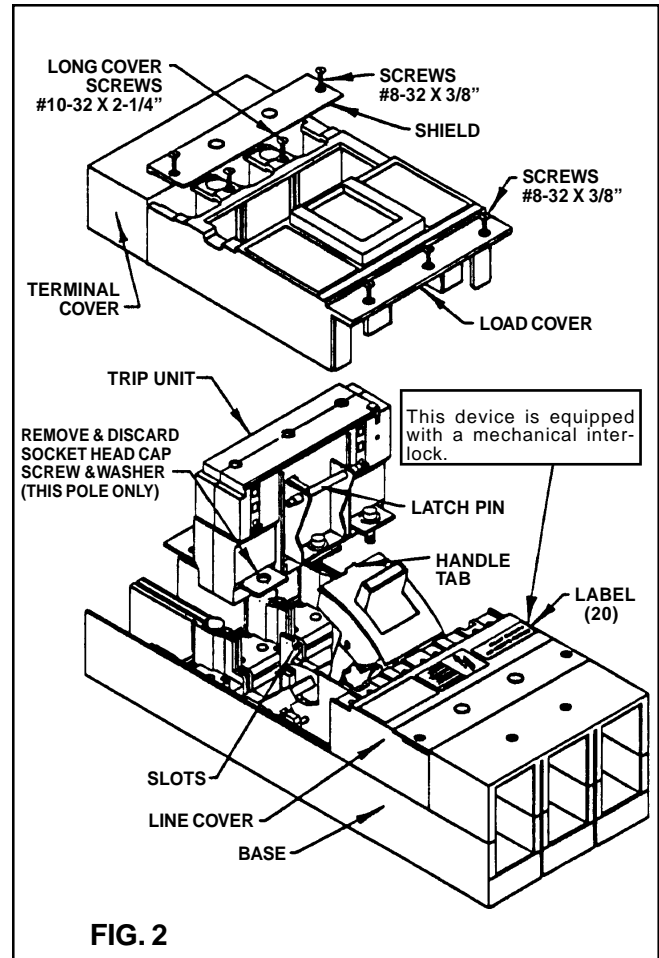



Installation Instructions

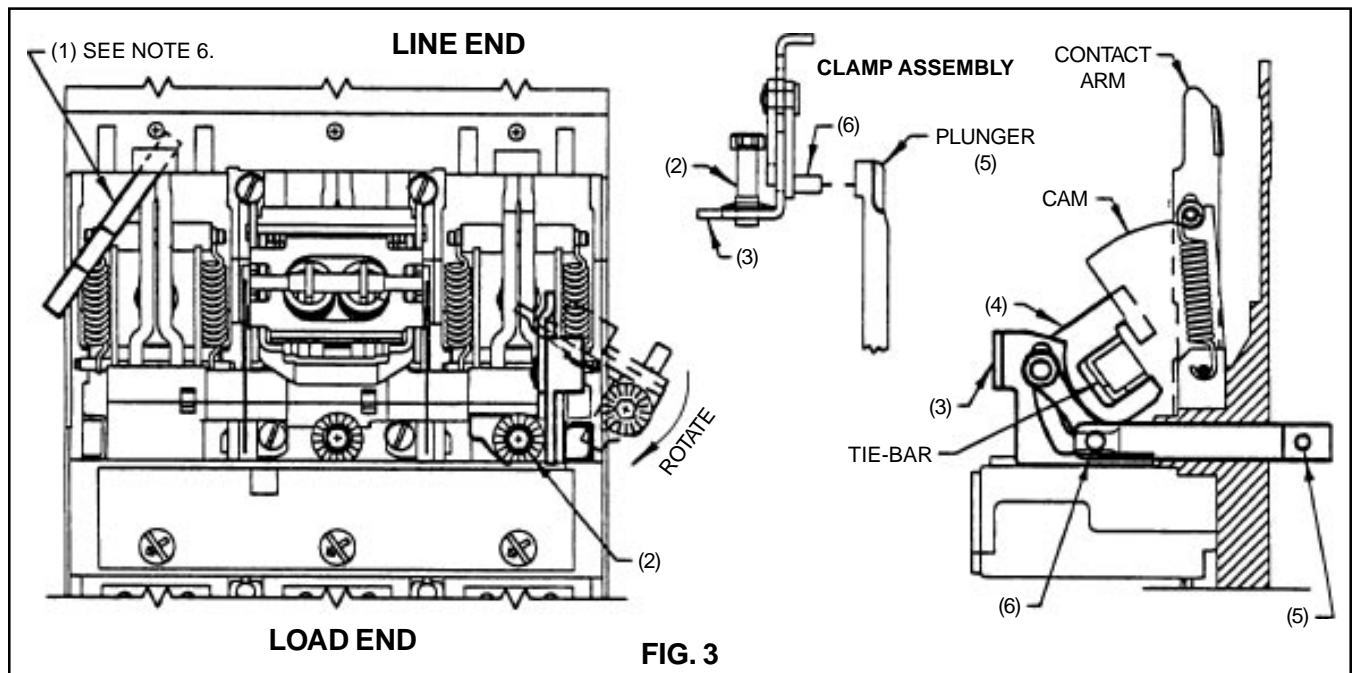

CAUTION: If not installed per these instructions, personal injury could result.

6. While pressing contacts downward to cause circuit breaker to close, insert safety block (1) into the line cover slot on the left pole as shown in Fig. 3 to secure the contact in the CLOSED position. Slowly release the contacts and confirm that the contacts are held in the CLOSED positions.
7. Attach the clamp assembly and plunger. See Fig. 3.
 - a. Partially engage the captive socket head cap screw (2) threads into support (3) threads as shown in clamp assembly detail in Fig. 3.
 - b. Place front edge of clamp (4) over the right hand corner of the cam, pushing the clamp downward to align with the tie-bar. Rotate the clamp assembly over the tie-bar and slide the clamp assembly approx. 1/2 inch to the left.
 - c. Insert the plunger (5), as shown in Fig. 3,

into the access hole in the base of the circuit breaker.

- d. Slide the clamp assembly to the right while inserting the pin (6) into the plunger hole.
 - e. Secure the assembly in place using the cap screw (2). Tighten the screw to 140 In.-Lbs.[15.8 N/m].
8. Press the contacts downward and carefully remove the safety block (1).

CAUTION: Release the contacts carefully to prevent personal injury.

9. Replace the circuit breaker handle if removed; note tab on handle must be toward load end. Replace the load cover and secure it in place using three #8-32 screws on the line side of the circuit breaker and two #10-32 screws on the load end. Tighten all cover screws to 25 In.-Lbs.[2.8 N/m].



Installation Instructions

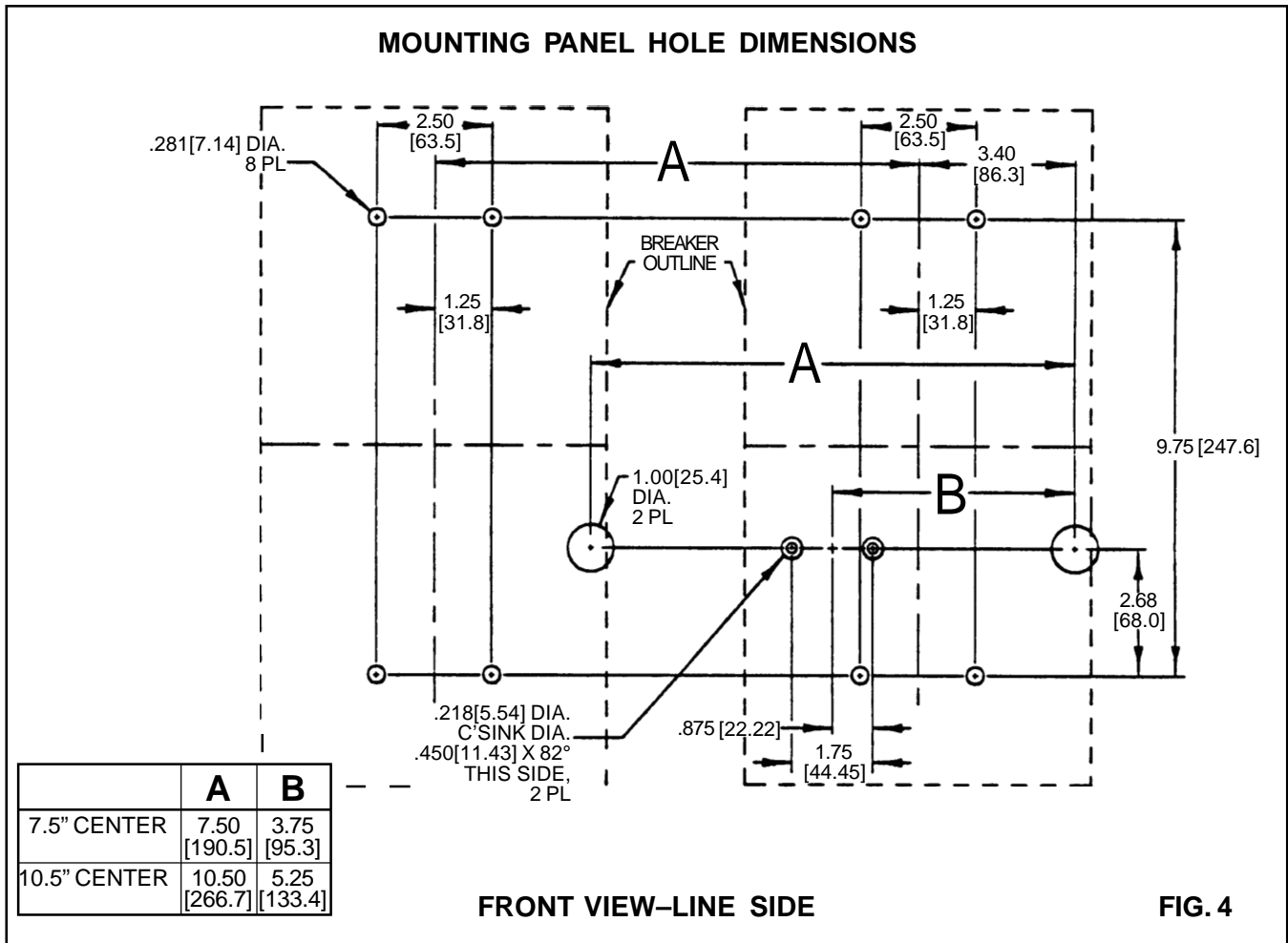

PREPARE THE MOUNTING PANEL—FIG. 4
 Mount the circuit breakers and the bracket on one single .135[3.43] inch thick (10 GA) steel panel. A crossbrace is recommended to prevent flexing of the mounting panel.
CAUTION: Malfunction of the Mechanical Interlock could occur if the dimensions shown in Fig. 4 are not maintained. This could result in equipment damage.

ATTACH BRACKET AND CIRCUIT BREAKERS—FIG. 5
 10. Attach the bracket (7) to the rear of the mounting panel using the two #10-32 x 1/2 flathead screws (8), lockwashers (9), and nut (10). Tighten the nuts to 32 In.-Lbs.[3.61 N/m].
 11. Add circuit breakers to the mounting panel. Carefully position circuit breaker over 1.00[25.4] dia. hole in panel to prevent damage to the protruding plunger. Use Cat. No. MSLMD mounting screw kit to fasten circuit breakers to the mounting panel. Tighten the 1/4-20 mounting screws to 75 In.-Lbs.[8.47 N/m]. Replace the terminal covers and shields and tighten the screws to 25 In.-Lbs.[2.82 N/m].



Installation Instructions

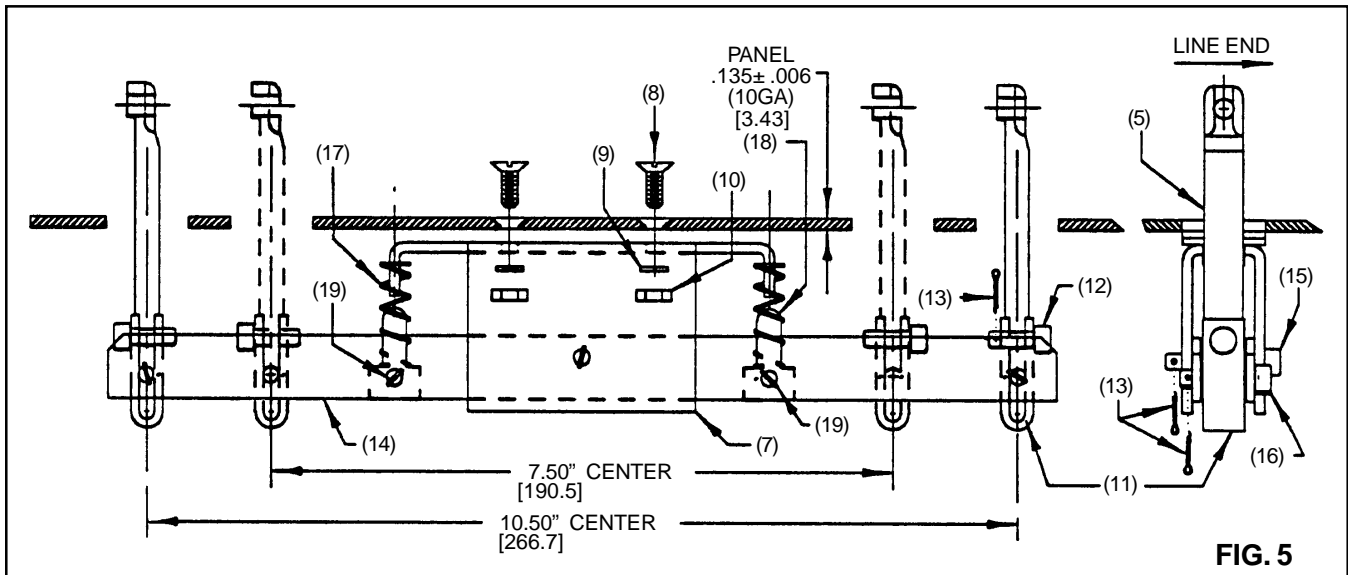

ROCKER ARM ASSEMBLY—FIG. 5

12. Assemble plunger connectors (11) to end of plungers (5) and insert .188[4.76] dia. x .74 pins (12) through plunger connector (11) and plunger (5). Insert cotter pins (13) into hole of pins (12) and spread ends.
13. Attach rocker arms (14) to bracket (7) using .188[4.76] dia. x 1.38[35.0] pin (15) as shown. Insert cotter pin (13) into hole of pin (15) and spread ends.
14. Attach rocker arms (14) to plunger connectors (11) using .188[4.76] dia. x 1.09[27.7] pin (16) as shown in Fig. 5. Insert cotter pin (13) into hole of pin (16) and spread ends.
15. Attach springs (17) to bracket (7) and secure to rocker arms (14) using spring adapters (18) and 1/8 dia. x 1-1/2" cotter pin (19) and spread ends.
16. Peel off protective backing from adhesive labels (20) and attach labels to front of each circuit breaker as shown in Fig. 2.

CHECK OPERATION

17. Check "ON-OFF" functions of each circuit breaker. Confirm that each circuit breaker cannot be turned "ON" if the other circuit breaker is "ON".
18. The interlock will prevent closing of one or both of the circuit breakers if they are simultaneously driven to the ON position. Check this function by manually synchronizing "TURN ON" of both circuit breaker handles.

NOTE: Avoid unnecessary simultaneous "TURN ON" operations. They cause high mechanical loading of the circuit breaker and interlock components.

If, after completing steps 17 and 18, both circuit breakers can be turned ON, check for flexing of the mounting panel.