



Document No: IOM-002

DigiTRON Single Connectors Installation, Operations and Maintenance Manual

Protection, Storage, Shipment, Unpacking, Deployment
& Maintenance Instructions

www.siemens.com/energy/connector-operations-manual

This page records the revision status of the entire document and its authorisation for issue. When a page or pages of the document are revised, the number of the page affected will be entered in the Page Affected/Remarks Column and a vertical margin line will appear against the latest amended text.

DigiTRON Single Connectors Installation, Operations and Maintenance Manual

The contents of this document are confidential and must not be disclosed to any third party without prior consent in writing from Siemens Subsea Connectors a division of Siemens plc.

5	R.Wyatt	26.02.2020	J.Hardisty	26.02.2020	Safety warning added regarding differential pressure rated products not to be used for fixed pressure vessel installations.
4	P.Westwell	27.11.14	B.Leach	27.11.14	Misalignment tolerances updated, section 5 warning note added.
3	P.Westwell	29.4.2014	B.Leach	29.4.2014	New design cover and complete document reformat.
2	P.Westwell		B.Leach	12.3.2014	Re-format, various text amendments,
1	P.Westwell		B.Leach	1.8.2013	First issue
	By	Date	By	Issue Date	
Rev	Compiled		Checked		Remarks / Pages Affected
© Siemens Subsea Connectors, (a division of Siemens plc), Subsea Excellence Centre, Ulverston, Cumbria, LA12 9EE, England					Page No. 2

Contents

1.	INTRODUCTION.....	4
2.	SCOPE	4
3.	ABBREVIATIONS	5
4.	HEALTH & SAFETY	6
5.	PROTECTION, HANDLING AND SHIPMENT	6
6.	UNPACKING	8
7.	STORAGE	8
7.1	Short Term Connector Storage	8
7.2	Long Term Connector Storage	8
7.3	Long term storage of elastomers	8
8.	REFERENCE DOCUMENTS	9
9.	INSTALLATION EQUIPMENT	9
10.	STAB PLATE CONNECTORS	9
11.	DIVER CONNECTORS.....	15
12.	ROV CONNECTORS.....	16
13.	DUMMY / PARKING CONNECTORS	18
14.	INSTALLATION OF FLYING ROV DUMMY CONNECTORS	19
14.1	Alignment and Mating.....	19
14.2	Mechanical Forces During Mating / De-Mating	22
14.3	Maximum Misalignment Values	22
14.4	Post Mating Checks (DigiTRON ROV only):.....	22
14.5	ROV Mating / de-mating forces (DigiTRON).....	22
14.6	Mechanical Forces During Mating / De-Mating:	22
14.7	De-Mating	23
15.	TEST CONNECTORS.....	24
15.1	TESTING OF SINGLE CONNECTORS	24
16.	DigiTRON CONNECTOR SPECIFICATION	25
17.	MAINTENANCE.....	26
17.1	Protection of Receptacle Contact Pins	26
17.2	Over Current Capacity.....	26
17.3	Marine Growth and Calcareous Deposits	26
18.	INFORMATION AND NOTES / HEALTH & SAFETY FEEDBACK.....	27
19.	SIGN OFF SECTION	27

1. INTRODUCTION

This manual details procedures for the following:
Installation Operation and Maintenance of DigiTRON Single Connectors.

2. SCOPE

This manual details installing the DigiTRON family of connectors when supplied as loose connectors. Electrical and mechanical specification of connectors is also detailed in this document.



The back page includes a sign off point which must be completed by the user of this manual.

Any information, records or Health and Safety feedback that needs to be detailed, can be recorded in the punch list at the rear of the document.

3. ABBREVIATIONS

A	Ampere
AC	Alternating Current
Assy	Assembly
API	American Petroleum Institute
AWG	American Wire Gauge
BOM	Bill of Material
°C	Degree Celsius
CE	Community European
Comms	Communication Signal
CP	Cathodic Protection
DC	Direct Current
DWG	Drawing
EFL	Electrical Flying Leads
EMF	Electrical Magnetic field
FAT	Factory Acceptance Test
IR	Insulation Resistance
ISO	International Organization for Standardization
ITP	Inspection Test Plan
K	Kelvin
LTC	Long Term Cover
M	Metres
Max.	Maximum
MFG	Manufacturer
Min.	Minimum
No.	Number
ROV	Remotely Operated Vehicle
SI	Standard International
SRT	Site Received Test
SST	Stainless Steel
TBD	To Be Defined
TSP	Twisted Screened Pairs
UNS	Unified Numbering System for Metals and Alloys
V	Volt

4. HEALTH & SAFETY

	<p>Danger of electrocution: exposed live pins accessible by hand.</p> <p>Receptacle connectors (exposed male pins) must not be electrically energised without being mated to its correct mating half (including Test plug, Dummy plug, or plug on flying lead or harness).</p>
	<p>Danger of release of stored pressure.</p> <p>DigiTRON Products are designed for, and intended only for use in subsea applications e.g. in subsea control systems, and associated activities such as topside testing and commissioning of such systems.</p> <p>The DigiTRON Products are not designed to comply with the requirements of the Pressure Equipment Directive (2014/68/EU) and therefore, are not intended for incorporation into fixed top-side or land-based pressure vessels.</p>

Manual Handling, Lifting and Carrying are known to be the largest contributors to occupational ill-health. Ensure that mechanical handling aids are used if manual handling is inappropriate. Where manual handling is considered appropriate for the task safe lifting guidelines must be followed, e.g. adopt correct posture, consider team lifting, employ safe lifting technique, etc.

Only competent persons are permitted to perform tasks without supervision, if in doubt ask. Good Housekeeping avoids Slips Trips and Falls, keep your area clean and tidy.

It is the operator's responsibility to comply with current Company & regional health and safety legislation. Caution shall be exercised during assembly to ensure that fittings and hydraulic / pneumatic equipment are properly installed.

In the event of a safety incident or any safety improvement suggestions please contact the Health and Safety Department at prodsafe.gb@siemens.com and/or complete and return the punch list in section 18.

5. PROTECTION, HANDLING AND SHIPMENT

Siemens Subsea electrical connectors are manufactured primarily from materials such as 316L stainless steel (UNS S31603), and Super Duplex stainless steel (UNS S32550), and as such are designed to withstand harsh saliferous environments. However, the connector insert and exposed parts are susceptible to mechanical damage if not adequately protected. Dust caps or Acetal protective caps are fitted to all Siemens Subsea connectors before transport. Caps are recommended to remain in place until connectors are deployed subsea.

The connectors are generally relatively small items of equipment, and therefore, can be shipped singularly or in multiples. Care should be taken to protect the connector with either Instapak (or similar), bubble wrap or similar wrapping materials to avoid surface damage during transit. If large numbers are shipped in one consignment a suitably reinforced box will be necessary to withstand the weight. Dust caps or Acetal protective caps must be fitted at all times during transport.

WARNING: Please refer to product packaging for accurate lifting weight and ensure the appropriate lifting equipment and PPE are used during handling operations.

ACCEPTABLE PACKAGING FOR SHIPMENT



Instapak (or similar)



bubble wrap (or similar)

UNACCEPTABLE PACKAGING



If storage is carried out in saline conditions, e.g. on a ship's deck or hold, then full dummy connectors should be used to protect a receptacle connector and a protective cap to protect a plug connector. Bulkhead type connectors with exposed tailing wires should be packed and shipped in a suitably sized box to allow adequate space for the tailing wires without bending or kinking. If the connectors are assembled onto hoses these must be suitably coiled and secured with tape to prevent uncoiling during transit. The following bend radii are recommended for storage/transport of hoses.

AquaTRON 50, TC6A-700 – Minimum inside bend radii - 125mm

AquaTRON 75, TC6A-712 – Minimum inside bend radii - 180mm

Connectors are designed & qualified to withstand vibration that occurs during transportation and to withstand being dropped from a height of 1m whilst in packaging. Any connector-specific handling and transport advice is contained within the appropriate section further on in this document. Ensure that mechanical handling aids are used whenever possible to avoid manual handling.

6. UNPACKING

Remove wrapping material taking care to inspect for any surface damage or items that may have become separated from the connector, such as 'O' seals. Do not use a knife to cut the wrapping material, as this may cause damage to any elastomeric parts of the connector. Do not remove protective caps until connectors are ready for installation. On removal do not allow the hoses to drag over the edges of the packing crate. Connectors supplied in boxes must be stored in the box.

7. STORAGE

7.1 SHORT TERM CONNECTOR STORAGE

(Non-controlled warehouse / exposed storage and transportation)

Prior to installation /deployment the connectors are sensitive to environments where grit and dirt are present. To prevent ingress of the above, they should be stored in a clean dry area and be protected by their protective wrapping material or similar.

Protective caps must be fitted if supplied. (also refer to section 5)

No carbon steel must be present in the storage of the products.

Please note; Maximum storage temperature takes into account solar gain. Skin / Surface temperature must not exceed 70°C. Suitable protection must be used to ensure maximum storage temperature is not exceeded.

7.2 LONG TERM CONNECTOR STORAGE

The connectors must be stored in a clean dry area and be protected by bubble wrap or similar. Suitable protection caps must be fitted and the storage temperature should be between -40°C and 70°C. Humidity of the store room should be below 75%. Very moist or very dry conditions should be avoided. The Plug connector should be protected from strong sunlight and strong artificial light with a high ultra violet content. The connectors should not be allowed to come into contact with solvents, oil, greases or any other semi-solid materials. If glanded connectors are to be stored bolted into their interfaces ensure the cable entry point into the gland is covered to prevent water ingress.

No carbon steel must be present in the storage of the products

Please note; maximum storage temperature takes into account solar gain. Skin temperature must not exceed 70°C. Suitable protection must be used to ensure maximum storage temperature is not exceeded.

7.3 LONG TERM STORAGE OF ELASTOMERS

For the recommended storage of elastomeric components e.g. termination sleeves and cable boots, please refer to Siemens document MH006 - Procedure for Storage and Handling of Elastomeric Materials.

8. REFERENCE DOCUMENTS

- MH006** Siemens Subsea document - Procedure for Storage and Handling of Elastomeric Materials.
ASS-311 DIGITRON dry assembly of in-line connectors
ASS-376 DIGITRON assembly procedure for dummy connectors

9. INSTALLATION EQUIPMENT

Tools Required for installation:

1. ¼ inch drive torque wrench 0-25 Nm – with Metric Allen key drive
2. Loctite 243
3. Working class ROV with correct manipulator interface for Siemens paddle handle

10. STAB PLATE CONNECTORS

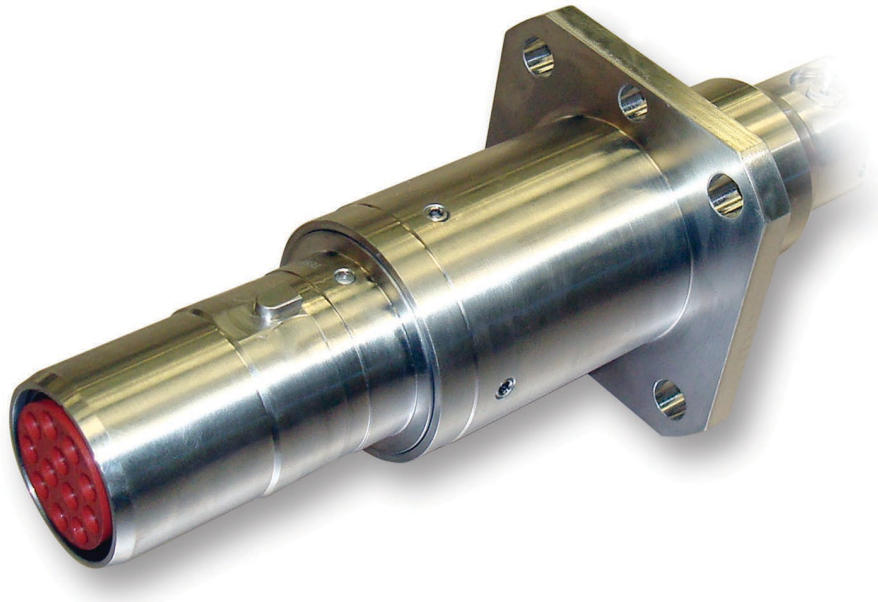

Figure 1

Image to show flange mounted connector.

Flange Mount

For stab plate connectors, there are 4 types of flange – Fixed, Floating, Split- Fixed and Split-Floating flange types. Split flanges allow the connector to be passed through an interface and the flange fitted at the front. In both cases, an M6 grub screw is supplied for tightening the flange to the connector body. Apply Loctite 243, screw into the M6 tapped hole on the bottom face of the flange and tighten to 3.5 Nm. In the case of the split flange, this can only be carried out after the flange has been fitted to the interface on-site. For stab plate connectors (metal to metal flange contact) mounting screws shall be torqued to 10-12Nm.

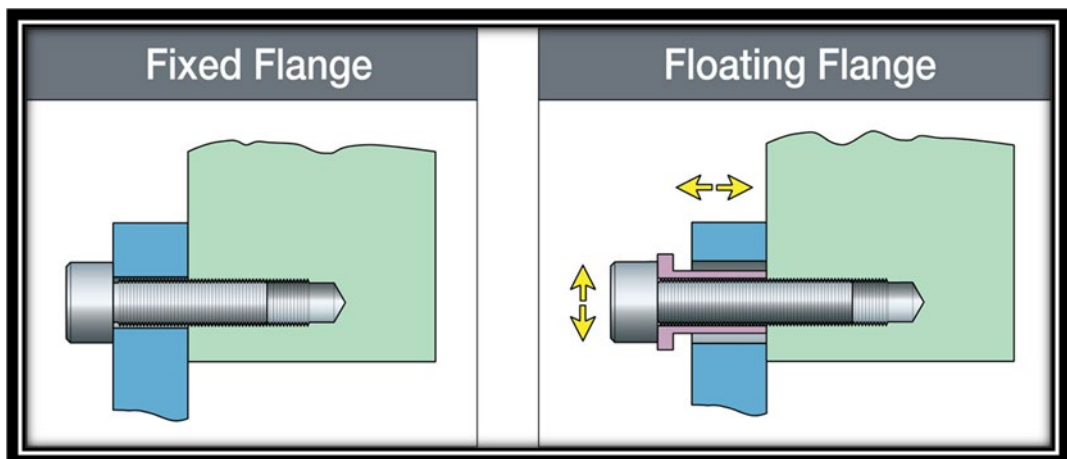

Figure 2

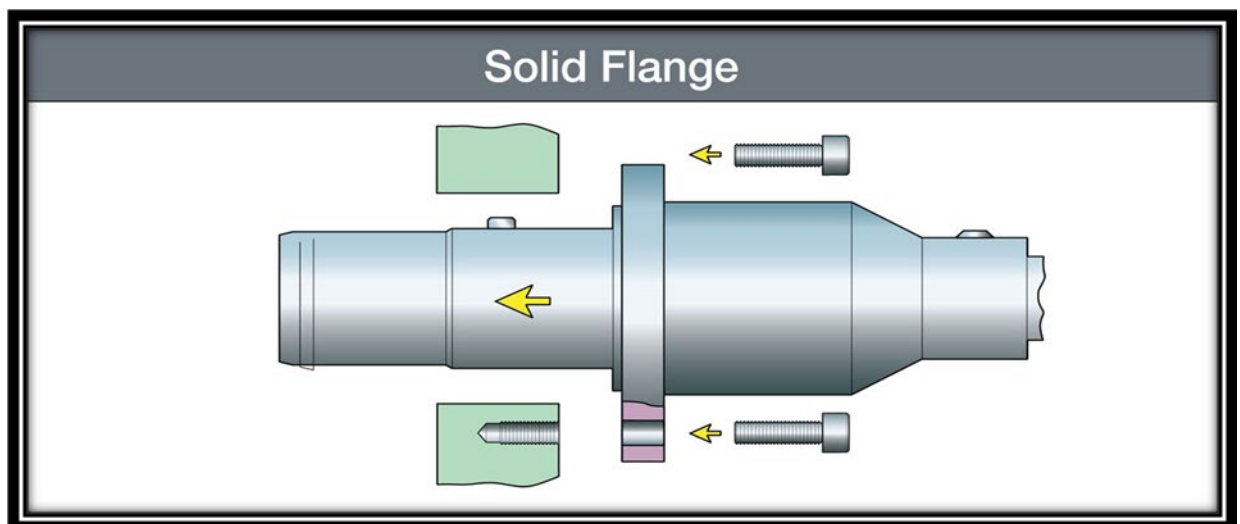

Figure 3

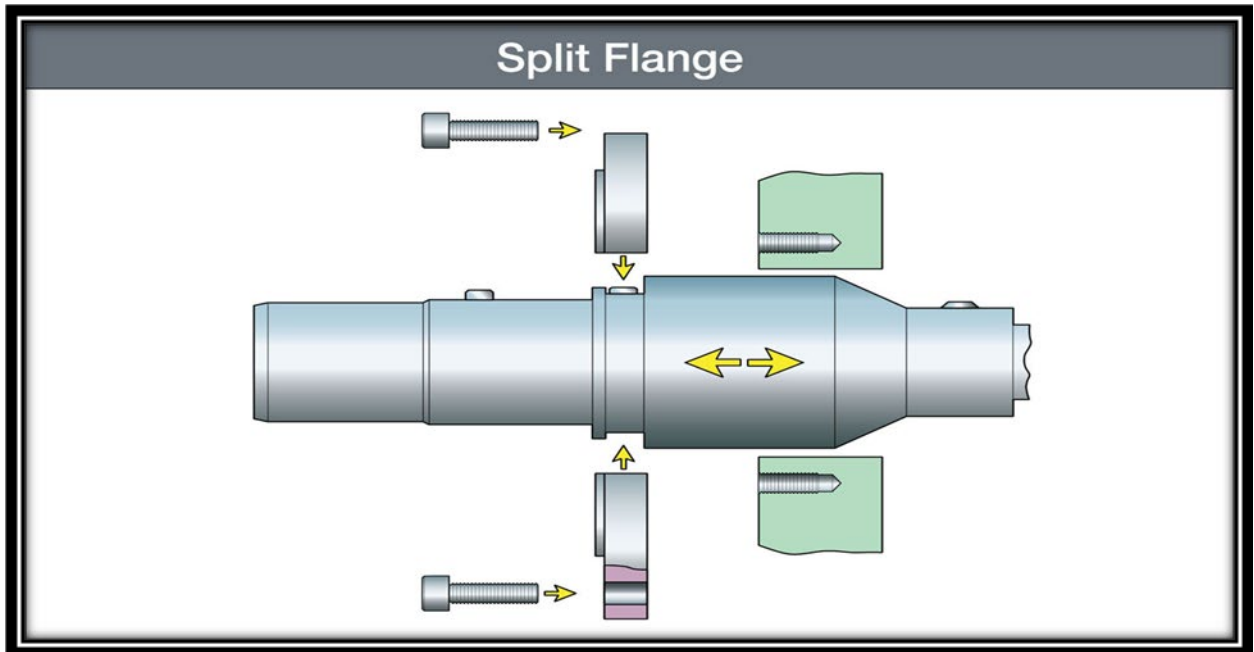

Figure 4

Floating flanges have larger fixing holes in the flange, and a steel top hat washer under the screw head. The larger hole means that if an attempt were made to fit the connector without the top hats, the screw head would pass straight through the hole, indicating that something was missing. Standard M6 cap screws are used for both fixed and floating mounted flanges.

Apply a spot of Loctite 243 to the threads of the cap head screws. For Diver mate / stab plate connectors (metal to metal flange contact) mounting screws shall be torqued to 10-12Nm.

- **Compliance**

One half of a stab mate connector pair must be allowed to float so that misalignment tolerances can be accommodated.

- **Misalignment tolerances:-**

Radial (mm) +/- 1,0mm
 Angular (°) +/- 0.7°
 Rotational (°) +/- 1.6°

- **Pre-Mating Checks**

Before mating, the receptacle connector should be checked for debris. The connectors have been designed to accommodate sand and silt contamination, however large pieces of debris should be removed. Use a water jet if subsea.

- **Partial Disconnection**

Partial disconnection with the contact pin remaining between the primary and secondary diaphragms is not recommended, as there is a risk of damaging the insulation. If it is necessary to operate the connectors partially mated, the connectors should be separated by 0.340-0.360" [8.6–9.2mm] from the nominal, mated, stab distance. In this condition the level of insulation between the contact pin and socket contact is reduced and the connector is relying on the primary seals within the plug. There is also an increased risk of insulation break down at voltages above 500V.

- **Interrupted Connection**

Interrupted connection (i.e. Partial mate to full de-mate) can be carried out without any adverse affect to connectors, as long as the power is off.

- **Cathodic Protection:**

Stainless steel 316L (UNS S31603) stab plate connectors must be connected to the CP (Cathodic Protection) system at all times. Super Duplex stainless steel (UNS S32550) connectors should be isolated from the CP system to reduce the slight possibility of hydrogen embrittlement

Installation Sealed Bulkhead

Inspect 'O' ring grooves for damage and debris prior to installation of 'O' rings.
Apply a small amount of DC4 grease to the interface 'O' rings and install on the connector, fit connector to interface ensuring correct orientation (unless otherwise stated ensure the key is at the 12-o'clock position).

Apply a spot of Loctite 243 to the threads of the cap head mounting screws and tighten to a torque of 10-12Nm for metal to metal flange contact.

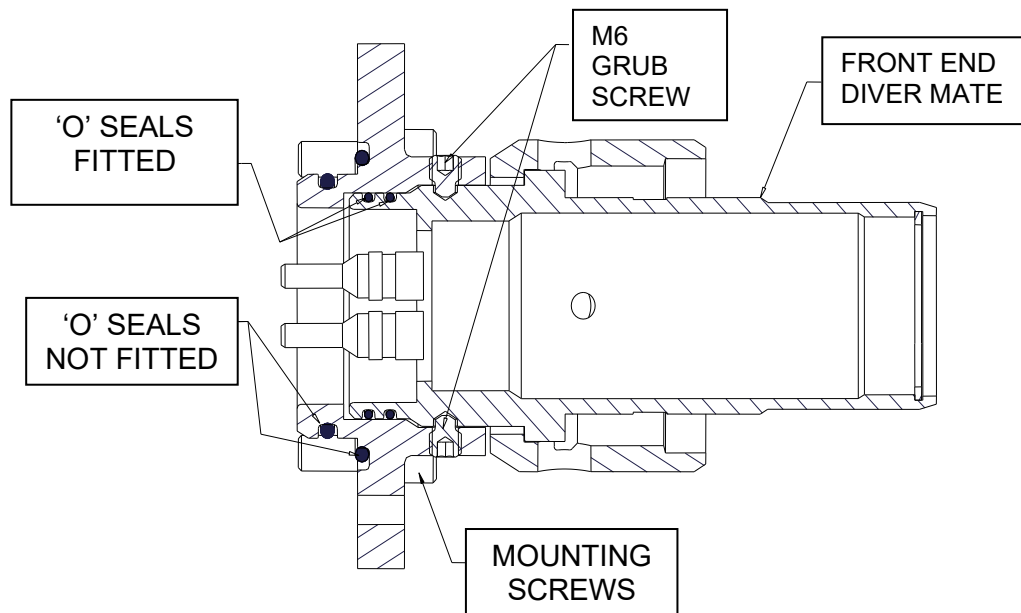

Figure 5.
 Sealed bulkhead diver mate plug connector

Bulkhead connectors with pigtail wires terminated should be treated with care, especially around the termination area and the termination area should not be bent. Excessive force should not be used to pull the wires. The connector should **not** be held or carried using the terminated wires.

Care must be taken to protect the tails on installation. The tails must be fed through the bulkhead without damage or kinking occurring. The connectors must be installed so that once they are fitted in place the tails will not be obstructed or snagged.

- **Misalignment tolerances:-**

Radial (mm)	+/- 1,0mm
Angular (°)	+/- 0.7°
Rotational (°)	+/- 1.6°

- **Pre-Mating Checks**

Before mating, the receptacle connector should be checked for debris. The connectors have been designed to accommodate sand and silt contamination, however large pieces of debris should be removed. Use a water jet if subsea.

- **Partial Disconnection**

Partial disconnection with the contact pin remaining between the primary and secondary diaphragms is not recommended, as there is a risk of damaging the insulation. If it is necessary to operate the connectors partially mated, the connectors should be separated by 0.340-0.360" [8.6-9.2mm] from the nominal, mated, stab distance. In this condition the level of insulation between the contact pin and socket contact is reduced and the connector is relying on the primary seals within the plug. There is also an increased risk of insulation break down at voltages above 500V.

- **Interrupted Connection**

Interrupted connection (i.e. Partial mate to full de-mate) can be carried out without any adverse affect to connectors, as long as the power is off.

- **Cathodic Protection:**

Stainless steel 316L (UNS S31603) stab plate connectors must be connected to the CP (Cathodic Protection) system at all times. Super Duplex stainless steel (UNS S32550) connectors should be isolated from the CP system to reduce the slight possibility of hydrogen embrittlement

11. DIVER CONNECTORS

- **Installation Flange mounted**

For Diver mate connectors (metal to metal flange contact) mounting screws shall be torqued to 10-12Nm

- **Installation Sealed Bulkhead**

Inspect 'O' ring grooves for damage and debris prior to installation of 'O' rings. Apply a small amount of DC4 grease to the interface 'O' rings and install on the connector, fit connector to interface ensuring correct orientation (unless otherwise stated ensure the key is at the 12-o'clock position).

Apply a spot of Loctite 243 to the threads of the cap head mounting screws and tighten to a torque of 10-12Nm for metal to metal flange contact.

- **Alignment**

These connectors have been designed to self-align during mating. All that is required is to ensure that the alignment pin on the plug connector is engaged in the alignment groove within the receptacle connector before screwing the clamp ring up.

- **Pre Mating Check**

Before mating, the receptacle connector should be checked for debris. The connectors have been designed to accommodate sand and silt contamination, however large pieces of debris should be removed using a water jet.

- **Mating**

The clamp ring should be rotated clockwise by hand until tight. The connectors are designed to remain clamped together with only firm hand tightness on the clamp ring. If a clamping torque is required this **MUST NOT** exceed 15 ft-lbs. [20Nm]. A 2-3" C-spanner or purpose made Siemens tool (T11367 – For size 10 connectors only) may be used to apply this torque.

- **Post Mating Checks**

Full engagement of the connectors can be checked through the viewing hole in the clamp ring. If the connectors are fully mated then no gap should be visible between the plug and receptacle.

- **Cathodic Protection**

Stainless steel 316L (UNS S31603) diver mate connectors must be connected to the CP (Cathodic Protection) system at all times. Super Duplex stainless steel (UNS S32550) connectors should be isolated from the CP system to reduce the possibility of hydrogen embrittlement.

12. ROV CONNECTORS

View to show ROV bulkhead connectors

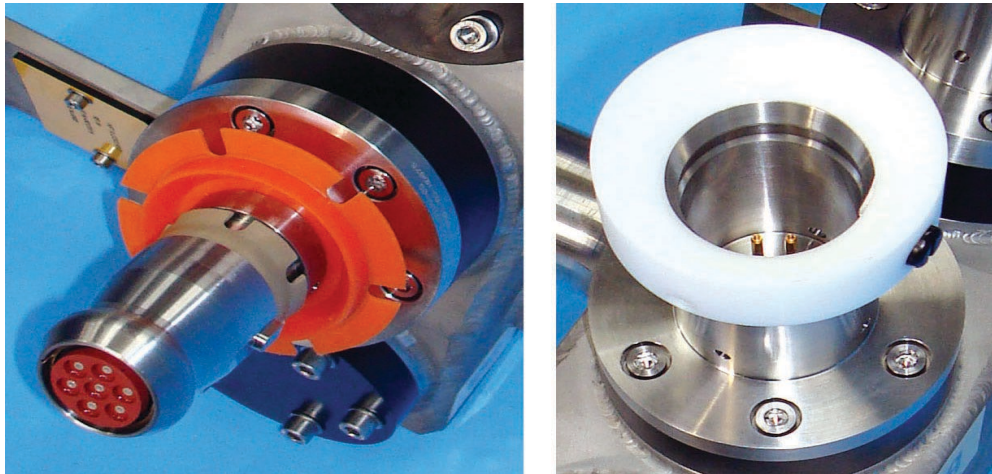

Figures 6 & 7

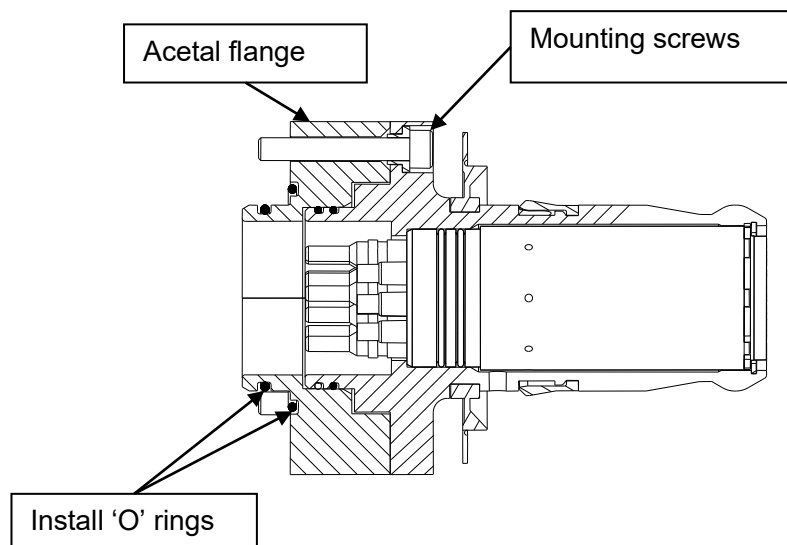

Figure 8.

Image shows section view to identify installation and parts

Installation

Inspect 'O' ring grooves for damage and debris prior to installation of 'O' rings. Apply a small amount of DC4 grease to the interface 'O' rings and install on the connector, fit connector to interface ensuring correct orientation (unless otherwise stated ensure the key is at the 12-o'clock position).

Apply a spot of Loctite 243 to the threads of the cap head mounting screws and tighten to a torque of 7 Nm.

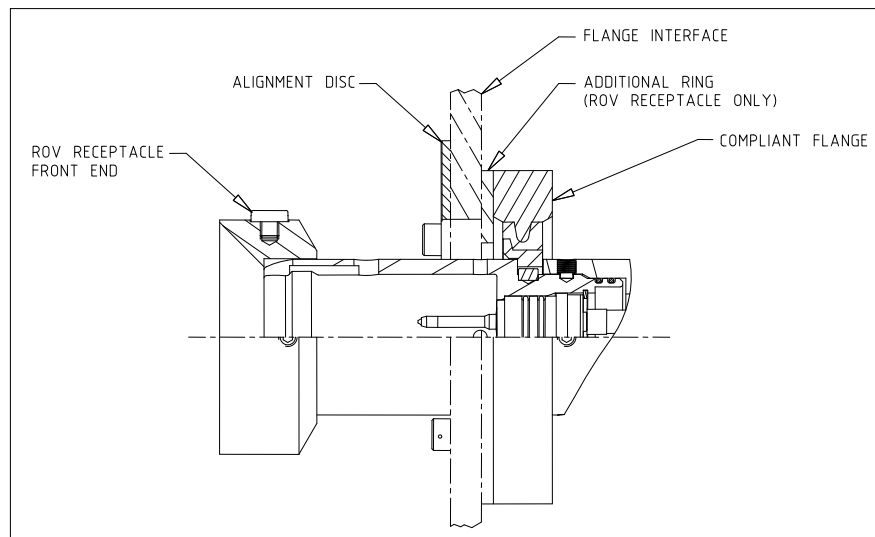

Figure 9.

Section view to show installation and parts of compliantly flange mounted connector

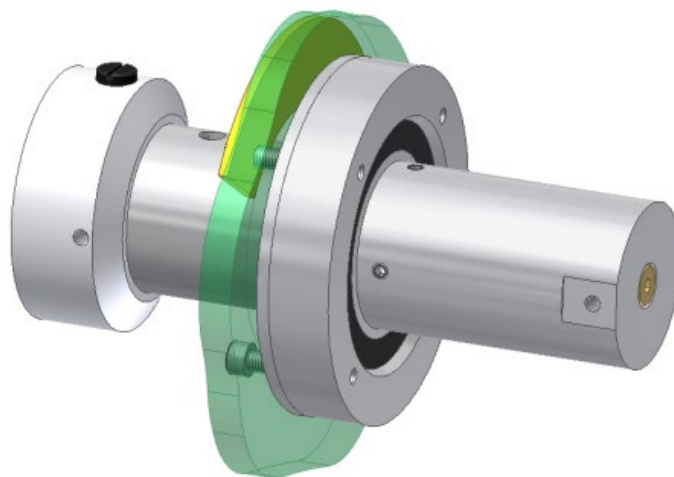

Figure 10.

Image shows compliantly mounted ROV Dummy Receptacle

13. DUMMY / PARKING CONNECTORS



Figure 11.
 Diver Flange Mount Dummy Plug

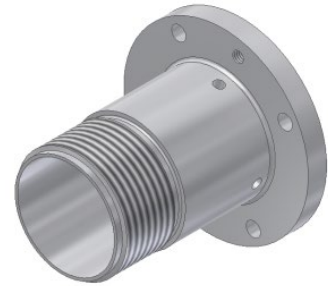

Figure 12.
 Diver Parking Receptacle



Figure 13.
 Stab Flange mounted receptacle

Installation of Flange mounted dummy connectors is the same procedure as none dummy connectors, so please follow the installation instructions in the relevant sections.

Section 10/11 – Diver and Stab Mate flange mounted connectors

Section 12 – ROV connectors Flange mount

14. INSTALLATION OF FLYING ROV DUMMY CONNECTORS



Figure 14.
Image to show Flying ROV dummy

14.1 ALLIGNMENT AND MATING

- DigiTRON connectors have been designed to self align during mating.
- The connectors must be roughly aligned using the alignment marks on the plug body, flange and receptacle cone.
- The mounting of the ROV handle has sufficient compliance to accommodate fine adjustments during the final approach prior to connector engagement.
- Ensure correct orientation of the alignment disc
- It is important that the ROV compliant flange is orientated correctly.
- Observe the text on the flange, and orientate accordingly.
- Please see images on page 20

IMAGES OF ALIGNMENT MARKS AND LIP SEAL MATING INDICATOR

Top View

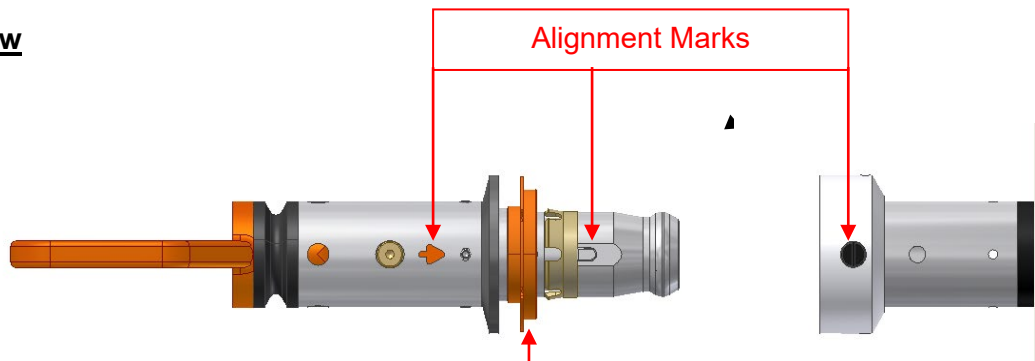

Side View

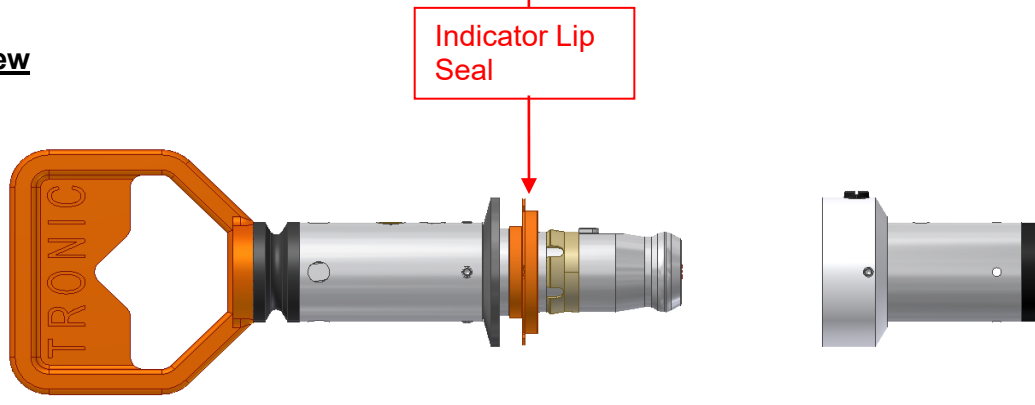

Fully Mated – Lip seal not visible



Figure 15. Images of alignment marks and Indicator Lip Seal

- **Mate/De-Mate Speed**

The connectors have been designed to operate across a wide range of mate / de-mate speeds with **POWER OFF**. There is no practical limit to the speed at which the connectors may be mated or de-mated, however as a guide: -

- a) Mating speed should not exceed 1 m/s.
 - b) De-mating speed should be 40mm/s to 60mm/s.
-
- When fully mated lip seal will not be visible and connection should look like as shown above.
 - If lip seal can still be seen remove and retry making connection by following the procedure again.
 - If connectors can't be mated both the plug and receptacle need to be inspected for any mis-alignment damage or debris that is preventing connection.
 - If any damage has occurred please record on information and notes/health and safety feedback at the rear of this document and inform Technical Department.

14.2 MECHANICAL FORCES DURING MATING / DE-MATING

The connectors have been designed to accommodate over stroking and bending forces to the following limits.

Over-stroking force < 2,205 lbf [9810N]

Bending < 370 ft-lbs. [500Nm]

Torsion < 370 ft-lbs. [500Nm]

14.3 MAXIMUM MISALIGNMENT VALUES

The values for maximum misalignment that the DigiTRON connectors can tolerate with mating still possible are as follows.

Misalignment Type	4/7-way	12-way
Rotational (0°)	±15°	±15°
Radial	±20mm	±20mm
Angular	±20°	±20°

14.4 POST MATING CHECKS (DIGITRON ROV ONLY):

During mating the orange Indicator Lip Seal located on the plug connector will fold back and disappear into the alignment cone on the receptacle connector. After a successful mating of the connectors no part of the indicator lip seal should protrude through the joint between the plug and receptacle connectors.

14.5 ROV MATING / DE-MATING FORCES (DIGITRON)

4 & 7 way Mating <30 Kgf
 De-mating 24 – 36 Kgf
 12 way Mating <50 Kgf
 De-mating 48 – 80 Kgf

14.6 MECHANICAL FORCES DURING MATING / DE-MATING:

The connectors have been designed to accommodate over stroking and bending forces to the following limits.

Over-stroking force < 2,205 lbf [9810N]

Bending < 370 ft-lbs. [500Nm]

Torsion < 370 ft-lbs. [500Nm] Mechanical over-loading from The ROV

- The maximum bending moment that can be applied to the connectors when mated is 2000Nm before the risk of mechanical damage to the electrical connection becomes significant.

14.7 DE-MATING

- De-mating is achieved by a straight pull on the ROV handle sufficient to release the latching mechanism.
- Force required is detailed under the mechanical forces section see section 14.5
- Ensure protective caps are fitted when not mated and while in storage
- If the connectors are to be left unmated, in seawater, for any length of time dummy connectors must be used to protect the pin contacts in the receptacle connectors. Over exposure will increase the risk of corrosion damage or marine growth on the contact surfaces of the receptacle contact pins. This could lead to damage to the seals and insulation within the socket contacts. Plug connectors do not require full dummy connectors for protection. Siemens advise the fitting of acetal caps to protect plugs.
- For topside use eg SIT, there is an ROV separation tool available. Part number BQ-30090-00.

NOTE: 28 DAYS IS THE MAXIMUM CUMMULATIVE ALLOWABLE EXPOSURE OF UNPROTECTED CONTACT PINS TO SEAWATER OVER THE LIFE OF THE CONNECTOR. THIS ONLY APPLIES WITH POWER OFF.

15. TEST CONNECTORS

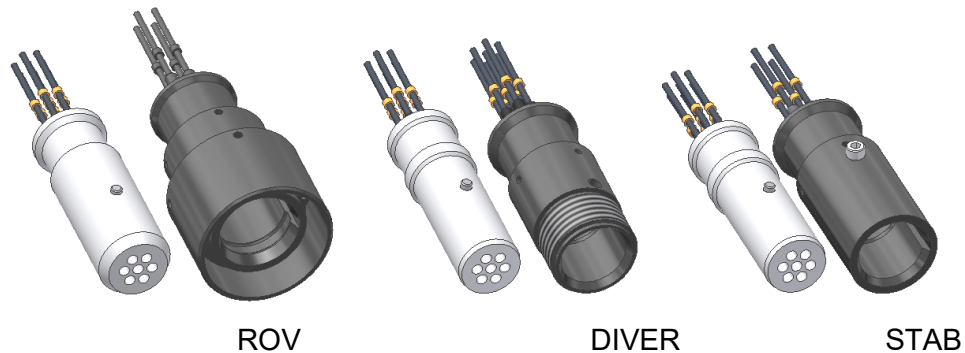

Figure 16.
Typical standard DigiTRON test connector

Installation of tails

Tails require soldering into the solder cups on the rear of the test connector. Siemens installation procedure to be used.

Only Siemens trained personnel are qualified to make these terminations.

Each termination will be protected by a termination sleeve supplied with the connector.

15.1 TESTING OF SINGLE CONNECTORS

- The appropriate test connector must always be used to make electrical contact during testing.
- **UNDER NO CIRCUMSTANCES** should a foreign object (such as a screwdriver, test probe, or crocodile clip) be used as a test connection as this could damage the seals and insulation.
- Such actions will invalidate the warranty of the connector.
- Guide pins must never be removed from test connectors as this can lead to damage and will invalidate the connector warranty.
- To perform any testing refers to specific project documentation for details of procedures.

NOTE: No part of the connectors should be dismantled prior to or during deployment, apart from the removal of protective caps, since there are no user serviceable parts inside.

16. DIGITRON CONNECTOR SPECIFICATION

Electrical and Mechanical

Maximum current (dry topside)

4-way = 18A

7-way = 14A

12-way = 11A

Maximum current (submerged)

4-way = 35-40A

7-way = 22-32A

12-way = 20-28A

- Maximum working voltage: 1000V rms phase to earth, 2000V rms phase to phase
- Rated number of operations: 1000 (750dry/250wet) mate / de-mate cycles (Power off)
- Working pressure: 5800 psi (13123 ft / 4000 metres water depth)
- Working temperature range: -5 to +60°C
- Onshore testing temperature range: -20°C to +50°C
- Storage temperature range: -40 to +70°C

Please note; maximum storage temperature takes into account solar gain. Skin temperature must not exceed 70°C. Suitable protection must be used to ensure maximum storage temperature is not exceeded.

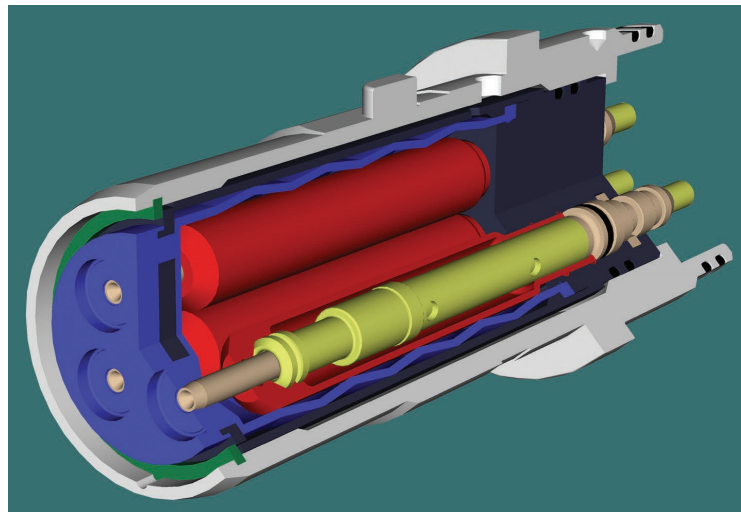

Figure 17.
View to show DigiTRON Front end assembly
(Fully factory acceptance tested)

17. MAINTENANCE

17.1 PROTECTION OF RECEPTACLE CONTACT PINS

Under no circumstances must the contact pins in the receptacle connector be exposed to seawater with power on. If this situation does occur the contact surfaces of the pins will very rapidly degrade by electrolytic action. If these damaged pins are subsequently mated into a socket insert there is a **very high risk** of damage to the insulation and seals within the plug connector.

17.2 OVER CURRENT CAPACITY

Over current capacity for all DigiTRON connectors is 100A for 5 seconds at no more than 2 per hour.

17.3 MARINE GROWTH AND CALCAREOUS DEPOSITS

To remove calcite growth from Siemens connectors, a solution of 50% Citric Acid is recommended. All Seawater exposed elastomeric materials in Siemens connectors have been fully tested against 50% Citric Acid and are compatible for duration of 1 hour. In addition, the thermoplastic materials have good resistance to Citric Acid.

Other acid cleaners, such as 50% Acetic Acid, should **not be** used as they may cause deterioration of the elastomeric materials. Chiseling and abrasive methods are not recommended. Use of a water jet is acceptable, but the jet should not be directed onto the shuttle pins at the front of the plug, or the pin contacts at the front of the receptacle, as this could result in a risk of water being forced through the primary seals.

Any damage found should be recorded and reported to the Technical Department.

18. INFORMATION AND NOTES / HEALTH & SAFETY FEEDBACK

DATE	DESCRIPTION

19. SIGN OFF SECTION

Please sign and date where indicated to confirm that each page of this document has been read and complied with in full.

Name	Signature	Date