

SIMATIC PCS 7 APC-Portfolio

SIEMENS

White Paper

How to Improve the Performance of your Plant Using the Appropriate Tools of SIMATIC PCS 7 APC-Portfolio?

October 2008

For many customers (facility operators, engineering companies, EPCs, system integrators) it is good news, that APC (advanced process control) functions are increasingly offered as embedded functions in distributed control systems, like for example by Siemens in the SIMATIC PCS 7 APC-Library and the Advanced Process Library. Looking at the large variety of different APC tools, there is a choice: which approach is appropriate for which type of task or process, in order to improve plant performance and achieve the maximum benefit with the minimal effort.

The following contribution starts with a survey of popular APC tools as offered in the PCS 7 APC-Library. Based on this, a typical procedure to improve process control using APC tools is outlined and illustrated by a case study.

Contents

1	Survey: APC Tools in the PCS 7 Libraries	3
1.1	Introduction	3
1.2	Control Performance Management.....	3
1.2.1	Control Performance Monitoring	3
1.2.2	Computer-aided Controller Optimization (PID-Tuning).....	5
1.3	Extensions to PID Control.....	5
1.3.1	Override Control	5
1.3.2	PID Gain-Scheduling	6
1.3.3	Smith Predictor Control for Deadtime Processes.....	7
1.3.4	Dynamic Disturbance Compensation (Lead-Lag Feedforward Control)	8
1.4	Multi-Variable Control (MPC: Model Predictive Control)	10
1.4.1	Intuitive Explanation of Predictive Control.....	11
1.4.2	DCS embedded MPC versus MPC with Online Optimization	12
1.4.3	Configuration of Predictive Controllers	13
2	Typical Procedure to Improve Plant Performance using APC Tools.....	14
2.1	Situation Analysis and Potential	15
2.1.1	Identification of Economic Targets for Process Control	15
2.1.2	Analysis of Current Plant Status incl. Control Performance Monitoring	16
2.1.3	Review of Basic Automation, Eventually PID-Tuning	16
2.2	Concept Definition of APC-Functions	16
2.2.1	Selection of Appropriate Approach Based on Analysis	16
2.2.2	Design of Control System Structure, Selection of MVs, CVs and Constraints	18
2.3	Configuration of APC-Functions	19
2.3.1	Process Excitation and Recording of Learning Data	19
2.3.2	Modelling.....	19
2.3.3	Controller Tuning	20
2.3.4	Commissioning	20
2.4	The Most Important Rules at a Glance	21
2.5	Documentation, Training and Maintenance.....	21
3	Case Study Distillation Column.....	21
3.1	Template-based Implementation	22
3.2	Economic Benefit	23
3.3	Summary.....	24
4	Literature.....	24

1 Survey: APC Tools in the PCS 7 Libraries

With the APC-Library of Simatic PCS 7 ([1.], [2.]), for the first time advanced process control functions are included in the scope of delivery of the distributed control system (DCS). Besides the core control algorithms, there are also the related process tag types and software tools for computer-aided controller configuration available without extra charge.

The APC functions can be divided in three classes:

- control performance management,
- extension to PID control, and
- multivariable control.

Fuzzy Control and artificial neural networks are also offered in the context of Simatic PCS 7 in the so called AddOn Catalogue [3.], but are not further detailed in this paper.

Due to the reduced costs of a system-embedded and template-based implementation, a large number of applications including small and medium sized processes become accessible for advanced process control – including processes where it is not affordable (in the context of desired amortization times) to interface expensive external advanced process control software packages to the DCS.

1.1 Introduction

In the following sections, each of the APC tools is explained by its main principle, typical use cases and typical applications (industry branches, process units). The short descriptions are intended as introductory reading and make no claim to be complete. Further information can be found in the literature cited and the relevant product documentation.

The PCS 7 example project 'Getting Started with Advanced Control' allows users to get familiar with the new advanced process control structures by doing hands-on experiments without having to intervene in the real process. This way, the concept, the requirements and the benefit of a certain APC structure can be realized before it is applied to a real process. For this the examples include process simulation and intuitive OS-pictures. For the extensions to PID control, the same process simulation is set up twice, one instance with APC extension and the other without - all other process and controller parameters identical. The advantages of the APC extension can be tested as a direct comparison.

1.2 Control Performance Management

The generic term control performance management includes control performance monitoring and optimization of control loops.

1.2.1 Control Performance Monitoring

Empirical studies have shown that many of the control loops in process industries do not fulfil their requirements properly and there is large potential for improvements. However not everybody is aware of this.

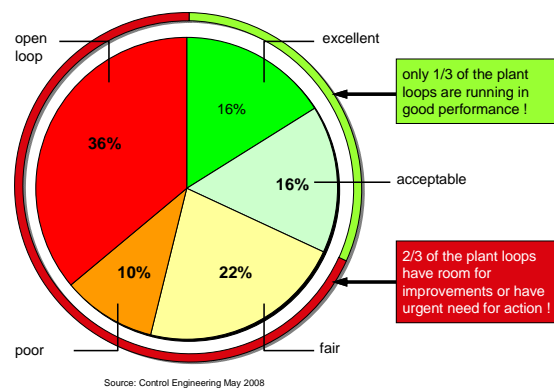

Figure 1: Potential for improvements in control performance, from [14.]

Plant operators or instrumentation and control technicians on their own do not have a chance to permanently supervise the huge numbers of control loops they are responsible for. Therefore functionality is needed to automatically monitor the control performance of all loops in a plant, and all the time, in order to schedule specific maintenance activities or selective controller re-tuning in a timely manner if the performance of single control loops is decreasing or troubles are developing. For monitoring in the sense of a non-invasive diagnostic, only the measurement data of regular process operation are evaluated. (Controller re-tuning however requires active plant experiments.)

Each control loop to be monitored is by default equipped with a dedicated performance monitoring function block (ConPerMon, [6.]), like designated in the process tag types of the Advanced Process Library [9.]. Using these process tag types, the engineering effort for manual linking of monitoring and controller function blocks can be reduced.

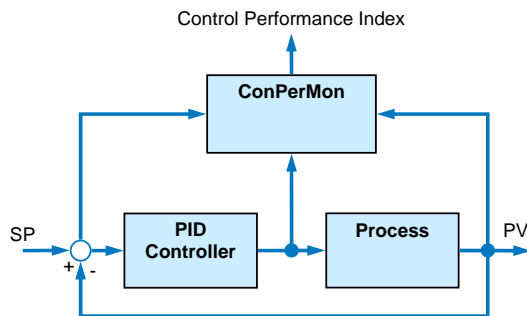

Figure 2: Signal flow for control performance monitoring, SP: Setpoint, PV: Process Value, MV: Manipulated Variable

In steady state process operation this monitoring function block calculates the following stochastic features of control performance:

- Mean value, variance and standard deviation of controlled variable,
- Mean value of the manipulated variable and control deviation,
- Control performance index,
- Estimated steady state process gain.

For setpoint steps, the following deterministic features of control performance are evaluated:

- Rise time, settling time and settling ratio,
- Overshoot absolute and relative to the step height.

Other statistical and graphic evaluations of the signals in the control loop over longer, freely selectable periods are available in the faceplate of the ConPerMon block.

In an overview representation of a plant or unit, you can obtain a clear picture of the status of all control loops using ConPerMon block icons (indicator light function). The aim is to detect problems as they develop and to focus the attention of the user on the control loops in a plant that are no longer operating correctly.

Application Examples

Control performance monitoring can be applied in any process and any industry. It provides a fast overview of problem loops and their deviation from ideal performance inside the DCS. Typical application areas are plants with huge numbers of control loops, as in the steel or paper industry, refineries, petrochemicals and bulk chemicals. Several conclusions with respect to the state of the corresponding loop can be drawn by interpretation of the indicators calculated by the monitoring block, without special prior knowledge:

- A mean steady-state control deviation $\neq 0$ at a constant setpoint is an indication of problems in the control loop if the controller has integral action. You should then check the following potential causes:
 - (1) The actuator does not have sufficient capacity. As a result, the controller's manipulated signal constantly approaches its limit. This can be caused by unsuitably dimensioned actuators, varying operating conditions or simply by wear and tear.
 - (2) The manipulated variable demanded by the controller does not have an impact on the process, for example because the actuator is defective.
- If the process gain (e.g. the intensity of heat or material exchange) changes gradually as time progresses, this is an indication of wear phenomena in the process, such as fouling of heat exchangers, valves or shutters, decreasing efficiency of process units, etc. If, for example, a temperature is regulated by a heat exchanger and fouling is developing on the exchanger surfaces, the heat transfer coefficient, and consequently the process gain, is reduced. Within certain limits, this can be compensated for by a closed control loop (so that the controller initially hides away the problem). Although the original control loop dynamics can be restored (to a certain extent) by suitable increase of the controller gain as the fouling increases, it is advisable to eliminate the cause of the problem; in other words, to clean the heat exchanger.
- The control performance index (CPI) in the unit [%] describes the current variance of the controlled variable relative to a reference variance (benchmark). It is defined as $\xi = \frac{\sigma_{ref}^2}{\sigma_y^2} 100\%$.
- The CPI moves in the $0 < \xi \leq 100\%$ range. If the current variance corresponds to the reference variance, the index reaches the value 100. Ideally, the reference variance is obtained in a defined good state of the control loop (e.g. after commissioning with a PID-Tuner) and stored when the ConPerMon block is initialized. If the current variance increases, the control performance index drops accordingly. If the performance index falls below a specified threshold, a message is generated, and the process picture symbol shows a colour change from green to yellow or red. Decreasing control performance means that controller tuning and process behaviour do not fit together any more. If the initial process behaviour cannot be restored, it is advisable to re-tune the controller.

- The relative overshoot as a percentage is a measure of the damping of the control loop. If relative overshoot is more than 20 or 30%, the loop gain (gain of the controller multiplied by the gain of the controlled process) is generally too high, either because the controller was badly tuned from the beginning or because the properties of the controlled process have changed over the course of time. If overshoot is significantly too high, the control loop is generating weakly damped oscillations in the plant. If overshoot is too high, it is often helpful to reduce the gain of the controller.

1.2.2 Computer-aided Controller Optimization (PID-Tuning)

Many PID-controllers in industry are tuned by trial-and-error methods or by heuristic rules, and the differential action is frequently not considered at all. For certain standard control loops like the flow control of fluids with a proportional valve, there are empirical values for standard parameter sets. For slow controlled processes like temperature control loops, an optimization by trial-and-error takes too much time, because the observation of a single step response may need several hours.

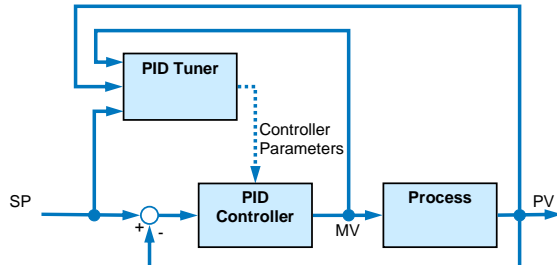

Figure 3: PID-Tuning (Computer aided control system design)

Consequently the application of computer-aided controller design tools is winning recognition. The calculation of optimal controller parameters is performed with an experimental procedure starting with the modelling of the process dynamics. The process is excited with a step of the manipulated variable or a setpoint step (if there is at least a stable but suboptimal controller setting). A dynamic process model is estimated from the stored measurement data by the tuning tool, i.e. the process parameters are calculated such that the learning data are fitted optimally (in a least squares sense) by the model.

In the approach of the PCS 7 PID-Tuner [8.], which is especially simple and robust and fully integrated into the DCS engineering software, an algorithm with PT_n-models of rising order is applied:

$$g(s) = \frac{k_S}{(t_1 s + 1)^n}$$

Only the three parameters process gain k_S , time constant t_1 and system order n have to be estimated by the PID-Tuner. The bigger the order n , the bigger is the time lag relative to the settling time of the step response.

The calculation of the optimal controller parameters according to the modulus optimum [5.] is based on the identified process model.

Moreover, the PCS7 PID-Tuner offers the possibility to choose between two different variants of controller design:

- Optimal disturbance compensation. (The trade-off are 10-20% overshoot for a setpoint step.)
- Optimal setpoint tracking without overshoot. This can be achieved by structure decomposition (P/D-action moved to feedback path) without losing in disturbance compensation only for low order plants, whereas controlled processes with order bigger than 2 require a gain reduction.

1.3 Extensions to PID Control

This generic term summarizes different solution approaches that can be realized by clever combination of PID controllers with other standard function blocks, and that are offered as process tag types in PCS 7 Advanced Process Library [9.].

In this area, there is no generally-accepted distinction, as to which of these structures are to be called "advanced" control. The following process tag types from [1.] are considered "conventional" control in this paper and therefore not further described here: cascade control, ratio control and split-range control.

1.3.1 Override Control

In override control, two or more controllers share a common actuator. Depending on the current process state, a decision is made as to which controller actually has access to the actuator; in other words, the various controllers can override each other.

A typical use case is a gas pipeline with pressure and flow control using a single valve. The main aim of the control is to achieve a certain flow rate, however due to safety considerations, the pressure must be kept within certain limits. The pressure controller is therefore known as the "limiting controller" or "secondary controller"

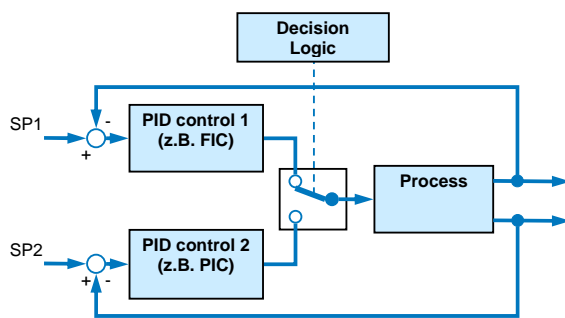

Figure 4: Override control

The logical decision as to which controller should be active can be made based on two different criteria resulting in two different types of override controls:

- The decision is based on a measurable process output variable, for example one of the two controlled variables. In the example above, the warning limits of the pressure controller can be used to decide whether the pressure controller should be active. The passive controller is in tracking mode to avoid Windup problems and to ensure bumpless transfer. The setpoint of the secondary controller must be somewhat lower than the switchover threshold so that the transfer can be reversed again. This type of override control is easy to understand and to implement. Its advantage is that the high and low limit of the secondary controlled variable (for example pressure) can be monitored; its disadvantage is that a limit cycle oscillation results as soon as the limiting controller needs to intervene. The secondary controller will always attempt to return its controlled variable to the safe range and to return command to the main controller (for example flow rate) so that the active and passive controllers swap over continuously. This variant is therefore only recommended when the secondary controller is seldom required and functions mainly as a safety or backup system.
- The decision is based on a comparison of the manipulated variables of both controllers, for example the controller that demands the higher (or lower) controlled variable takes control of the actuator. In the example above, the controller that wants to open the valve further takes over control. The setpoint of the secondary controller defines the switching threshold. Both controllers run the entire time in automatic mode. To avoid Windup problems, the manipulated variable limits must be tracked in a crossover structure: When the higher (lower) manipulated variable wins, the low (high) lim-

its of all controllers of the currently highest (lowest) manipulated variable must be corrected slightly up or down by, for example, 2% of the manipulated variable range. This means that this scheme can also be used in applications with more than two controlled variables. There is no Windup problem at the high limit because the highest manipulated variable takes over control anyway. This approach avoids the limit cycle oscillation of alternative 1 but is, in principle, asymmetrical. In other words, either a high or a low limit of the secondary controlled variable can be monitored but not both. This type of override control is described in most control textbooks, particularly in the USA. It can, however, only be used with PID algorithms that allow online manipulation of the MV limits (manipulated variable limits, in PCS 7 as of V6.0). Alternatively, in PID controllers based on an incremental PID algorithm, there is the possibility to overwrite the MV value of the last sampling step (that is stored inside the controller) by a linkable input variable called "external reset". Incremental PID algorithms are typically offered by US American DCS vendors and in PCS 7 APL as a special function block PIDConR [2.].

Further Application Examples

- Steam generator: The primary controlled variable is the steam pressure but the water level in the steam tank must be monitored so that the heating coils remain completely covered by water and the tank does not overflow. The only manipulated variable is the outlet valve.
- Compressor: The primary controlled variable is the throughput but the pressure must be monitored to make sure it does not exceed a safety limit. The only manipulated variable is the motor speed.
- Steam distribution system: Every plant involving industrial processes has a network of pipes to distribute steam at various pressures throughout the plant. The high pressure of the steam is reduced to lower levels via a valve. The primary controlled variable is the pressure at the lower-level stage, however the pressure in the high pressure piping must also be monitored to make sure that it does not exceed a safety limit.

1.3.2 PID Gain-Scheduling

Many processes have a non-linear response due to non-linear physical, chemical or thermodynamic effects. When such a process needs to be kept in the close vicinity of a fixed operating point, the transfer response can be linearized around this operating point. A linear PID controller can be designed for this linearized transfer function. If, how-

ever, the process has a strongly non-linear response and/or operates at different operating points, no constantly good control response can be expected throughout the entire operating range. Due to the non-linearity, various gain factors or process time constants are in effect at different operating points. In keeping with this, different controller parameters will be considered to be optimum

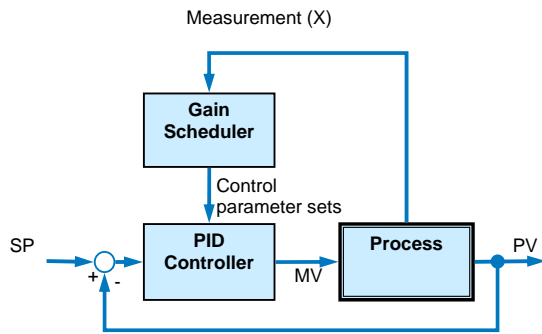

Figure 5: Gain scheduling

One possible (the simplest) solution to this problem is known as gain scheduling or parameter scheduling. Using a tool such as the PCS 7 PID Tuner, various experiments are performed at different operating points, in each case with low signal amplitudes. This results in different PID parameter sets for each operating point. Up to three such parameter sets can be stored in the gain scheduling function block (GainSched). The suitable parameter set is selected depending on a continuously measurable variable (measurement X in Figure 5) that describes the state of the process, typically the control variable PV itself. Between the operating points for which there are exact parameter values, the values are calculated by linear interpolation of the neighbouring interpolation points so that soft and bumpless transitions are possible between the operating points. The term "parameter scheduling" makes it clear that the "timetable" for adjusting the parameters is specified in advance. In contrast, an adaptive controller adapts itself automatically to the differing process response during operation.

The function block GainSched is produced from the CFC chart "fbGainSched" by compiling it as a block type. This CFC chart is supplied with the library [1.] so that the user has the option of expanding the existing basic functionality as necessary, for example to more than three operating points, or application specific logic for selection of parameter sets.

Note: The combination of several locally optimized controllers by gain scheduling to form a non-linear controller does not necessarily represent an optimum non-linear controller for the non-linear process when considered from a mathematical point of

view. This becomes clear even with benign non-linearities (that are continuous and can be differentiated) when setpoint step changes are made between different operating points. With non-linearities that are discontinuous or cannot be differentiated or with non-monotonic non-linearities, great caution is needed.

Application Examples

- Control (especially temperature control) of batch processes, for example, batch reactors and batch columns
- pH value control by dosing acid or base (nonlinear titration curve)
- Temperature control with phase transitions (for example, fluid/vapour)
- Control of semi-batch plants (continuous plants with operating point changes, for example, polymerization reactors)
- Control in power plants with load changes

1.3.3 Smith Predictor Control for Dead-time Processes

A deadtime can be recognized from the observation, that after intrusion of an MV move, there is no reaction of the controlled variable at all for a certain time (the deadtime). In processes with large dead times θ (e.g. $\theta > 0.25 t_1$ relative to the dominating lag time constant t_1), a standard PI controller must be tuned very slowly and compromises must therefore be accepted in the control performance. The control performance can be significantly improved with a Smith predictor that can be derived from the IMC principle (Internal Model Control) of model-based control.

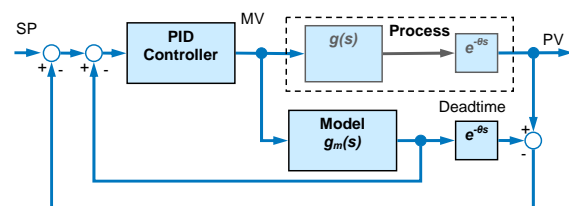

Figure 6: Smith predictor

To achieve this, the transfer function $g_s(s) = g(s)e^{-\theta s}$ of the controlled system is split up into a part $g(s)$ without dead time and a purely dead time part $e^{-\theta s}$ with dead time θ . Only the controlled variable (PV) affected by dead time can be measured in the real process. However, a virtual estimate of the controlled variable free of dead time can be taken from the process model (that will

become part of the controller) and fed to the controller. This means that the controller itself can be designed for the process without a dead time and can therefore be tuned much more tightly. To compensate for unknown disturbances, an estimate of the controlled variable affected by dead time is made in the model and compared with the genuine measured controlled variable. This difference is also fed back to the controller.

In terms of practical application, it must be pointed out that the performance of the Smith predictor depends largely on the model fit; in other words, the dead time must be known. The dead time must be constant or its value must be permanently adapted.

Note: For processes with large dead times, a model predictive controller (c.f. section 1.4) is also suitable in a single-input single-output situation. It provides greater flexibility in system modelling and is more convenient thanks to the integrated design tool. However, it does require more CPU resources, and does not allow online adaptation of the dead-time value.

Application Examples

The typical cause for deadtimes in process engineering plants are run durations of fluids or gases in pipes, or run durations of bulk solids on conveyor belts.

- Temperature control via feeding of hot steam or cold/warm water in a chemical reactor jacket. After opening the valve, it takes some time until the tempered medium reaches the jacket via the pipe.
- Temperature control in chemical reactors or distillation columns via external heat exchangers. After an MV move at the heat exchanger it takes some time until the tempered medium flows back from the heat exchanger to the reactor or column via the pipe.
- Load control on a conveyor belt: the spatial distance between MV intervention and measurement system can be converted directly into a deadtime via the conveyor speed.

1.3.4 Dynamic Disturbance Compensation (Lead-Lag Feedforward Control)

Feedforward disturbance control can be used when a known, strong disturbance affects the process and its cause can be measured. In these cases, the following general strategy applies: "Feedforward control as much as possible (as much as known in advance and described by a model), feedback control as much as necessary (the rest including the model error and immeasurable disturbances)".

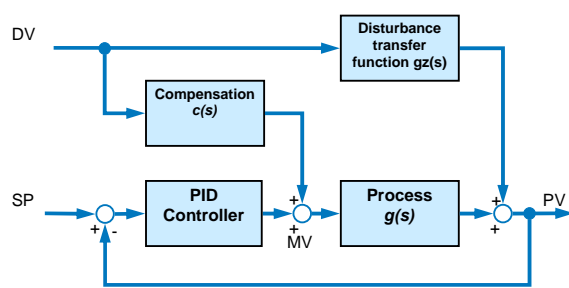

Figure 7: Feedforward disturbance compensation, DV: Disturbance Variable

The impact of a measurable disturbance can be estimated in the form of a transfer function

$$g_z(s) = \frac{y(s)}{z(s)} \quad (\text{with } y: \text{CV and } z: \text{DV})$$

when the controller is running in manual mode so that no changes whatsoever to the controlled variable $y = PV$ are caused by the manipulated variable and all changes can be attributed to the disturbance $z(s)$.

The transfer function of an ideal feedforward control $c(s)$ can be derived from the requirement that the impact of z on the controlled variable y should be zero for any disturbance signal $z(s)$

$$g_z(s)z - c(s)g(s)z = (g_z(s) - c(s)g(s))z = 0$$

To meet this equation, the compensation block must approximate the equation

$$c(s) = \frac{g_z(s)}{g(s)}$$

as well as possible. For this to happen, the disturbance transfer function must be known and the transfer function of the main controlled system

$$g(s) = \frac{y(s)}{u(s)} \quad (\text{with } u: \text{MV})$$

must be inverted. If both transfer functions can be modelled as first order plus dead time $g(s) = \frac{k_S}{1+t_1s} e^{-s\theta}$ and

$$g_z(s) = \frac{k_{Sz}}{1+t_{1z}s} e^{-s\theta_z}, \text{ and } \theta < \theta_z \text{ applies, the resulting compensation element must represent the lead-lag transfer function}$$

$$c(s) = \frac{k_{Sz}}{k_S} \frac{1+t_1s}{1+t_{1z}s} e^{-s(\theta_z-\theta)} = k_c \frac{1+t_d s}{1+t_s} e^{-s\theta_c}$$

This transfer function can be created outside the controller with a combination of elementary function blocks.

An additional input at the PID controller block allows adding this signal to the MV value. It is important that the addition of sideline contributions to the MV value is performed before the MV limitation of the controller block, in order to ensure proper limitation of the overall MV (including anti-windup).

However for general transfer functions $g(s)$ and $g_z(s)$ there will be more complicated or even unfeasible compensation functions. Those have to be simplified by order reduction, which might reduce the efficiency of disturbance compensation. This simplification can go that far, that the process dynamics is completely neglected, and only

$c(s) = \frac{k_{sz}}{k_s}$ is implemented (static feedforward control).

Application Examples

- Temperature control of an industrial oven: at the oven inlet, the disturbance variable feed flow is measured and fed-forward to the output of the temperature controller. The impact of varying flows on the oven temperature is anticipated and compensated for by modifying the heating power.
- Controlling the outlet temperature of a heat exchanger via steam pressure or heating/cooling medium flow: flow and inlet tem-

perature of the medium are the measurable disturbance variables.

- Fill level control in a drum steam generator using the inlet volume: the outflow is the measurable disturbance variable that is determined by the variable steam consumption in the plant.
- Temperature control in a distillation column using the reflux ratio or heating steam flow: the measurable disturbance variable is the mixture feed flow.
- Temperature and concentration control in an agitated tank reactor using cooling medium flow and discharge volume: the temperature and possibly also the concentration of the inflow are measurable disturbance variables.

Note: Dynamic disturbance compensation can also be realized with a model predictive controller (c.f. section 1.4), in multi-input multi-output and in single-output constellations. It provides greater flexibility in system modelling and is more convenient thanks to the integrated design tool. However, it does require more CPU resources.

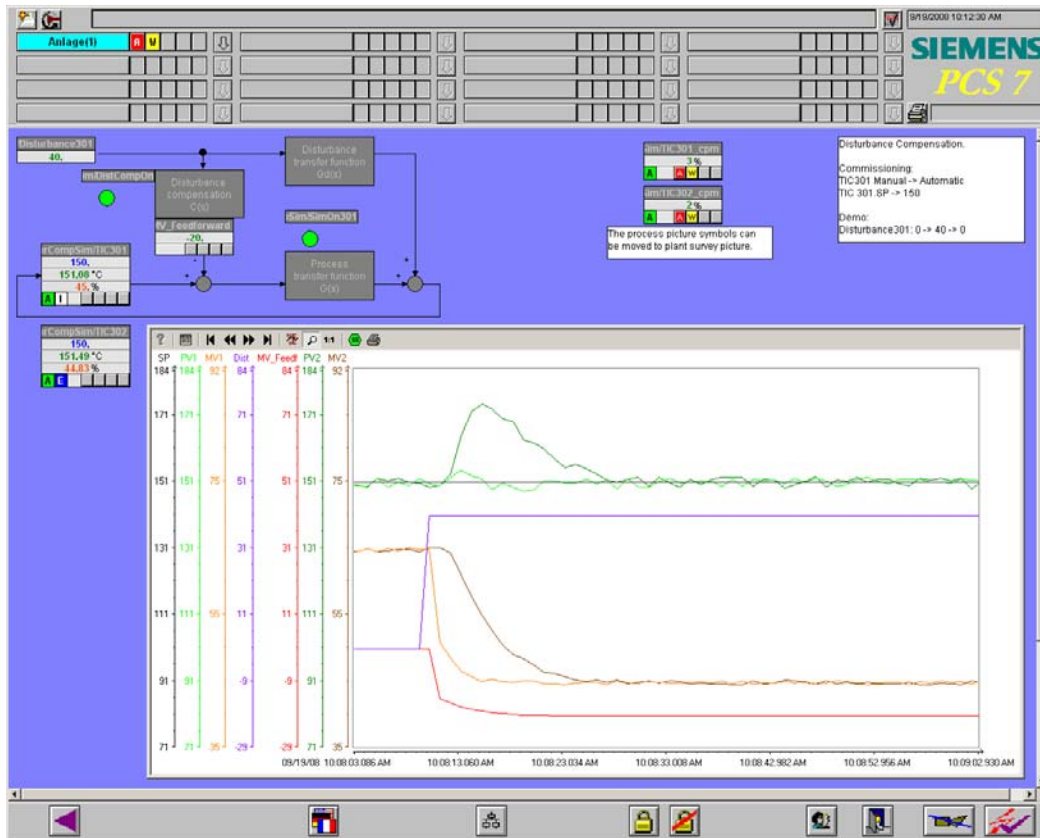

Figure 8: Benchmarking template for disturbance compensation, taken from example project of PCS7 APC Library. Black: set-point, green: controlled variables, orange: manipulated variables, light colours: with disturbance compensation, dark colours: without compensation, purple: disturbance variable.

1.4 Multi-Variable Control (MPC: Model Predictive Control)

If there are several manipulated and controlled variables (MVs and CVs) in one unit, that are interacting with each other, you are dealing with a multivariable control situation (MIMO control: multi-input multi-output, as opposed to SISO control: single-input single-output). The impact of each MV to each CV is described by a part transfer function.

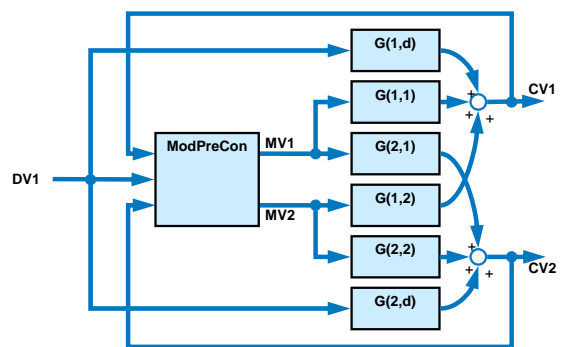

Figure 9: Multivariable control. CV: Controlled Variable, MV: Manipulated Variable, DV: Disturbance Variable. Each part transfer function $G(i,j)$ describes the impact of MV j to CV i . The figure shows a 2x2 process, but there can be more MVs and CVs.

The aim of any control system is to bring each controlled variable to its individual setpoint, independent of the other CVs. This is difficult because a move of one MV (e.g. MV1) does not affect only the related CV (e.g. CV1), via the main transfer function (e.g. $G(1,1)$), but also many or all other CVs, via the interaction transfer functions (e.g. $G(i,1)$).

If the impact of the interactions ($G(2,1)$ and $G(1,2)$ in the example) is weak compared to the main transfer functions ($G(1,1)$ and $G(2,2)$ in the example), it might be possible to solve the multivariable problem with two separate PID controllers (so called decentralized control). In some cases, single interactions can be compensated using lead-lag feedforward control (c.f. section 1.3.4). If however the impact of the interactions is too strong (large gains, small time lags), or there are more than two or three interacting variables, a real MIMO controller is necessary.

The main principle of disturbance compensation can be transferred from the SISO to the MIMO case, and an MPC algorithm even facilitates the implementation. A model of the influence of the disturbance variable to each CV is considered for prediction of the CVs, such that the controller can act in an anticipatory way against these disturbance impacts.

Although there are a lot of different MIMO control algorithms in theory, the model predictive controllers dominate the field in industry.

Application Examples

- Quality control in distillation columns, see separate chapter 3.
- Temperature control of several adjacent zones of furnaces with several burners, for example, tunnel furnaces, glass melting plants, glass feeders etc.
- Quality control in chemical reactors by adjustment of reaction conditions such as pressure, temperature, feed/drain etc..
- Vaporizers - for example drum steam generators.
- Mills - for example cement mills, sieve mills: quality control (grain size) in combination with flow rate maximization, manipulated variables: sieve speed and mill feed.
- Lime kiln (pulp mill): temperature control at hot end, cold end and hood draft; oxygen concentration control, via combustion gas feed, lime mud feed and fan speed.

1.4.1 Intuitive Explanation of Predictive Control

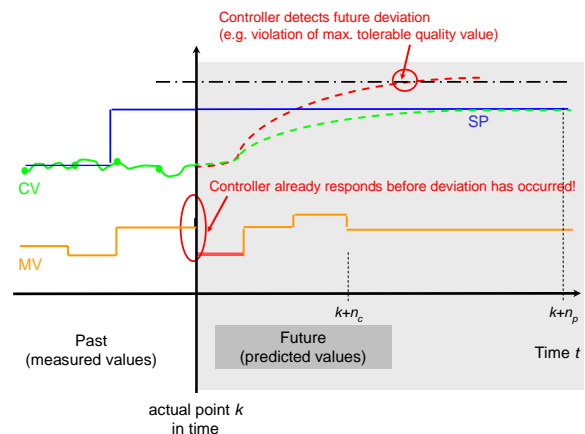

Figure 10: Explanation of predictive control. Red: future without control, green: future with control (planned optimal trajectory), n_c : control horizon, n_p : prediction horizon

The controller observes and stores the process movements of the past. The controller can predict the future movements of the CVs in a certain time horizon ("prediction horizon") using the internal complete dynamic process model including all interactions. The "future without control" assumes that all MVs are kept constant at their actual value. The impacts of measurable disturbance variables are already considered in the future without control.

Moreover, the controller can 'test' (simulate) what will be the future impact of different strategies to manipulate the process using the available MVs (inside the control horizon). An optimization algorithm is applied to find the best MV strategy and the planned optimal trajectory is displayed as 'future with control'.

The approach is similar to a chess computer: different combinations of future moves are 'virtually played' and evaluated according to their effects.

There are a lot of degrees of freedom in the formulation of the optimization setup: future control deviation, CV constraints and future MV moves are included in the performance index while MV limitations are hard constraints. Economic targets can also be considered in the performance index.

The optimization problem is solved for the whole prediction horizon online at each sampling step but only the first element of the calculated series of MV moves is applied to the process. At the next sample, the time horizon is shifted and the

complete optimization is re-started ('moving horizon principle').

In other words: the control problem is formulated as an optimization problem and solved as an optimization problem. The typical performance index looks like:

$$J = (\bar{w} - \bar{y})^T R(\bar{w} - \bar{y}) + \Delta \bar{u}^T Q \Delta \bar{u} \rightarrow \min.$$

w contains the time series of future setpoints,

y contains the time series of future CVs (inside the prediction horizon),

Δu contains the time series of future MV moves (inside the control horizon).

If the weightings in the Q diagonal matrix are increased, the controller moves its manipulated variables more cautiously resulting in a slower but more robust control action. Using the weighting factors in the R diagonal matrix, the relative significance of the individual controlled variables can be specified. A higher weighting (priority) for a controlled variable means that this one moves more quickly towards the setpoint and remains more accurately at the setpoint in steady state if it is not possible to achieve all setpoints precisely.

1.4.2 DCS embedded MPC versus MPC with Online Optimization

There are two completely different approaches to solve the MPC optimization task, resulting in two different classes of MPC algorithms:

(1) MPC with online optimization: If the optimization problem is to be solved with respect to constraints, a numeric iterative search for the optimum is necessary at each sampling step. Obviously, such an online optimization needs a lot of computing power. Therefore such types of MPC cannot be implemented in the controllers of a DCS, but need a separate PC interfaced to the DCS. Typically, an MPC is not manipulating the process directly but is commanding setpoints for subordinate PID controllers, i.e. the MPC performs the coordination of several PID controllers in the basic automation level, in the sense of "supervisory control".

Typical examples of such full blown MPC-software packages are e.g. DMC+ by AspenTech, Inca by Ipcos [3.], ProfitController by Honeywell.

(2) "Lean" MPC: If the constraints are not considered during optimization, an analytical solution of the optimization problem is possible, resulting in a straight-forward formula.

This formula can be posted offline using performance index and process model. For the online calculation of the MVs, there are only some matrix multiplications to be performed (no iterative search). This requires much less computing power than a full blown MPC. (MV constraints are fulfilled by the online-controller anyway.) Such simplified predictive control algorithms without online-optimization (lean MPC, embedded MPC) and with a limited number of MVs and CVs can be implemented as a function block on DCS controllers.

Example: The MPC function block from [1.] and the ModPreCon function block from [2.] can cope with up to four interacting MVs and CVs. Such an embedded MPC has the following advantages:

- The **availability** of the MPC function block is similar to a conventional PID controller. Backup strategies and arrangements for supervision of communication to external PCs are not necessary. All options of redundant DCS hardware can be fully exploited, increasing the availability of APC functions.
- The MPC function block can be connected to other function blocks in the **engineering** system like any PID controller, using predefined process tag types (templates for continuous function charts).
- For **operator control** of the MPC function block there are standard faceplates.
- **Look&Feel** is similar to a conventional PID controller and so familiar to plant operators, reducing training effort. External consultants as experts for special MPC software packages are no longer needed.
- Summing up, the **starting prize** for a turnkey solution is reduced by an order of magnitude. This also means that small and medium - sized applications become attractive for APC that does not allow amortizing a full-blown MPC.

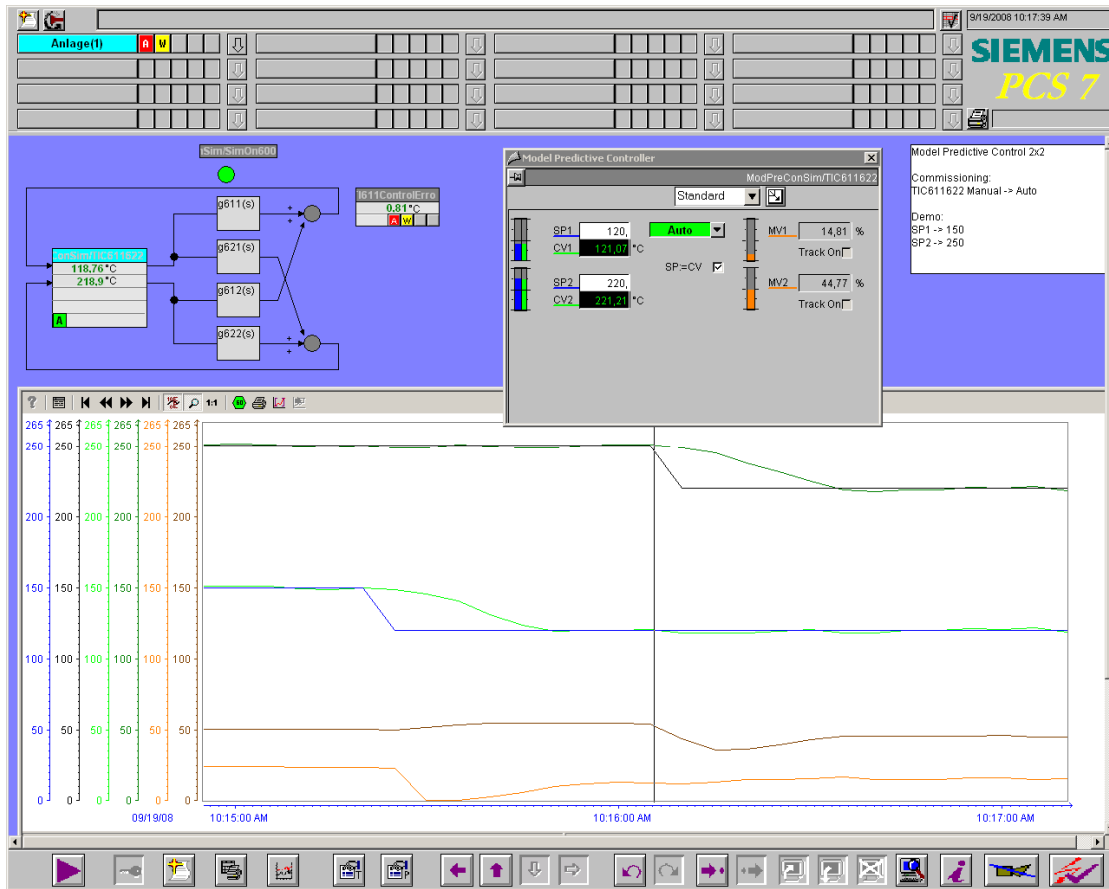

Figure 11: Embedded MPC on a PCS7 Operator Station

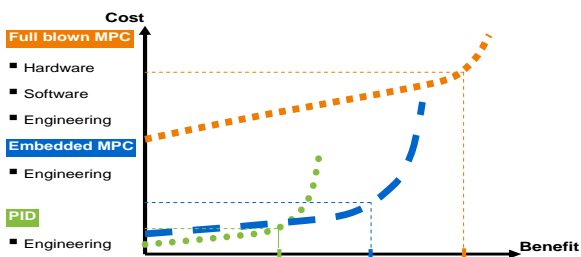

Figure 12: Cost benefit analysis of APC tools. For PID (incl. extensions) and embedded MPC, there are only engineering costs, while full blown MPC additionally needs hardware and software expenditure.

In some cases, an MPC function block is also helpful for a SISO process with particularly difficult dynamics. For processes with non-minimum phase or strongly oscillating responses or with very long deadtimes, it is better than PID control.

Most MPC algorithms only work for stable processes with a step response that settles to a fixed value in a finite time. If the process is unstable or includes an integrator (tank level control for

example), the corresponding partial transfer function must be stabilized with a secondary controller. For integrating processes, a simple P controller (proportional component only) is adequate as a secondary controller.

1.4.3 Configuration of Predictive Controllers

At the core of any predictive controller there is a dynamic process model that describes the behaviour of the real process, i.e. the correlation between all input and output variables, considering all time lags. This model is typically identified from learning data, i.e. the main approach is similar to PID-Tuning (c.f. respective section 1.2.2):

- Excite the process with MV moves in manual mode of the controller, store learning data (using the CFC trend recorder for the PCS 7 MPC Configurator).
- Identify process model: load data into MPC Configurator, select time span, filter noise if necessary. The identification itself is started by a mouse-click, resulting in a fourth-order plus dead time model for each part transfer

function. In case of 4 MVs and 4 CVs, this makes 16 part transfer functions.

- Verify model, i.e. simulate model with data different from the learning data.

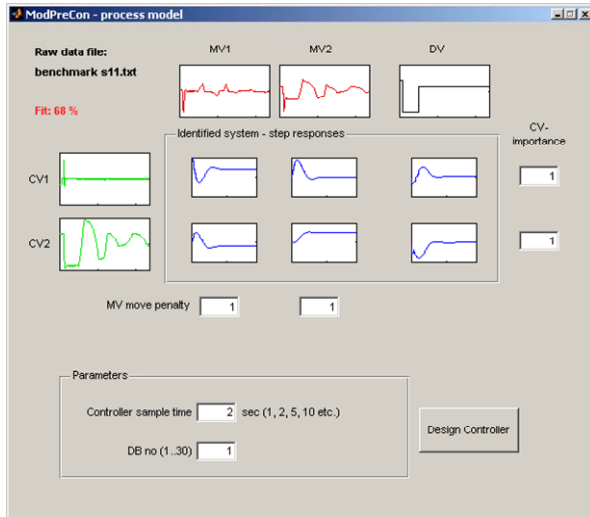

Figure 13: MPC Configurator in Simatic PCS 7

The configurator automatically proposes a reasonable controller sample time. During controller design, the user can enter the following specifications for the performance index:

- Different weightings for different CVs, with respect to their priorities in the specific application. Example: process safety is more important than product quality, product quality is more important than resource savings.
- Different MV move penalties for different MVs. By increasing an MV move penalty, this MV will move more slowly, and the related process actuators will be treated with care.

Before an MPC is applied to a real plant, it is recommended to simulate the closed loop response using the process model identified.

2 Typical Procedure to Improve Plant Performance using APC Tools

For the improvement of plant performance using APC tools, a typical procedure with several steps is established.

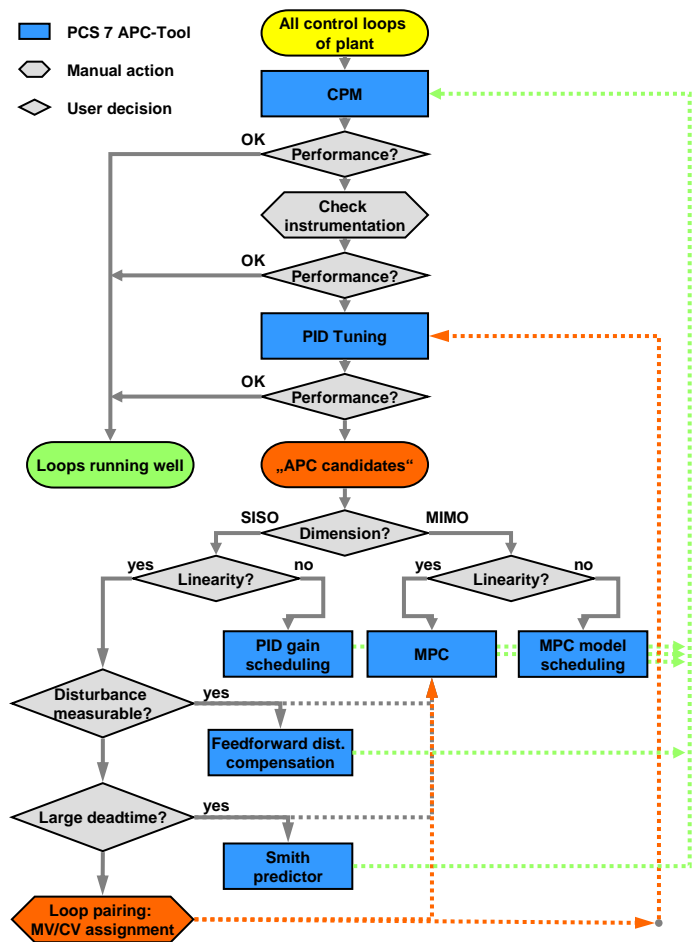

Figure 14: Typical procedure for selection of APC solutions. Blue shading refers to PCS 7 APC tools.

This description however has to be considered as a rough framework: during individual applications some steps can be skipped because prior knowledge is available, or some intermediate steps or iterations are required.

Some extensions to PID control like override control, cascade control, ratio control or split-range control are of structural nature: they are not visible in Figure 14, but they are applied if the respective structure is found in the setting of the task.

If all trials in the SISO case fail, the allocation of MVs and CVs has to be checked, or actually there is a need for MIMO control (orange arrow). After successful commissioning, APC functions as well as conventional control loops should be subject to control performance monitoring (green arrow).

2.1 Situation Analysis and Potential Estimation

2.1.1 Identification of Economic Targets for Process Control

The starting points for any discussion are economic considerations and the requirements for process control imposed by chemical engineering: Which measurable variables are relevant for the economic success of process operation? Which of them are relevant for plant safety, for

product quality, for production costs (consumption of raw materials and energy)? Which requirements for process automation are imposed by chemical engineering (e.g. recipes for chemical reactions), in order to ensure optimal production conditions? Which benefit could be achieved by improved control performance?

Table 1 summarizes the typical objectives for APC solutions in (predominantly continuously operated) process plants (following [4.], p. 201).

Table 1: Objectives for APC solutions

Objectives	Aspects
Productivity and Profitability	<ul style="list-style-type: none"> Increase throughput Minimize energy consumption Reduce changeover times, e.g. for changes of operation mode, raw material or target products (grade changes) Increase yield Reduce processing time
Quality	<ul style="list-style-type: none"> Increase repeatability; make process operation more steady and smooth Minimize variance of quality parameters Reduce effort for chemical analyses Reduce production of giveaway or inferior qualities
Operability and Availability	<ul style="list-style-type: none"> Increase tolerance against fluctuations in raw material Reduce sensitivity to disturbances Increase plant uptime Avoid plant shutdowns and reduce shutdown times Increase plant availability, flexibility and robustness
Operator Control	<ul style="list-style-type: none"> Cope with change of operators/shifts Reduce operator workload Increase operating comfort
Safety	<ul style="list-style-type: none"> Increase occupational health and safety Increase process and operational safety
Ecology	<ul style="list-style-type: none"> Minimize environmental impact, pollution and wastage Minimize emissions Save effluents and sewage

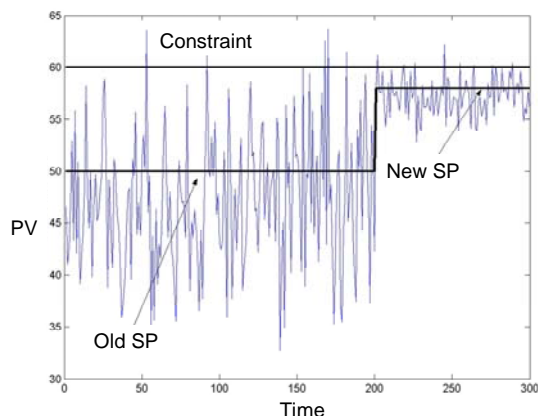

Figure 15: “Constraint pushing” – make the most of the economic potential of a plant by improved process control with reduced CV variance: move setpoints closer to CV constraints.

In many cases, such economic objectives are reached in two steps:

1. Reduction of CV variances by improved process control.
2. The reduced variances allow moving the setpoints closer to critical constraints without the risk of frequently violating the constraints. This is called “constraint pushing”: make the most of the process by using the full physical capabilities of the plant e.g. to maximize throughput or minimize energy consumption.

2.1.2 Analysis of Current Plant Status incl. Control Performance Monitoring

A thorough analysis of the current status of the plant is required before starting to think about APC. The status of instrumentation (sensors, actuators) and automation (especially the existing basic control loops e.g. PID controllers) should be checked. If a control performance monitoring system (cf. section 1.2.1) is established, typical problem areas can be easily found, e.g. loops that cause a lot of alarms; loops that are frequently running in manual; loops that show extremely high CV variances or are permanently oscillating.

2.1.3 Review of Basic Automation then PID-Tuning

Errors in Instrumentation found during the analysis must first be corrected, e.g. bad calibration of sensors; excessive friction of valves; leakages in compressed air pipes etc. Afterwards it must be ensured that all PID controllers are

tuned as well as possible, for example by application of a **PID-Tuning-Tool** (cf. section 1.2.2). This is the way to avoid ‘breaking a butterfly on a wheel’ – if a control problem can be solved by simple means, there is no need to go for elaborate APC methods.

In the framework of an APC concept, supervisory controllers, like multivariable MPC, are typically established as master controllers for many PID slave controllers. This is a cascade structure and in cascade structures it is important to avoid modifications of the tuning of slave controllers after the tuning of the master controller is finished because the slave closed loops are part of the (time-invariant) process model used in the master controller. This is one more reason to finish the optimization of the basic PID control loops before the implementation of supervisory APC functions and is in line with the general procedure for commissioning of cascade control structures ‘starting from inside loop, proceeding with outside loop’ i.e. **first the slave controller, then the master controller**.

2.2 Concept Definition of APC-Functions

The most important questions to be answered in the context of an APC concept are:

- Which are the objectives of the APC solution?
- Which MVs and CVs are available for the APC solution?
- Which algorithms are to be used?
- How to design the structure of the control system?

2.2.1 Selection of Appropriate Approach Based on Analysis

The basic questions with respect to selection of the appropriate approach are: SISO or MIMO control? Linear or nonlinear control?

2.2.1.1 SISO or MIMO Control?

With the background of the respective section 1.4 a checklist for the decision SISO or MIMO control could be the following:

- Does the plant unit (e.g. apparatus, machine, plant section) contain several CVs?
- Are there significant interactions between different control loops? Test: If a setpoint step is commanded for one loop, are there side-effects in other control loops? Any problems in tuning single loops, because modified control parameter sets in one loop have impacts on other control loops?

- Are the variables having an impact on neighbouring loops really moving during plant operation? Counter-example: the correlation between pressure and temperature of a gas volume in a reactor or vessel can be neglected if either pressure or temperature is kept constant during plant operation.
- Is the control performance of the CVs suffering from interactions really relevant for the economic success of plant operation? Counter-example: although there is a physical correlation between the feed flow into a vessel and the fluid level inside the vessel, in many cases it is sufficient for level control to manipulate the outflow valve because very precise level control is not required from a chemical engineering point of view.
- Any attempts failed in the past to solve interaction problems using lead-lag feedforward control (cf. section 1.3.4)? Spent excessive effort for design and engineering of decoupling structures in similar plant units?

If in doubt, a MIMO process model can be identified by the MPC Configurator. In the matrix of transfer functions, the step response of the interactions can be observed and compared to the main transfer functions on the matrix diagonal.

Tips for the decision to apply smith-predictor or lead-lag feedforward and the discrimination with respect to a SISO MPC can be found in the respective sections 1.3.3 and 1.3.4.

2.2.1.2 Linear or Nonlinear Control?

Most process plants are nonlinear by nature (physics, chemistry), i.e. the impact of a certain MV move is different depending on the actual operating point of the process. Typical causes are nonlinear valve characteristics; nonlinear reaction kinetics; phase transitions (solid/fluid/gaseous); titration characteristics etc. To decide on a linear or nonlinear control concept, the following questions are relevant:

- Is an existing linear control concept (e.g. conventional PID control) working well at a certain operating point, but oscillating or very sluggish at different operating points (e.g. after load change)?
- Does the operation of a process plant require frequent changeovers of operating point, e.g. in the context of batch recipes; in the context of grade changes (multi-product plant); in the context of a flexible production (load changes)? Counter-example: a linear controller can cope even with a strongly nonlinear process if a continuous plant is running always at the same constant operating point.

If one of the issues mentioned above require a nonlinear control concept, there are the following solutions possible that can be examined in the following order:

2.2.1.2.1 Compensation Functions in-between Controller and Process

Example: The effect of a nonlinear valve signature can be compensated by a polygon function block between the MV output of the controller block and the input of the valve block. In this case, the transformation of the MV limits must be considered.

In a similar way, the effect of nonlinearity at the process output (e.g. sensor characteristic) can be compensated for by a polygon function block in front of the CV input of the controller. In this case the related setpoint must be transformed in the same way.

In both cases, the compensation functions become part of the controlled process from the perspective of the controller. The aim is always to make the overall response of the controlled system (consisting of process and compensation elements) as linear as possible.

2.2.1.2.2 Operating-Point-Specific Parameter Sets

For SISO case: PID gain scheduling according to section 1.3.2.

For MIMO case: MPC multi-model control, cf. example project in PCS 7 Advanced Process Library. This approach is related to the basic idea of operating-point-based parameter control with PID controllers. Since the model parameters of the ModPreCon block cannot be modified at runtime, the schedule for selecting the suitable parameter sets becomes a schedule for selecting the suitable models.

Several ModPreCon instances with different models for different operating points run at the same time in parallel. The local optimal models are determined by exciting the process at the various operating points with small amplitudes, so that only the reaction of the nonlinear process in the ambience of this operating point is registered.

The final manipulated value for each manipulated variable is formed as a weighted mean value of the manipulated variables proposed by the different controller instances. The weighting factors 0 ... 1 are formed in the same way as the membership functions known from fuzzy logic so that the sum of all weights is always one and

each controller has the highest weighting at its own operating point.

2.2.1.2.3 Trajectory Control

This approach proposed by [11.] neatly combines the advantages of an open loop controller (feedforward control) with those of a closed loop controller (using process value feedback). The controller follows a previously optimized trajectory of setpoints and manipulated variables; in other words, it only needs to compensate small deviations between the stored trajectory and the current plant state. A trajectory is an optimum series of manipulated variables over time and the process values that match them. The required manipulated variables are read into the ModPreCon block via the inputs MV1Traj to MV4Traj and added to the values of the manipulated variable calculated by the algorithm (in automatic mode only). Among other things, the advantage of this is that the effective manipulated variable acting on the process (the sum of trajectory and controller action) is limited as configured in the controller block. The process values from the trajectory are linked to the corresponding setpoint inputs SP1 to SP4 of the controller. As long as the process reacts exactly as planned in the trajectory, it will respond to the series of MV values from the trajectory with the corresponding series of CV values and the control deviation is zero. It is generally known that a non-linear dynamic process can be linearized around a fixed operating point or a steady state of the system but it is also possible to linearize it around a trajectory.

2.2.2 Design of Control System Structure, Selection of MVs, CVs and Constraints

For SISO controllers, a one-to-one assignment of MVs and CVs must be specified: for each controller it must be decided which MV is used to manipulate a certain CV. If several MVs are in question, select the MV that has the strongest impact on the CV (in the sense of gain) and the most direct impact (in the sense of small time lag)

For an MPC concept, such an assignment is not necessary because the MPC makes use of all MVs to manipulate all CVs. For selection of MVs and CVs in a multivariable control system, the following issues are to be considered:

- Which CVs are interesting in the sense of the arguments of section 2.2.1.1? Which CVs are relevant for plant safety, product quality and economics? Which requirements for control precision are imposed by chemical engineering? Avoid inflating the problem more than necessary because the complexity of the

multivariable control problem increases quadratically with the number of MVs and CVs ('Divide and conquer!').

- The quality of measurements is also relevant for the selection of CVs: are the measurements reproducible, available in real time and low in noise?
- Which MVs are selected because they have a significant and direct impact on the designated CVs? Normally, it is recommended to search for as many MVs as there are CVs to cope with, resulting in a 'quadratic system'. The controller can then bring all CVs exactly to their target values as far as allowed by constraints. Otherwise you have constituted a...
- non-quadratic control problem (number of MVs is not equal to number of CVs). If there are less MVs than CVs, or some of the MVs have reached their limits, there is a lack of degrees of freedom, and it is no longer possible to reach all setpoints exactly. The MPC algorithm then finds a compromise that can be influenced by the selection of CV weights (priorities) in the MPC Configurator and CV zones in the MPC function block: CVs with higher priority will have lower control deviations with respect to their setpoints or zones. If there are more MVs than CVs or if some of the CVs are already within their control zones, there is surplus freedom in the control problem. A lean predictive controller algorithm (cf. respective section 1.4.2) however, cannot recognize this situation explicitly and use the free manipulated variables for optimization. The MPC block therefore moves all manipulated variables to values that meet the targets in terms of controlled variables and then leaves them there. In the context of unipolar actuators (e.g. heating and cooling) it makes sense to combine two unipolar actuators into one bipolar actuator using a split-range function block.

2.2.2.1 Hard- and Soft Constraints

MV limitations are 'hard constraints' that always have to be accepted by the controller. On the other hand, CV constraints (control zones) are 'soft constraints': violations of such constraints are regarded as control deviations and avoided as much as possible. However, there can actually be a temporary violation of a CV constraint, similar to an overshoot with respect to an exact setpoint.

In multivariable controllers, it is advisable to make use of the fact that from the perspective of the application, only some of the controlled variables need to move to a specified setpoint exactly while others only need to remain within a defined range. A typical example would be

quality characteristics for which a tolerance band is specified. In principle, the effect of the control zones of an MPC is the same as the effect of a dead band in a PID controller but extends over the entire future prediction horizon. In other words, if, for example, the predicted controlled variable CV1 in the entire prediction horizon is within the band $SP1 \pm SP1DeadBand$, the controller sees no reason whatsoever to change any manipulated variable. While a dead band in a PID controller tends to put stability of the control loop at risk, CV zones in individual control channels of an MPC generally relieve the multivariable controller overall. Using CV zones, the action of a soft override control can be achieved. If one CV must be limited only in one direction, e.g. prevented from violating an upper limit, the exact setpoint is not relevant. Setpoint and zone width are then specified such that the lower limit is never reached during operation.

2.3 Configuration of APC-Functions

After selection of an appropriate control algorithm and design of the control system structure, the next step is the configuration, i.e. the parameterization and commissioning of the control function. For PID controllers and MPC functions there are dedicated software tools like e.g. PID-Tuner and MPC-Configurator.

The principal procedure however is the same for all controller types that rely on a model of process dynamics for controller design. Such a model must be identified from learning data because it is not usually known beforehand.

2.3.1 Process Excitation and Recording of Learning Data

In order to identify the process dynamics from learning data, the process must be stimulated to move i.e. actively excited via the MVs. If at least a stable and not too oscillatory (although sub-optimal) controller already exists, the excitation can be achieved by setpoint steps in automatic mode; otherwise MV moves in manual mode are necessary.

It is important to perform the experiment at exactly the same operating point and under exactly the same conditions that are designated for operation of the controller in order to really observe the process behaviour relevant for control. Before starting the experiment, a steady state of the process is required, because transients that have not yet faded away and have been caused by phenomena outside the learning data will spoil the estimation results.

During the recording of learning data, significant disturbance events must be avoided such as load changes; grade changes of raw materials; setpoint steps of neighbouring control loops; maintenance activities in the plant; significant modifications in upstream plant sections or in the mains power or steam supply, etc.

There are different possibilities for the choice of the excitation signal. For PID tuning a single step response is normally sufficient. For the identification of MIMO processes, all MVs must be excited, ideally one after the other. Signals symmetrical to the operating point are preferred, i.e. small steps upwards and downwards from the operating point. The amplitude of the excitation must be carefully specified and discussed with facility and plant operators:

- The amplitude should be large enough to make sure that the process response is clearly visible relative to measurement noise (signal-to-noise ratio).
- It must not be too large to avoid process nonlinearities having a strong impact.
- It should be not bigger than necessary to avoid distraction of running production.
- In the MIMO case, the process should be excited uniformly with respect to all CV channels, i.e. MVs with weak impact must be excited with bigger amplitudes.

Note: the routine inspections related to controller commissioning (cf. section 2.3.4) have to be performed before recording of learning data in the context of computer aided control system design.

2.3.2 Modelling

The identification of the dynamic process model from learning data is performed in most of the respective software tools automatically without prompting the user for dedicated specifications of a model structure. Simple functions for data-pre-processing are sometimes offered e.g. selection of a relevant time slice from a longer archive data set, or low-pass filtering for reduction of measurement noise.

Verification of the model is generally very important, i.e. comparison of a simulation of the identified model to real measured data, in order to check if the model response sufficiently fits the response of the real process. Ideally, different excitation signals are used for verification and learning data. Moreover, it is recommended to check the plausibility of the model at a descriptive level, e.g. using model parameters or model step responses: are gains and time constants in

the order of magnitude expected from physical conceivabilities or other a priori knowledge?

2.3.3 Controller Tuning

Similar to model identification, controller design is performed automatically by the related software tools. The specifications for controller design naturally differ for different controller types.

2.3.3.1 PID-Tuner

In PID-Tuner, the user can specify the controller structure: P-, PI- or PID-controller. PI control is applied in most cases. P controllers are suitable especially for integrating processes like e.g. level control. The differential action of a PID controller allows faster control response and better compensation of disturbances if stronger movements of the actuators are accepted (wear, energy consumption).

PID controllers principally allow modifying the proposed parameters manually (fine-tuning) and many tuning tools allow study of the response of the closed control loop in a simulation before new parameter sets are downloaded into the target system.

2.3.3.2 MPC-Configurator

The response of a predictive controller is mainly determined by the process model used inside the controller. Internal parameters like prediction horizon and control horizon can be specified automatically based on the process model.

The user only has to specify CV priorities and MV move penalties in the performance index as described in section 1.4.3. Manual tuning of other controller parameters is not possible for MPC, just the simulation of the closed control loop.

2.3.4 Commissioning

If the closed loop response has been already checked in simulations, the risks for controller commissioning are reduced. Before really closing the loop, you should generally check...

- if the measured CVs arrive correctly at the controller in the physical unit of the setpoint specification
- if the MVs have an impact on the process at all, i.e. if the CVs respond to small MV steps in manual mode
- if the specification of MV limits fits to the process actuator

- if the sign of the controller gain (of PID controller) fits to the sign of the process gain
- if additional calculations for pre- or post-processing of controller signals (e.g. unit transformations, measurement corrections, linearization functions according to section 2.2.1.2.1) are working properly.

Frequently (hopefully), these checks have been performed before recording learning data (c.f. section 2.3.1).

Typically, during commissioning the process is driven to the operating point in manual mode of the controller and at the operating point, a bumpless switchover from manual to automatic mode is performed. If the controller does not respond as expected, it is immediately switched back to manual mode. In very critical processes, MV limitations are limited to a very small zone around the current MV value before the controller is switched to automatic mode for the first time.

Only MPC allows running the controller 'passively' in automatic mode without connecting its MVs to the process. This way, the MV proposals of the MPC can be checked for plausibility and eventually typed in manually: 'advisory control', 'human in the loop'.

In contrast to that, a PID controller is not allowed to run in automatic mode without connection of its MV to the process because this would cause integrator windup.

If the control loop is running stably in automatic mode, the concrete requirements with respect to control performance are checked in detail. A first impression of control performance gain can be obtained by a small setpoint step. In the MIMO case too, setpoint steps are initially tested at single CVs, and the (undesired) 'crosstalk' to neighbouring control channels is observed as well. If possible, certain operating procedures or disturbance scenarios relevant for control operation are played through and tested e.g. load changes; grade changes of raw materials; limitations in heating or cooling system etc. Otherwise, the disturbance response can be tested by an artificial MV step. Most controller function blocks offer an input variable for offsets to the MV.

A control performance monitoring system according to section 1.2.1 can be initialized after successful controller commissioning.

2.4 The Most Important Rules at a Glance

- First check instrumentation and then tune controllers.
- For cascade structures, first tune the slave controller and then the master controller.
- First optimize the basic control loops and then design APC functions.
- If several MVs come into consideration, select the MV with the strongest impact (in the sense of gain) and the most direct impact (in the sense of small time lag).
- The general aim is to design the overall response of controlled plant and compensation blocks as linearly as possible.

2.5 Documentation, Training and Maintenance

It is good practice in the sense of benefit control to compare the performance of an APC solution to the performance of the automation system existing beforehand (conventional control or manual operation) and to document the difference.

In order to ensure the long term benefit of advanced control, documentation, training and maintenance play an important role. A functional documentation of the APC solution should allow usage and maintenance of the solution, even for people who have not participated in the design of the solution. Especially in the context of a first-time application of APC in a facility, confidence-building measures are very important to motivate plant operators, process and automation engineers and facility managers. Essentially, the attitude 'rather a bad solution than a solution that I don't understand' must be overcome. The functionality of most APC solutions can be described in an illustrative way like in chapter 1 of this document, and as can be seen from section 1.4.1, even for MPC, a basic understanding of the approach can be achieved without diving deeply into the mathematical theories. Formal and on-the-job training have to be considered separately. In spite of the required effort, it is recommended to offer different training for different target audiences with different focus and different coverage.

To this end, it is helpful to provide a simulation environment not only in the design and training phase of an APC project but also in the operating phase.

Process plants are subject to permanent modifications, like a living organism. Modifications result both from undesired aging processes like catalyser deactivation or heat exchanger fouling and from conscious measures of maintenance, modification or expansion of the plant in the operational phase. This implies that the static and dynamic behaviour of a process plant is subject to changes - slower or faster, smaller or bigger. You must be aware of the fact that the process models used for APC in the course of time will diverge more and more from reality, implying negative effects on control performance. Maintenance of an APC solution requires permanent observation and evaluation and in this context the tools for control performance monitoring described in section 1.2.1 are helpful. Suggested actions are scheduling of an appropriate date for re-identification of some or all process models; eventual re-configuration of the APC solution (include new MVs or CVs, or eliminate MVs or CVs that are no longer necessary or available); re-commissioning and last but not least, the initialization of follow-up projects.

3 Case Study Distillation Column

Distillation is one of the most important separation processes in the chemical-pharmaceutical industry. It is a thermal separation process to separate a mixture of several fluids dissolvable in each other, making use of the different relative evaporation and boiling points. Typical application areas of distillation are alcohols or crude oil. There are two main classes: (1.) batch distillation, and (2.) continuous distillation (e.g. rectification, extractive or reactive distillation.). In rectification (counter flow distillation), a mixture of several components is separated in at least two fluid streams. At the column head, the head product (low-boiling component) is extracted, and at the column bottom, the bottom product (high-boiling component).

Due to the strong thermodynamic interactions inside the distillation tower, conventional PID control technology can only control the product quality (concentration, or substituted by temperature) either at the head or at the bottom of the column. Therefore, up to now there are 5 different alternative structures for distillation column control via one single temperature [12].

Thanks to the routine application of a MIMO controller with two MVs and two CVs, now for the first time all columns that have been driven with one of the five conventional control structures up to now, can be equipped with the same

standard automation structure: [10.]. This standard structure comprises a complete quality control: control of head- and (!) bottom temperature via reflux and heating vapour flow. The relative importance of the CVs for an individual

application can be specified using the CV priorities in the performance index of the MPC.

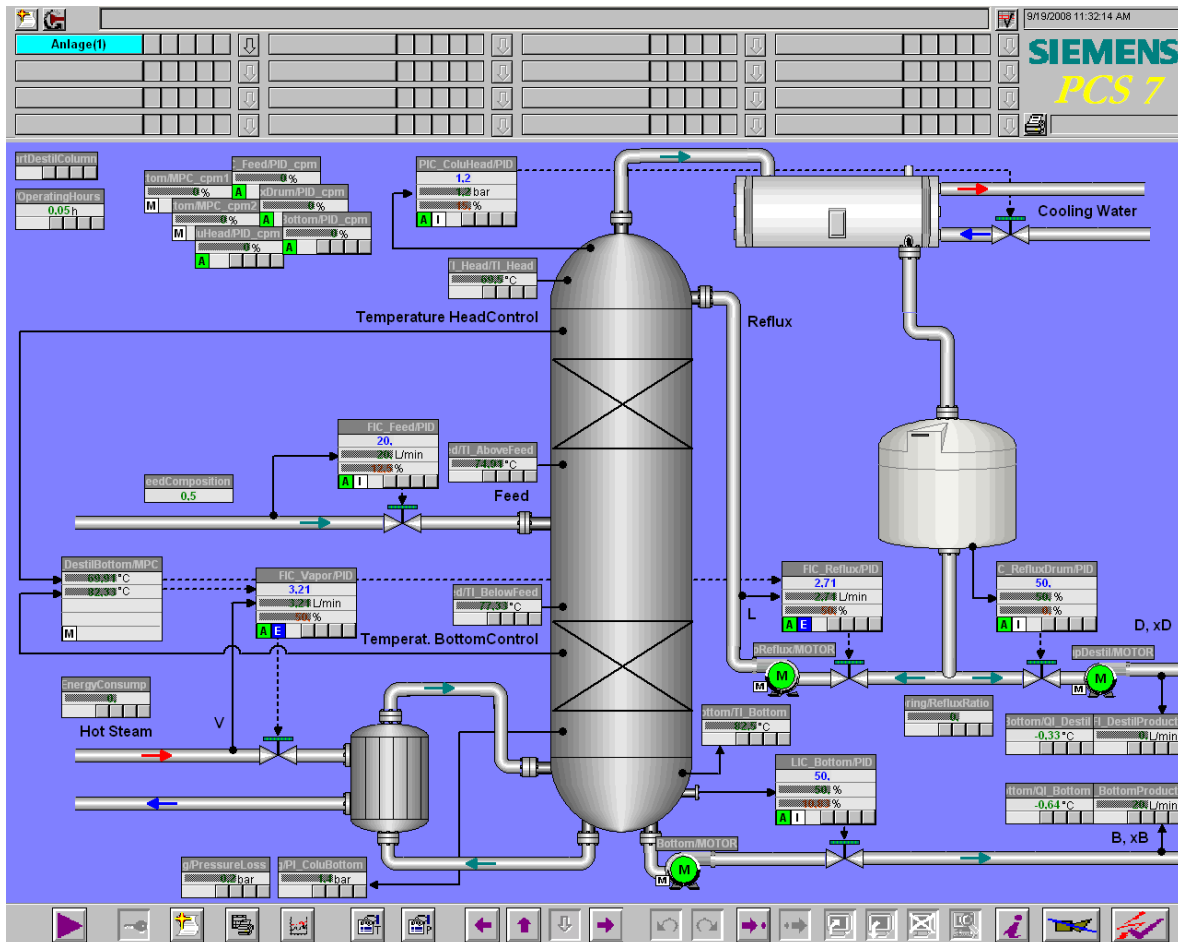

Figure 16: P&I diagram for a rectification column with quality control via MPC. (Source: OS picture of the PCS 7 solution template described in [10.] . The measured values are greyed, because here they are in status simulation.)

3.1 Template-based Implementation

The CFC template (process tag type) for the predictive controller is the starting point for the implementation of the multivariable controller. This signal flow chart is modified at the output side: the output variables of the predictive controller are not directly connected to the plant but are connected as external setpoints to the existing PID flow controllers for reflux and heating steam.

Because this is actually a cascade structure (with one MIMO master controller and two PID slave

controllers), the usual guidelines for the engineering of cascade control structures have to be considered as shown in the CFC template cascade control:

- The actuation range of the primary controller (in the respective MV channel) must match the setpoint range of the secondary controller to ensure proper operation of the anti-windup functions of the primary controller.
- If the secondary controller is not operated in cascade mode (automatic mode with external setpoint) but in any other mode (for example manual or automatic mode with local setpoint) and therefore does not respond to

commands of the primary controller, the corresponding channel of the primary controller must be put into tracking mode. The manipulated value of the primary controller tracks the process value (or setpoint) of the corresponding secondary controller to allow a bumpless return to cascade mode. The difference between tracking the setpoint and tracking the process value becomes apparent when the secondary controller is put into manual mode. If the process value is tracked, the response is similar to the 'Track setpoint to process value in manual mode' of a simple controller.

- Commissioning of cascade control structures is performed from inner loop to outer loop, i.e. first all slave controllers are optimized with the PID tuner and afterwards the master controller is tuned by the MPC configurator.

Due to the nonlinear thermodynamic effects in the distillation column, quality control with a linear MPC is only feasible in a limited range around a defined operating point. Therefore it is important to do experiments for recording learning data at this operating point and to restrict the MV range of the MPC for automatic mode to the validity range of this linear model. The MV limits for manual mode however should span the whole SP range of the slave controllers in order to allow start up and shutdown of the process in manual mode of quality control.

When using the standard CFC templates of the PCS7 APC library, control performance monitoring according to section 1.2.1 for all PID loops and the MPC is automatically included in the project.

3.2 Economic Benefit

What is the economic benefit of the APC solution 'quality control by MPC' in the context of distillation columns?

- Now for the first time it is possible to specify the quality of head and bottom product individually and control it in closed loop. The variance of the quality parameter, which was not controlled at all before, can be dramatically reduced; the variance of the quality parameter, which was PID controlled before, can still be significantly reduced. Overall process control is more even and smooth with product quality more exactly adjustable. Smaller variances of product quality typically allow for savings in downstream processing units, e.g. reduced consumption of additives.
- Automatic quality control needs less operator attention, i.e. number of manual inter-

ventions and operator workload are reduced accordingly.

- Feed flow as the main measurable disturbance variable is used to improve prediction accuracy, in order to compensate for feed flow fluctuations in a predictive way by adjusting reflux and heating steam without tolerating significant product quality deviations from setpoint. Control performance in this respect can be improved significantly compared to conventional PID control.
- The main economic benefit however can be achieved according to Figure 15 by a dedicated move of the quality control setpoints. The constraints for allowed head and bottom temperatures result from specifications of product quality, considering actual variances of controlled variables. For optimal operation of the column with minimal energy consumption (i.e. steam consumption), the head temperature setpoint is selected as high as possible and the bottom setpoint as low as possible, i.e. the temperature span inside the column is minimized. In other words, do not produce the best quality achievable, but exactly this acceptable quality that can be produced with minimal costs. In other plant constellations there can be other optimization targets. For example, maximize throughput by increasing feed flow step by step under quality control until heating steam flow is settling close to the upper limit.



Figure 17: Distillation columns

The overall benefit of an APC solution for a distillation column (like that described e.g. in [13.]) typically adds up to more than €100,000 per year.

Typical empirical values for the benefit of APC solutions are:

- Throughput increased by 1...5%
- Yield increased by 2..10%
- Energy consumption reduced by 3...10%
- Standard deviation of process variables reduced to 25...50% of the value before.

3.3 Summary

APC methods are a tool of vital importance to improve plant performance with respect to productivity and economics, product quality, operability and availability, agility, safety and environmental issues.

APC solutions can be realized much more cost effectively due to a DCS embedded implementation with standard function blocks and pre-defined CFC templates as offered by Siemens in the APC library.

4 Literature

- [1.] Siemens AG, Automation and Drives: Online-Hilfe zur PCS7 APC-Library V7.0 SP 1, Nov. 2007.
- [2.] Siemens AG, Sektor Industry: Online-Hilfe zur PCS7 Advanced Process Library V7.1, Nov. 2008.
- [3.] Siemens AG, Sektor Industry: PCS7 AddOn-Katalog. (available at www.automation.siemens.com)
- [4.] Dittmar, R., Pfeiffer, B-M.: *Modellbasierte prädiktive Regelung - Eine Einführung für Ingenieure*. Oldenbourg Verlag, München, 2004.
- [5.] Dittmar, R., Pfeiffer, B-M.: *Modellbasierte prädiktive Regelung in der industriellen Praxis*. at 12/2006, S. 590-601.
- [6.] Pfeiffer, B-M.: *Control Performance Monitoring mit einer Kombination aus stochastischen und deterministischen Merkmalen*. GMA-Kongress 2005, Baden-Baden. VDI-Berichte 1883, VDI-Verlag, Düsseldorf, S. 411-420.
- [7.] Föllinger, O.: *Regelungstechnik*. 6. Auflage, Hüthig-Verlag, Heidelberg 1990.
- [8.] Preuß, H.-P., Linzenkirchner, E., Kirchberg, K.-H.: *SIEPID – ein Inbetriebsetzungsgerät zur automatischen Regleroptimierung*. Automatisierungstechnische Praxis atp 29(1987), Heft 9, S. 427-436.
- [9.] Pfeiffer, B-M.: *Standardisierung gehobener Regelungsfunktionen als Messstellen-Typen*. GMA-Kongress 2007, Baden-Baden. VDI-Berichte 1980, VDI-Verlag, Düsseldorf, S. 83-94.
- [10.] Pfeiffer, B-M., Lorenz, O.: *Unit-orientierte Musterlösungen für Advanced Control (Unit-oriented solution templates for advanced control) - Beispiel Destillationskolonne (Example distillation column)*. Automation 2008, Baden-Baden. VDI-Berichte 2032, S. 11-14, VDI-Verlag, Düsseldorf.
- [11.] Pfeiffer, B-M.: *PID-Regelung von Batch-Prozessen entlang vorab optimierter Trajektorien – Studien am Chylla-Haase Reaktor-Benchmark*. atp 4/2003, S. 76-86.
- [12.] Kister, H.Z.: *Distillation Operation*. Mcgraw-Hill Professional, 2007.
- [13.] Schüler, M.: *Implementing MPC at Ineos Phenol's Gladbeck site*. Hydrocarbon Engineering, Vol. 11, No. 10, Oct. 2006.
- [14.] VanDoren, V.: *Advances in control loop optimization. Software takes users from simple tuning to plant-wide optimization*. Control Engineering May 2008.

www.siemens.com

All rights reserved. All trademarks used
are owned by Siemens or their respective owners.

© Siemens AG 2008

Siemens AG

Sektor Industry, IA AS SM MP7
Östliche Rheinbrückenstr. 50
D-76181 Karlsruhe