

# Analytical Simplicity

## Exchangeable Column Modules for MAXUM with Modular Oven

[usa.siemens.com/processanalytics](http://usa.siemens.com/processanalytics)

No matter how many online process gas chromatographs (GCs) you use, you want long-term, stable performance and simple, fast analytical maintainability. By utilizing Siemens MAXUM with modular ovens with proven exchangeable column trains and applet modules, we make maintenance and repair as simple as installing an identical applet module.

The simple design of standardized applets and the possibility of quick exchange reduce analyzer downtime and improve maintenance and probability of successful repair the first time, even by a non GC expert.

From our U.S. factory, we offer exchangeable applet modules as default analytical configuration where possible. In addition to maintaining and repairing the analytics as before, this option allows you to maintain and repair simply by exchanging applet modules.

### Designs based on decades of experience

Siemens exchangeable applet column modules are the product of 50 years of design and maintenance experience with analytical devices. A history of innovation and reliability is why so many operators depend on the Siemens analytical measurement system for generating critical process data.

### Parallel chromatography

The MAXUM Process Gas Chromatograph introduced parallel chromatography, a major advance that greatly simplifies the chromatographic separation. Parallel chromatography relies on one or more simple and standard applet separation system. Applets eliminate the need for customized configurations based on complex arrangements of multiple valves and columns. Simplifying the segmentation of complex or multivalve separation systems into smaller, simpler portions eliminates the need for tedious valve switching and peak gating adjustments.

Parallel chromatography is the standard separation solution for MAXUM, except when the measurement task prohibits this approach. Each applet consists of a single multiport diaphragm valve, two separation columns in a backflush configuration, and a four-channel thermal conductivity detector (TCD) with inter-column (ITC) measurement capabilities.

Multiple applets operate simultaneously in parallel. Such simplified chromatographic separation typically provides a shorter cycle time, easier data interpretation, simpler troubleshooting, and faster repair and maintenance. The individual hardware of an applet, such as valve, columns and detectors are installed individually inside the analyzer oven. Consequently, the analytical maintenance of each item is performed in the analyzer.

Designing standardized applets as a module, with defined gas and electrical connectivity means you can maintain modules using existing practices or simply exchange them for an identical spare. Each module consists of a single or dual applet, each with a dedicated Model 50 valve for injection and backflush and a four channel TCD for detection and inter column monitoring.



Single Train Column Module

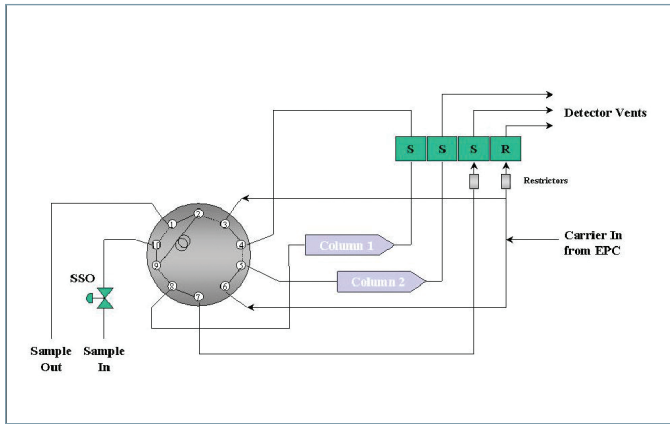

Applet, a simple standardized column train

The base plate combines the Model 50 valve, the TCD, the separation columns with the mounting panel for carrier and sample gas, the vent lines and the electrical connections to the TCD. The MAXUM with modular oven can be equipped with two ovens in one analyzer. Each oven can accommodate a single or dual separation module. The entire applet module can be exchanged in minutes. The design, functionality and the simple and quick exchangeability has been proven over the years.

### How does the MAXUM design benefit you?

#### Maintenance and Repair Inside the Analyzer

You can maintain the column trains using existing practices. The intuitive design permits you to easily replace individual parts and to adjust pressure, valve, and peak gates.

#### Maintenance and Repair by Exchange

With the standardized design, you can exchange a module for an on-site spare in minutes. Each factory tested module is delivered with individual electronic pressure control settings for optimum component separation and repeatable valve and peak retention times. Thus, only fine tuning of backflush timing and peak gate setting may be necessary to get the analyzer back on-line quickly after calibrating.

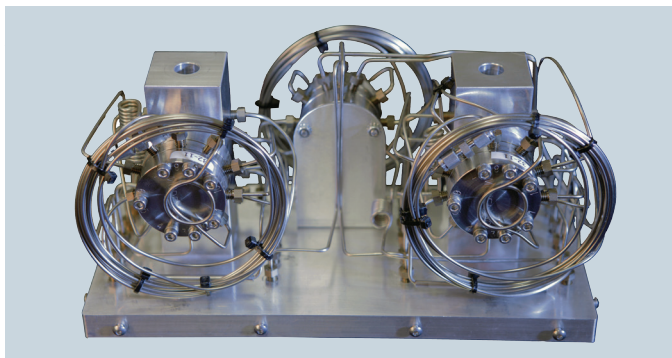

Dual Train Column Module

#### For more information please contact:

5980 West Sam Houston Parkway North  
Suite 500  
Houston, TX 77041  
713-939-7400  
ProcessAnalyticsSales.industry@siemens.com



Single and Dual Applet Modules in a single and dual Modular Oven

The applet module can be repaired at your shop with the simple replacement of valves, columns, or TCD thermistors. To be able to test the pressure integrity and the electrical TCD continuity of the module, indicating successful repair with high likelihood, a module test tool device is available. These tests are essential for confirming that the applet module has been repaired correctly, is functional, and is therefore ready for installation.



If onsite repair is not possible, you can send the module to the U.S. Siemens Process Analytics factory. We can provide replacement modules quickly that are conditioned and tested.

Combining the simplicity of MAXUM parallel chromatography with the simplicity of maintainability ensures ease of understanding, long term reproducible performance, simple repair and thus short off-line time.

**We are Siemens. We can do that.**

Published by  
**Siemens Industry, Inc.**  
Process Automation  
Process Industries and Drives  
100 Technology Drive,  
Alpharetta, GA 30005  
1-800-964-4114  
info.us@siemens.com

Subject to change without prior notice  
Order No.: PIAFL-00037-0318  
Printed in USA  
All rights reserved  
© 2018 Siemens Industry, Inc.

The technical data presented in this document is based on an actual case or on as-designed parameters, and therefore should not be relied upon for any specific application and does not constitute a performance guarantee for any projects. Actual results are dependent on variable conditions. Accordingly, Siemens does not make representations, warranties, or assurances as to the accuracy, currency or completeness of the content contained herein. If requested, we will provide specific technical data or specifications with respect to any customer's particular applications. Our company is constantly involved in engineering and development. For that reason, we reserve the right to modify, at any time, the technology and product specifications contained herein.