

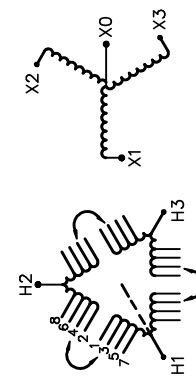

REVISION	DATE	BY	DATE	BY
			16/10/06	PP
			CHEK'D	
1 ADDED ENCL BOTTOM DRAWING	17/04/03	JW	VERIF'D	

Siemens Industry, Inc.		
CUSTOMER		
ORDER NO.	DWG. NO.	1
	3F3Y500BLN3D16	SH 1 OF 3

# SIEMENS

<p>CATALOG NO. 3F3Y500BLN3D16</p> <p>SERIAL NO. SERIES H</p> <p>500 kVA 60 Hz 3 PHASE</p> <p>5.4 % IMP AT 100 °C</p> <p>80 °C RISE 30 °C AVG. AMBIENT</p> <p>220 °C TEMP CLASS 40 °C MAX. AMBIENT</p> <p>PRIMARY ( H1 H2 H3 ) 480V V 10 kV BIL</p> <p>SECONDARY( X0 X1 X2 X3 ) 208Y/120V V 10 kV BIL</p> <p>WINDING MATERIAL AL</p> <p>ENCLOSURE TYPE 3R WEIGHT 3350LBS</p> <p>ENERGY EFFICIENCY EXCEEDS CSA C802.2-2012 DOE 10 CFR PART 431:2016</p> <p>SPACINGS BETWEEN ANY VENTILATED ENCLOSURE PANEL AND ANY ADJACENT WALL SHALL BE A MINIMUM OF 12 INCHES</p> <p>SOUND LEVEL 3dB BELOW NEMA ST20 REQUIREMENTS</p>	 <p style="text-align: center;">VOLTS</p> <p>504 492 480 468 456 444 432</p> <p style="text-align: center;">CONNECT</p> <p>1-2 2-3 3-4 4-5 5-6 6-7 7-8</p>	<p style="text-align: center;">TYPE K</p> <div style="display: flex; justify-content: space-around;">   </div> <p style="text-align: center;">LISTED</p> <p>SEISMIC QUALIFICATIONS, FLOOR MOUNT ONLY OSP-0136-10 IBC 2012/ASCE 7-10 SDS&lt;=2.0g Z/h=1 Ip=1.5</p> <p style="text-align: right;">Siemens Industry, Inc. Norcross, GA <small>dsu0086e</small></p>
--	---	---



FRONT VIEW

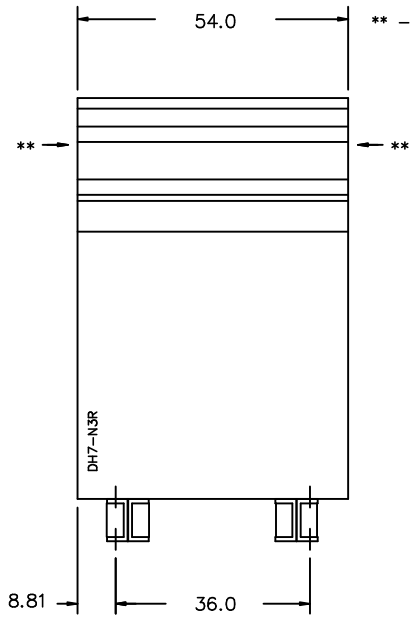

\*\* - Recommended cable entry locations only  
cutouts & gland plates not provided.

SIDE VIEW

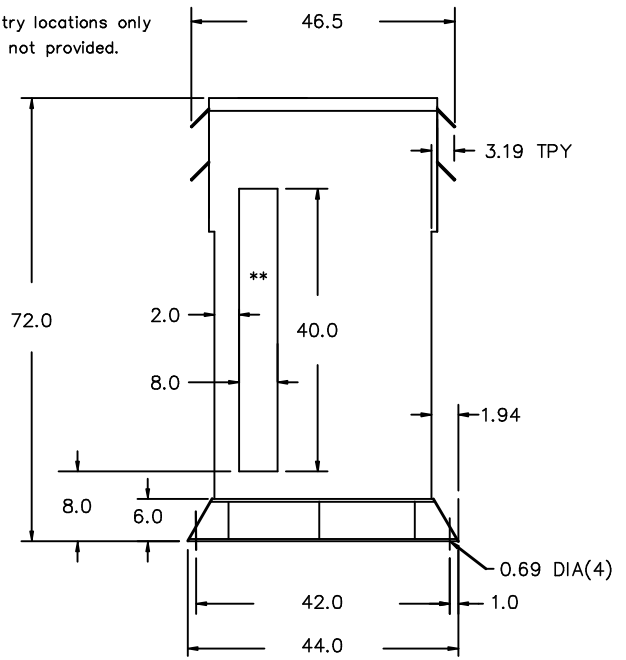

All Dimensions in inches

ENCLOSURE COLOR : ANSI 61 GREY - OUTDOOR

H.V.1. TERMINAL DETAIL

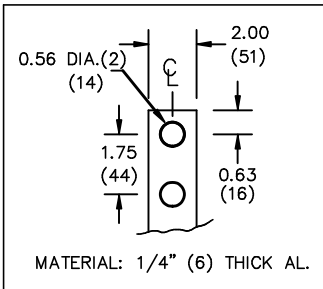

L.V.1. TERMINAL DETAIL

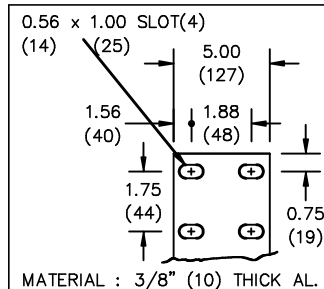

CUSTOMER NOTES:

- HV1 TERMINATED AT TOP FRONT
- LV1 TERMINATED AT BOTTOM FRONT

Siemens Industry, Inc.

REVISION	DATE	BY	DATE	BY	CUSTOMER		
			16/10/06	PP			
			CHEK'D				
1	ADDED ENCL BOTTOM DRAWING	17/04/03	JW	VERIF'D			
					ORDER NO.	DWG. NO.	1
					3F3Y500BLN3D16		SH 2 OF 3

ENCLOSURE BOTTOM VIEW

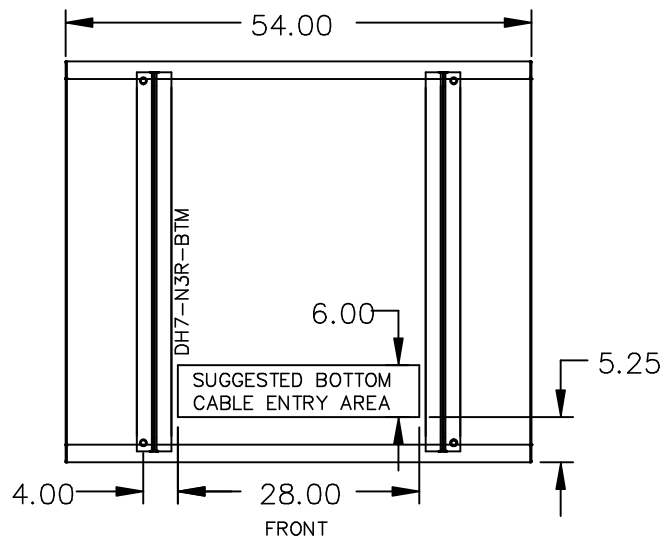

NOTE:  
 WHEN BOTTOM CABLE ENTRY IS OPTED, THE SPACE USED FOR CONDUITS IN THE FRONT OF THE TRANSFORMER SHOULD NOT OBSTRUCT MORE THAN 50% OF THE FRONT AIR INTAKE AREA DEFINED BETWEEN THE BOTTOM PLATE AND THE SUPPORTING LEGS.  
 SEE MANUAL FOR ADDITIONAL INFORMATION

Siemens Industry, Inc.

REVISION	DATE	BY	DATE	BY	CUSTOMER		
			16/10/06	PP			
			CHEK'D				
1	ADDED ENCL BOTTOM DRAWING	17/04/03	JW	VERIF'D			
					ORDER NO.	DWG. NO.	1
					3F3Y500BLN3D16		SH 3 OF 3