

GEMCMS

COLLISION MONITORING AND MACHINE PROTECTION MODULE

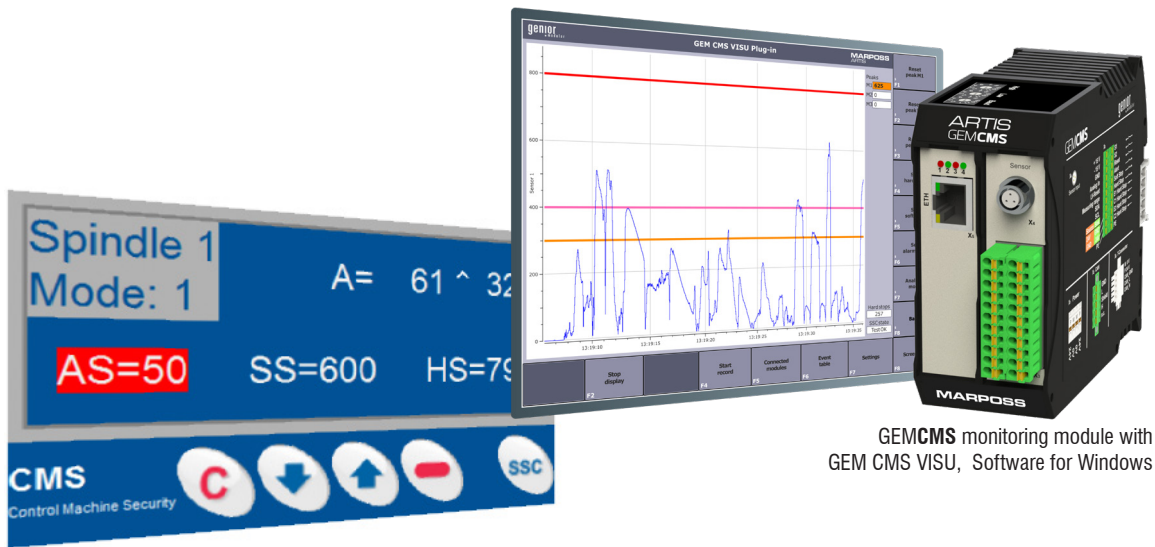

GEM CMS-L VISU, Software for IPC4 (LINUX)

GEMCMS monitoring module with GEM CMS VISU, Software for Windows

Application example

Stand-alone operation:

GEMCMS is the ideal solution for detecting dynamic and quasi-static collisions. The following application example shows a GEMCMS module with GEM CMS VISU software (here via IPC10) and a strain sensor DA (order separately).

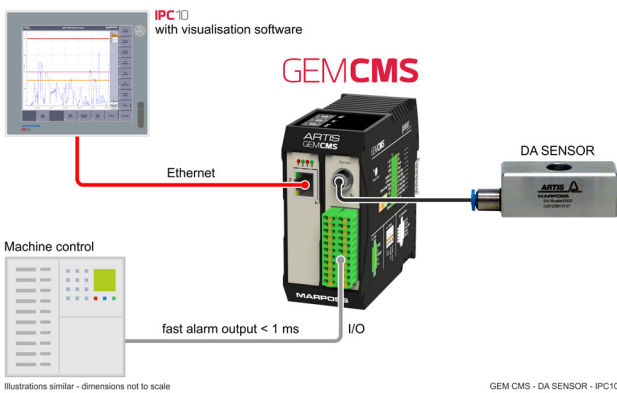

Illustrations similar - dimensions not to scale

GEM CMS - DA SENSOR - IPC10

For all technical details, please refer to individual sensor data sheets.

Properties

- Collision detection at fast and low feed rate
- Compact control cabinet module with integrated load amplifier
- 25 kHz sampling rate, 16 bit resolution
- Physical I/O-interface (3 inputs – 4 outputs)
- 3 different operation modes with 3 different static limits each
- Fast alarm outputs (< 1 ms)
- Stop event data recording (black box)
- Signal values log file
- Optional: ToolPlus – tool-related limits via Profibus or Profinet

GEMCMS can be used as GENIOR MODULAR component via the CAN bus connection:

- Plug-in integrated in MultiView
- Stand-alone functions remain active

Article number

- GEMCMS Monitoring module 0830B230004

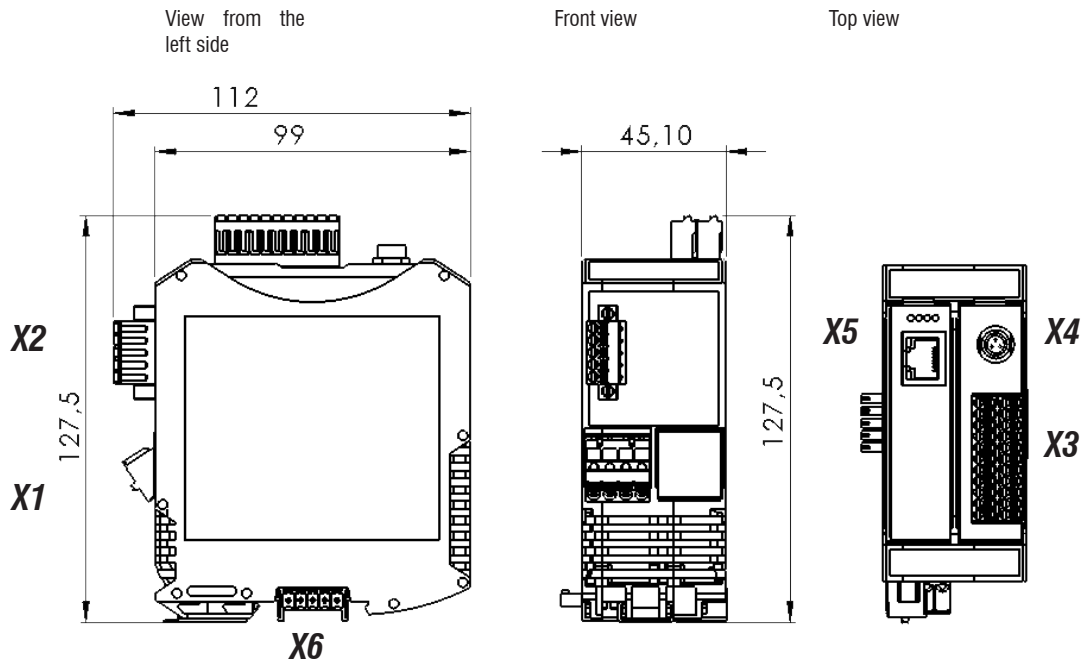

GENERAL DATA	
DIMENSIONS	see drawing
STANDARD IP-ADDRESS	192.168.214.84
WEIGHT	0.236 kg
MATERIAL	Polyamide PA 6.6
STORAGE TEMPERATURE	-20 °C ... +60 °C
OPERATING TEMPERATURE	0 °C ... +50 °C
UL-CLASSIFICATION	VO (UL94)
DEGREE OF PROTECTION	IP30
REL. HUMIDITY	5 % ... 85 %, no condensation
INSTALLATION	DIN EN 60715 standard mounting rail
CONTACTING	Spring terminals, in-rail bus connector

MEASUREMENT	
MEASURING INPUTS	1 x piezoelectric sensor, pls. order separately
ACCURACY	< 0.5 %
FREQUENCY RANGE	0.4 Hz ... 2 kHz
SAMPLING RATE	25 kHz
RESOLUTION	16 bit

VISUALIZATION	
FOR WINDOWS	GEM CMS VISU Software
FOR IPC4 (LINUX)	GEM CMS-L VISU Software
CONFORMITY	CE, UKCA

CONNECTIONS	
CONNECTION X1	24 V DC \pm 20 %, max. 5 % ripple (via in-rail bus connector)
CABLE CROSS SECTION	0.2 ... 2.5 mm ²
NOM. CURRENT CONSUMPTION	max. 200 mA
CONNECTION X2	CAN bus
CABLE CROSS SECTION	0.2 ... 1.5 mm ²
CONNECTION X3	Machine and load amplifier interface
CABLE CROSS SECTION	0.2 ... 1.5 mm ²
IN-/OUTPUT SIGNALS	3 input signals, 5 output signals
INPUTS	
1-SIGNAL SOURCE	8 V ... 36 V / 5 mA
0-SIGNAL SOURCE	0 V ... 7 V / 5 mA
1-SIGNAL SINK	0 V ... 19 V / 5 mA
0-SIGNAL SINK	20 V ... 36 V / 5 mA
OUTPUTS	
1-SIGNAL SOURCE	24 V typical, max. 100 mA
0-SIGNAL SOURCE	open
1-SIGNAL SINK	0 V ... 1 V
0-SIGNAL SINK	open
CONNECTION X4	Sensor connection
CONNECTION X5	10/100 base T Ethernet
CONNECTION X6	CAN bus / 24 VDC

OPERATION WITH GENIOR MODULAR	
Interface	CAN bus



www.marposs.com

For a full list of address locations, please consult the Marposs official website

ODN6422EN17 - Edition 01/2025 - Specifications are subject to modifications
© Copyright 2010-2025 MARPOSS S.p.A. (Italy) - All rights reserved.

MARPOSS,  and Marposs product names/signs mentioned or shown herein are registered trademarks or trademarks of Marposs in the United States and other countries. The rights, if any, of third parties on trademarks or registered trademarks mentioned in this publication are acknowledged to the respective owners.

Marposs has an integrated system for Company quality, environmental and safety management, with ISO 9001, ISO 14001 and OHSAS 18001 certification.



Download the latest version of this document

