

P2 & P3 Panelboard Kit BBKNB32 for Branch Mounting Type GB Breakers

Installation
Instructions

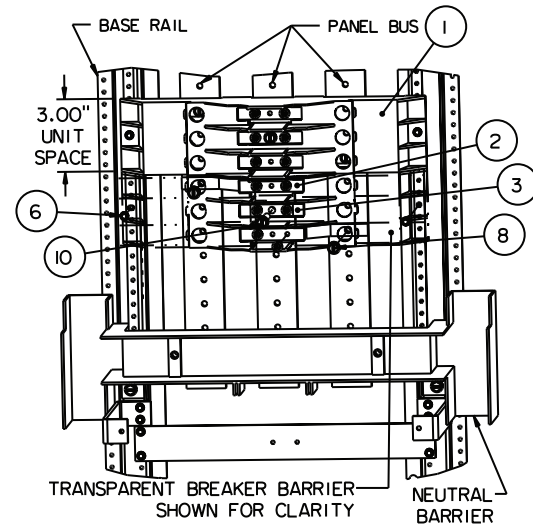

Figure 5

BRANCH BREAKER INSTALLATION (ALL PANELS)

8. Refer to Figure 6
Position each branch breaker so that the mounting notch on the load side of its case engages a mounting tab on the breaker mounting barrier (item 1). Bring each breaker line stab into contact with its connector bus and align all breaker stab holes with the corresponding connector bus holes. Ensure that each breaker maintains engagement with the mounting barrier.
9. Fasten each breaker line stab to its connector using a #10-24 x 5/8" screw (item 9) and tighten to the torque value specified on the back of the deadfront.

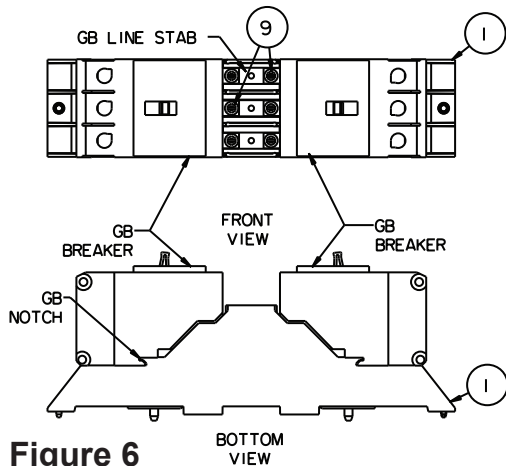

Figure 6

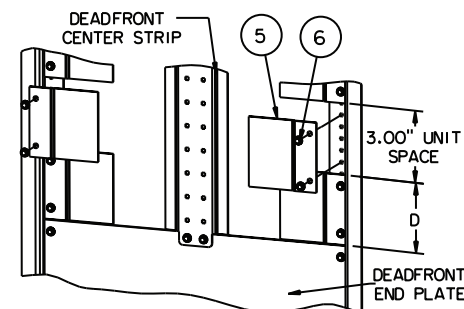

Figure 7

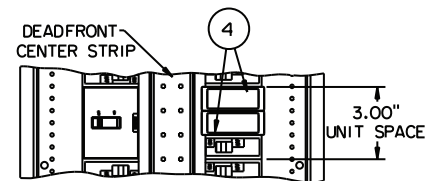

Figure 8

DEADFRONT MODIFICATIONS AND PANEL RE-ASSEMBLY

10. Remove any full width plate covering the deadfront area for the installed kit. On P2 deadfronts only, remove any center strips attached to the removed plate.
11. If the installed kit does not completely fill the unit space of a removed module, a deadfront filler plate kit is required. Use DFFP3 for 3" gaps and DFFP6 for 6" gaps.
12. For P2 deadfronts only, use kit DFK1 to install the appropriate length center strip to span any open deadfront area.
13. Refer to Figure 7
On P3 deadfronts only, install two deadfront adaptor plates (item 5) on the outside edges of the kit deadfront area at the kit unit space locating dimension D. Fasten the plates to the deadfront with four #8-32 screws (item 6).
14. Replace the deadfront using the hardware removed during disassembly.
15. Refer to Figure 8
Insert 1" deadfront fillers (item 4) into all P2 and P3 deadfront branch spaces not filled with breakers.
16. Tighten all hardware to the specified torque values on the back of the deadfront.
17. Replace the panelboard front cover using the hardware removed during disassembly.

These instructions do not purport to cover all details or variations in equipment, or to provide for every possible contingency to be met in connection with installation, operation or maintenance. Should further information be desired or should particular problems arise, which are not covered sufficiently for the purchaser's purposes, the matter should be referred to the local Siemens sales office. The contents of this Instruction manual shall not become part of or modify any prior or existing agreement, commitment or relationship. The sales contract contains the entire obligation of Siemens. The warranty contained in the contract between the parties is the sole warranty of Siemens. Any statements contained herein do not create new warranties or modify the existing warranty.

Trademarks - Unless otherwise noted, all names identified by ® are registered trademarks of Siemens AG or Siemens Industry, Inc. The remaining trademarks in this publication may be trademarks whose use by third parties for their own purposes could violate the rights of the owner.

Installation Instructions

The following instructions are for the installation of Siemens Type GB breakers (NGB, HGB or LGB) as branch devices in a Type P2 or Type P3 panelboard. The part provided in this kit connect Type GB breakers to 1-phase or 3-phase systems. The breakers are not included in this kit and must be purchased separately. This kit requires 3" of branch unit space. If the unit space location for the kit is presently covered on the deadfront by a single, full width plate, a P2 deadfront will require modifications using kit DFKI. Both P2 and P3 deadfronts will need a blank filler plate if this kit incompletely fills the interior unit space of any removed branch module(s). These deadfront filler kits are DFFP3 for a 3" gap and DFFP6 for a 6" gap. In P2 panelboards, use kit BKN2 if the branch neutral lugs do not have enough available sites for the breakers installed with this kit.



1. Lock off power supplying this equipment before working on it.
2. Remove the panelboard front cover and deadfront.
3. Refer to Figure 1
For taking unit space measurements in P2 panels, use the bus support located farthest from the main lug or device end of the panel. For P3 panels, use the neutral barriers if present, or the bus supports in panels without neutrals. Note that unit space starts at the inner surface of a P3 neutral barrier and 0.25" from the inner surface of a P2 or P3 bus support.

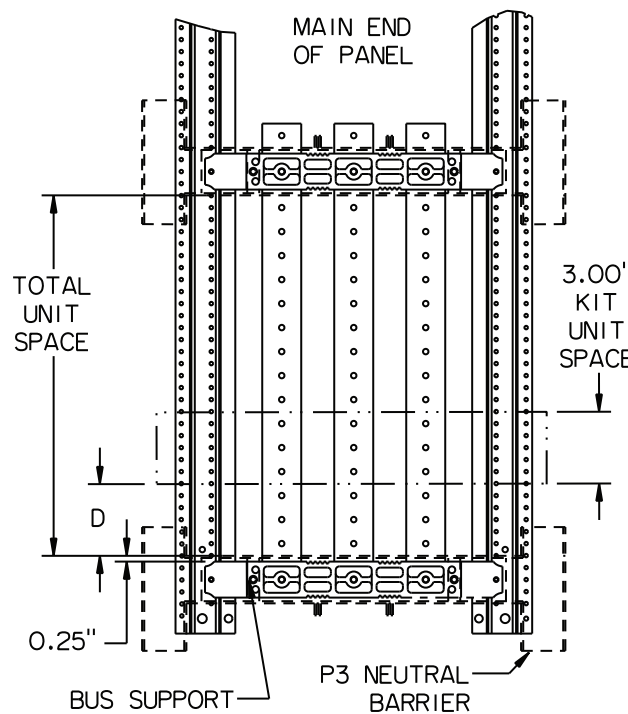

Figure 1

4. This kit requires 3" of unit space. Determine the location where the kit is to be installed. The kit positioning dimension D in Fig. 1 must be a multiple of 3" (e.g.: 0", 3", 6", 9", etc.). These measurements can be taken directly from a P3 neutral barrier. For measurements taken from a P2 or P3 bus support, add 0.25" to D (e.g.: 0.25", 3.25", 6.25", 9.25", etc.).
5. If an existing branch module occupies the location chosen for this kit, remove all of its devices, components and parts. If it is a 6" module, the entire 6" of unit space must be cleared.

THIS KIT CONTAINS THE FOLLOWING ITEMS:

ITEM	DESCRIPTION	QTY.
1	GB Breaker Mounting Barrier	1
2	Outer Connector Bus	3
3	Center Connector Bus	1
4	1" Unit Space Dead Front Filler	6
5	P3 Panel Dead Front Adaptor Plate	2
6	#8-32 Self-threading Screw	6
7	1/4"-20 X 5/8" Self-threading Screw	3
8	1/4"-20 X 1" Self-threading Screw	3
9	#10-24 X 5/8" Self-threading Screw	6
10	1/4"-20 X 2 1/4" Self-threading Screw	1
11	1/4"-20 X 1 7/8" Self-threading Screw	1

NOTE: Separate instructions are provided for kit installation for each system and panel type. Each application uses some, but not all of the above listed parts. Instructions for breaker installation and panel re-assembly are located on page 4.

INSTALLATION IN P2 1-PHASE PANELS

6. Refer to Figure 2
Position the breaker mounting barrier (item 1) so that it fills the 3" unit space for the kit and fasten it to the base rails using two #8-32 screws (item 6). Install the three outer connectors (item 2) within the mounting barrier, alternating between the left and right panel bus. The left-right-left connector pattern shown in Fig. 2 may be reversed if necessary to continue a connector pattern already in place in the panel. Fasten the connectors to the panel bus with three 1/4"-20 x 5/8" screws (item 7).
7. Tighten all screws to the torque values specified on the back of the deadfront.

CAUTION
Arcing Hazard.
May cause injury or property damage.
Use 5/8" long screws (item 7) in Type P2 5-3/4" deep panelboards to fasten the connectors.

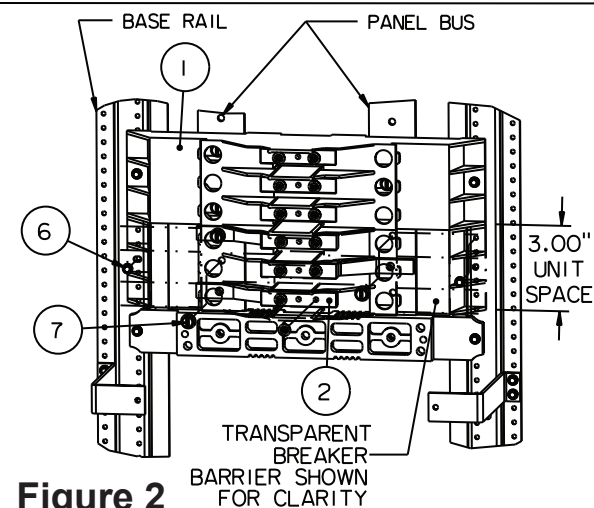

Figure 2

INSTALLATION IN P2 3-PHASE PANELS

6. Reference Figure 3:
Position the breaker mounting barrier (item 1) so that it fills the 3" unit space for the kit and fasten it to the base rails using two #8-32 screws (item 6). Install the two outer connectors (item 2) and the center connector (item 3) within the mounting barrier, as shown. Fasten the outer connectors to the panel bus with two 1/4"-20 x 5/8" screws (item 7) and center connector with one 1/4"-20 x 1-7/8" screw (item 11).

CAUTION
Arcing Hazard.
May cause injury or property damage.
Use 5/8" long screws (item 7) for outer connectors and a 1-7/8" long screw (item 11) for center connectors in Type P2, 5-3/4" deep panelboards to fasten the connector bus.

7. Tighten all screws to the torque values specified on the back of the deadfront.

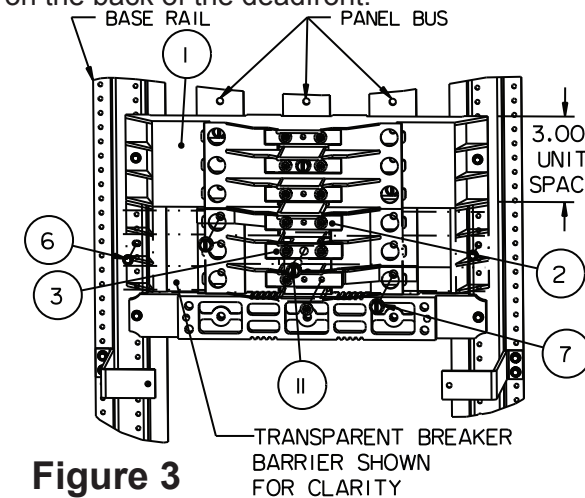

Figure 3

INSTALLATION IN P3 1-PHASE PANELS

6. Reference Figure 4:
Position the breaker mounting barrier (item 1) so that it fills the 3" unit space for the kit and fasten it to the base rails using two #8-32 screws (item 6). Install the phase connectors (item 2) within the mounting barrier, alternating between the left and right panel bus. The left-right-left connector pattern shown in Fig. 4 may be reversed if necessary to continue a connector pattern already in place in the panel. Fasten the connectors to panel bus with three 1/4"-20 x 1" screws (item 8).

CAUTION
Arcing Hazard.
May cause injury or property damage.
Use 1" long screws (item 8) in Type P3 7-3/4" deep panelboards to fasten the connectors.

7. Tighten all screws to the torque values specified on the back of the deadfront.

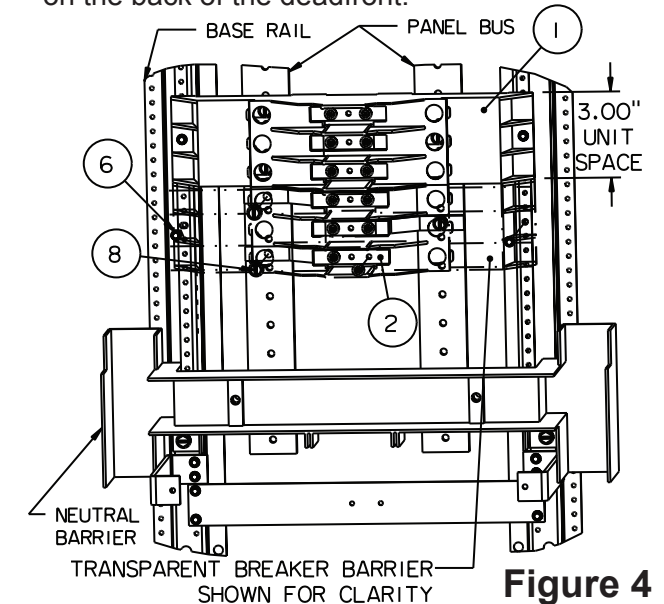

Figure 4

INSTALLATION IN P3 3-PHASE PANELS

6. Reference Figure 5 (on next page):
Position the breaker mounting barrier (item 1) so that it fills the 3" unit space for the kit and fasten it to the base rails using two #8-32 screws (item 6). Install the two outer connectors (item 2) and the center connector (item 3) within the mounting barrier, as shown. Fasten the outer connectors to the panel bus with two 1/4"-20 x 1" screws (item 8) and center connector with one 1/4"-20 x 2-1/4" screw (item 10).

CAUTION
Arcing Hazard.
May cause injury or property damage.
Use 1" long screws (item 8) for outer connectors and a 2-1/4" long screw (item 10) for center connectors in Type P3, 7-3/4" deep panelboards to fasten the connector bus.

7. Tighten all screws to the torque values specified on the back of the deadfront.