

SIEMENS

Data Sheet

VBI Heavy Duty Safety Switch

60A, 240V – 600V, Type 12¹

usa.siemens.com/switches

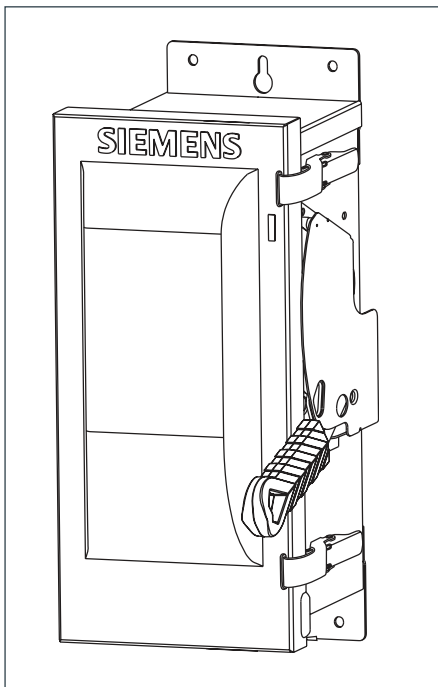

Standards and Ratings

- UL Listed under file #E4776
- Meets UL98 for switches and UL 50 for enclosures
- Meets NEMA Standard KS-1 for enclosed switches
- Meets NEC wire bending space requirements
- Rated 10,000 AIC with Class H fuses or 200,000 AIC with Class R and J fuses
- Rated 100,000 AIC at 600Vdc with Class R or J fuses
- I²t rated (Amps² x Seconds = 200,000)
- 12X overload current rating exceeds 10X industry standard
- Suitable for use as service entrance equipment
- Includes internal shields which meet NEC 2020 230.62 line side barrier requirements

Features

- Quick-make and break switching action
- Double break visible blade design
- Highly visible ON/OFF indication
- Rugged installer friendly enclosure design
- Modular design allows quick and easy replacement of parts
- Front removable lugs which can easily be converted to copper body or compression type lugs
- Defeatable dual cover interlock

Product Specifications

Heavy Duty 60A, 240 - 600V Type 12

General Information

Catalog Number	Volts	Description	Shipping Weight (lbs.)
HF222J	240	2 Pole, 2 Wire Fusible	19
HF322J	240	3 Pole, 3 Wire, Fusible	20
HF262J	600	2 Pole, 2 Wire Fusible	20
HF362J	600	3 Pole, 3 Wire, Fusible	20
HNF262J	600	2 Pole, 2 Wire, Non-Fusible	20
HNF362J	600	3 Pole, 3 Wire, Non-Fusible	19

Horsepower Ratings ² – 240 Volts

Catalog Number	1 Phase, 240V AC		3 Phase, 240V AC		250V DC
	Std	Max	Std	Max	
HF222J	3	10	7½	15	10
HF322J	3	10	7½	15	10

Horsepower Ratings ^{2 3 4} – 600 Volts

Catalog Number	3 Phase, 480V AC		3 Phase, 600V AC		600V DC
	Std	Max	Std	Max	
HF262J	—	— ⁵	—	— ⁵	30
HF362J	15	30	15	50	25
HNF262J	—	— ⁵	—	— ⁵	30
HNF362J ⁶	—	50	—	60	25

Mechanical Lug Wire Range (60/75°C, Cu/Al)

Description	Wire Range
Line, Load Neutral	#12-2 AWG (Al) or #14-2 AWG (Cu)
Ground	#14-4 AWG

Compression Lugs ⁸

Wire Size	Burndy		Thomas-Betts		IlSCO	
	CU Only	CU/AL	CU Only	CU/AL	CU Only	CU/AL
#14-10	—	—	256-30695-1352	60097	—	—
#8	YA8C-L1 BOX YA8C-TC14	YA8CA3	54130 54930BE	60102 61102	—	ACL-8
#6	YA6C-L BOX YA6C	YA6CA1	54105 54905BE	60107 61107	CRB-6 CRB-6L	ACL-6
#4	—	—	54106	61112	CRB-4	—

¹ Also rated 3R/3S for outdoor use.

² Horsepower ratings listed also apply to Design E motors with no derating.

³ Dual horsepower ratings: Std - applies when non-time delay fuses are installed.
Max - applies when time-delay fuses are installed.

⁴ Also rated 10HP at 250V DC.

⁵ Also rated 20HP at 480V and 25HP at 600V, 1 phase.

⁶ Also rated 20HP on 3Ø, 240V AC systems.

⁷ Place "DOOR" at the end of the switch catalog number.

⁸ If compression lugs are used for the neutral, order compression lug neutral barrier kit HCL623.

Accessories

Catalog Number	Description
HA161234	One Normally Open and Closed Auxiliary Switches
HA261234	Two Normally Open and Closed Auxiliary Switches
HA361234	Low Voltage Auxiliary Switch
HG61234	Equipment Ground Lug Kit
HG261234	Isolated Equipment Ground Lug Kit
HP62	Fuse Puller (3 per kit) ((HF222J, HF322J, HF262J, HF362J))
HN623	Neutral Kit
HR612	240 Volt Class R Fuse Clip Kit (3 fuse clips per kit) (HF222J, HF322J)
HR62	600 Volt Class R Fuse Clip Kit (3 fuse clips per kit) (HF262J, HF362J)
HLC612	Copper Lug Kit (9 lugs per kit)
HCL623	Compression Lug Neutral Barrier Kit
SSH100	1.00" Type 12 Hub
SSH125	1.25" Type 12 Hub

Replacement Parts

Catalog Number	Description
HF22	Fusible 240 Volt Line Side Replacement Base (HF222J, HF322J)
HBB22	Fusible 240 Volt Load Side Replacement Base (HF222J, HF322J)
HF62	Fusible 600 Volt Line Side Replacement Base (HF262J, HF362J)
HBB62	Fusible 600 Volt Load Side Replacement Base (HF262J, HF362J)
HNB623	Non-Fusible 600 Replacement Base (HNF262J, HNF362J)
HH6123	Replacement Handle/Handle Guard
HL612	Replacement Lugs (3 lugs per kit)
HM6123	Replacement Mechanism
⁷	Replacement Door

Dimension Drawings

Heavy Duty 60A, 240 - 600V Type 12

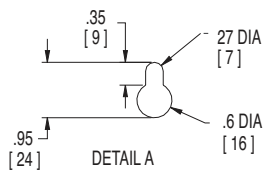
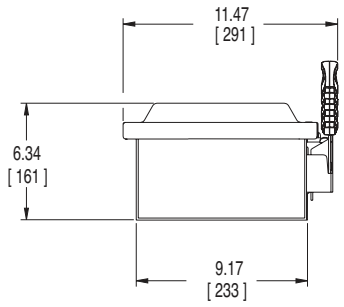
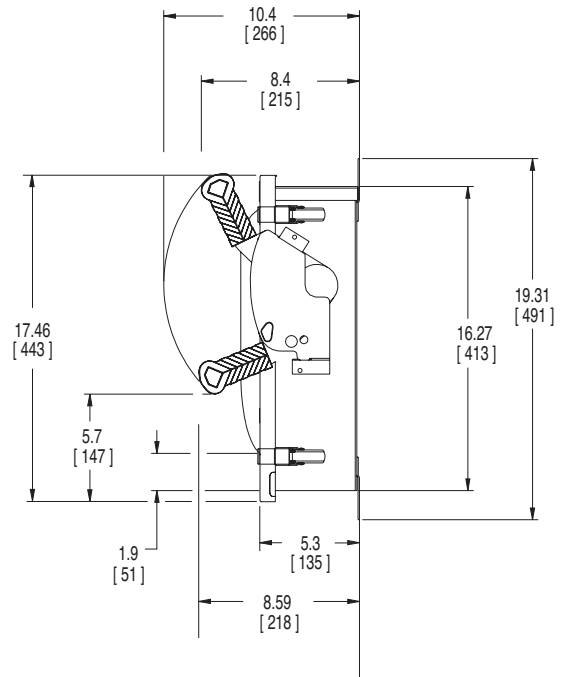
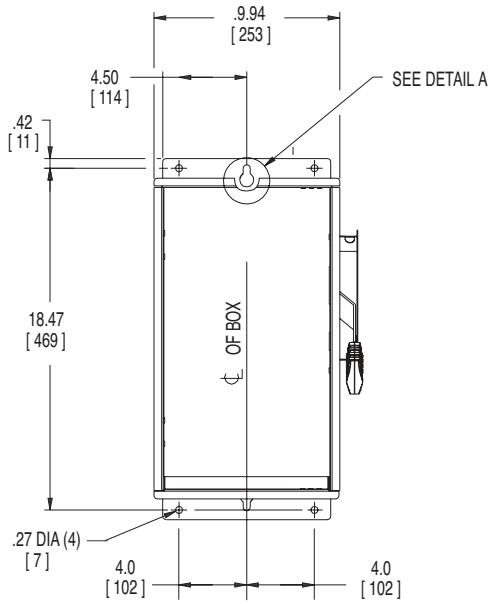

	LINE SIDE WIRE BEND	LOAD SIDE WIRE BEND
240V fused	3.54 (90)	6.07 (154)
600V fused	3.54 (90)	3.57 (91)
Non-Fused	3.54 (90)	8.68 (220)

No knockouts in enclosures.
 Dimensions shown in inches and millimeters ().
 Dimension shown accurate to ± 1/8 inch.

Enclosure: Galvanized Steel
 .054 Thick (17 Gauge)
 Finish: ANSI Grey #61 Paint

Published by
Siemens Industry, Inc. 2021.
 Siemens Industry, Inc.
 3617 Parkway Ln
 Peachtree Corners, GA 30092

For more information, please contact
 our Customer Support Center.
 Phone: 1-800-241-4453
 E-mail: info.us@siemens.com
usa.siemens.com/switches
 Order No.: SSDS-HF612-0521
 Printed in U.S.A.
 © 2021 Siemens Industry, Inc.

The technical data presented in this document is based on an actual case or on as-designed parameters, and therefore should not be relied upon for any specific application and does not constitute a performance guarantee for any projects. Actual results are dependent on variable conditions. Accordingly, Siemens does not make representations, warranties, or assurances as to the accuracy, currency or completeness of the content contained herein. If requested, we will provide specific technical data or specifications with respect to any customer's particular applications. Our company is constantly involved in engineering and development. For that reason, we reserve the right to modify, at any time, the technology and product specifications contained herein.