



POLLO Filter-Technik Bremen / D. Schmolz

Adjusting parameters during operation

Many LOGO! programs use function blocks with parameters. There are several ways to adjust them either directly on the PLC or on an external text display.

The following briefly outlines how values set during commissioning, for example timer or count functions, can be adjusted "live" with LOGO!. >

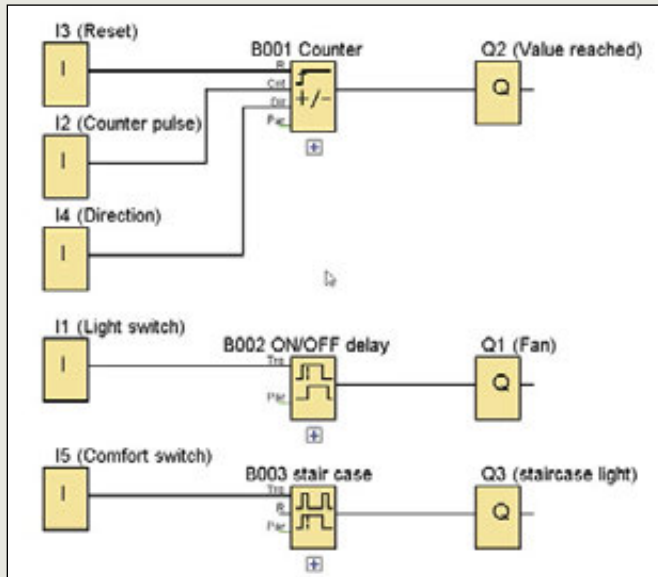

Figure 1

There are several ways to adjust these parameters without changing the actual program, either directly on the LOGO! controller or on an external text display.

The "Set Parameter" function is suitable for service technicians. Displaying the required parameter in the message text is easier for operators, however. In both cases LOGO! remains in RUN mode. So what are the differences and respective advantages?

Our demo program includes three function blocks with parameters. In the following, we will adjust the counter start value in several ways – **Figure 1**.

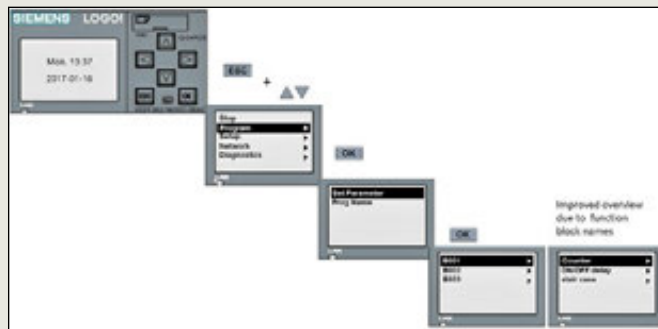

Figure 2

When a LOGO! controller is in RUN mode, the way to exit the start screen (by default the date and time – **Figure 2**) is by pressing the ESC key. This returns you to the main menu, from where you can access the desired function block with the operator control sequence shown.

Select "Program" and "Set Parameter" to open a list of all function blocks that have parameters. If you assign the function blocks informative names during programming, it will be much easier to select the right block later on.



Figure 3

If you make the change from the text display, you must select "LOGO! Settings" (**Figure 3**) as an interim step to reach the main menu.

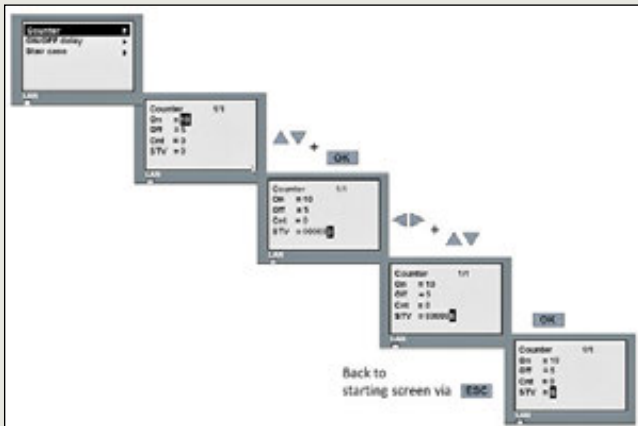

Figure 4

In our example (Figure 4) the “Counter” block is selected with “OK” or the cursor-right button, and all parameters of that block are displayed.

After selecting the desired value – here the start value (STV) – you can adjust it and click OK to confirm.

Then keep pressing the ESC key until the date and time reappear.

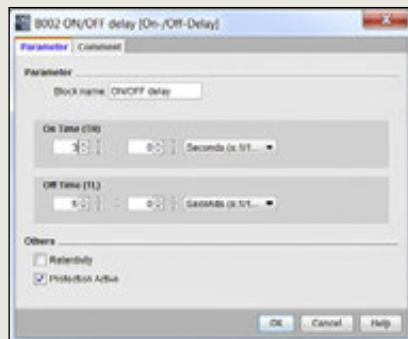

Figure 5

This parameter change can also be made in password-protected programs. If there are function blocks with parameters that the user is not permitted to change, you can lock the individual function block in the block properties by checking the “Protection Active” box – Figure 5.

The function block is then no longer displayed in “Set Parameter” mode.

If the user is permitted to change only one parameter in a block with multiple parameters, there is a smart solution:

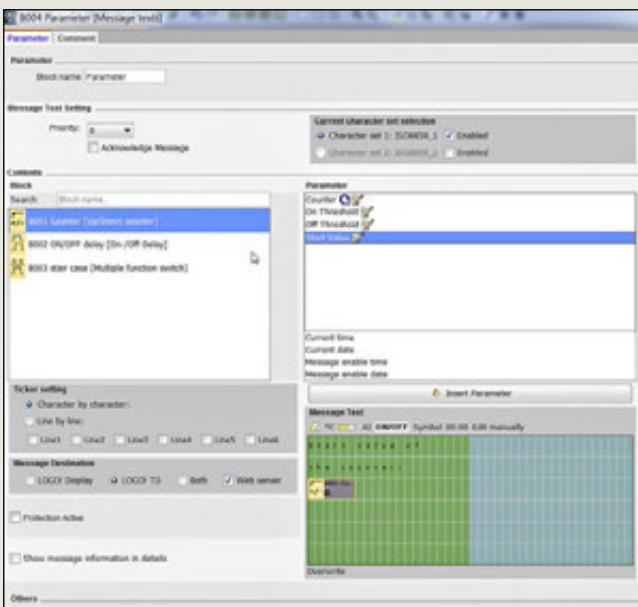

Figure 6

Protection is activated for the block in question, meaning it can no longer be selected in “Set Parameter” mode. The specific parameter required is included in a message text (Figure 6). The value can then simply be adjusted in the message text.



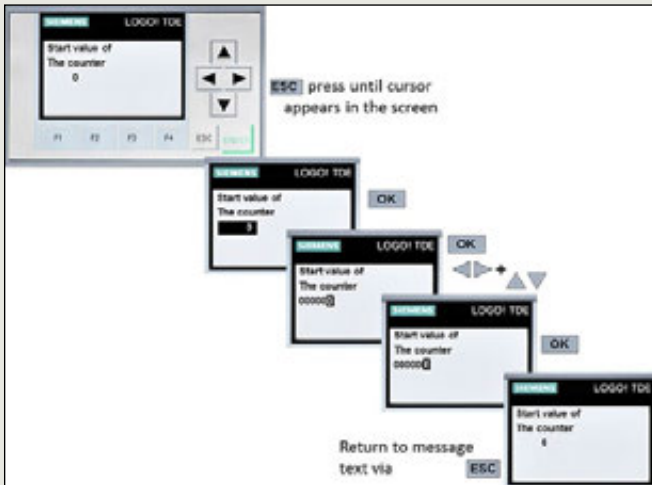

Figure 7

The relevant message text must be active on the display – **Figure 7**. Then keep pressing the ESC key until the cursor is displayed in the text.

⇒ Move the cursor to the corresponding parameter and confirm with OK

⇒ The parameter is then activated and can be adjusted using the cursor buttons

⇒ Confirm with OK. The new value has been set

If a message text displays a parameter that may not be changed, the message text itself can be protected so the value cannot be accessed.

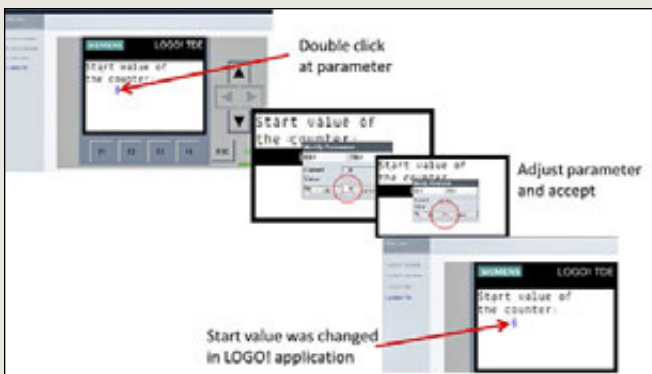

Figure 8

Incidentally, it is possible to change parameters by way of the message text as well as via the web server. Changeable values are displayed in blue on the web server – **Figure 8**.

This means switching times can also be easily adjusted using a smartphone without having to access the control cabinet, as long as the LOGO! is connected to a wireless network and the web server has been enabled. ■