



**USER'S GUIDE**

# **CPU III MODULE A80903 FOR GCP**

**APRIL 2017**

**DOCUMENT NO. SIG-00-15-05  
VERSION A**

Siemens Industry, Inc. Rail Automation  
9568 Archibald Ave., Suite 100,  
Rancho Cucamonga, California 91730  
1-800-793-SAFE

Copyright © 2017 Siemens Industry, Inc.  
All rights reserved

**PRINTED IN U.S.A.**

## PROPRIETARY INFORMATION

Siemens Industry, Inc. has a proprietary interest in the information contained herein and, in some instances, has patent rights in the systems and components described. It is requested that you distribute this information only to those responsible people within your organization who have an official interest.

This document or the information disclosed herein, shall not be reproduced or transferred to other documents or used or disclosed for manufacturing or for any other purpose except as specifically authorized in writing by **Siemens Industry, Inc.**

## TRANSLATIONS

The manuals and product information of Siemens Industry, Inc. are intended to be produced and read in English. Any translation of the manuals and product information are unofficial and can be imprecise and inaccurate in whole or in part. Siemens Industry, Inc. does not warrant the accuracy, reliability, or timeliness of any information contained in any translation of manual or product information from its original official released version in English and shall not be liable for any losses caused by such reliance on the accuracy, reliability, or timeliness of such information. Any person or entity that relies on translated information does so at his or her own risk.

## WARRANTY INFORMATION

Siemens Industry, Inc. warranty policy is as stated in the current Terms and Conditions of Sale document. Warranty adjustments will not be allowed for products or components which have been subjected to abuse, alteration, improper handling or installation, or which have not been operated in accordance with Seller's instructions. Alteration or removal of any serial number or identification mark voids the warranty.

## SALES AND SERVICE LOCATIONS

Technical assistance and sales information on **Siemens Industry, Inc.** products may be obtained at the following locations:

SIEMENS INDUSTRY, INC. RAIL AUTOMATION  
2400 NELSON MILLER PARKWAY  
LOUISVILLE, KENTUCKY 40223  
TELEPHONE: (502) 618-8800  
FAX: (502) 618-8810  
SALES & SERVICE: (800) 626-2710  
WEB SITE: [www.siemens.com/rail-automation](http://www.siemens.com/rail-automation)

SIEMENS INDUSTRY, INC. RAIL AUTOMATION  
939 S. MAIN STREET  
MARION, KENTUCKY 42064  
TELEPHONE: (270) 918-7800  
CUSTOMER SERVICE: (800) 626-2710  
TECHNICAL SUPPORT: (800) 793-7233  
FAX: (270) 918-7830

## FCC RULES COMPLIANCE

The equipment covered in this manual has been tested and found to comply with the limits for a Class A digital device, pursuant to part 15 of the FCC Rules. These limits are designed to provide reasonable protection against harmful interference when the equipment is operated in a commercial environment. This equipment generates, uses, and can radiate radio frequency energy and, if not installed and used in accordance with the instruction manual, may cause harmful interference to radio communications. Operation of this equipment in a residential area is likely to cause harmful interference in which case the user will be required to correct the interference at his/her own expense.

**DOCUMENT HISTORY**

<b>Version</b>	<b>Release Date</b>	<b>Sections Changed</b>	<b>Details of Change</b>
A	APR 2017		Initial Release

## Table of Contents

Section	Title	Page
PROPRIETARY INFORMATION .....		ii
TRANSLATIONS.....		ii
WARRANTY INFORMATION .....		ii
SALES AND SERVICE LOCATIONS .....		ii
FCC RULES COMPLIANCE .....		ii
DOCUMENT HISTORY .....		.iii
NOTES, CAUTIONS, AND WARNINGS.....		xii
ELECTROSTATIC DISCHARGE (ESD) PRECAUTIONS.....		xiii
GLOSSARY .....		xiv
SECTION 1 - INTRODUCTION .....		1-1
1.0 INTRODUCTION.....		1-1
1.1 GENERAL DESCRIPTION.....		1-2
1.2 ORDERING INFORMATION.....		1-3
SECTION 2 – CPU III MODULE OPERATION.....		1-1
2.0 CPU III MODULE OPERATION.....		2-1
2.1 INDICATORS, CONTROLS, AND CONNECTORS.....		2-1
2.1.1 CPU III Local User Interface.....		2-3
2.1.1.1 Using the Select and Navigate Push Buttons.....		2-3
2.1.1.2 CPU III Local User for GCP .....		2-4
SECTION 3 – CPU III WEB USER INTERFACE (WEB UI) .....		2-1
3.0 CPU III WEB USER INTERFACE (WEB UI).....		3-1
3.1 CPU III WEB UI SCREEN DISPLAYS FOR GCP .....		3-1
3.1.1 CPU III Web UI System View .....		3-4
3.1.1.1 CPU III Web UI - System Views – Track/PSO Menu .....		3-5
3.1.1.2 CPU III Web UI - System Views – SSCC Menu .....		3-12
3.1.1.3 CPU III Web UI - System Views – Check Numbers .....		3-17
3.1.2 CPU III Web UI – GCP5000 Configuration.....		3-18
3.1.2.1 CPU III Web UI – GCP5000 Configuration – Setup Wizard.....		3-18
3.1.2.2 CPU III Web UI - GCP5000 Configuration – Site Configuration.....		3-20
3.1.2.3 CPU III Web UI – GCP5000 Configuration – Basic Configuration .....		3-21
3.1.2.4 CPU III Web UI – GCP5000 Configuration – GCP and Island Programming .....		3-22
3.1.2.5 CPU III Web UI – GCP5000 Configuration – Logic Programming .....		3-23
3.1.2.6 CPU III Web UI – GCP5000 Configuration – Advanced Programming.....		3-24
3.1.2.7 CPU III Web UI – GCP5000 Configuration – SSCC Programming.....		3-24
3.1.2.8 CPU III Web UI – GCP5000 Configuration – Input/Output Assignments.....		3-25
3.1.2.9 CPU III Web UI – GCP5000 Configuration – CP Programming.....		3-26

3.1.3	CPU III Web UI – GCP4000 Configuration.....	3-32
3.1.3.1	CPU III Web UI – GCP4000 Configuration – TEMPLATE Programming.....	3-33
3.1.3.2	CPU III Web UI – GCP4000 Configuration – BASIC: Configuration .....	3-34
3.1.3.3	CPU III Web UI – GCP4000 Configuration – PREDICTORS Configuration .....	3-35
3.1.3.4	CPU III Web UI – GCP4000 Configuration – GCP Programming .....	3-36
3.1.3.5	CPU III Web UI – GCP4000 Configuration – Island Programming .....	3-36
3.1.3.6	CPU III Web UI – GCP4000 Configuration – AND Tracks Configuration.....	3-37
3.1.3.7	CPU III Web UI – GCP4000 Configuration – ADVANCED Programming.....	3-37
3.1.3.8	CPU III Web UI – GCP4000 Configuration – SSCC Programming.....	3-38
3.1.3.9	CPU III Web UI – GCP4000 Configuration – SEAR Programming.....	3-38
3.1.3.10	CPU III Web UI – GCP4000 Configuration – SITE Programming.....	3-39
3.1.3.11	CPU III Web UI – GCP4000 Configuration – CP Programming Menu.....	3-41
3.1.3.12	CPU III Web UI – GCP4000 Configuration – CP Programming - Security.....	3-43
3.1.3.13	CPU III Web UI – GCP4000 Configuration – CP Programming – Web Server.....	3-43
3.1.3.14	CPU III Web UI – GCP4000 Configuration – CP Programming – Set to Default.....	3-44
3.1.4	CPU III Web UI – GCP Calibration and Adjustment.....	3-45
3.1.4.1	CPU III Web UI – Calibration and Adjustment – Track/PSO .....	3-46
3.1.4.2	CPU III Web UI – Calibration and Adjustment – SSCC.....	3-51
3.1.5	CPU III Web UI – GCP Status Monitor .....	3-55
3.1.6	CPU III Web UI – Reports & Logs .....	3-64
3.1.6.1	CPU III Web UI – Reports & Logs – Log Options.....	3-64
3.1.6.2	CPU III Web UI – Reports & Logs – Log Options - Basic.....	3-65
3.1.6.3	CPU III Web UI – Reports & Logs – Log Options - Advanced .....	3-66
3.1.6.4	CPU III Web UI – Reports & Logs – Log Options - Trace .....	3-66
3.1.6.5	CPU III Web UI – Reports & Logs – CP Status Log.....	3-67
3.1.6.6	CPU III Web UI – Reports & Logs – CP Status Log - Train Log .....	3-67
3.1.6.7	CPU III Web UI – Reports & Logs – CP Status Log - Maintenance Log.....	3-68
3.1.6.8	CPU III Web UI – Reports & Logs – CP Status Log - Train Summary Log.....	3-68
3.1.6.9	CPU III Web UI – Reports & Logs – CP Status Log - Non-Vital CPU Log.....	3-69
3.1.6.10	CPU III Web UI – Reports and Logs – Train History .....	3-70
3.1.6.11	CPU III Web UI – Reports and Logs – Maintenance Log.....	3-70
3.1.6.12	CPU III Web UI – Reports and Logs – Reports .....	3-71
3.1.6.13	CPU III Web UI – Reports and Logs – Reports – Configuration Report .....	3-72
3.1.6.14	CPU III Web UI – Reports and Logs – Reports – Program Report.....	3-73
3.1.6.15	CPU III Web UI – Reports & Logs – Reports – Min Program Steps Report.....	3-74
3.1.6.16	CPU III Web UI – Reports & Logs – Reports – Template Report.....	3-75
3.1.6.17	CPU III Web UI – Reports & Logs – Reports – Version Report .....	3-76
3.1.6.18	CPU III Web UI – Reports & Logs – EZ/EX Recording .....	3-77
3.1.6.19	CPU III Web UI – Reports & Logs – EZ/EX Recording - Using EZ & EX Files .....	3-78
3.1.6.20	CPU III Web UI – Reports & Logs – Track Data .....	3-79
3.1.6.21	CPU III Web UI – Reports & Logs – VLP/IO Card Logs.....	3-80
3.1.6.22	CPU III Web UI – Reports & Logs – Check Numbers .....	3-81
3.1.7	CPU III Web UI – Software Update .....	3-82
3.1.7.1	CPU III Web UI – Software Updates – Configuration – Uploading.....	3-83
3.1.7.2	CPU III Web UI – Software Updates – Configuration – Downloading.....	3-84

3.1.7.3	CPU III Web UI – Software Updates – CP MEF .....	3-84
3.1.7.4	CPU III Web UI – Software Updates – VLP - MEF .....	3-85
3.1.7.5	CPU III Web UI – Software Updates – VLP - MCF .....	3-85
3.1.7.6	CPU III Web UI – Software Updates – VLP - MCFCRC .....	3-86
3.1.7.7	CPU III Web UI – Software Updates – VLP – Clear ECD .....	3-86
3.1.7.8	CPU III Web UI – Software Updates – VLP – Clear CIC .....	3-87
3.1.7.9	CPU III Web UI – Software Updates – VLP – Reset VLP .....	3-88
3.1.7.10	CPU III Web UI – Software Updates – Vital IO Module .....	3-89
3.1.7.11	CPU III Web UI – Software Updates – Vital IO – Download Console Log .....	3-91
3.1.8	CPU III Web UI - Diagnostics .....	3-92
3.1.9	CPU III Web UI – Unlock Procedure .....	3-93
3.1.9.1	CPU III Web UI – Unlocking Procedure – Reset VLP Module .....	3-94
SECTION 4 – USING CPU III WITH A DISPLAY MODULE .....		3-1
4.0	USING CPU III WITH A DISPLAY MODULE .....	4-1
4.1	GENERAL .....	4-1
4.1.1	System View .....	4-1
4.1.2	Configuration .....	4-1
4.1.2.1	CP Programming – Laptop Port .....	4-1
4.1.2.2	CP Programming – Web Server .....	4-1
4.1.2.3	CP Programming – Set to Default .....	4-1
4.1.3	Calibration & Adjustment .....	4-1
4.1.4	Status Monitor .....	4-1
4.1.4.1	Ethernet Status .....	4-1
4.1.4.2	Route Table .....	4-1
4.1.4.3	Statistics .....	4-2
4.1.5	Reports & Logs .....	4-2
4.1.5.1	CP Status Log .....	4-2
4.1.5.2	Train History .....	4-2
4.1.5.3	Maintenance Log .....	4-2
4.1.5.4	Reports .....	4-2
4.1.5.5	EZ/EX Recording .....	4-2
4.1.5.6	Track Data .....	4-2
4.1.5.7	VLP/IO Card Logs .....	4-2
4.1.5.8	Check Numbers .....	4-2
4.1.6	Software Updates .....	4-2
4.1.6.1	Configuration .....	4-2
4.1.6.2	CP MEF .....	4-2
4.1.6.3	VLP .....	4-3
4.1.6.4	Vital IO Module .....	4-3
4.1.7	Diagnostics .....	4-3
4.1.8	GCP4000 .....	4-3
4.1.9	GCP5000 .....	4-4

SECTION 5 – CPU III SETUP – EXISTING GCP4000/5000.....4-1  
5.0 CPU III – GCP4000/5000.....5-1  
5.1 GENERAL.....5-1  
5.2 NEW GCP4000/5000 INSTALLATION APPLICATION (NO DISPLAY MODULE).....5-2

## List of Figures

Section	Title	Page
Figure 1-1	A80903 CPU III Module .....	1-2
Figure 2-1	CPU III Indicators, Controls, and Connectors .....	2-2
Figure 3-1	Unsecure Connection Warning.....	3-2
Figure 3-2	CPU III Web UI - Log In Screen .....	3-2
Figure 3-3	CPU III Web UI - Opening Screen – System Views or Diagnostics .....	3-3
Figure 3-4	CPU III Web UI – System View Menus .....	3-4
Figure 3-5	CPU III Web UI – System View Module Sub-menus .....	3-4
Figure 3-6	CPU III Web UI – System View – Track/PSO Detail View .....	3-5
Figure 3-7	CPU III Web UI – System View – Track/PSO Diagnostics.....	3-5
Figure 3-8	CPU III Web UI – System View – Track/PSO Diagnostics - Icons.....	3-6
Figure 3-9	CPU III Web UI – System View – Track/PSO Track Setup.....	3-6
Figure 3-10	CPU III Web UI – System View – Track/PSO Calibration .....	3-7
Figure 3-11	CPU III Web UI – System View – SSCC Remote Setup.....	3-9
Figure 3-12	CPU III Web UI – System View – Track/PSO - Remote Setup Request.....	3-10
Figure 3-13	CPU III Web UI – System View – Track/PSO - Remote Setup Information.....	3-10
Figure 3-14	CPU III Web UI – System View – Track/PSO – Out Of Service Screen .....	3-12
Figure 3-15	CPU III Web UI – System View – SSCC Diagnostics .....	3-12
Figure 3-16	CPU III Web UI – System View – SSCC Diagnostics - Icons .....	3-13
Figure 3-17	CPU III Web UI – System View – SSCC Lamp Adjustment.....	3-13
Figure 3-18	CPU III Web UI – System View – SSCC Test.....	3-14
Figure 3-19	CPU III Web UI – System View – SSCC Test Options.....	3-15
Figure 3-20	CPU III Web UI – System View – Check Numbers .....	3-17
Figure 3-21	CPU III Web UI – Configuration Menu .....	3-18
Figure 3-22	CPU III Web UI – GCP5000 Configuration – Setup Wizard.....	3-18
Figure 3-23	CPU III Web UI – GCP5000 Configuration – Setup Wizard Screens.....	3-19
Figure 3-24	CPU III Web UI – GCP5000 Configuration – Site Configuration.....	3-20
Figure 3-25	CPU III Web UI – GCP5000 Configuration – Basic Configuration .....	3-21
Figure 3-26	CPU III Web UI – GCP5000 Config – GCP and Island Programming Menu .....	3-22
Figure 3-27	CPU III Web UI – GCP5000 Configuration– Logic Programming Menu.....	3-23
Figure 3-28	CPU III Web UI – GCP5000 Configuration – Advanced Programming Menu.....	3-24
Figure 3-29	CPU III Web UI – GCP5000 Configuration – SSCC Programming Menu.....	3-24
Figure 3-30	CPU III Web UI – GCP5000 Configuration – Input/Output Assignments Menu.....	3-25
Figure 3-31	CPU III Web UI – GCP5000 Configuration – CP Programming Menu.....	3-26
Figure 3-32	CPU III Web UI – GCP5000 Configuration – CP Programming – Laptop Port.....	3-27
Figure 3-33	CPU III Web UI – GCP5000 Config – CP Programming – Diagnostic Logging .....	3-28
Figure 3-34	CPU III Web UI – GCP5000 Config – CP Programming –Logging Verbosity .....	3-28
Figure 3-35	CPU III Web UI – GCP5000 Config – CP Programming –Security.....	3-30
Figure 3-36	CPU III Web UI – GCP5000 Config – CP Programming –Web Server.....	3-30
Figure 3-37	CPU III Web UI – GCP5000 Configuration – CP Programming – Set to Default.....	3-31
Figure 3-38	CPU III Web UI – GCP4000 Configuration Menu.....	3-32
Figure 3-39	CPU III Web UI – GCP4000 Configuration Menu – Navigation Buttons .....	3-32
Figure 3-40	CPU III Web UI – GCP4000 Configuration – TEMPLATE Programming.....	3-33
Figure 3-41	CPU III Web UI – GCP4000 Config – BASIC: Config – Module Configuration.....	3-34
Figure 3-42	CPU III Web UI – GCP4000 Config – PREDICTORS Configuration .....	3-35
Figure 3-43	CPU III Web UI – GCP4000 Config – GCP Programming .....	3-36
Figure 3-44	CPU III Web UI – GCP4000 Config – ISLAND Programming.....	3-36
Figure 3-45	CPU III Web UI – GCP4000 Config – AND Tracks Config.....	3-37
Figure 3-46	CPU III Web UI – GCP4000 Config – ADVANCED Programming Menu.....	3-37
Figure 3-47	CPU III Web UI – GCP4000 Config – SSCC Programming .....	3-38
Figure 3-48	CPU III Web UI – GCP4000 Config – SEAR Programming .....	3-38
Figure 3-49	CPU III Web UI – GCP4000 Config – SITE Programming.....	3-39
Figure 3-50	CPU III Web UI – GCP4000 Config – CP Programming.....	3-41



Figure 3-51	CPU III Web UI – GCP4000 Config – CP Programming – Laptop Port .....	3-41
Figure 3-52	CPU III Web UI – GCP4000 Config – CP Prog – Log Setup – Diagnostic Log .....	3-42
Figure 3-53	CPU III Web UI – GCP4000 Config – CP Prog – Log Setup – Verbosity .....	3-42
Figure 3-54	CPU III Web UI – GCP4000 Config – CP Prog – Security .....	3-43
Figure 3-55	CPU III Web UI – GCP4000 Config – CP Prog – Web Server .....	3-43
Figure 3-56	CPU III Web UI – GCP4000 Config – CP Prog – Set to Default .....	3-44
Figure 3-57	CPU III Web UI – Calibration & Adjustment Menu .....	3-45
Figure 3-58	CPU III Web UI – Calibration & Adjustment – Track/PSO – Track Setup .....	3-46
Figure 3-59	CPU III Web UI – Calibration & Adjustment – Track/PSO – Calibration .....	3-47
Figure 3-60	CPU III Web UI – Calibration & Adjustment – Track/PSO – Start Calibration .....	3-47
Figure 3-61	CPU III Web UI – Calibration & Adjustment – Track/PSO – Calibration Fail .....	3-48
Figure 3-62	CPU III Web UI – Calib & Adjustment – Track/PSO – Calibration Bypass .....	3-48
Figure 3-63	CPU III Web UI – Calibration & Adjustment – Track/PSO – Calibration Edit .....	3-49
Figure 3-64	CPU III Web UI – Calibration & Adjustment – Track/PSO – Remote Setup .....	3-50
Figure 3-65	CPU III Web UI – Calibration & Adjustment – SSCC - Diagnostics .....	3-51
Figure 3-66	CPU III Web UI – Calibration & Adjustment – SSCC – Lamp Adjustment .....	3-51
Figure 3-67	CPU III Web UI – Calibration & Adjustment – SSCC – SSCC Tests .....	3-52
Figure 3-68	CPU III Web UI – Calibration & Adjustment – SSCC – SSCC Test Screens .....	3-53
Figure 3-69	CPU III Web UI – Calibration & Adjustment – Track/PSO – Remote Setup .....	3-54
Figure 3-70	CPU III Web UI – Status Monitor Menu .....	3-55
Figure 3-71	CPU III Web UI – Status Monitor Menu – IO View – Vital View .....	3-55
Figure 3-72	CPU III Web UI – Status Monitor Menu – Logical View .....	3-56
Figure 3-73	CPU III Web UI – Status Monitor Menu – Logical View – Logical View Detail .....	3-56
Figure 3-74	Logic View Troubleshooting Example .....	3-57
Figure 3-75	Logic View Example with a Timed Logic Switch .....	3-58
Figure 3-76	System States Logic Detail View .....	3-59
Figure 3-77	CPU III Web UI – Status Monitor – Module IO View .....	3-60
Figure 3-78	CPU III Web UI – Status Monitor Menu – Comm View .....	3-60
Figure 3-79	CPU III Web UI – Status Monitor Menu – Logic State .....	3-61
Figure 3-80	CPU III Web UI – Status Monitor Menu – Ethernet Status .....	3-61
Figure 3-81	CPU III Web UI – Status Monitor Menu – Route Table Status .....	3-62
Figure 3-82	CPU III Web UI – Status Monitor Menu – Statistics .....	3-62
Figure 3-83	CPU III Web UI – Status Monitor – Statistics – ATCS Time SIO Echelon® .....	3-63
Figure 3-84	CPU III Web UI – Reports and Logs Menu .....	3-64
Figure 3-85	CPU III Web UI – Reports and Logs – Log Options .....	3-64
Figure 3-86	CPU III Web UI – Reports and Logs – Basic Log .....	3-65
Figure 3-87	CPU III Web UI – Reports and Logs – Basic Log Search Features .....	3-65
Figure 3-88	CPU III Web UI – Reports and Logs – Advanced Log & Filters .....	3-66
Figure 3-89	CPU III Web UI – Reports and Logs – Trace Log .....	3-66
Figure 3-90	CPU III Web UI – Reports and Logs – CP Status Log .....	3-67
Figure 3-91	CPU III Web UI – Reports and Logs – CP Status Log – Train Log .....	3-67
Figure 3-92	CPU III Web UI – Reports and Logs – CP Status Log – Maintenance Log .....	3-68
Figure 3-93	CPU III Web UI – Reports and Logs – CP Status Log – Train Summary Log .....	3-68
Figure 3-94	CPU III Web UI – Reports and Logs – CP Status Log – Non-Vital CPU Log .....	3-69
Figure 3-95	CPU III Web UI – Reports and Logs – Train History Log .....	3-70
Figure 3-96	CPU III Web UI – Reports and Logs – Maintenance Log .....	3-70
Figure 3-97	CPU III Web UI – Reports and Logs – Reports .....	3-71
Figure 3-98	CPU III Web UI – Reports and Logs – Reports – Configuration Report .....	3-72
Figure 3-99	CPU III Web UI – Reports and Logs – Reports – Program Report .....	3-73
Figure 3-100	CPU III Web UI – Reports and Logs – Reports – Min Program Steps .....	3-74
Figure 3-101	CPU III Web UI – Reports and Logs – Reports – Template Report .....	3-75
Figure 3-102	CPU III Web UI – Reports and Logs – Reports - Version Report .....	3-76
Figure 3-103	CPU III Web UI – Reports and Logs – Reports – EZ/EX Recording .....	3-77
Figure 3-104	CPU III Web UI – Reports & Logs – Reports – EZ/EX Data File Layout .....	3-78
Figure 3-105	CPU III Web UI – Reports & Logs – Reports – Prime, EZ, & EX Chart .....	3-78
Figure 3-106	CPU III Web UI – Reports and Logs – Reports – Track Data .....	3-79

Figure 3-107	CPU III Web UI – Reports and Logs – Reports – VLP/IO Card Logs .....	3-80
Figure 3-108	CPU III Web UI – Reports and Logs – Reports – Check Numbers.....	3-81
Figure 3-109	CPU III Web UI – Software Updates Menu .....	3-82
Figure 3-110	CPU III Web UI – Software Updates – Upload Configuration .....	3-83
Figure 3-111	CPU III Web UI – Software Updates – Download Configuration PAC File .....	3-84
Figure 3-112	CPU III Web UI – Software Updates – Update CP MEF .....	3-84
Figure 3-113	CPU III Web UI – Software Updates – Update MEF .....	3-85
Figure 3-114	CPU III Web UI – Software Updates – Update MCF .....	3-85
Figure 3-115	CPU III Web UI – Software Updates – Update MCFCRC Value.....	3-86
Figure 3-116	CPU III Web UI – Software Updates – Clear ECD .....	3-86
Figure 3-117	CPU III Web UI – Software Updates – Clear CIC .....	3-87
Figure 3-118	CPU III Web UI – Software Updates – Reset VLP .....	3-88
Figure 3-119	CPU III Web UI – Software Updates – Vital IO Module Install Software.....	3-89
Figure 3-120	Serial Cable Connection for Module Software Updates .....	3-90
Figure 3-121	CPU III Web UI – Software Updates – Vital IO Module Download Console Log .....	3-91
Figure 3-122	CPU III Web UI – Diagnostics - Diagnostics Screen and Icons .....	3-92
Figure 3-123	CPU III Web UI – Unlock Procedure .....	3-93
Figure 3-124	CPU III Web UI – Unlocking Procedure - Reset VLP Module .....	3-94
Figure 5-1	System View Screen .....	5-1
Figure 5-2	Using CPU III Push-Buttons on SGCP/MS4000 .....	5-2

## List of Tables

Section	Title	Page
Table 2-1	CPU III Indicators, Controls, and Connectors.....	2-1
Table 2-2	LED Indications.....	2-4
Table 2-3	CPU III GCP Display Messages .....	2-5

## NOTES, CAUTIONS, AND WARNINGS

Throughout this manual, notes, cautions, and warnings are frequently used to direct the reader's attention to specific information. Use of the three terms is defined as follows:

### **WARNING**

**WARNING**  
INDICATES A POTENTIALLY HAZARDOUS SITUATION WHICH, IF NOT AVOIDED, COULD RESULT IN DEATH OR SERIOUS INJURY. WARNINGS ALWAYS TAKE PRECEDENCE OVER NOTES, CAUTIONS, AND ALL OTHER INFORMATION.

### **CAUTION**

**CAUTION**  
REFERS TO PROPER PROCEDURES OR PRACTICES WHICH IF NOT STRICTLY OBSERVED, COULD RESULT IN A POTENTIALLY HAZARDOUS SITUATION AND/OR POSSIBLE DAMAGE TO EQUIPMENT. CAUTIONS TAKE PRECEDENCE OVER NOTES AND ALL OTHER INFORMATION, EXCEPT WARNINGS.

### **NOTE**

**NOTE**  
Generally used to highlight certain information relating to the topic under discussion.

If there are any questions, contact Siemens Industry, Inc. Application Engineering.

## **ELECTROSTATIC DISCHARGE (ESD) PRECAUTIONS**

Static electricity can damage electronic circuitry, particularly low voltage components such as the integrated circuits commonly used throughout the electronics industry. Therefore, procedures have been adopted industry-wide which make it possible to avoid the sometimes invisible damage caused by electrostatic discharge (ESD) during the handling, shipping, and storage of electronic modules and components. Siemens Industry, Inc. has instituted these practices at its manufacturing facility and encourages its customers to adopt them as well to lessen the likelihood of equipment damage in the field due to ESD. Some of the basic protective practices include the following:

- Ground yourself before touching card cages, assemblies, modules, or components.
- Remove power from card cages and assemblies before removing or installing modules.
- Remove circuit boards (modules) from card cages by the ejector lever only. If an ejector lever is not provided, grasp the edge of the circuit board but avoid touching circuit traces or components.
- Handle circuit boards by the edges only.
- Never physically touch circuit board or connector contact fingers or allow these fingers to come in contact with an insulator (e.g., plastic, rubber, etc.).
- When not in use, place circuit boards in approved static-shielding bags, contact fingers first. Remove circuit boards from static-shielding bags by grasping the ejector lever or the edge of the board only. Each bag should include a caution label on the outside indicating static-sensitive contents.
- Cover workbench surfaces used for repair of electronic equipment with static dissipative workbench matting.
- Use integrated circuit extractor/insertor tools designed to remove and install electrostatic-sensitive integrated circuit devices such as PROM's (OK Industries, Inc., Model EX-2 Extractor and Model MOS-40 Insertor (or equivalent) are highly recommended).
- Utilize only anti-static cushioning material in equipment shipping and storage containers.

For information concerning ESD material applications, please contact the Technical Support Staff at 1-800-793-7233. ESD Awareness Classes and additional ESD product information are also available through the Technical Support Staff.

## GLOSSARY

TERM	DESCRIPTION
AAR:	Association of American Railroads – An organization that establishes uniformity and standardization among different railroad systems.
ACSES:	Advanced Civil Speed Enforcement System
AREMA:	American Railway Engineering and Maintenance-of-way Association
Aspect:	(Signal Aspect) The appearance of a fixed signal conveying an indication as viewed from the direction of an approaching train. A cab signal conveying an indication as viewed by an observer in the cab.
ATCS:	Advanced Train Control System – An industry standard used in equipment communications.
BCM:	Base Control Module
BCP:	Base Communication Package, or Base Station
Boot:	Startup sequence for the microprocessor. On the GEO system this can be accomplished by removing then reseating the CPU module or by pulling the 30 A chassis fuse for a few seconds.
CAD:	Computer Aided Dispatch. An automated system for processing dispatch business and automating many of the tasks typically performed by a dispatcher. Abbreviated CAD (not to be confused with computer-aided design which is also known as CAD) is application software with numerous features and functions.
CDL:	Control Descriptor Language – The programming language used by application engineers to customize operation, settings, and behavior.
CDMA:	Code Division Multiple Access. A protocol used in cellular telephony.
Checksum:	A simple way to protect the integrity of data by detecting errors in data that are sent through space (telecommunications) or time (storage). It works by adding up the basic components of a message, typically the asserted bits, and storing the resulting value. Anyone can later perform the same operation on the data, compare the result to the authentic checksum and (assuming that the sums match) conclude that the message was most likely not corrupted.
CETC:	Centralized Electrification & Train Control
Configuration PAC File:	Configuration Package file. This can be created offline using the DT / OCCN or down loaded from the GCP. When changes are made to the default settings in the MCF (Module Configuration File), the custom settings are maintained in the configuration file.
CPU III:	Next Generation GCP central processing unit (CPU) module.
CRC:	Cyclical Redundancy Check – Used to determine that data has not been corrupted.
CTC:	Centralized Traffic Control. This is also known as CAD for Computer Aided Dispatch. This is the system in the office used to control and monitor the railroad signaling system.
DATAGRAM:	In general, any ATCS packet. Several types of datagrams are defined for specific functions within an ATCS environment.
dB:	Decibels
dB <sub>i</sub>	Abbreviation for decibels referenced to an isotropic (unipole) antenna.
dB <sub>m</sub>	Abbreviation for decibels above (or below) one milliwatt.
DC offsets:	Condition in which one rail is kept at one voltage relative to the other

<b>TERM</b>	<b>DESCRIPTION</b>
	even when the track circuit is disconnected.
Debounce:	The amount of time an input must remain constant to be considered a valid input. Debounce prevents random spikes of electrical energy from energizing an input.
DIAG.:	Diagnostic
DNS:	Domain Name Server
DOT Number:	Department of Transportation crossing inventory number assigned to every highway-railroad crossing. The number consists of six numbers with an alpha suffix.
Drop Delay	An internal delay time between when a function is ordered off and when it actually de-energizes.
DSU:	Data Service Unit
DT:	Diagnostic Terminal - Siemens' PC-based diagnostic software.
DTMF:	Dual Tone Multi-Frequency - The tones on a telephone or radio keypad.
ECD:	External Configuration Device – The non-volatile memory device used for storing the module configuration file.
Echelon®:	A Local Area Network, LAN, used by Siemens equipment.
EEPROM:	Electrically Erasable Programmable Read-Only Memory. A type of non-volatile memory used in computers and other electronic devices to store small amounts of data that must be saved when power is removed. When larger amounts of static data are to be stored, a specific type of EEPROM called a flash memory is used.
ELS:	Serial Link extension board
EMP:	Edge Messaging Protocol. A common message format used for edge integration. Examples of integration edges are wireless transports and various messaging systems that may be used by the various railroads (e.g., using EMP to communicate between mobile applications and back office applications using wireless communications). EMP defines the message format, header, and operating rules which facilitate interoperable message transmission, reception, decoding, and routing.
Firmware:	Software saved in ROM within a module and moved into main memory RAM for runtime use when the system is powered up.
FRA:	Federal Railroad Administration. The purpose of FRA is to: promulgate and enforce rail safety regulations; administer railroad assistance programs; conduct research and development in support of improved railroad safety and national rail transportation policy; and consolidate government support of rail transportation activities.
GCP:	Grade Crossing Predictor – A train detection device used as part of a highway-railroad grade crossing warning system to provide a relatively uniform warning time.
GEO®:	Geographic Signaling System - GEO® is vital microprocessor-controlled signaling equipment manufactured by Safetran Systems Corporation. It monitors and controls switches, signals, and relays at wayside locations on the railroad.
GENI (F):	Genisys Field Protocol
GENI (O):	Genisys Office Protocol

<b>TERM</b>	<b>DESCRIPTION</b>
GFT:	Ground Fault Tester – An optional external device connected to the Echelon LAN that constantly monitors up to two batteries for ground faults and indicates battery status.
GMT:	The time as measured on the prime meridian running through Greenwich, England: used in England and as a standard of calculation elsewhere. Also called Greenwich Mean Time, Greenwich Civil Time, Universal Time
GPS:	Global Positioning System.
HMAC:	Keyed-Hash Message Authentication Code. A type of message authentication code (MAC) calculated using a specific algorithm involving a cryptographic hash function in combination with a secret key.
HS:	Home Signal
Hz:	Hertz – Common reference for cycles per second or flashes per second.
Interconnection:	The electrical connection between the railroad active warning system and the traffic signal controller for the purpose of preemption.
IP:	Internet Protocol - ISO Model Layer 3 (network) protocol that performs proper routing of packets.
ITC:	Interoperable Train Control
ITCM:	Interoperable Train Control Message.
Interlocking:	An automatic or manual arrangement of signals and appliances so interconnected that their movements must succeed each other in proper sequence and for which interlocking rules are in effect.
IO or I/O:	Input/Output
kHz:	Kilohertz – 1000 Hz or 1000 cycles per second.
LAN:	Local Area Network – A limited network where the data transfer medium is generally wires or cable.
LCP:	Local Control Panel – A control and display interface device that allows field personnel to perform maintenance and troubleshooting procedures at a location.
LED:	Light-Emitting-Diode - A solid-state indicator.
LOD:	Light Out Detector - A device that monitors current flowing in a circuit such as a signal light, switch, etc., for the purpose of detecting a fault condition in the circuit.
LUI:	Local User Interface – Refers to the character display and keypad on the front panel of Safetran equipment.
MCF:	Module Configuration File
MEF:	Module Executable File
Module:	Physical package including PCBs and input/output terminals for connecting to external devices and equipment.
NTP:	Network Time Protocol. The NTP is a protocol used to synchronize the clocks in millions of servers, workstations and PCs of the public internet and private networks.



<b>TERM</b>	<b>DESCRIPTION</b>
OCG:	Office Communication Gateway
OCE:	Office Configuration Editor – A program used to create configuration package files (Pac files) for iVIU PTC GEO, iVIU, VIU, GEO, CPU III, and GCP equipment.
Out Of Service:	The process for taking one or more pieces of equipment out of service for repair and/or maintenance.
Pac File:	A configuration Package File that can either be created in the office using the OCE.
PCB:	Printed Circuit Board
Pick Up Delay:	An internal delay time between when an input receives the signal to pick up and when it actually responds.
PTC:	Positive Train Control. An automated control system for railways that ensures the safe operation of rail vehicles using data communication between various control entities that make up the system.
Reboot:	To cause the system to restart by removing power for a few seconds, then reapplying power.
RJ-45:	Industry standard Ethernet port
RIO:	Relay Input Output Module
RS232:	Industry standard serial port.
RS-485:	A higher speed version of RS-232 that supports longer distances and multiple devices.
RTU:	Remote Telemetry Unit
RX:	Receive
RXD:	Receive Data
Serial bus:	The communication path that carries messages between the CPU and I/O modules installed in the GCP chassis. The serial bus is a set of solder runs on the motherboard (backplane) of the chassis.
Signal aspect:	The appearance of a fixed signal conveying an indication as viewed from the direction of an approaching train; the appearance of a cab signal conveying an indication as viewed by an observer in the cab.
SIN:	Site (Subnode) Identification Number - A twelve-digit ATCS address representing the module as a subnode on the network.
SNMP:	Simple Network Management Protocol. SNMP is an Internet-standard protocol for managing devices on IP networks.
SNTP:	Simple Network Time Protocol. A simplified version of NTP where storage of state data is not required
SSH:	Secure Shell. SSH is a network protocol for secure data communication and remote command execution.
TCP/IP Network:	Transmission Control Protocol / Internet Protocol. The suite of communications protocols used to connect hosts on the Internet. TCP/IP uses several protocols, the two main ones being TCP and IP. TCP/IP is built into the UNIX operating system and is used by the Internet, making it the de facto standard for transmitting data over networks.

<b>TERM</b>	<b>DESCRIPTION</b>
Track circuit:	Defined by AREMA as “An electrical circuit of which the rails of a track form a part.” A track circuit’s limits are established by the use of insulated rail joints.
TRK:	Track – The GCP module used to transmit and receive coded track patterns for railroad track circuits.
True RMS AC+DC:	A scale on a multimeter that measures the effective combined AC and DC portions of the total voltage. Used to measure the pulsed output of a crossing controller. Measured as VRMS.
TSR:	Temporary Speed Restriction
TX:	Transmit
TXD:	Transmit Data
UAX:	Acronym for Upstream Adjacent Crossing (Xing). UAX inputs are used to receive prediction information from an upstream GCP as inputs to a downstream GCP when insulated joints are in the approach circuit.
UCN:	Unique Check Number – A number used to detect file corruption.
UDP:	User Datagram Protocol - A transport protocol used primarily for the transmission of network management information. Not as reliable as TCP.
ULCP:	Universal Local Control Panel – Same as LCP.
USB Port:	Universal Serial Bus Port
USB Drive:	Types of memory devices that plug into a USB port. These devices are commonly called flash drives or memory sticks.
UTC:	Coordinated Universal Time.
VHF Communicator:	Communications device used for remote operations and calibration as well as data communications.
VIU:	Vital Interface Unit. A device that monitors switch positions and signal aspects and then generates vital status messages reflecting the current state of the monitored equipment.
VLAN:	Virtual Local Area Network
VLO:	Vital Lamp Output – A software-driven vital hardware output which drives a lamp on a Colorlight Signal to display a commanded aspect and verifies the lamp is operational (not shorted or out).
VLP:	Vital Logic Processor -- The processor mounted on the CPU module that is responsible for vital processing.
VPI:	Vital Parallel Input – A vital input to a module, designed primarily to read the state of a vital signaling relay.
VRMS:	Volt Root Mean Square – See True RMS AC + DC above.
VTP:	Virtual Local Area Network (VLAN) Trunk Protocol. A Cisco proprietary Layer 2 messaging protocol that manages the addition, deletion, and renaming of VLANs on a network-wide basis. VTP reduces administration in a switched network. When you configure a new VLAN on one VTP server, the VLAN is distributed through all switches in the domain. This reduces the need to configure the same

<b>TERM</b>	<b>DESCRIPTION</b>
	VLAN everywhere.
WAMS:	Wayside Alarm Management System – An office based application that communicates with and receives data from specially equipped crossings.
WCC/FPD:	Wayside Cluster Controller/Field Protocol Device. The WCC/FPD is often referred to as the Packet Switch. This equipment manages clusters of base stations and other communications links to the field. The WCC/FPD is installed in the office.
WCCMaint:	Software that runs on a PC used to configure and manage a network of WCC/FPD equipment. WCCMaint is often used to manage other communications equipment as well such as WCPs and BCPs.
WIU:	Wayside Interface Unit. Term used to refer to the VIU in PTC applications.
WSM:	Wayside Status Messages. Messages in EMP format reflecting the status of vital functions at a wayside location. These vital functions include signal aspects and switch positions.

This Page Intentionally Left Blank

## SECTION 1 - INTRODUCTION

### 1.0 INTRODUCTION

The purpose of this manual is to describe and detail the features and operations of the A80903 CPU III Module. The CPU III module can be used on the following systems:

- GCP 5000
- GCP 4000
- GCP 4000 for Electrified Territory (GCE)
- SGCP4000/MS4000

The scope of this manual is to cover the installation, use, functions, and features of the CPU III Module and how to interface the module with existing systems. Details on configuration procedures, configuration parameters, and system functions are not covered in this manual; rather this manual is to be used as a supplemental document to interface the CPU III Module functions and features relative to the information in the following GCP Manuals:

- GCP 5000 Application Guidelines (SIG-00-13-04)
- GCP 5000 Field Manual (SIG-00-13-03)
- GCP 4000 Application Guidelines (SIG-00-08-06)
- GCP 4000 Field Manual (SIG-00-08-10)
- GCP 4000 Plus Field Manual (SIG-00-12-68)
- SGCP 4000-MS4000 Installation & Instruction Manual (SIG-00-11-02)
- GCP 4000 GCE Installation & Instruction Manual (SIG-00-10-05)

The A80903 CPU III Module is also used in Geographic Signaling System - GEO<sup>®</sup> products.

## 1.1 GENERAL DESCRIPTION



**Figure 1-1 A80903 CPU III Module**

The A80903 CPU III Module is the next generation Central Processing Unit used in the Grade Crossing Predictor (GCP) equipment.

In systems where a Display module is not used:

- The CPU III eliminates the need to use the Diagnostic Terminal software by providing an Ethernet port and an internal Web User Interface (Web UI) for user Configuration, Diagnostics, Software upgrades, System status, and generating Reports and Logs.
- The CPU III has an output RS-232 port for configuration of the modules installed in the system using a DB-9 to DB-9 serial cable.

When the Display module is used, it should be used to perform the above functions. Most of the sections of this manual relating to menus cover the menus the user sees when no display is connected, only a subset of these menus is available when a Display is connected, see section 4.0 for information on how to use the CPU III when a Display is present.

The CPUIII can be used as a drop in replacement in existing SGCP4000/MS4000, GCP4000 and GCP5000 systems that use the CPU2+ (A80403-001/005) module.

The CPUIII will communicate with the Older Windows CE Display (A80407) and new Display module (A80485) via the serial port on the back plane using a standard DB-9 (Male) to DB-9 (Female) serial cable.

## 1.2 ORDERING INFORMATION

The CPU III may be ordered with or without Echelon® communications.

The following is the ordering information for the A80903 CPU III Module.

# 8000-80903-2021

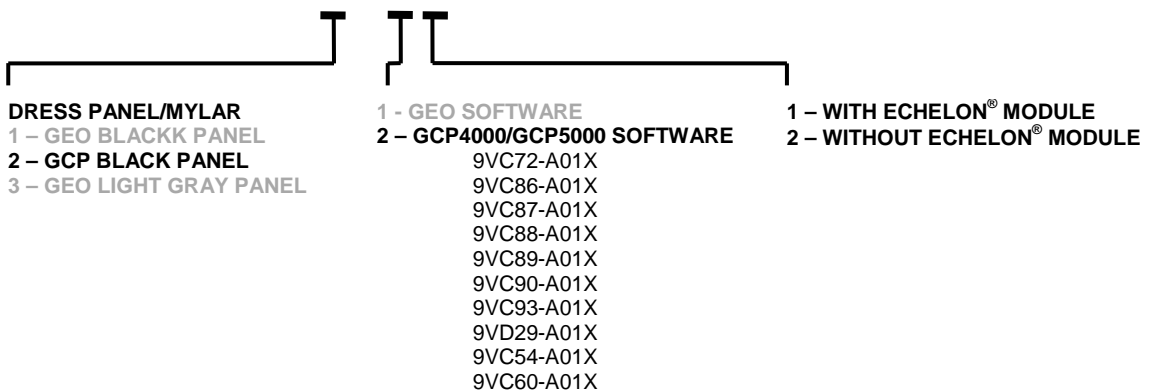

### NOTE

### NOTE

The CPU III may be ordered with or without Echelon® communications, however the Echelon® LAN is required for communication to SEAR Ili, ordering the Echelon® Module option is recommended.

This Page Intentionally Left Blank



## SECTION 2 – CPU III MODULE OPERATION

### 2.0 CPU III MODULE OPERATION

#### 2.1 INDICATORS, CONTROLS, AND CONNECTORS

**Table 2-1 CPU III Indicators, Controls, and Connectors**

Item	Name	Function
Displays	4-character display	Used with the SEL and NAV push buttons to provide a maintainer interface.
Controls	2-Push Button Select/Navigate	Select (SEL) button steps through each menu The Navigate (NAV) button steps through each sub menu of the selected menu.
Indicators	16 LEDs (red)	See Table <b>Table 2-2</b>
Connectors	RS-232 (DTE) Serial Port (DB-9)	RS-232 (DTE) used to interface the CPU III Communication Processor externally to other modules in the GCP chassis for the purpose of programming the modules
	LAPTOP Ethernet (RJ-45)	RJ-45 Ethernet port used to interface the CPU Vital Communication Processor with a laptop / personal computer. Provides access to external communication configuration files via the Web User Interface (Web UI)

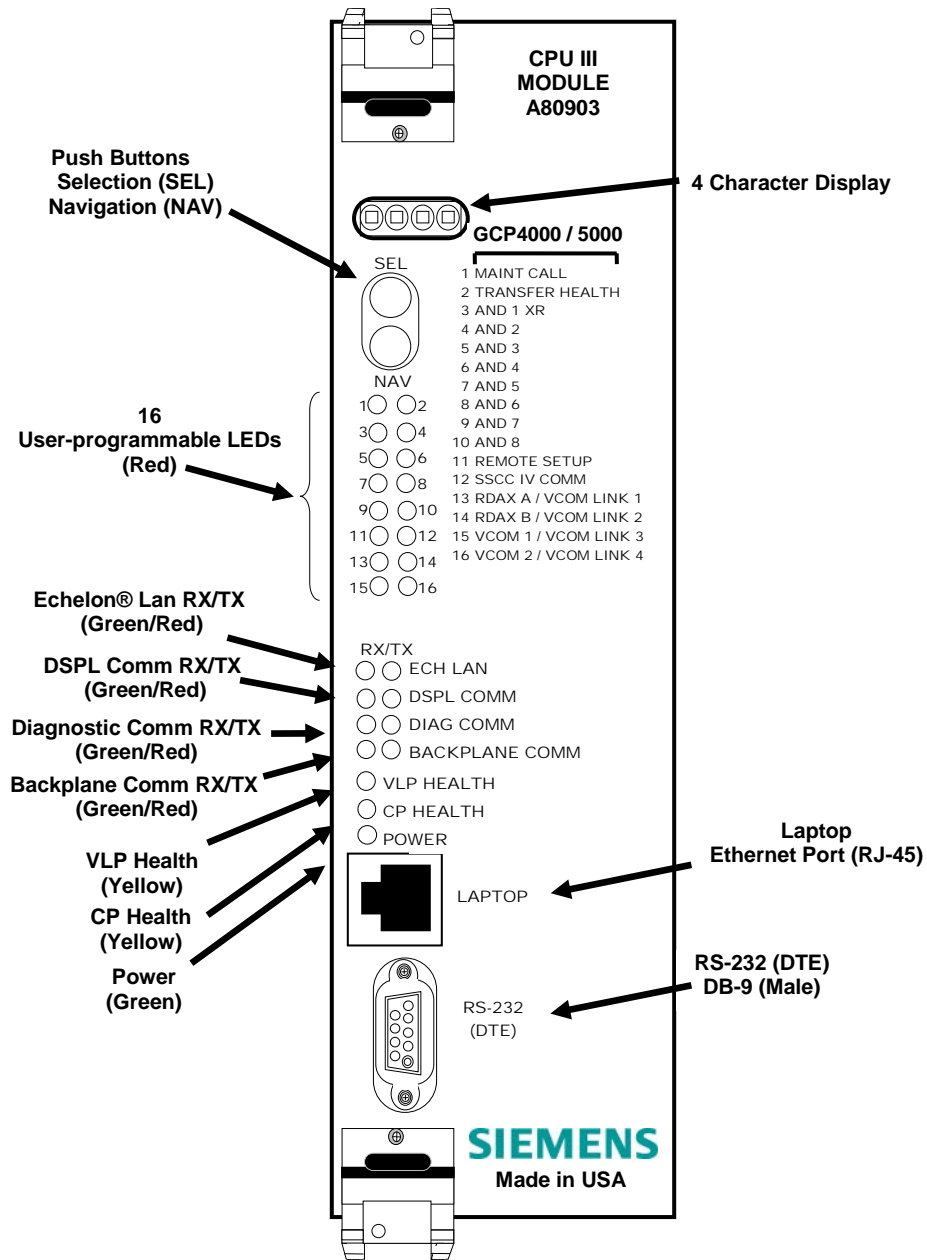

Figure 2-1 CPU III Indicators, Controls, and Connectors

## **2.1.1 CPU III Local User Interface**

The CPU III Local User Interface consists of a 4 Digit Display and two push buttons, Select (SEL) and Navigate (NAV) buttons enable the user to see the mcf and mef name and view the CPU III IP address on GCP4000 and GCP5000 units. On the SGCP4000/MS4000 units the user can use the Select (SEL) and Navigate (NAV) buttons for setup and configuration.

### **2.1.1.1 Using the Select and Navigate Push Buttons**

The Select and Navigate push buttons are used in the following manner. The Select (SEL) button is pushed to go to the next main menu. The Navigate (NAV) button is pushed to step through the sub menus. The Select (SEL) button will select the displayed parameter when the parameter is being modified. It also will select the displayed parameter allowing the Navigate (NAV) button to navigate sub-menu items of the displayed parameter. To back up to the previous sub menu, double click the Navigate (NAV) button. Continue to double click the NAV button to step back to the previous sub menu until the main menu is reached. The 4 Digit Display will show the current menu selected. Long titles will scroll across the display.

### 2.1.1.2 CPU III Local User for GCP

The following Tables describe the LED Indicators and Display Messages.

**Table 2-2 LED Indications**

LED		Function	Description
NAME	Color		
<b>1 Maint Call</b>	Red	Maintenance Call	On – maintenance call output on (system healthy, Maintenance Lamp Call is off) Off - maintenance call output off (system unhealthy, Maintenance Lamp Call is on)
<b>2 Transfer Health</b>	Red	Transfer Health	On – transfer signal is being generated Off – transfer signal is being not being generated. In a redundant system if transfer card is on AUTO it will be counting down
<b>3 (AND 1 XR)</b>	Red	AND 1 XR	On – AND 1 XR is energized Off – AND 1 XR is Deenergized
<b>4 thru 10 AND 2 to AND 8</b>	Red	AND 2 through AND 8	On – AND 2-8 is Energized Off – AND 2-8 is Deenergized or Not Used
<b>11 Remote Setup</b>	Red	Remote Setup Session	
<b>12 SSCC IV Comm</b>	Red	Vital Comms Status for indicated link	SSCC IV in vital session with CPU III
<b>13: RDAX A/ VCOM LINK1</b>	Red	Vital Comms Status for indicated link	Radio Dax Link A (GCP4000) or VComms Link 1 (GCP5000) in session with another GCP system
<b>14: RDAX B/ VCOM LINK2</b>	Red	Vital Comms Status for indicated link	Radio Dax Link B (GCP4000) or VComms Link 2 (GCP5000) in session with another GCP system
<b>15: VCOM 1/ VCOM LINK3</b>	Red	Vital Comms Status for indicated link	VComms Link 1 (GCP4000) or VComms Link 3 (GCP5000) in session with another GCP system
<b>16: VCOM2/ VCOM LINK4</b>	Red	Vital Comms Status for indicated link	VComms Link 2 (GCP4000) or VComms Link 4 (GCP5000) in session with another GCP system
<b>ECH LAN RX</b>	Grn	Echelon Message Received	Flashes when the CPU is receiving an ATCS message via the Echelon LAN.
<b>ECH LAN TX</b>	Red	Echelon Message Sent	Flashes when the CPU is transmitting an ATCS message via the Echelon LAN.
<b>DSPL COMM RX</b>	Grn	Display Port Message Received	Flashes when the CPU is receiving data from the display module.
<b>DSPL COMM TX</b>	Red	Display Port Message Sent	Flashes when the CPU is sending data to the display module.
<b>DIAG COMM (CP) RX</b>	Grn	Diag Port Message Received	Flashes when the CPU is receiving data from the communications processor diagnostic ( <b>DIAG CP</b> ) serial port.
<b>DIAG COMM (CP) TX</b>	Red	Diag Port Message Sent	Flashes when the CPU is transmitting data on the communications processor diagnostic ( <b>DIAG CP</b> ) serial port.
<b>BACK-PLANE COMM RX</b>	Grn	Backplane Message Received	Flashes when the VLP is receiving data from the serial bus.
<b>BACK-PLANE COMM TX</b>	Red	Backplane Message Sent	Flashes when the VLP is sending data onto the serial bus.
<b>VLP HEALTH</b>	Yel	VLP Health Status	Flashes slowly (1Hz) when the CPU VLP is functioning normally. Flashes fast (4Hz) when the VLP is unhealthy
<b>CP HEALTH</b>	Yel	CP Health Status	Flashes slowly (1Hz) when the CP is functioning normally.
<b>POWER</b>	Grn	Power Indication	On steadily when power is applied to the module.

**Table 2-3 CPU III GCP Display Messages**

<b>Display</b>	<b>Mode</b>	<b>Meaning</b>	<b>System State</b>
<b>MCF Name; e.g. GCP-T6X-02-1</b>	Scrolling	VLP is healthy	CPU is healthy.
<b>BOOT</b>	Steady	CPU is booting up.	CPU is booting up. Crossing is activated.
<b>CRC*</b>	Steady	MCF CRC is incorrect for the current MCF	Entered CRC does not match CRC of MCF. Crossing is activated.
<b>MCF*</b>	Steady	CPU is not healthy because the MCF is not valid.	Reboot CPU or reload MCF. Crossing is activated.
<b>SIN*</b>	Steady	Site Identification Number is invalid.	Enter valid SIN. Crossing is activated.
<b>VLP UCFG</b>	Scrolling	VLP is unconfigured.	No comm to I/O modules. Crossing is activated.
<b>VLP INITIAL</b>	Scrolling	The CP is transferring the configuration from NVRAM to the VLP.	No comm to I/O modules. Crossing is activated.
<b>BURNING MCF</b>	Scrolling	The CP is copying the MCF from the ECD into flash memory.	No comm to I/O modules. Crossing is activated.
<b>NO VLP COMMS</b>	Scrolling	The CP is not communicating with the VLP. VLP could be rebooting or performing its initial configuration checks	No comm to I/O modules. Crossing is activated.
<b>ERASING THE ECD</b>	Scrolling	Erasing its flash memory in preparation for copying the MCF from the ECD into flash memory.	No comm to I/O modules. Crossing is activated.
<b>ADR*</b>	Steady	The radio DAXing neighbor ATCS address is invalid	Address of DAX session cannot be computed. Enter valid SIN
<b>INI*</b>	Steady	Rebooting	System Reboot - Crossing is activated.
<b>Exxx</b>	Steady	Internal error, System will reboot. xxx is 3 digit hex number	Reload MCF - Crossing is activated.
<b>LMCF</b>	Steady	Rebooting	System Reboot - Crossing is activated.
<b>ICLK</b>	Steady	Rebooting	System Reboot - Crossing is activated.

**NOTE****NOTE**

Steady messages may alternate with other messages

The CPU has two processors: the Communications Processor (CP) and the Vital Logic Processor (VLP). When new software is installed into the CP, the VLP continues running without interruption until the CP setup is complete. When the CP software has been downloaded it will reboot the CP, this will also cause the VLP to reboot.

This means that if the Model 5000/4000 GCP system is healthy and the crossing is not active, the VLP continues to correctly control the crossing while the new software installation into the CP is in progress. If the Display Module is being used, uploading an mef into the CPU III using the Ethernet port will render the crossing inoperable as the CPU III will be in the unconfigured state. The crossing will be restored once the CPU III configuration is reestablished.

## SECTION 3 – CPU III WEB USER INTERFACE (WEB UI)

### 3.0 CPU III WEB USER INTERFACE (WEB UI)

**NOTE****NOTE**

The screen displays in this section are examples. Actual screens will vary depending on the application, configuration, software, and equipment installed.

The CPU III Web UI provides status and programming features found in the Diagnostic Terminal program and the GCP DT Display. The following screen displays of the Web UI are provided as a guide to navigating Web UI and the features available. Detailed programming parameters and procedures are found in the following manuals:

- GCP 5000 Application Guidelines (SIG-00-13-04)
- GCP 5000 Field Manual (SIG-00-13-03)
- GCP 4000 Application Guidelines (SIG-00-08-06)
- GCP 4000 Field Manual (SIG-00-08-10)
- GCP 4000 Plus Field Manual (SIG-00-12-68)
- SGCP 4000-MS 4000 Installation & Instruction Manual (SIG-00-11-02)
- GCP 4000 GCE Installation & Instruction Manual (SIG-00-10-05)

### 3.1 CPU III WEB UI SCREEN DISPLAYS FOR GCP

The CPU III has a Web Interface which enables the user to configure the GCP locally as well as remotely through the Laptop/Ethernet Port (RJ-45) on the front of the CPU III Module. The CPU III Laptop Port default protocol is set as DHCP Server. Using a web browser enter the assigned IP address for the GCP. Default address from the factory is <https://192.168.255.081>. Note the Web UI uses the HTTP Secure (https) protocol unless the user has configured the protocol as non-secure (http). The CPU III DHCP Server protocol will assign the laptop an IP address and connect the user to the GCP.

If the equipment is to be connected to a network it will be necessary for the user to initially connect to the Web UI using a laptop and configuring the Ethernet port as a Client, failure to do so will cause an interruption of the network since two DHCP servers will be introduced onto the network. In the client mode, the network will assign an IP address to the CPU III. To find the assigned IP Address press the CPU III NAV push button until the display shows the laptop IP address (IP xx.xxx.xxx.xxx). Enter the IP address shown on the display on your Web Browser to connect to the CPU III. When connecting to a network, a notice that the connection is not secure may appear as shown in Figure 3-1. Click on the “Advanced” button and a new screen will pop up, click on the “Add Exception” button to bring up another screen, click on the “Confirm Security Exception” which will allow the connection to continue. Checking the “Permanently Store This Exception” box will remember this setting.

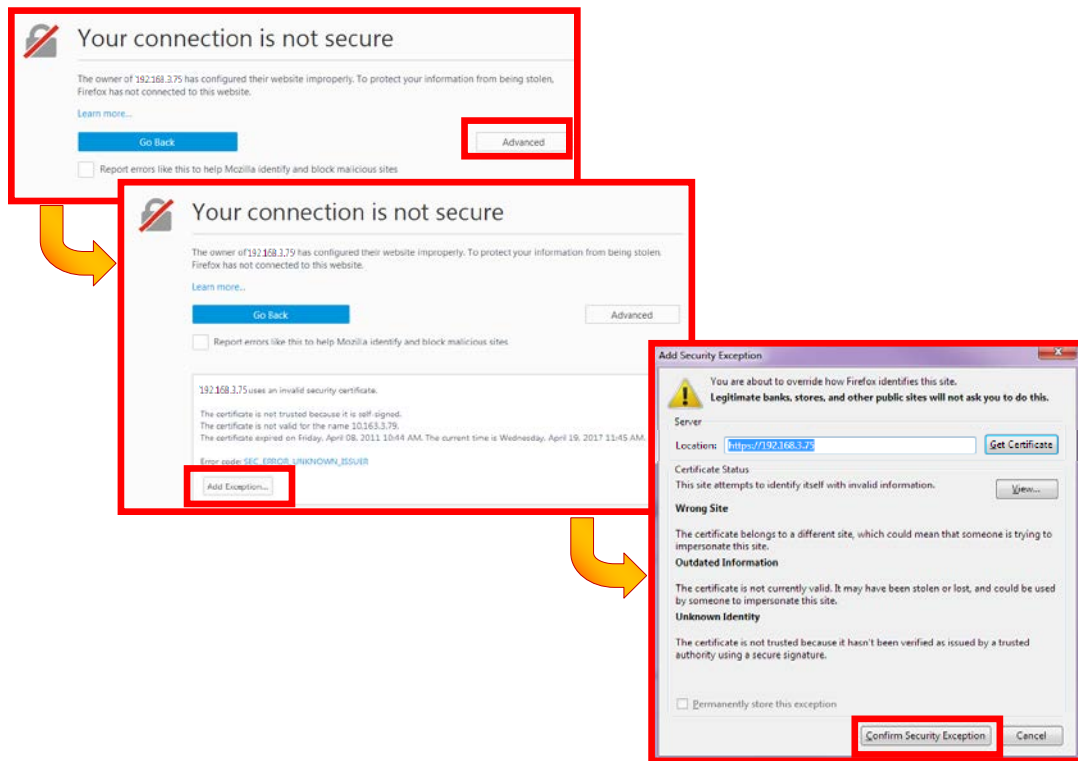

Figure 3-1 Unsecure Connection Warning

Enter the assigned password. Default password from the factory is available by calling Railroad Field Support at: 1-800-793-7233.

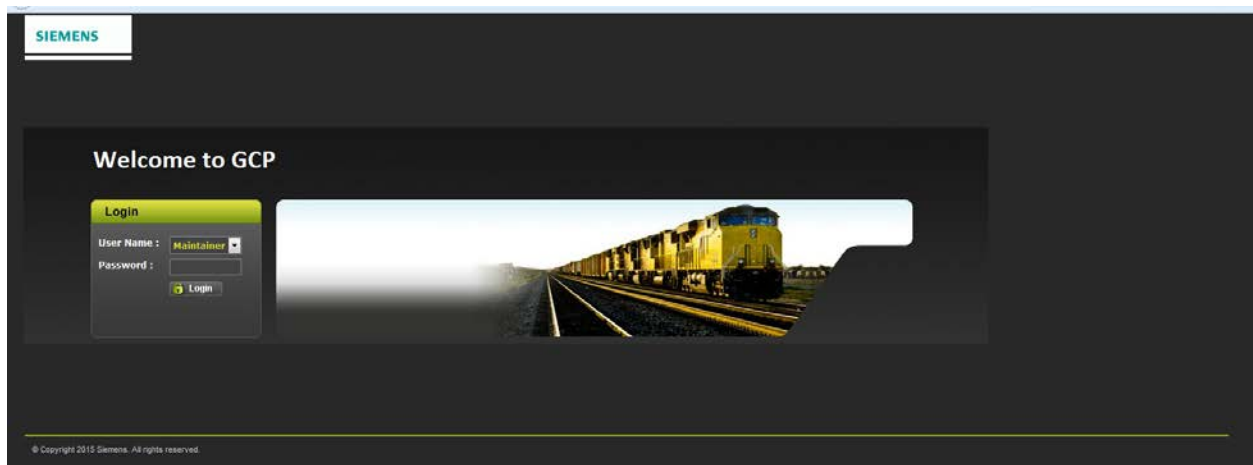

Figure 3-2 CPU III Web UI - Log In Screen



The Web UI will open with the System View screen provided there are no Diagnostic messages present in the system. In the event there are Diagnostic messages are present, the Diagnostic page will appear instead of the System View. (See Section 3.1.8 for Diagnostic Screen details).

The figure shows two possible opening screens for the CPU III Web UI. The left screenshot displays the 'System View' screen, which includes a table of track data:

Trk	EZ	EX	MPH	Status
1	100	100	0	Up
2	100	104	0	Up

The right screenshot displays the 'Diagnostics' screen, which includes a table of diagnostic messages:

Select	Description	Code
TR 1	No Communications	2017
TR 2	No Communications	2017
SSCC3 1	No Communications	2017
SSCC3 2	No Communications	2017
VLP2	WCF CRC Incorrect	3004
VLP2	V.P. Invalid@pred	3010

A red arrow with the word 'OR' points from the System View screen to the Diagnostics screen, indicating that the system will display either screen depending on the presence of diagnostic messages.

Figure 3-3 CPU III Web UI - Opening Screen – System Views or Diagnostics

### 3.1.1 CPU III Web UI System View

The System View provides an overview of the GCP. System View has two sub menus Track/PSO and SSCC, each of their own sub menus to refine the detail for the user. The following figures display a typical GCP. Actual data on the display will vary depending on the type of GCP equipment and configuration.

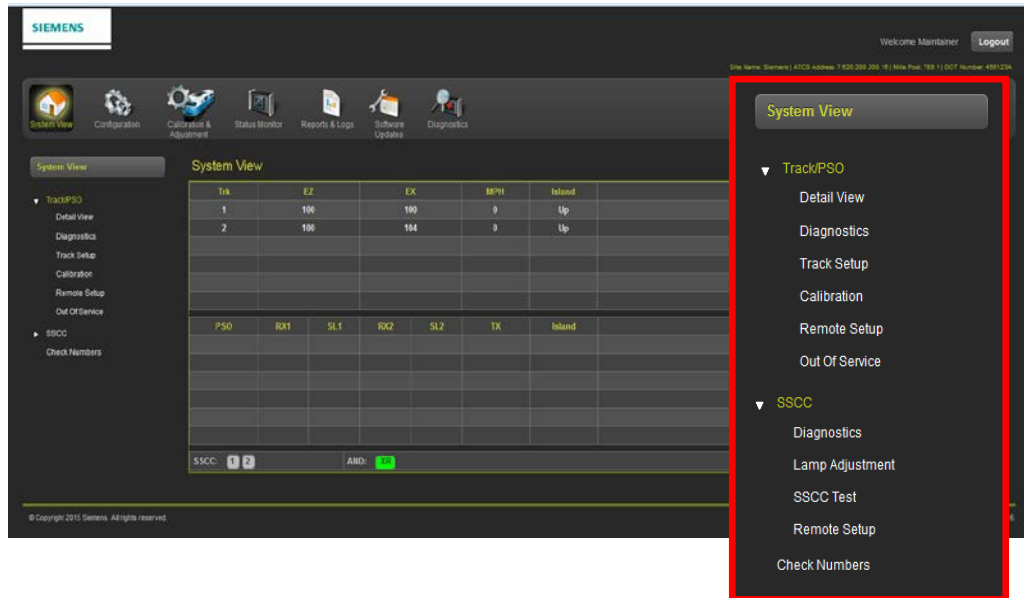

Figure 3-4 CPU III Web UI – System View Menus

Right clicking on a module line will bring up the sub-menus (same as Track/PSO menu on the left column) for the selected module.

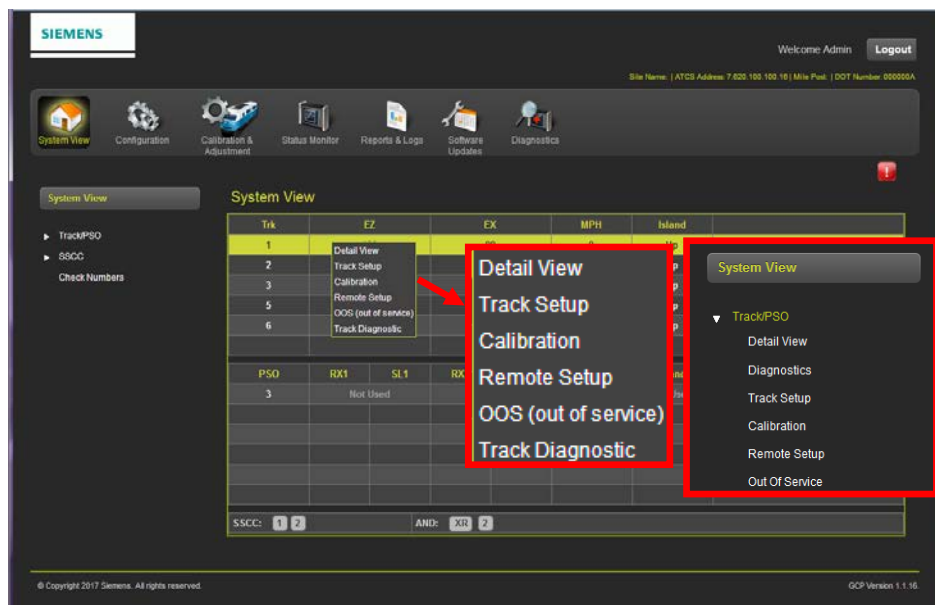

Figure 3-5 CPU III Web UI – System View Module Sub-menus

### 3.1.1.1 CPU III Web UI - System Views – Track/PSO Menu

The Track/PSO Detail View has two tabs, in this example, and displays the track status and configuration data. The LED indicators indicate green for energized state, white for deenergized and show an hour glass symbol when running a pickup delay.

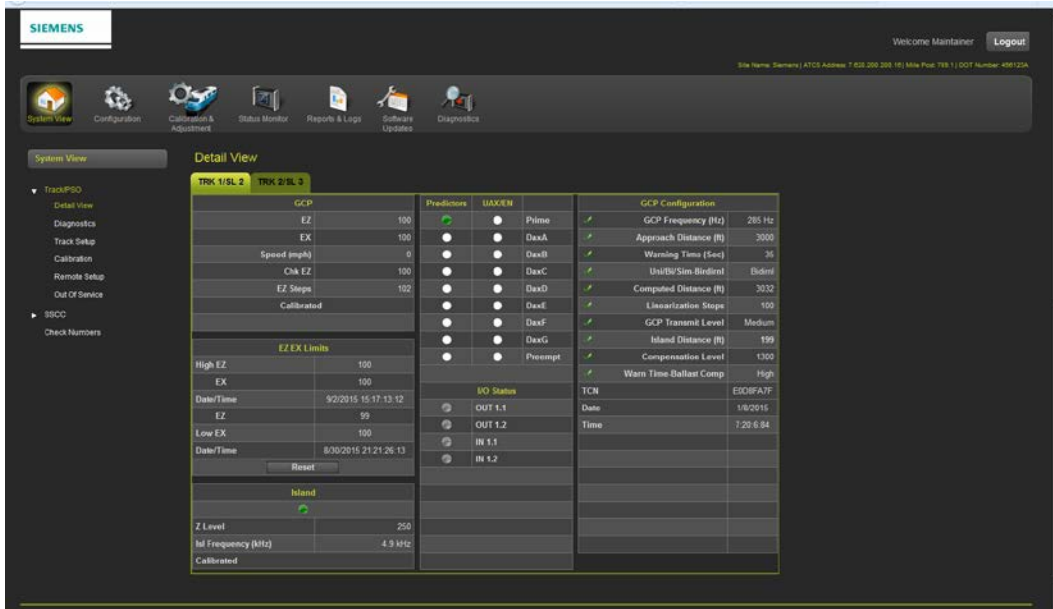

Figure 3-6 CPU III Web UI – System View – Track/PSO Detail View

### Diagnostic Screen

The Diagnostic screen details problem areas and their locations. An attention icon will display in the upper right corner in the event of a Diagnostic message being present. This icon will appear on all Web UI screens to alert the user to go to the Diagnostics Menu.

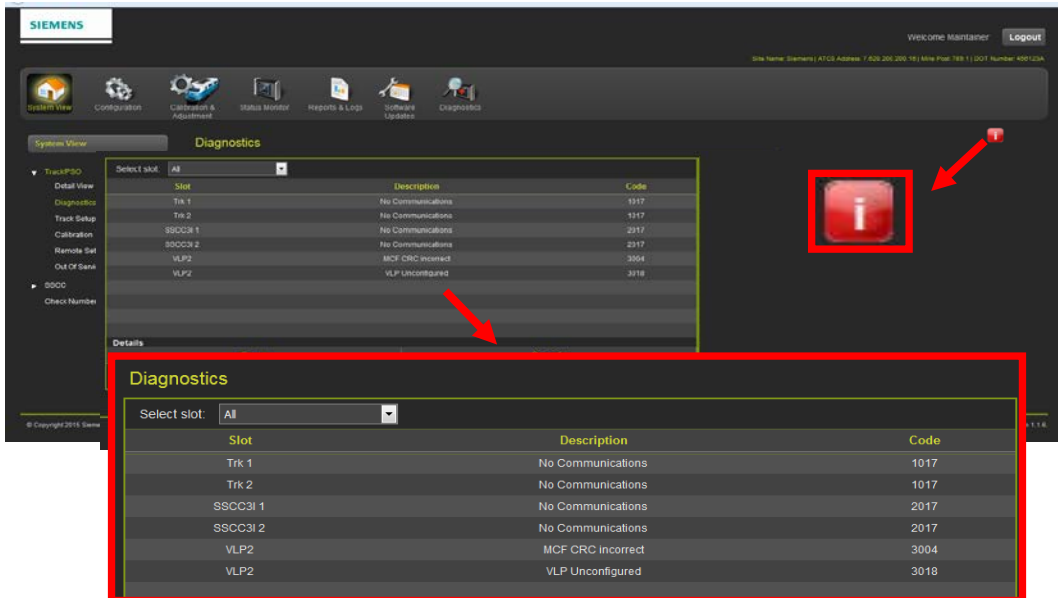







Figure 3-7 CPU III Web UI – System View – Track/PSO Diagnostics

The Track/PSO Diagnostics as well as the Diagnostics Menu will display the following icons in the upper right corner of the screen to alert the user of Diagnostic information available. A list of the icons is shown in Figure 3-8.

### DIAGNOSTIC ICONS

-  **Diagnostics Alert Icon**
-  **No VLP Communications Link**
-  **Creating MCF Database**
-  **Processing AUX Files**
-  **Creating Real Time Database**

**Figure 3-8 CPU III Web UI – System View – Track/PSO Diagnostics - Icons**

### Track Setup

The Track Setup screen provides a simple screen where the commonly adjusted configuration parameters for the track card can be set. Setting parameters requires the system to be Unlocked (See the System Unlock Procedure Section 3.1.9).

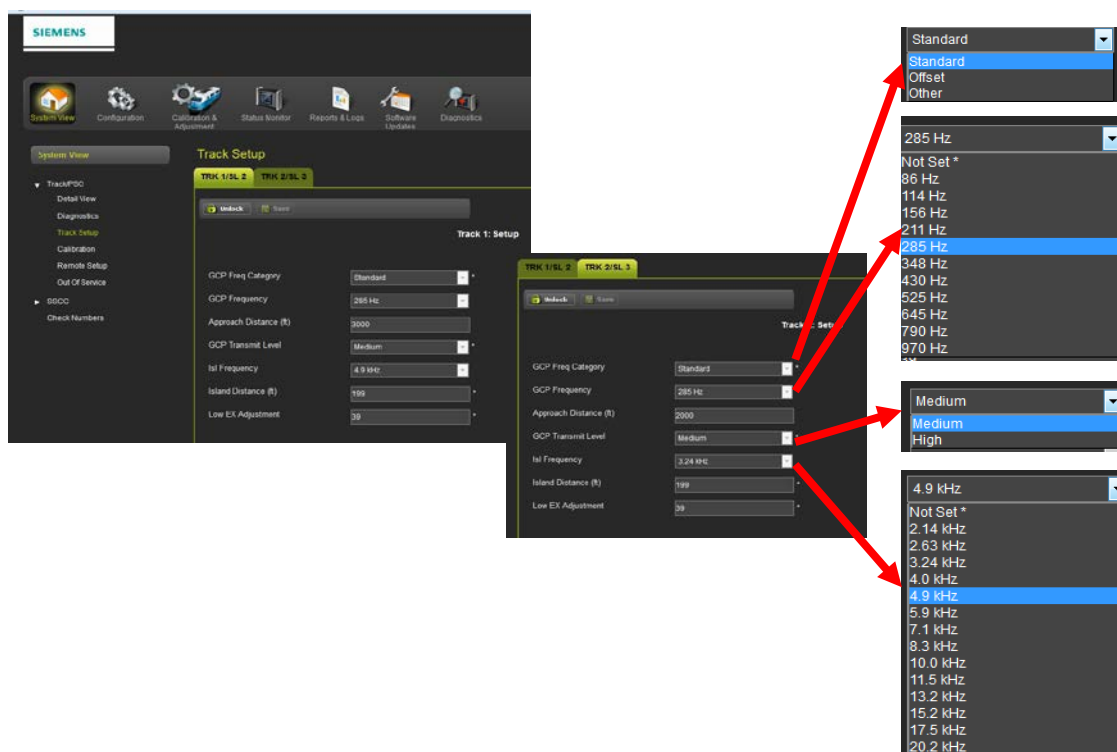

**Figure 3-9 CPU III Web UI – System View – Track/PSO Track Setup**

## Track/PSO Calibration

The Track/PSO Calibration screen is used to calibrate the GCP, Island, and perform approach and linearization. The screen also allows the user to manually set the computed approach and linearization steps, or bypass these setup steps when they are not necessary (for example if the GCP has been recalibrated due to a ballast change, the computed approach and linearization can be bypassed. See the GCP manual for instructions on track setup.)

A tab will appear for each configured Track/PSO (in this example two tabs are available).

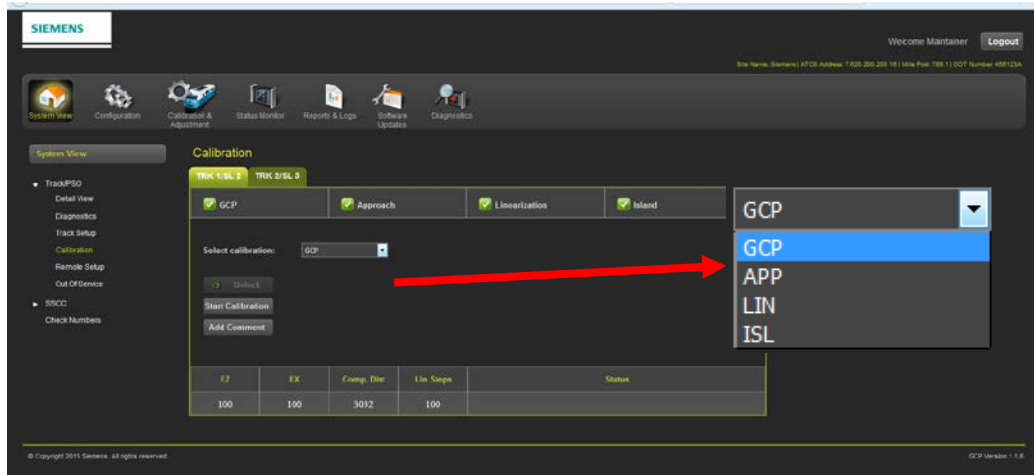

Figure 3-10 CPU III Web UI – System View – Track/PSO Calibration

## Remote Setup

### NOTE

### NOTE

This screen is used when the GCP system has a VHF communicator which enables the user to remotely set lamp voltages using their hand held VHF radio.

The GCP sends and receives commands via the VHF Communicator which includes a half-duplex radio. The radio cannot receive a reply until it is finished transmitting. DO NOT send back responses until the message is completed.

To enter a password or to select a value on the handheld VHF radio, press and hold the transmit button/key, and then enter the numeric key values required.

A password must be preceded by an asterisk and a number symbol (\*#) to be accepted as valid.

When an invalid password is received, the menu system is disabled for 30 seconds. When the menu system is reactivated (after 30 seconds), the correct password must be entered to continue.

After a valid password is entered, the system will respond with the DTMF tones for “##.”

Entering “##” at any time during remote operation returns the function to the initial Start position.



**WARNING**

**AFTER PERFORMING REMOTE GCP CALIBRATION USING THE VHF COMMUNICATOR, RETURN TO THE GCP AND VERIFY THAT EACH CALIBRATION IS PROPERLY IMPLEMENTED. REVIEW THE MAINTENANCE LOG OR THE CPU STATUS LOG AS PART OF THE VERIFICATION PROCESS.**

Prior to beginning remote calibration, the DOT Crossing Number must be entered. For further details refer to the GCP Field manual.

Details on the SSCC Remote Setup are available in the GCP4000 Field Manual, Document Number: SIG-00-08-10.

The SSCC Remote Setup screen enables the user to obtain the password for remote access of the SSCC. To access the information the system must be unlocked [1], a confirmation pop-up will appear [2] press OK an on-site person will push the Select (SEL) button to acknowledge the request. The unlock button will dim and the Get and Cancel buttons illuminate, press the 'GET' [3] button, another confirmation pop-up will appear, press the OK [4] button, a request will go out to the CPU III module and an on-site person will push the Select (SEL) button to acknowledge the request. Another screen will come up with the password and timeout information [5]. Select the appropriate check box [6] to indicate which operation is to be performed (e.g. if the intent is to calibrate Track 1, select the Track 1 Remote setup check box). When using the hand held radio, key in the Remote password supplied on this screen.

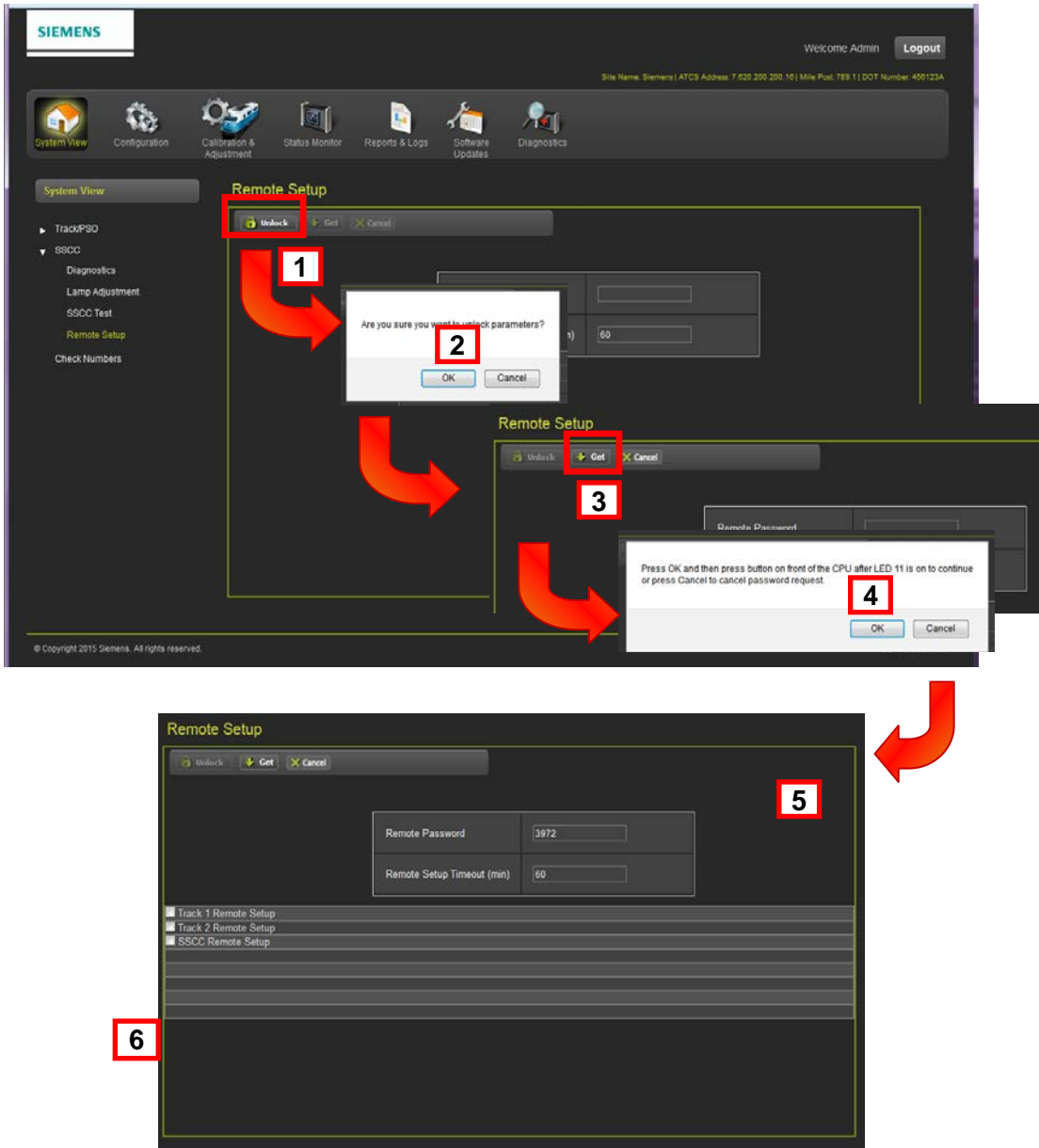
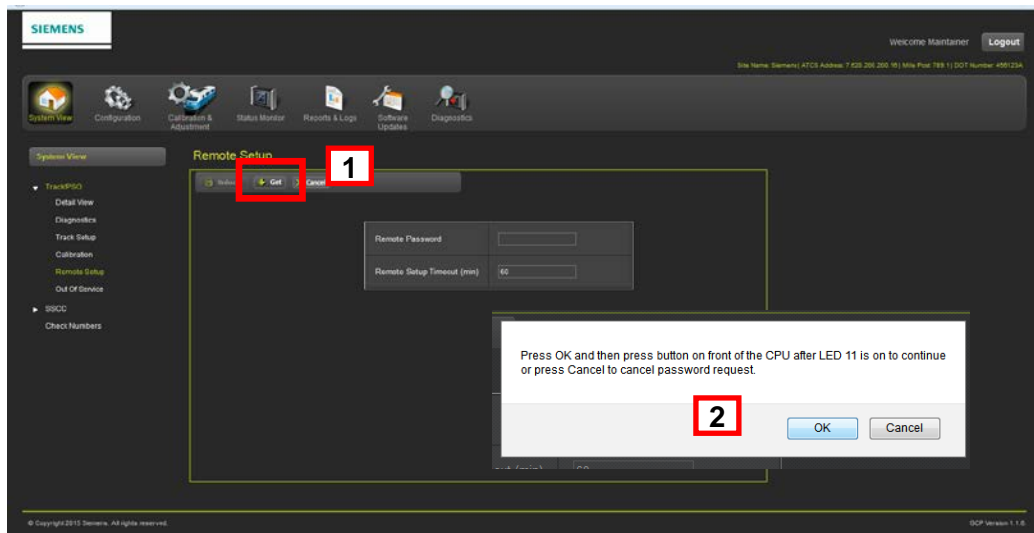

Figure 3-11 CPU III Web UI – System View – SSCC Remote Setup

The Remote Setup screen requires the unlocking of the System (See the System Unlock Procedure Section 3.1.9). Press the “Get” button [1] and the pop-up window will come up advising confirmation from the on-site person, click the OK button [2] to continue.



**Figure 3-12 CPU III Web UI – System View – Track/PSO - Remote Setup Request**

The following screen will coming up with the Remote Setup information [3]. Select the appropriate check box [4] to indicate which operation is to be performed (e.g. if the intent is to calibrate Track 1, select the Track 1 Remote setup check box). When using the hand held radio, key in the Remote password supplied on this screen.

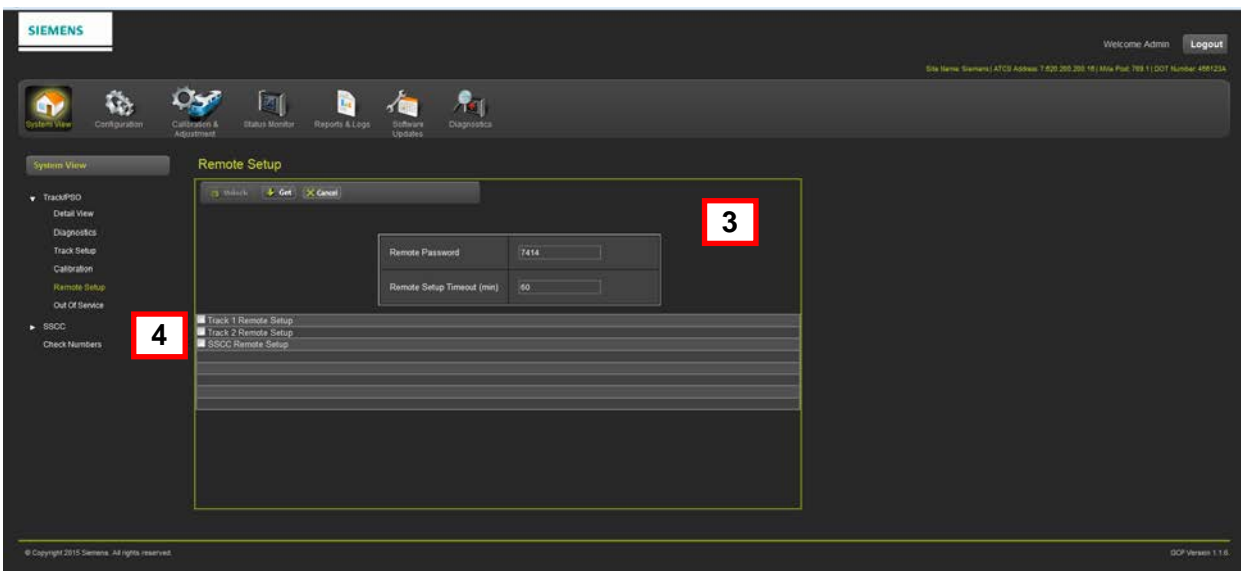

**Figure 3-13 CPU III Web UI – System View – Track/PSO - Remote Setup Information**



**Out of Service (OOS)****⚠ WARNING****WARNING**

OBSERVE ALL RAILROAD AND/OR AGENCY SAFETY PROCEDURES TO ENSURE THE SAFETY OF TRAINS, VEHICLES, AND PEDESTRIANS BEFORE PLACING ANY GCP, TRACK, OR ISLAND OUT OF SERVICE.

**⚠ WARNING****WARNING**

RAILROADS OR AGENCIES ARE RESPONSIBLE FOR ENSURING ONLY PROPERLY TRAINED AND AUTHORIZED PERSONNEL HAVE ACCESS TO THE GCP EQUIPMENT. WARNING DEVICES MAY NOT OPERATE AS INTENDED WHILE PERFORMING THESE PROCEDURES. TAKE ALTERNATE MEANS TO WARN VEHICULAR TRAFFIC, PEDESTRIANS, AND EMPLOYEES.

ENSURE ALL TRACKS PLACED OUT OF SERVICE HAVE BEEN PUT BACK INTO SERVICE.

BEFORE PLACING THE TRACK BACK IN SERVICE PERFORM THE FOLLOWING:

- VERIFY TRACKS ARE FREE OF ANY AND ALL TRACK RELATED ISSUES.
- VERIFY THE PROPER COMPONENTS ARE USED, WIRED, AND PROGRAMMED AS SPECIFIED BY THE RAILROAD'S OR AGENCY'S APPROVED WIRING/INSTALLATION DIAGRAMS AND PROCEDURES.
- VERIFY COMPLETE SYSTEM OPERATION AS SPECIFIED BY THE RAILROAD'S OR AGENCY'S TEST PROCEDURES.

FAILURE TO FOLLOW THESE GUIDELINES MAY LEAD TO INCORRECT OR UNSAFE OPERATION OF THE TRACK CIRCUIT.

The Out of Service screen enables the user to take a GCP, Track, or Island Out of Service (OOS). An OOS timeout can be initiated with a timeout timer adjustment as shown in the figure below. If a track module uses both the grade crossing prediction and island, the island cannot be taken out of service by itself; the GCP portion must be taken out as well. If the GCP is configured to use DT and OOS inputs, the appropriate OOS input controlling this track must be energized before using the Web UI to take the GCP or Island out of service.

**NOTE****NOTE**

One common out of service timer is used for all tracks, set the value before taking any track out of service. Once a track is out of service, the timer will start. Taking a second track out of service will not restart the timer, it will keep running with its originally configured value

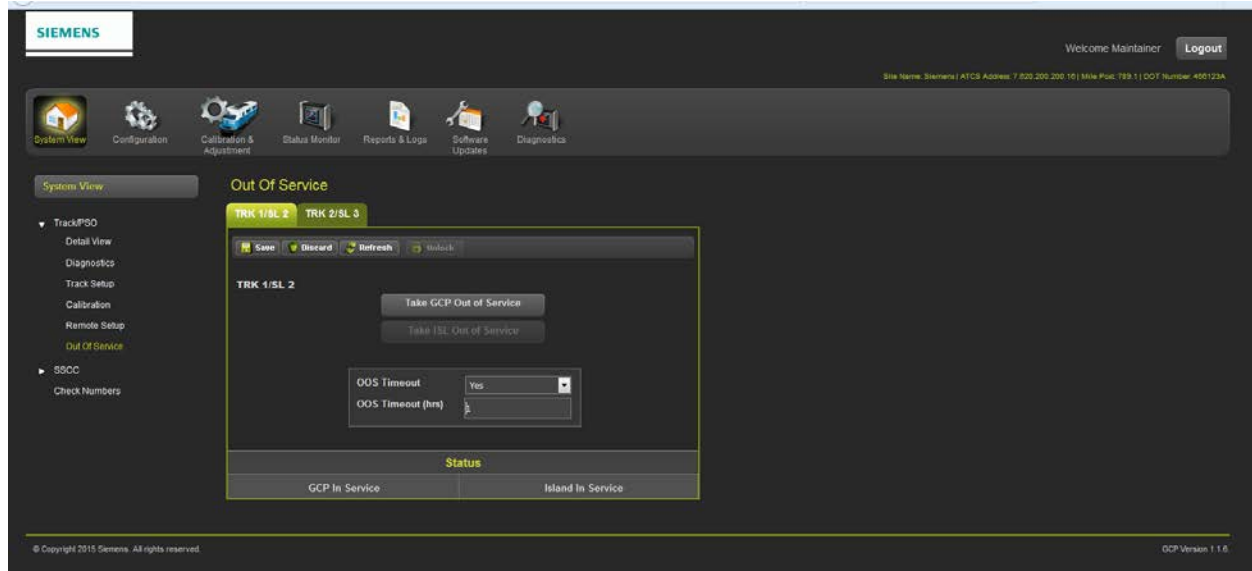

Figure 3-14 CPU III Web UI – System View – Track/PSO – Out Of Service Screen

### 3.1.1.2 CPU III Web UI - System Views – SSCC Menu

The first SSCC sub-menu is the Diagnostics Screen. The user can select individual SSCC components or view all at the same time using the drop-menu. The Diagnostic screen details problem areas and their locations. An attention icon will display in the upper right corner in the event of a Diagnostic message being present. This icon will appear on all Web UI screens to alert the user to go to the Diagnostics Menu.

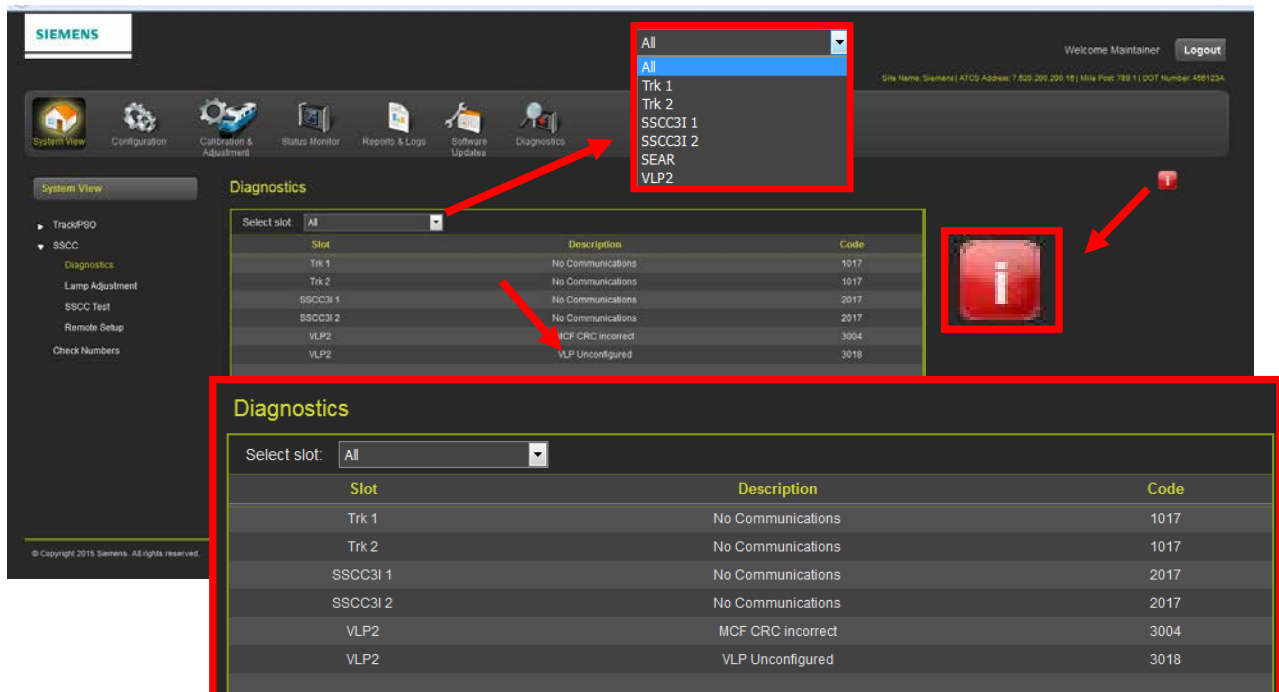
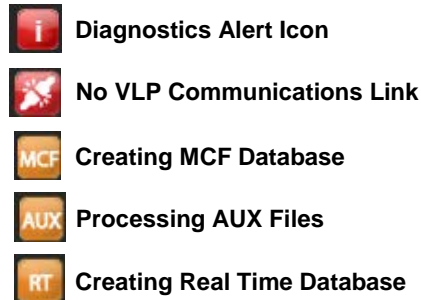

Figure 3-15 CPU III Web UI – System View – SSCC Diagnostics

The SSCC Diagnostics as well as the Diagnostics Menu will display the following icons in the upper right corner of the screen to alert the user of Diagnostic information available. These icons will display on all Web UI screens. A list of the icons is shown in

### DIAGNOSTIC ICONS



**Figure 3-16 CPU III Web UI – System View – SSCC Diagnostics - Icons**

### SSCC Lamp Adjustment

The SSCC Lamp Adjustment screen provides for SSCC lamp voltage adjustments. The screen has two tabs, one for each SSCC which will bring up the adjustment parameters for the selected SSCC. The lamp voltages can only be adjusted when the crossing is not active. If the crossing is not active, selecting edit will turn on the indicated lamp. Enter the new voltage and check the RMS voltage at the lamp according to the procedure described in (GCP Field Manual).

#### NOTE

#### NOTE

If a lamp is turned on and the crossing activates the activation will override the test command and the lamp will flash as normal.  
If the lamp is turned on and the user moves away from this screen the lamp will be turned off

To adjust the lamps on the second SSCC3i, select the tab SSCC 2/SL9

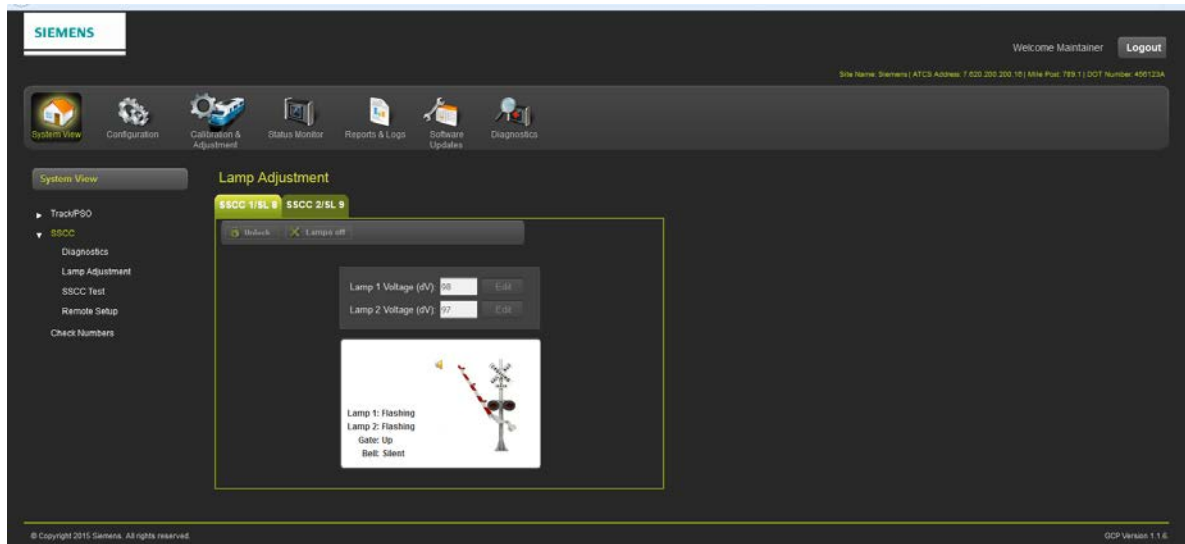

**Figure 3-17 CPU III Web UI – System View – SSCC Lamp Adjustment**

## SSCC Test



**WARNING**  
THE SSCC TEST MODE WILL NOT PREEMPT TRAFFIC SIGNALS. VERIFY THAT VEHICLES ARE CLEAR OF THE WARNING DEVICES BEFORE ACTIVATING THE SIGNALS.



**NOTE**  
While in Test Mode, if a train approaches (XR input logic de-energizes), the test is cancelled and the crossing activates normally. When the train departs, the system remains in normal operation.

The SSCC Test screen provides the user with seven tests for each of the SSCC units as shown in the figure below.

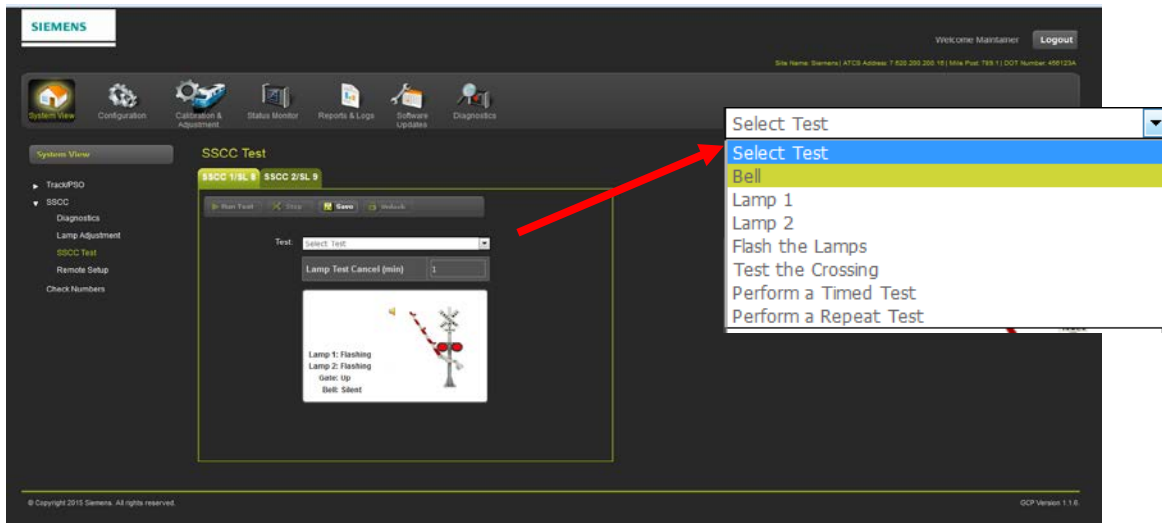

Figure 3-18 CPU III Web UI – System View – SSCC Test

The figure below displays the test screens for each of the SSCC test options.

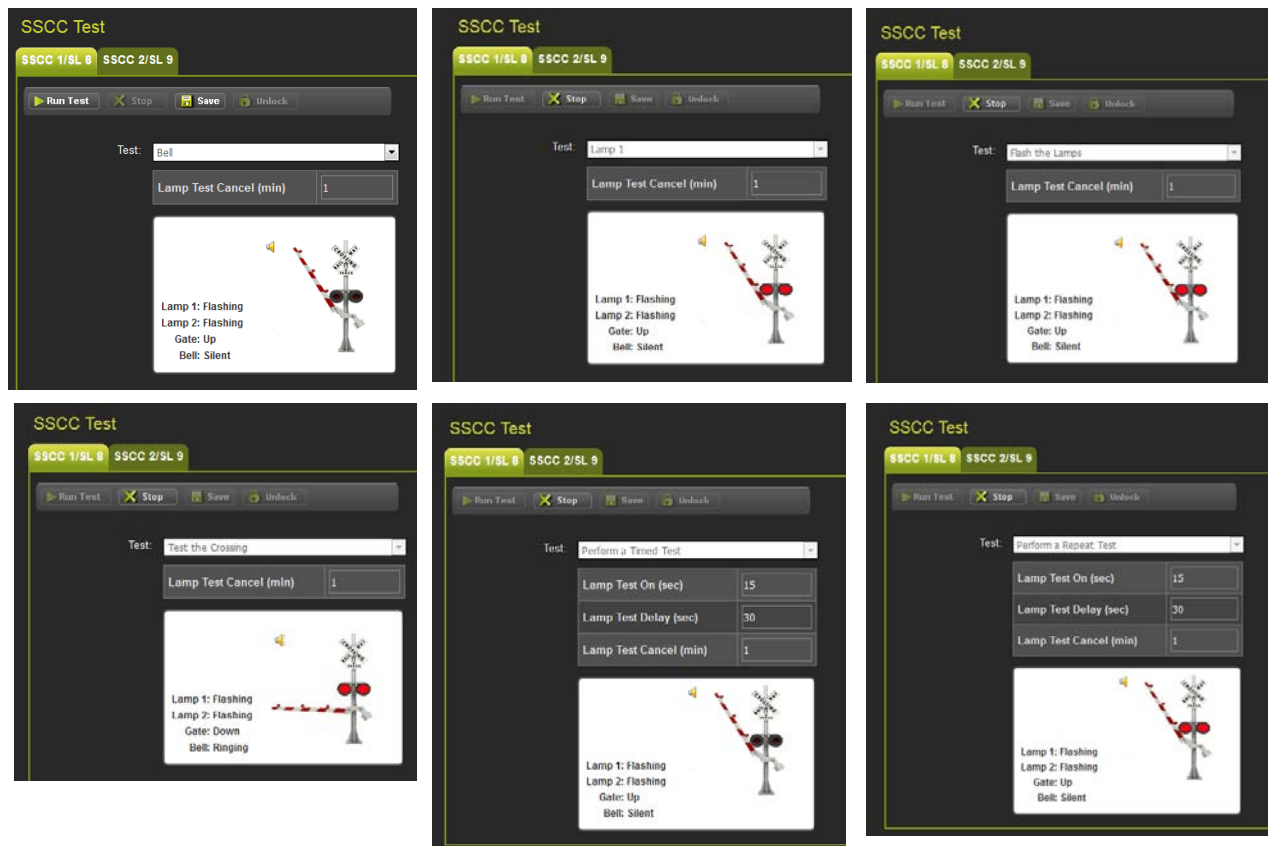

Figure 3-19 CPU III Web UI – System View – SSCC Test Options

### SSCC TEST ITEMS

The following SSCC tests may be performed:

- **Bell:** Turn on the bell output
- **Lamp 1:** Turn on Lamp 1 output
- **Lamp 2:** Turn on Lamp 2 output
- **Flash the Lamps:** Test the lamp outputs on both controllers
- **Test the crossing:** Flash the lights, ring the bell, run the gate delay, and then drop the gate.

After these tests have been started, they remain active until:

- The **Stop** button is selected,
- The Lamp Test cancel time expires
- The window is closed

### Types of Timed Tests

**Timed Tests:** When the Timed Test is started, the GCP performs the following sequence:

- Pauses for the programmed **Lamp Test Delay** time
- Flashes the lamps for the programmed **Lamp Test On** time
- Turns the lamps off
- Stops the test.

**Repeat Tests:** When the Repeat Test is started, the GCP performs the following sequence:

- Pauses for the programmed Lamp Test Delay time
- Flashes the lamps for the programmed Lamp Test On time
- Turns the lamps off for twice the programmed Lamp Test Delay time
- Flashes the lamps for the programmed Lamp Test On time
- Turns the lamps off
- Stops the test.

### Parameters for Timed Tests

Parameters for each SSCC timed test are set in the fields below the **Test:** field.

The **Lamp Test On** field designates the duration of the Lamp On test.

Select the **Edit** button to the right of the field to open the **Set Parameter** dialog box. This **Set Parameter** dialog box allows the test duration timer to be modified.

- Default value: **15 sec**
- Valid entry range: **15 to 60** seconds

The **Lamp Test Delay** field designates the time between test selection and test start. Select the **Edit** button to the right of the field to open the **Set Parameter** dialog box. This **Set Parameter** dialog box allows the **Lamp Test Delay** timer to be modified.

- Default value: **30 sec**
- Valid entry range: **30 to 120** seconds

The **Lamp Test Cancel** field designates the automatic test termination time following test initiation. Select the **Edit** button to the right of the field to open the **Set Parameter** dialog box. This **Set Parameter** dialog box allows the **Lamp Test Cancel** timer to be modified.

- Default value: **5 min**
- Valid entry range: **1 to 15** minutes

### Test Status Indications

The status of the SSCCIII module appears in the gate display field at the bottom of the window during tests.

Four status notations appear during operational tests:

- **Off** indicates that the SSCCIII module lamp drive outputs are off.
- **Ringing** indicates that the SSCCIII module bell output is energized.
- **Flashing** indicates that the SSCCIII module lamp outputs are alternately energizing (flashing).
- **Failed** indicates that a bell, lamp, or crossing gate output failure has been detected.

### SSCC Remote Setup

This menu brings up the remote session screen as discussed on Section 3, Page 3-6, Remote Setup.

### 3.1.1.3 CPU III Web UI - System Views – Check Numbers

The Check Numbers screen provides the user with information on the installed MCF file name and the associated CRC numbers as shown in the figure below. The example below is from a GCP5000, this screen will vary in content with other models and applications.

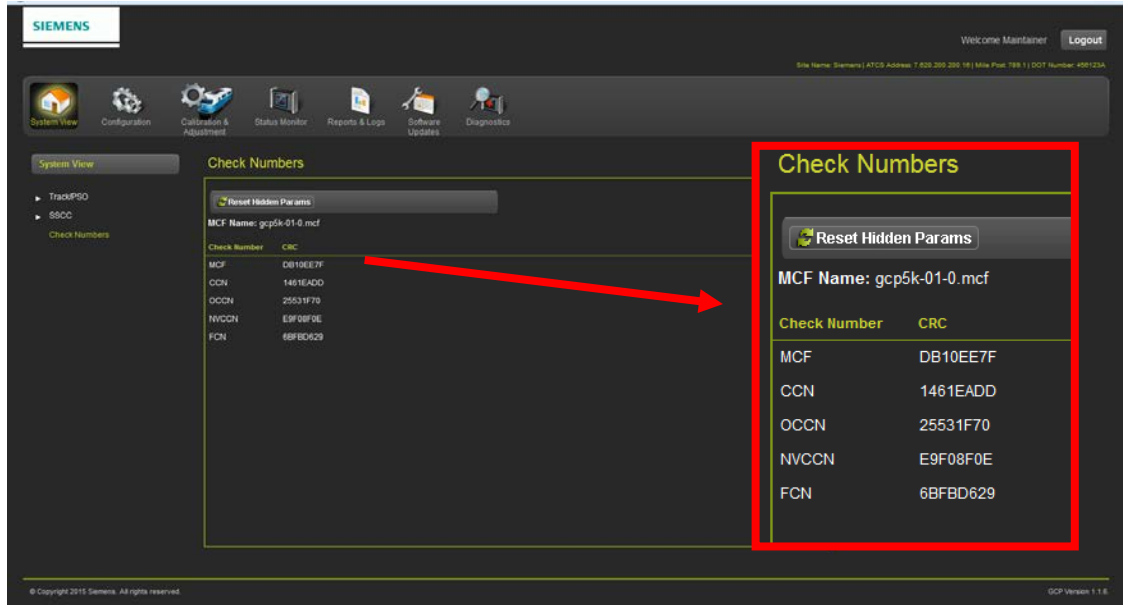

Figure 3-20 CPU III Web UI – System View – Check Numbers

#### NOTE

#### NOTE

In a GCP5000 system the check numbers are instantly available. In a GCP4000 system the CPU3 will re-calculate the current OCCN based upon the current configuration settings, so there will be a small delay in obtaining the number readouts.

#### NOTE

#### NOTE

When setting up a GCP system the user will program the parameters according to the site plans and compare the OCCN to that on the plans. Sometimes the OCCN can mismatch if hidden parameters which are included in the OCCN are not set at their default value. If the OCCN does not match the plans, select the 'reset hidden params' button, this will set all the hidden parameters back to their default values, which may then result in the OCCN matching.

### 3.1.2 CPU III Web UI – GCP5000 Configuration

The Configuration Menu provides for the configuration and programming of the GCP. The Setup Wizard steps through each of the programming and configuration elements. Separate Menus are available for programming and I/O assignments. The following figures will display the Configuration sub menus for the GCP5000. For the GCP 4000 see Section 3.1.3.

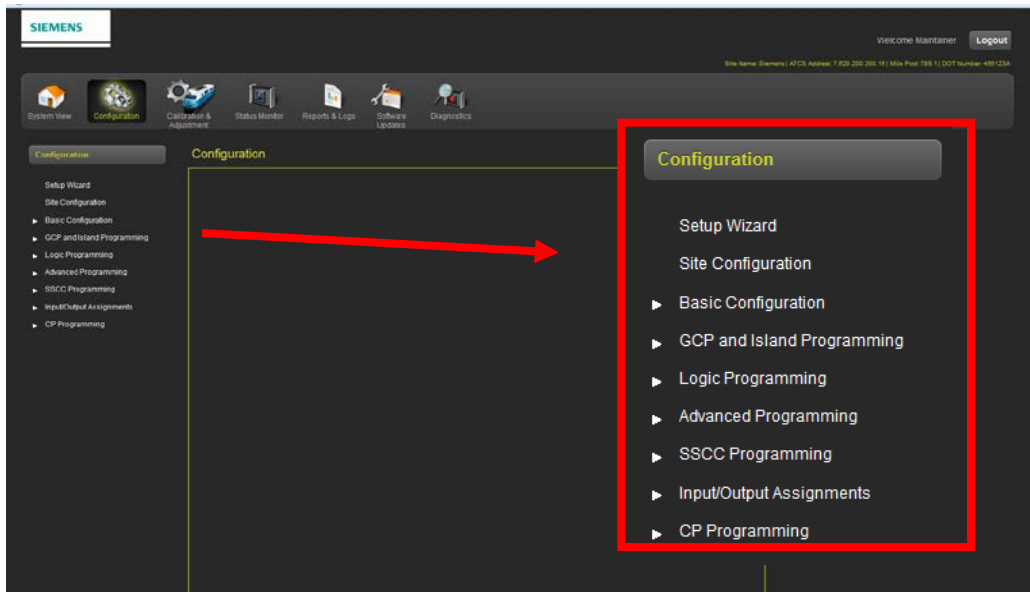

Figure 3-21 CPU III Web UI – Configuration Menu

#### 3.1.2.1 CPU III Web UI – GCP5000 Configuration – Setup Wizard

The GCP Setup Wizard has a list of templates that can be accessed individually and setup by the user as shown in the figure below.

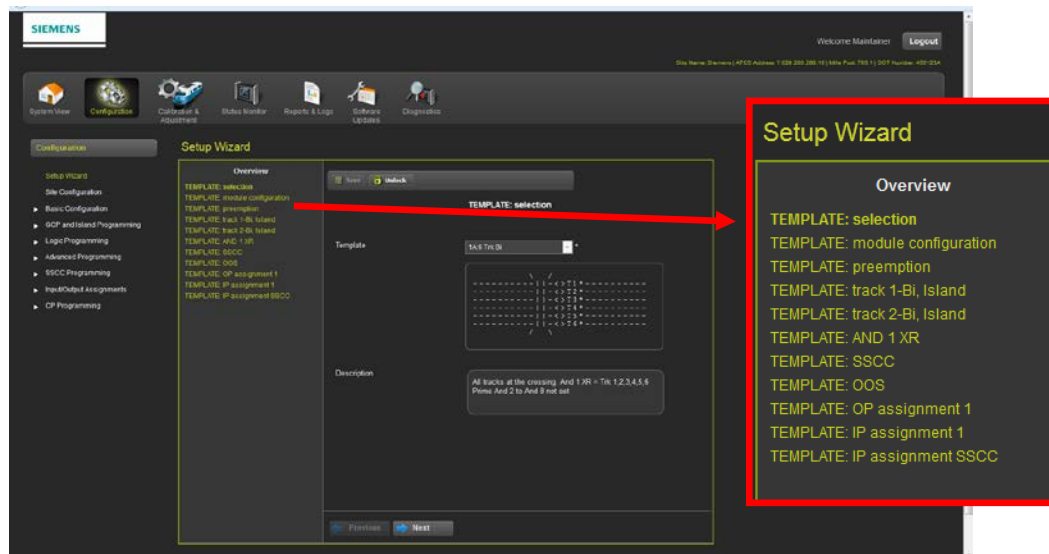

Figure 3-22 CPU III Web UI – GCP5000 Configuration – Setup Wizard



The Setup Wizard has a progression of screens as shown below for each setup template. When the last element is completed, clicking the NEXT button will revert back to the first screen. Parameters for each setup screen are found the GCP manuals.



Figure 3-23 CPU III Web UI – GCP5000 Configuration – Setup Wizard Screens

### 3.1.2.2 CPU III Web UI - GCP5000 Configuration – Site Configuration

The Site Configuration screen lists all of the Site information. The user can make necessary changes to the parameters. In most cases this information will not change from the original information programmed into the system. This menu is only visible for a GCP5000, for a GCP4000 see Section 3.1.3.

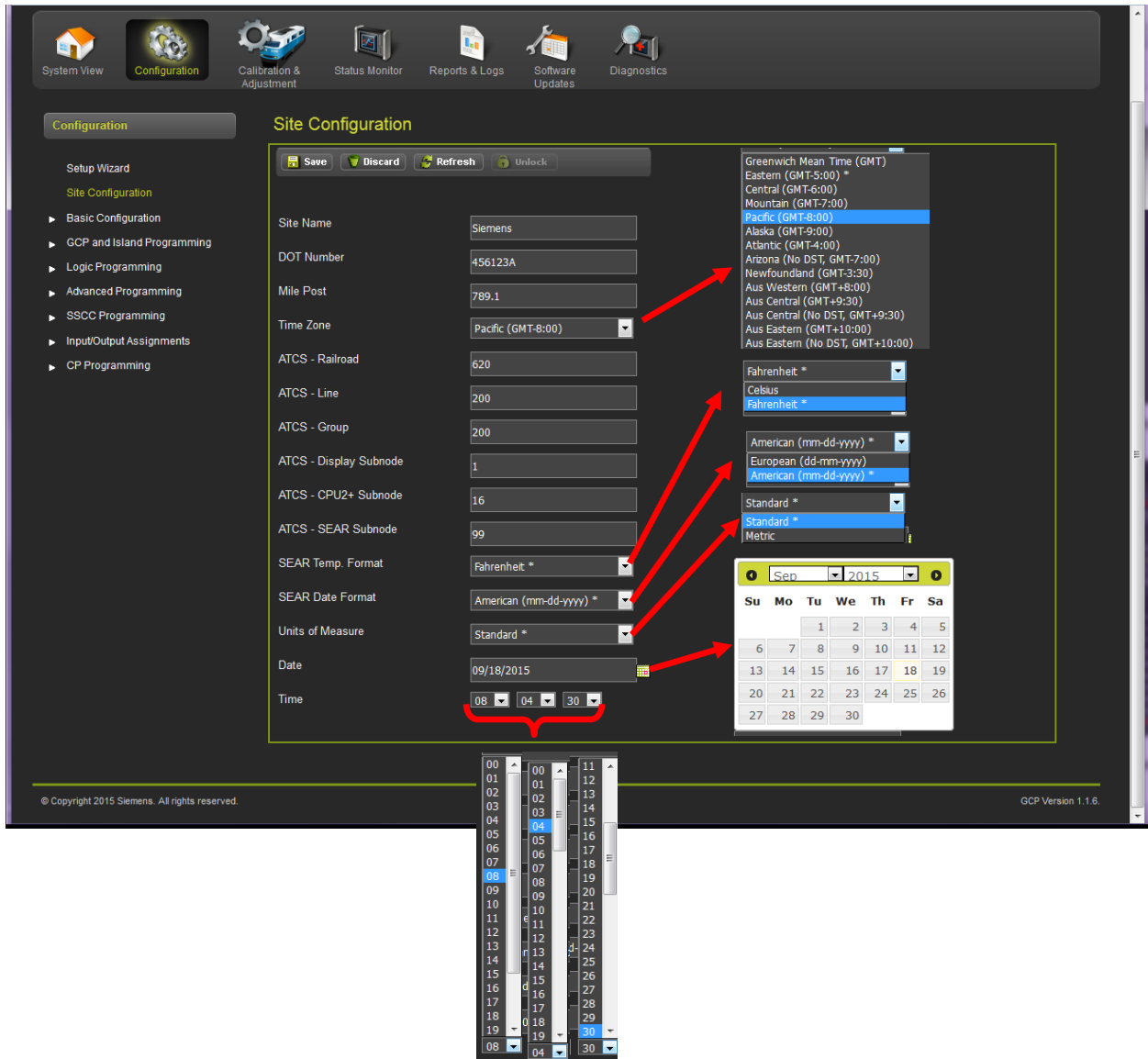

Figure 3-24 CPU III Web UI – GCP5000 Configuration – Site Configuration

### 3.1.2.3 CPU III Web UI – GCP5000 Configuration – Basic Configuration

The Basic Configuration Menu has seven sub-menus:

- Set Template
- Module Selection
- Preemption
- MS/Restart
- Vital Comms Links
- Out Of Service
- Set to Default

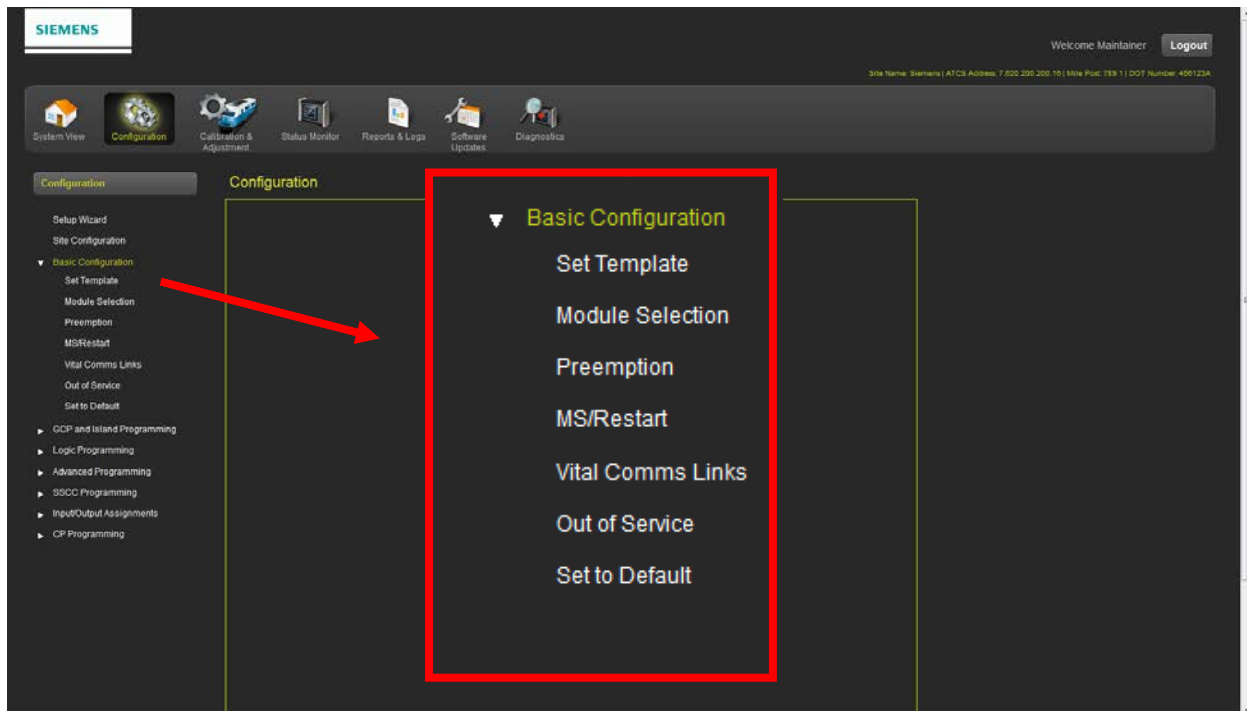

Figure 3-25 CPU III Web UI – GCP5000 Configuration – Basic Configuration

### 3.1.2.4 CPU III Web UI – GCP5000 Configuration – GCP and Island Programming

The GCP and Island Configuration menu has Track sub-menus. The number of sub-menus will depend on the number of tracks programmed into the system. In this example two tracks are programmed and two sub-menus Track 1 and Track 2 are shown. Each sub-menu has eight sub-menus with parameters that can be configured by the user. The figure below displays an example listing of the GCP and Island menu structure.

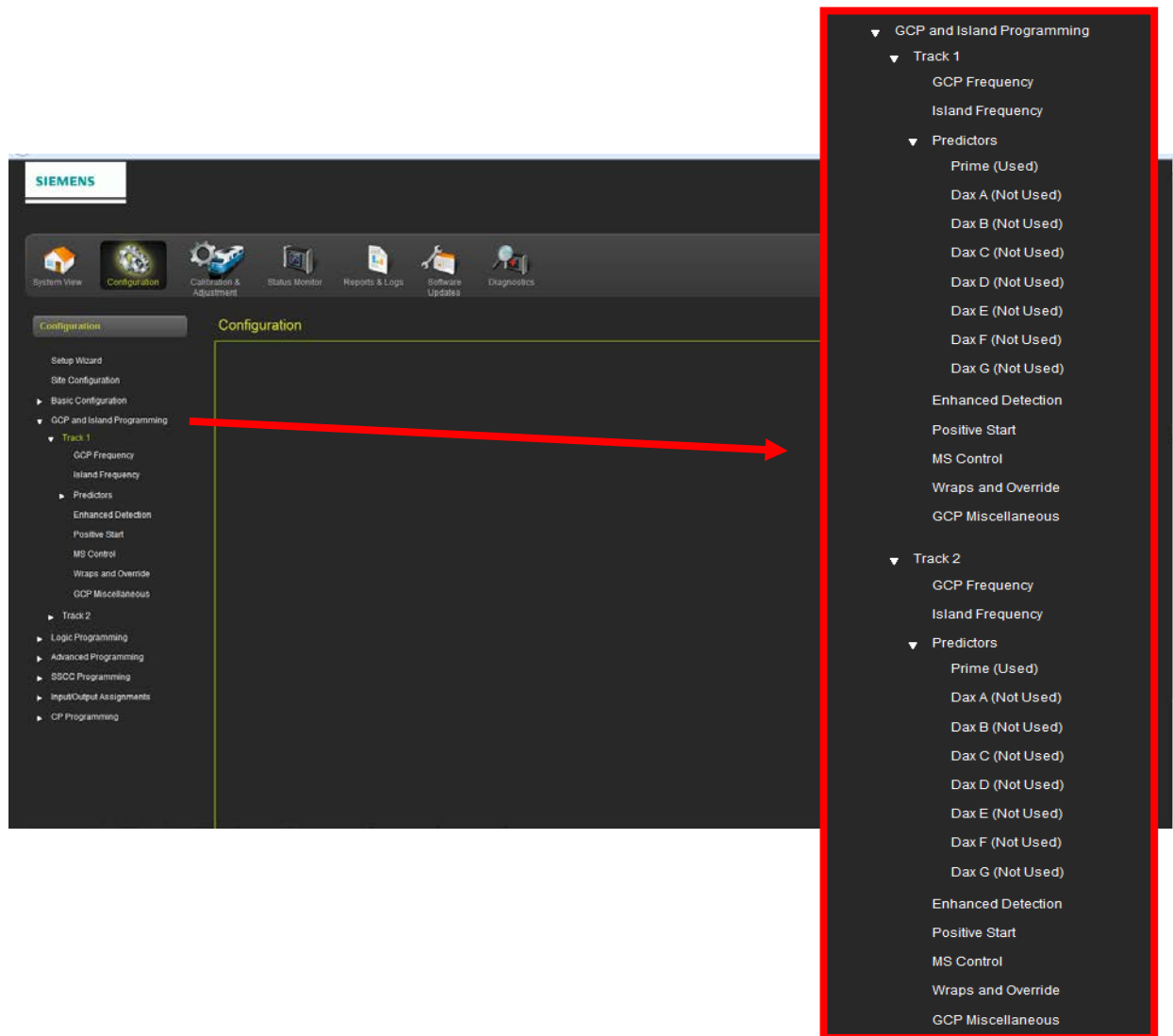

Figure 3-26 CPU III Web UI – GCP5000 Config – GCP and Island Programming Menu

### 3.1.2.5 CPU III Web UI – GCP5000 Configuration – Logic Programming

The Logic Programming menu has five sub-menus as shown in the figure below.

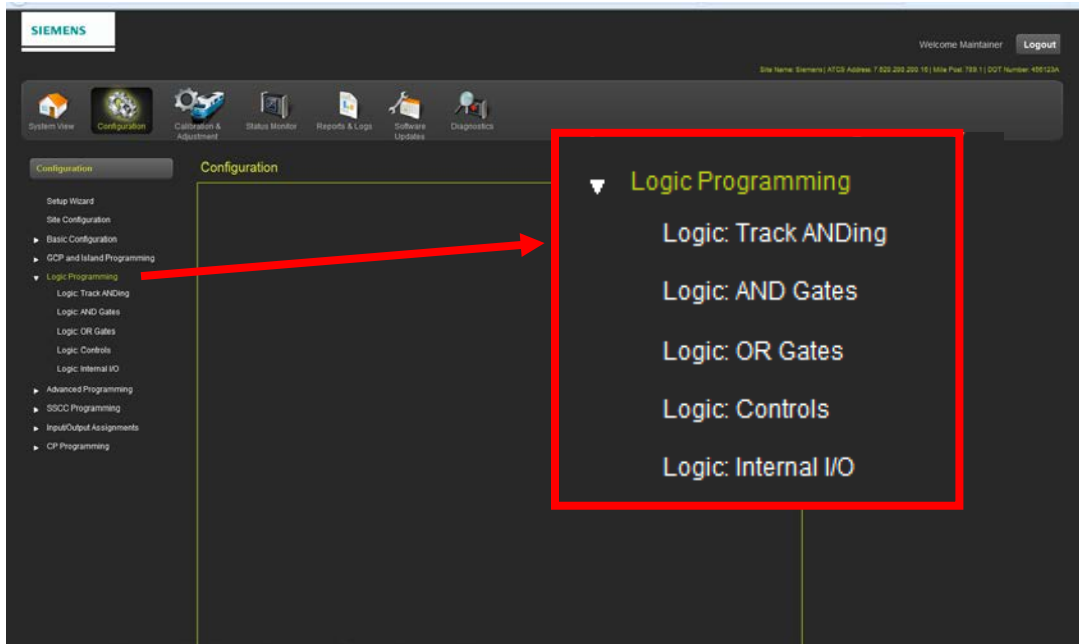

Figure 3-27 CPU III Web UI - GCP5000 Configuration– Logic Programming Menu

### 3.1.2.6 CPU III Web UI – GCP5000 Configuration – Advanced Programming

Advanced Programming menu enables the user to set Bidaxing to RX or TX Approach with options to Vital I/O, Internal PSO, or Center Fed PSO.

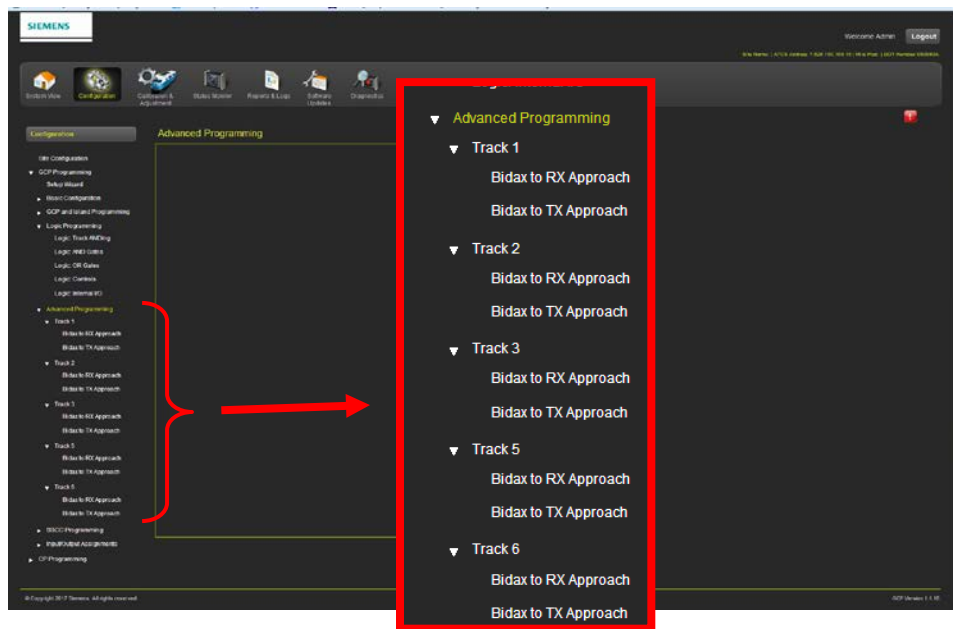

Figure 3-28 CPU III Web UI – GCP5000 Configuration – Advanced Programming Menu

### 3.1.2.7 CPU III Web UI – GCP5000 Configuration – SSCC Programming

The SSCC Window sets the options / levels of the SSCC functions. Use the Arrow buttons at top of the screen to move between the SSCC windows. The options displayed in the window depend on how the SSCCs are being used.

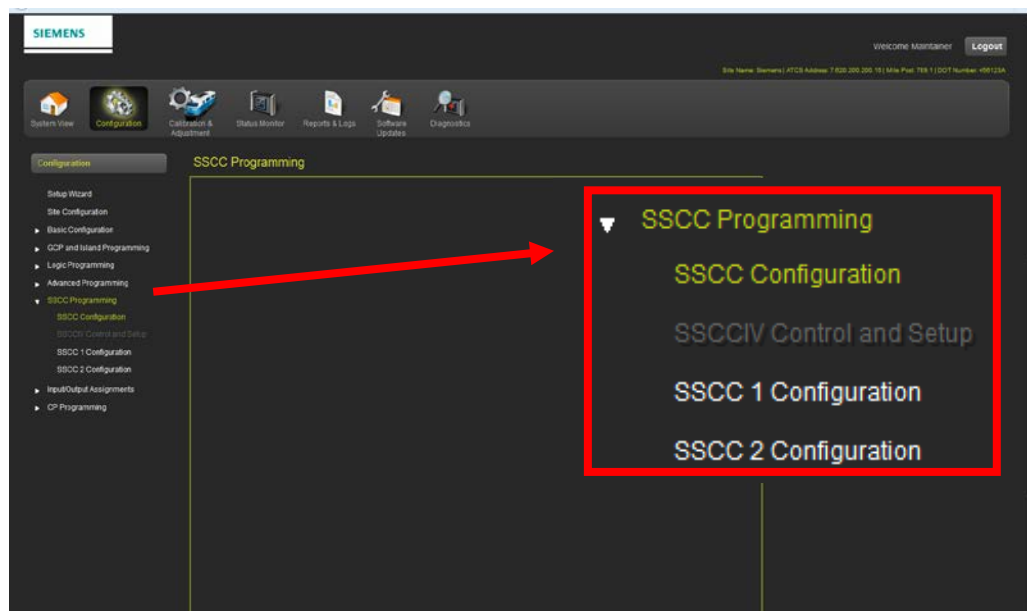

Figure 3-29 CPU III Web UI – GCP5000 Configuration – SSCC Programming Menu

### 3.1.2.8 CPU III Web UI – GCP5000 Configuration – Input/Output Assignments

The Input/Output Assignments screen displays the following links:

- 1) Output Assignments
- 2) Input Assignments

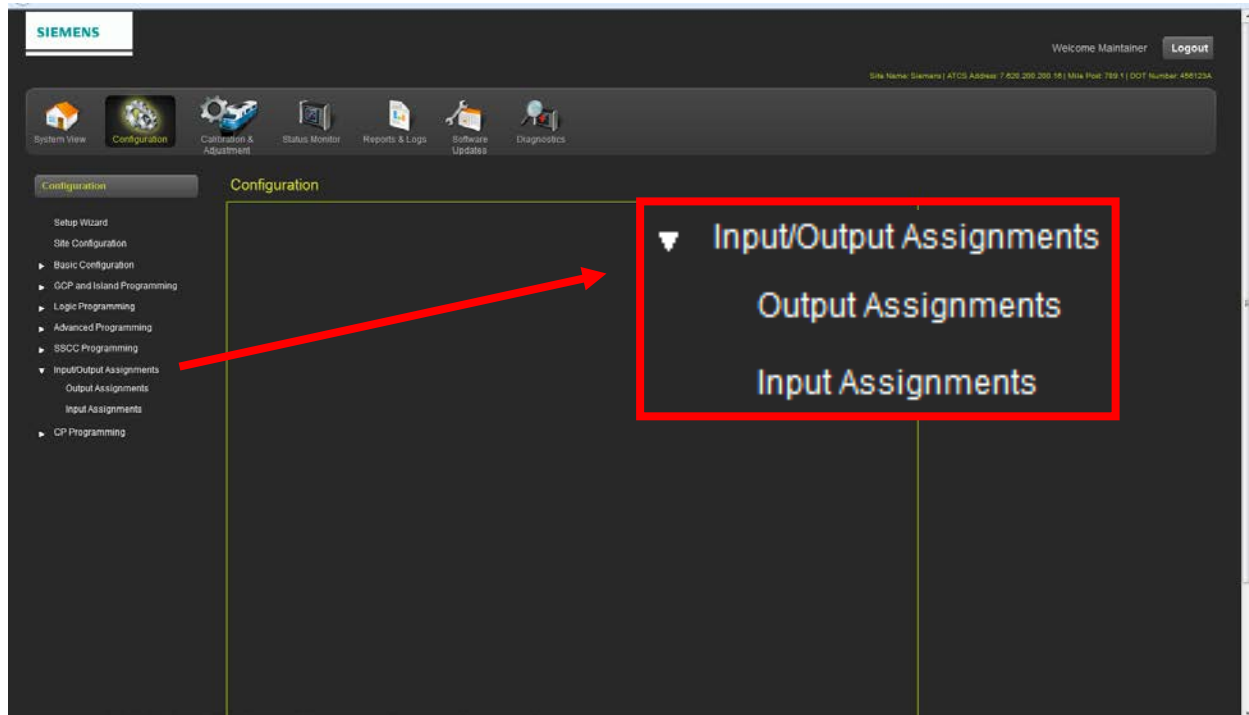

Figure 3-30 CPU III Web UI – GCP5000 Configuration – Input/Output Assignments Menu

### 3.1.2.9 CPU III Web UI – GCP5000 Configuration – CP Programming

The CP Programming menu enables the user to setup the Laptop Port, Log Setup, Security, Web Server, and Set CP parameters to default.

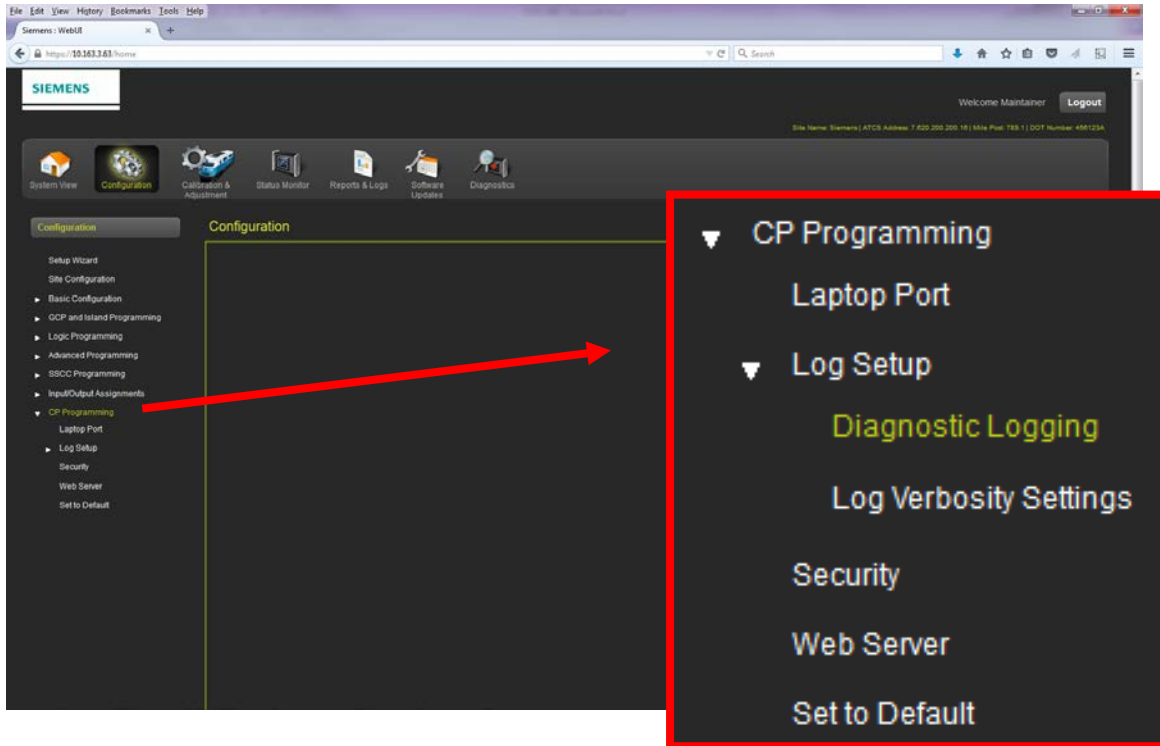

Figure 3-31 CPU III Web UI – GCP5000 Configuration – CP Programming Menu



The Laptop Port menu enables the user to setup the Laptop Port as a Client or Server or may be disabled. Default protocol is DHCP Server with an IP address of 192.168.255.81. The CPU III DHCP Server protocol will assign the laptop an IP address and connect the user to the GCP. If the equipment is to be connected to a network it will be necessary for the user to initially connect to the Web UI using a laptop and configuring the Ethernet port as a Client, failure to do so will cause an interruption of the network since two DHCP servers will be introduced onto the network. In the client mode, the network will assign an IP address to the CPU III. To find the assigned IP Address press the CPU III NAV push button until the display shows the laptop IP address (IP xx.xxx.xxx.xxx). Enter the IP address shown on the display on your Web Browser to connect to the CPU III.

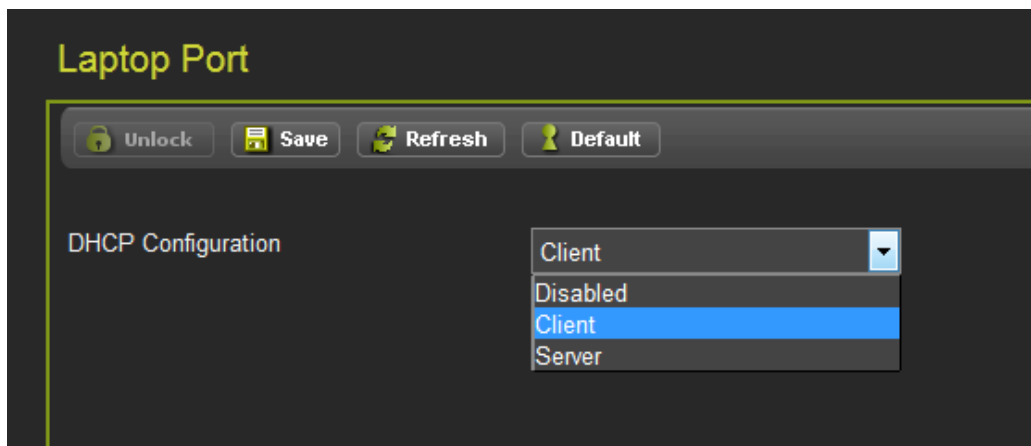
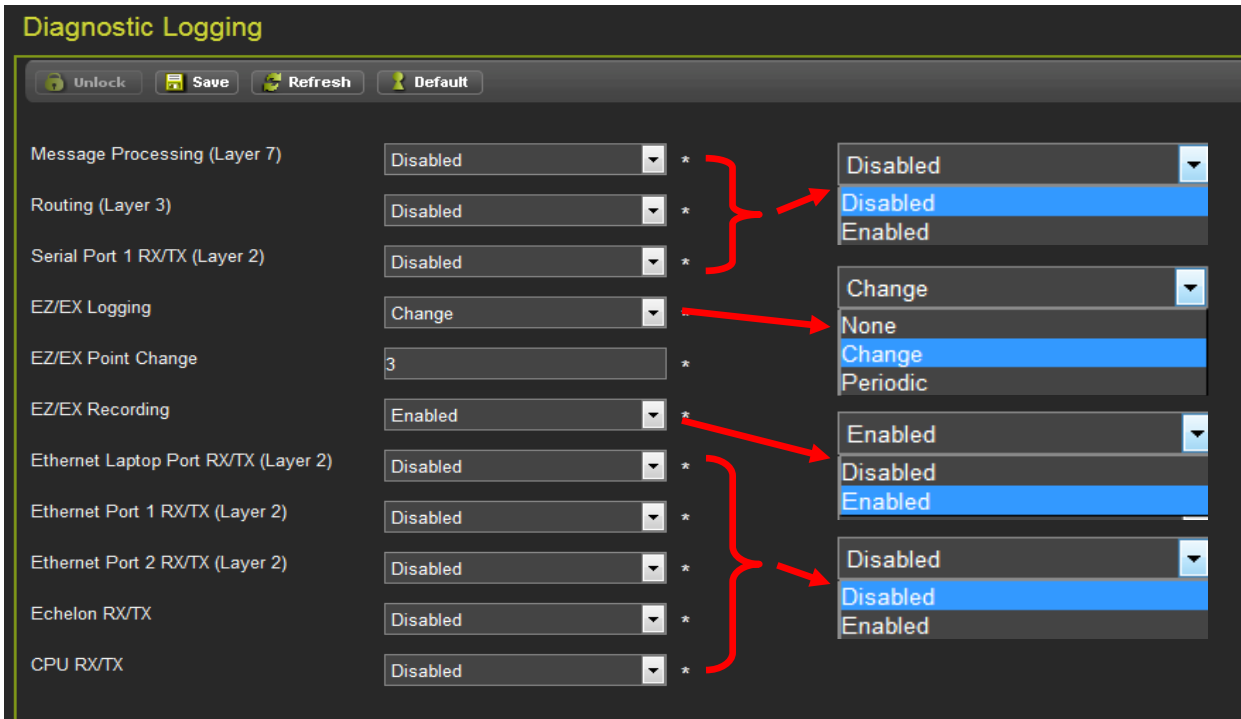

Figure 3-32 CPU III Web UI – GCP5000 Configuration – CP Programming – Laptop Port

The Diagnostic Logging enables the user to setup what information will be logged for Diagnostics and parameters on when to log data. This should only be used by Siemens personnel when troubleshooting a problem as it can result in slower operation of the CP due to logging large amount to the logs.



**Figure 3-33 CPU III Web UI – GCP5000 Config – CP Programming – Diagnostic Logging**

The Log Verbosity Settings provide five settings on how much detail and data will be collected. The maximum setting (Debug) will fill the logging buffer and slow the system response time. This setting should only be used by service personnel in the event of a problem diagnosis session.

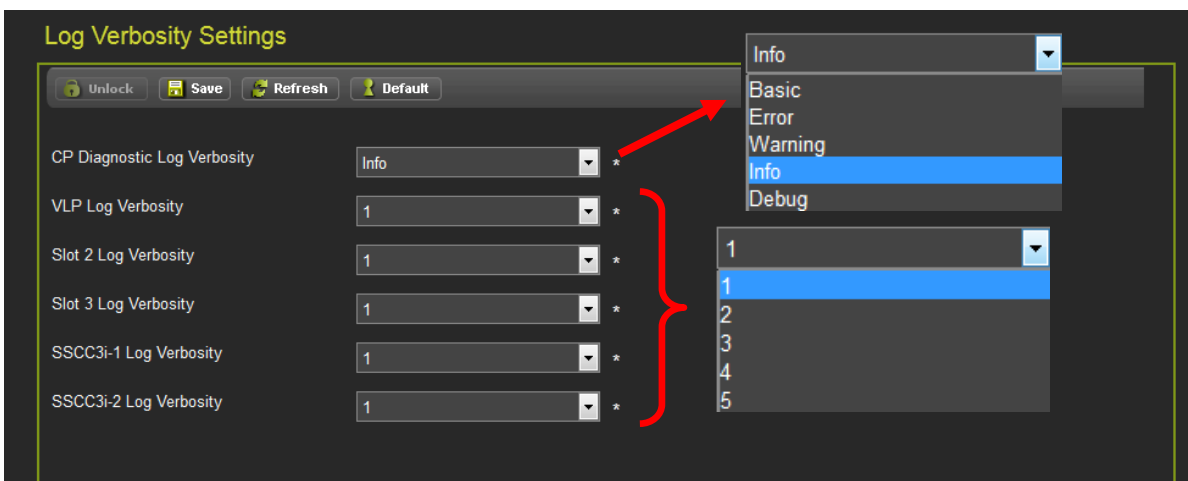

**Figure 3-34 CPU III Web UI – GCP5000 Config – CP Programming –Logging Verbosity**

The Security screen is used to set passwords Maintainer and Supervisor levels as well as enabling and disabling Security. Session activity can be set to re-secure the system after the specified timeout value. This Security is in addition to the Web UI access password.

The Model 5000 GCP has a two tier password system. The two types of passwords are Maintainer Passwords and Supervisor Passwords.

Supervisor Passwords are assigned to senior personnel who design the programming of the GCP. Maintainer passwords are assigned to Field Maintainers.

There are now four methods of access to the 5000 GCP's editable parameters:

- **No Passwords Used:**  
When Security Enabled set to NONE, anyone who gains access to the 5000 GCP can edit any parameter.
- **Maintainer Only used**  
When the Maintainer Only is selected, if the default password is used, no parameters may be edited. If the user logs in as Maintainer with the correct Maintainer Password, all parameters may be edited.
- **Supervisor Only used**  
When the Supervisor Only is selected, if the default password is used, field parameters may be edited but OCCN protected parameters cannot. If the user logs on as Supervisor using the correct Supervisor password, all parameters can be edited.
- **Maintainer or Supervisor selected.**  
When Maintainer or Supervisor is selected, if the default password is used, no parameters may be edited. If the user logs on as Maintainer with the correct Maintainer Password, only those parameters editable by field personnel may be edited. If the user logs on as Supervisor with the correct Supervisor Password, all parameters may be edited.

Information regarding Supervisor Passwords and further discussion of all GCP parameters are found in Siemens Application Guidelines for the Microprocessor Based Grade Crossing Predictor Model 5000 Family, Document Number SIG-00-13-04.

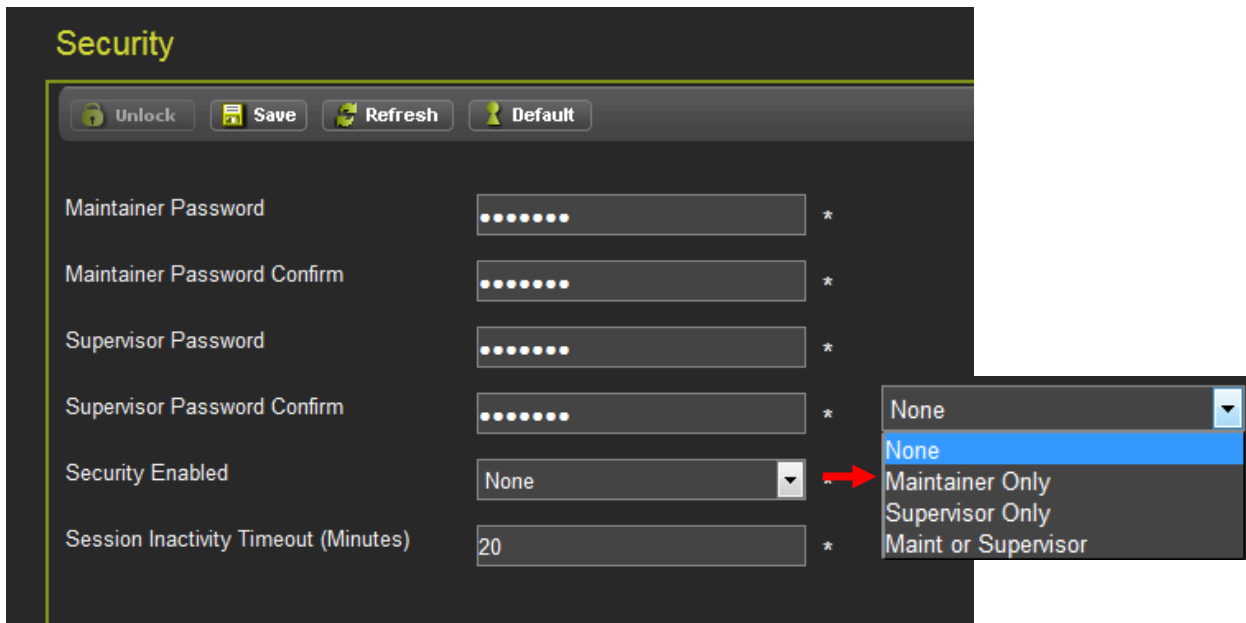

**Figure 3-35 CPU III Web UI – GCP5000 Config – CP Programming –Security**

The Web Server screen enables the user to set Web UI as a secure (https) or non-secured (http) page. Default setting is Secure (https).

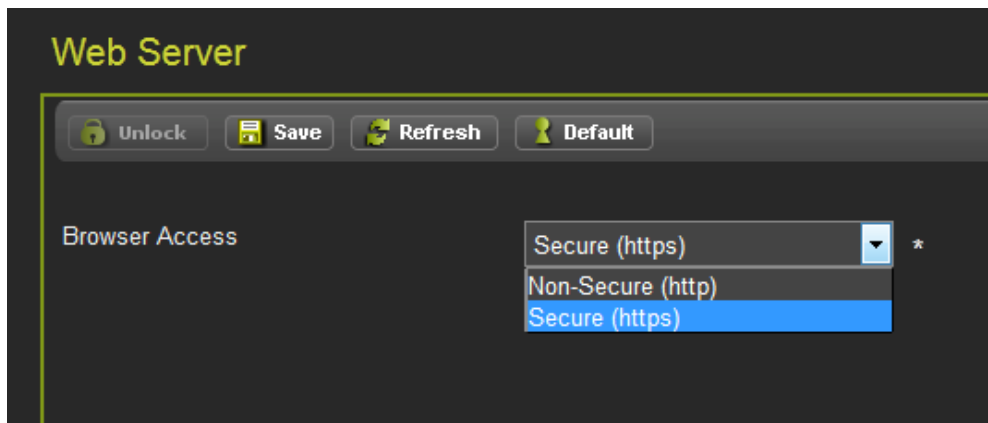

**Figure 3-36 CPU III Web UI – GCP5000 Config – CP Programming –Web Server**

The Set to Default screen enables setting all of the CP Programming parameters to their original factory settings.

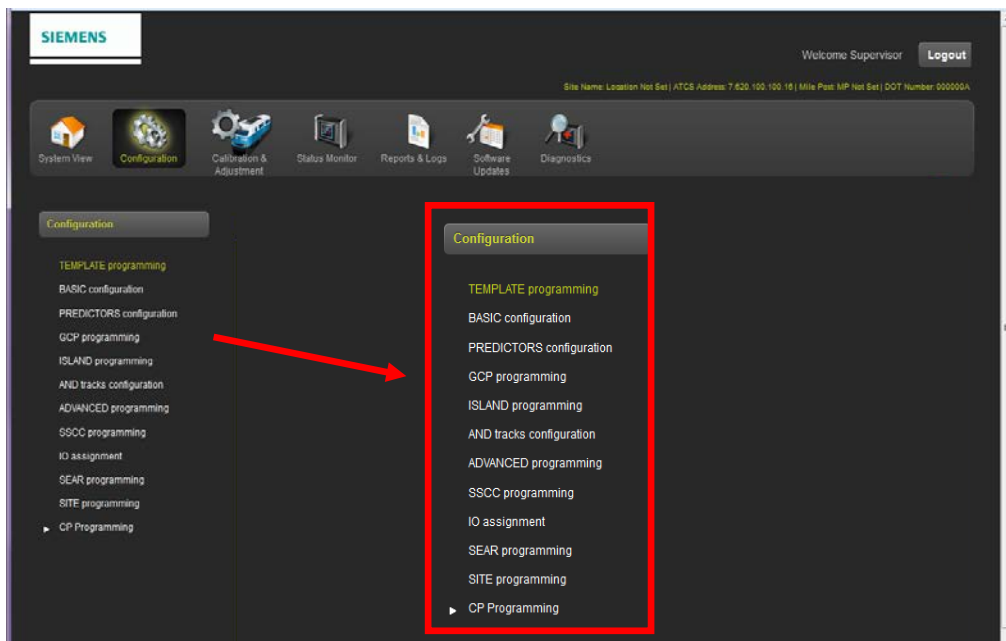

**Figure 3-37 CPU III Web UI – GCP5000 Configuration – CP Programming – Set to Default**

### 3.1.3 CPU III Web UI – GCP4000 Configuration

The Configuration menu on GCP4000 equipment differs from the GCP5000. This section will address the screens of a GCP4000.

The Configuration Menu provides for the configuration and programming of the GCP. The Setup Wizard steps through each of the programming and configuration elements. Separate Menus are available for programming and I/O assignments. The following figures will display the Configuration sub menus.



**Figure 3-38 CPU III Web UI – GCP4000 Configuration Menu**

The Configuration menu screens have Previous and Next buttons to enable the user to navigate step by step through the entire Configuration menu and sub menus. The user can also select the desired menu from the list on the left side of the screen.

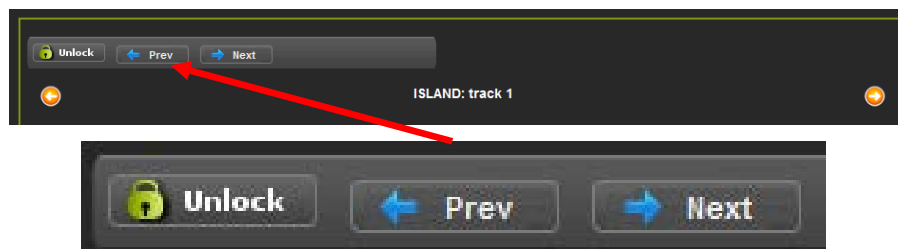

**Figure 3-39 CPU III Web UI – GCP4000 Configuration Menu – Navigation Buttons**

### 3.1.3.1 CPU III Web UI – GCP4000 Configuration – TEMPLATE Programming

The GCP4000 TEMPLATE Programming is shown in the figure below. The user can select from a list of templates to base the system configuration.

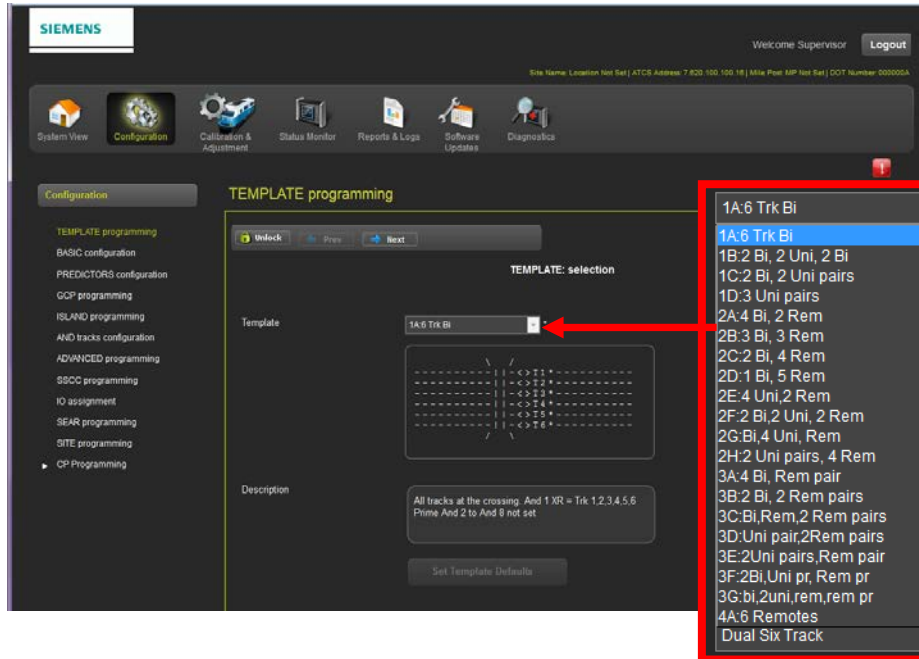

Figure 3-40 CPU III Web UI – GCP4000 Configuration – TEMPLATE Programming

### 3.1.3.2 CPU III Web UI – GCP4000 Configuration – BASIC: Configuration

The BASIC Configuration series of screens starts with the Module Configuration screen, which enables the user to select the modules to be installed in the GCP chassis.

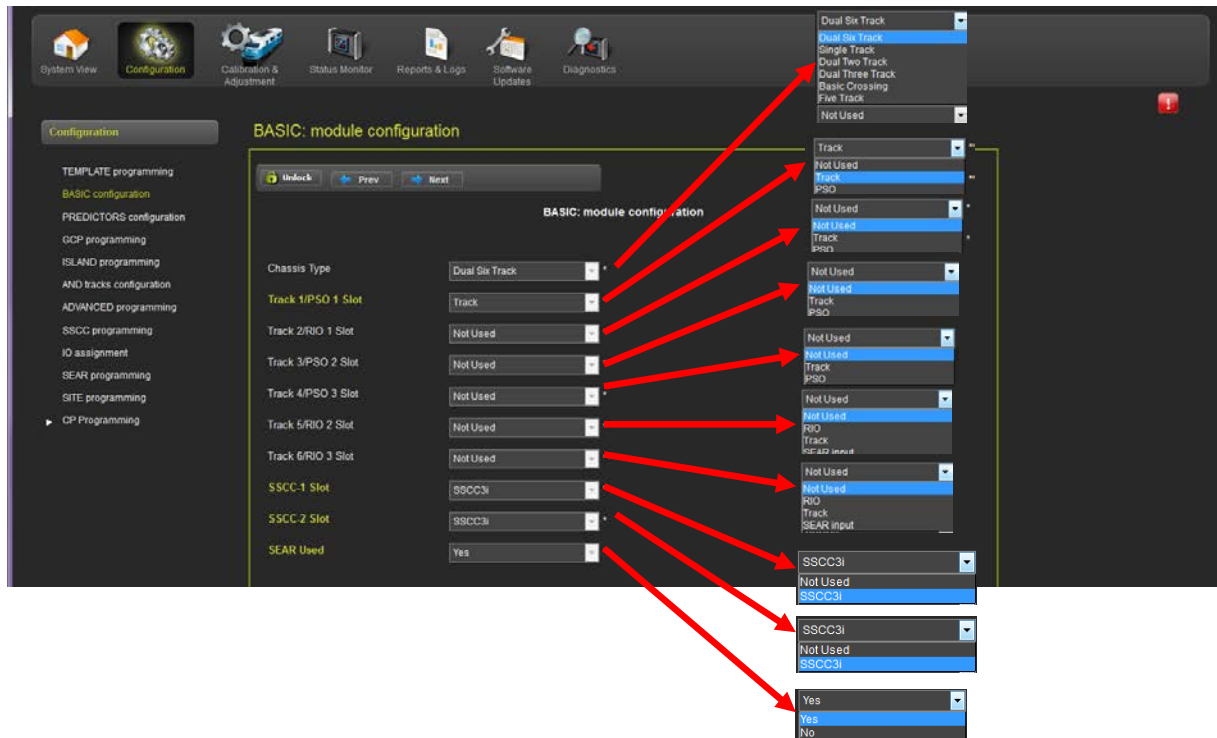

Figure 3-41 CPU III Web UI – GCP4000 Config – BASIC: Config – Module Configuration



### 3.1.1.3.3 CPU III Web UI – GCP4000 Configuration – PREDICTORS Configuration

The Predictors configuration allows the user to select which predictors to use in the application. When the Preempt Logic is set to Advnce or Simult. The Preempt Predictor is also shown here.

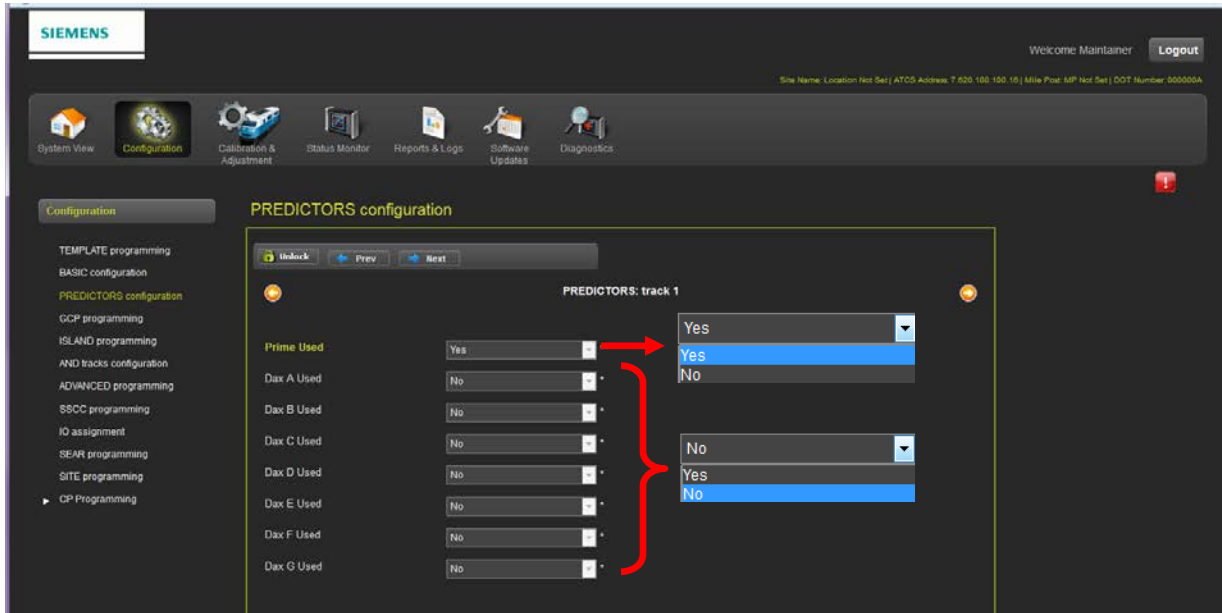

Figure 3-42 CPU III Web UI – GCP4000 Config – PREDICTORS Configuration

### 3.1.3.4 CPU III Web UI – GCP4000 Configuration – GCP Programming

The GCP Programming screen provides the basic parameters for the GCP system as shown in the figure below.

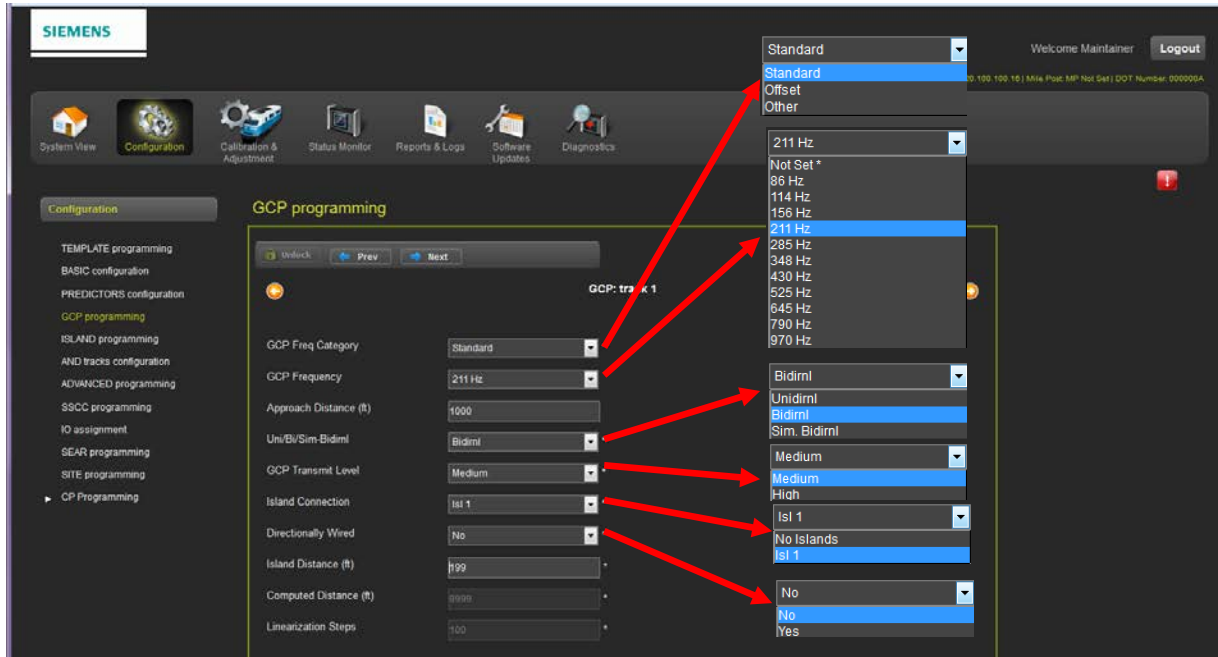

Figure 3-43 CPU III Web UI – GCP4000 Config – GCP Programming

### 3.1.3.5 CPU III Web UI – GCP4000 Configuration – Island Programming

This screen sets the island frequency and pickup delay if IP is set to YES.

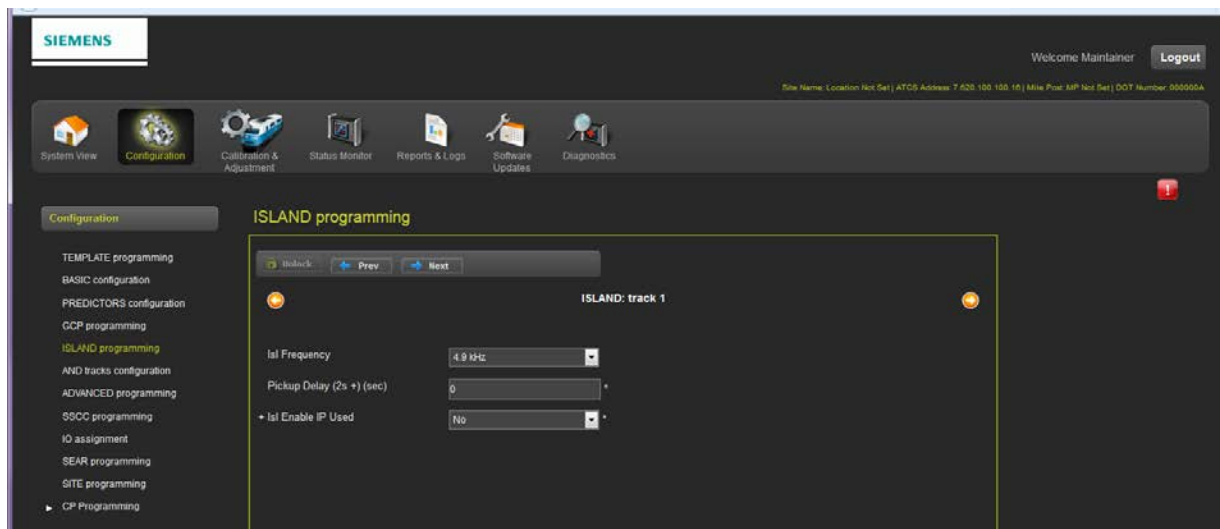

Figure 3-44 CPU III Web UI – GCP4000 Config – ISLAND Programming

### 3.1.3.6 CPU III Web UI – GCP4000 Configuration – AND Tracks Configuration

The AND Tracks configuration screens allows the user to select which AND gates are used that can be used to the AND Track predictor output.

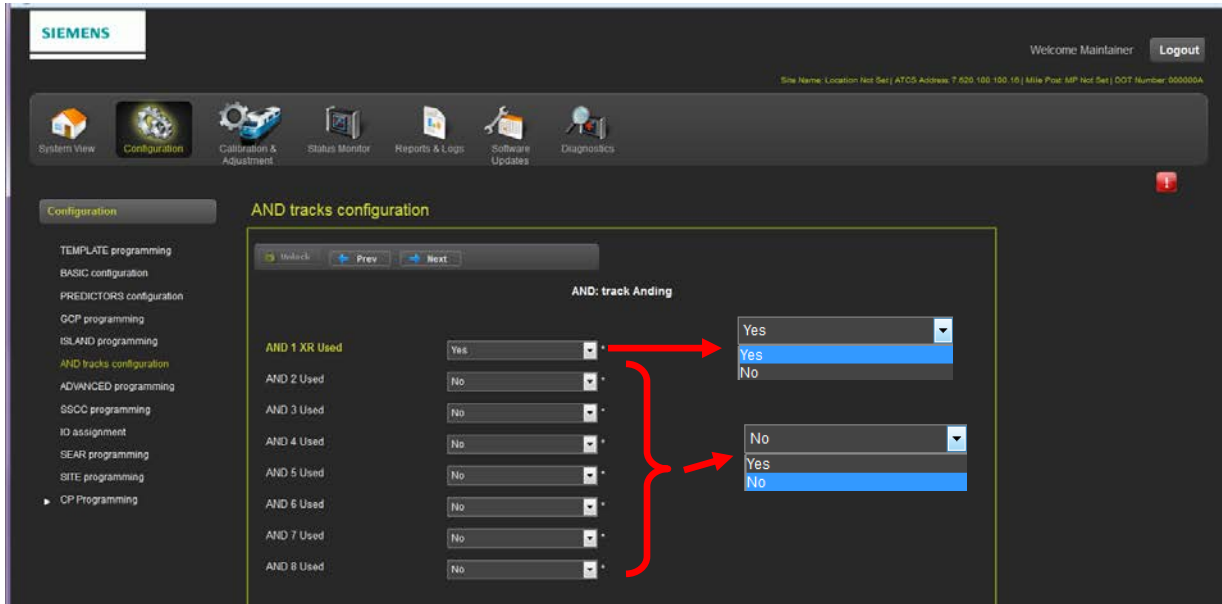

Figure 3-45 CPU III Web UI – GCP4000 Config – AND Tracks Config

### 3.1.3.7 CPU III Web UI – GCP4000 Configuration – ADVANCED Programming

The ADVANCED Programming Menu has seven sub menus as shown in the figure below. Menu can be selected individually or the user can go through the entire series of sub-menus by using the “NEXT” “PREVIOUS” buttons.

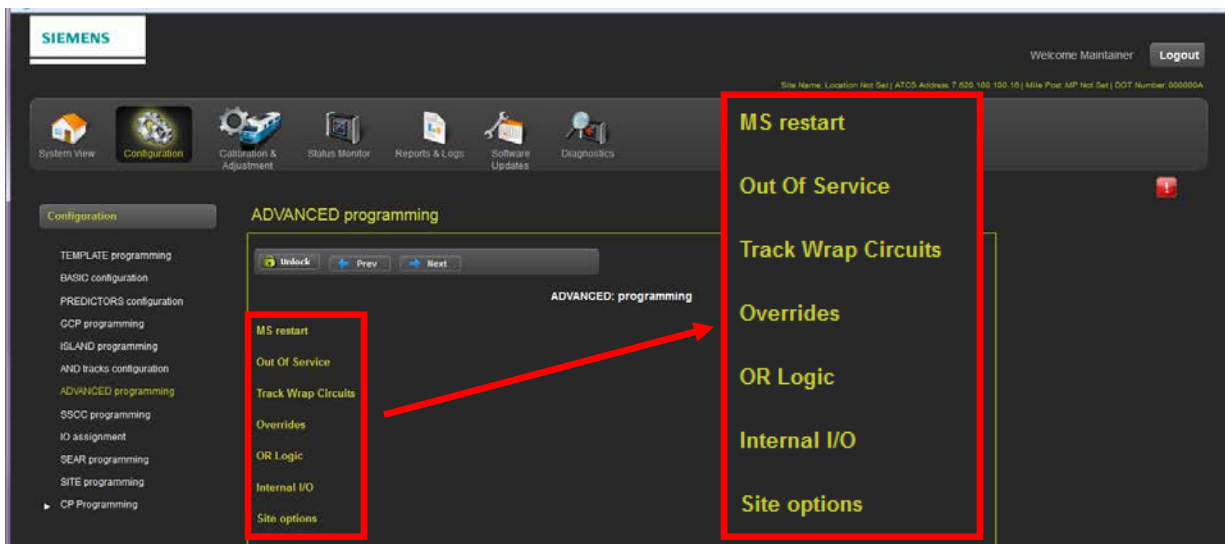

Figure 3-46 CPU III Web UI – GCP4000 Config – ADVANCED Programming Menu

### 3.1.3.8 CPU III Web UI – GCP4000 Configuration – SSCC Programming

The SSCC Programming screen is the first of three screens. This screen enables the user to set parameters related to the crossing controller operation.

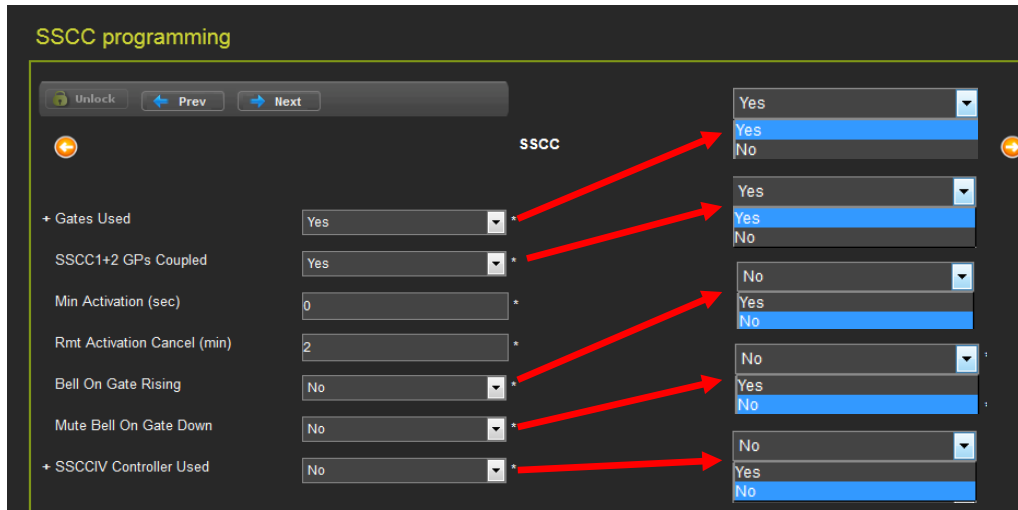

Figure 3-47 CPU III Web UI – GCP4000 Config – SSCC Programming

### 3.1.3.9 CPU III Web UI – GCP4000 Configuration – SEAR Programming

The SEAR programming page allows the user to assign functions to the non-vital inputs and outputs on the front on the SEAR Ili module. It also allows user to set the ATCS Subnode of the SEAR Ili.

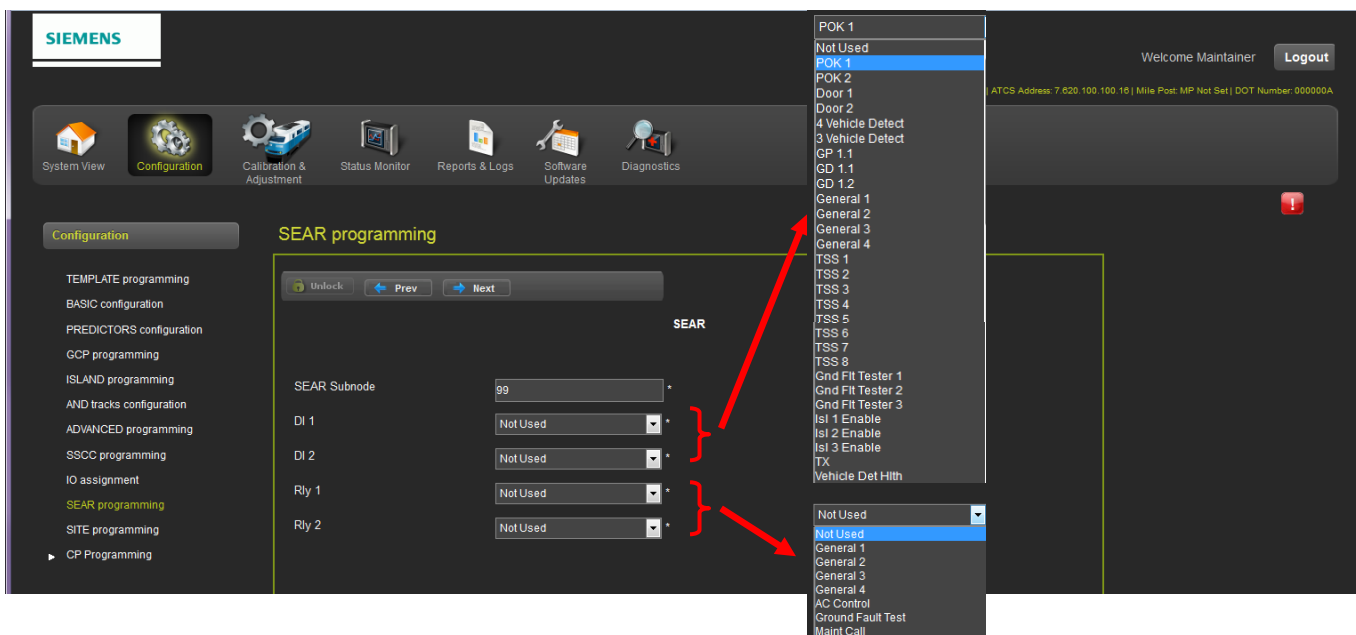

Figure 3-48 CPU III Web UI – GCP4000 Config – SEAR Programming

### 3.1.3.10 CPU III Web UI – GCP4000 Configuration – SITE Programming

The SITE programming screen sets the parameters shown in the figure below.

The screenshot displays the Siemens CPU III Web UI interface for SITE programming. The main configuration area includes fields for Radio Subnode, Field Password, Supervisor Password, and Low Battery Enabled. Below these are fields for ATCS Site Id, Time, and Location. Several pop-up windows are shown, including one for Time Zone selection (Pacific GMT-8:00 is selected) and another for Location details (DOT Crossing Number: 123456, Milepost Number: 32.5, Site Name: CP Siemens). A calendar widget is also visible, showing the date as October 13, 2015.

Figure 3-49 CPU III Web UI – GCP4000 Config – SITE Programming

The Security screen is used to set passwords Maintainer and Supervisor levels as well as enabling and disabling Security. Session activity can be set to re-secure the system after the specified timeout value. This Security is in addition to the Web UI access password.

The Model 4000 GCP has a two tier password system. The two types of passwords are Maintainer Passwords and Supervisor Passwords.

Supervisor Passwords are assigned to senior personnel who design the programming of the GCP. Maintainer passwords are assigned to Field Maintainers.

There are now four methods of access to the 4000 GCP's editable parameters:

- **No Passwords Used:**  
When Security Enabled set to NONE, anyone who gains access to the 4000 GCP can edit any parameter.
- **Maintainer Only used**  
When the Maintainer Only is selected, if the default password is used, no parameters may be edited. If the user logs in as Maintainer with the correct Maintainer Password all parameters may be edited.
- **Supervisor Only used**  
When the Supervisor Only is selected, if the default password is used, field parameters may be edited but OCCN protected parameters cannot. If the user logs on as Supervisor using the correct Supervisor password, all parameters can be edited.
- **Maintainer or Supervisor selected.**  
When Maintainer or Supervisor is selected, if the default password is used no parameters may be edited: if the user logs on as Maintainer with the correct Maintainer Password, only those parameters editable by field personnel may be edited; if the user logs on as Supervisor with the correct Supervisor Password, all parameters may be edited.

Information regarding Supervisor Passwords and further discussion of all GCP parameters are found in Siemens Application Guidelines for the Microprocessor Based Grade Crossing Predictor Model 4000 Family, Document Number SIG-00-08-06.

### 3.1.3.11 CPU III Web UI – GCP4000 Configuration – CP Programming Menu

The CP Programming menu enables the user to setup the Laptop Port, Log Setup, Security, Web Server, and Set all parameters to default.

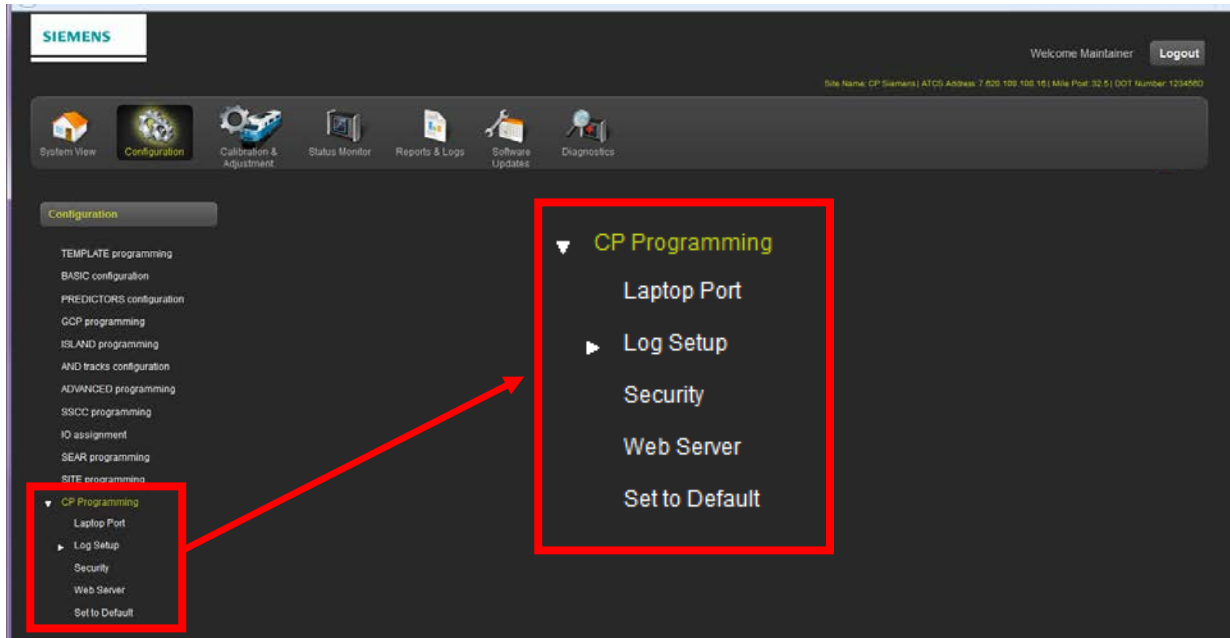

Figure 3-50 CPU III Web UI – GCP4000 Config – CP Programming

#### Laptop Port

The Laptop Port menu enables the user to setup the Laptop Port as a Client or Server or may be disabled. Default IP address for the Laptop Port is 192.168.255.81.

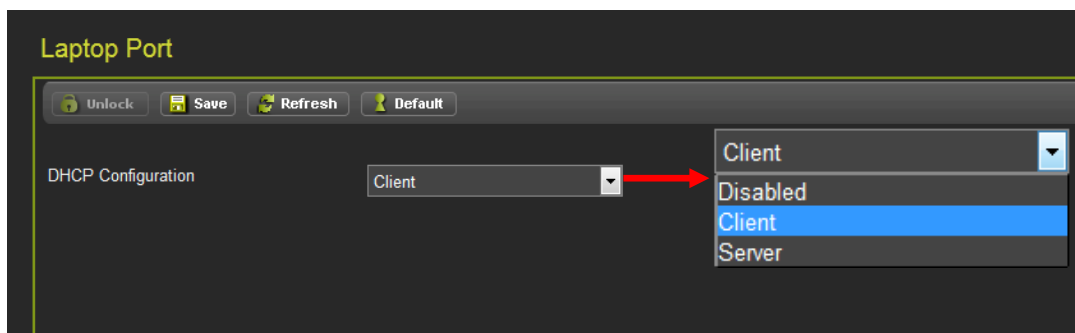

Figure 3-51 CPU III Web UI – GCP4000 Config – CP Programming – Laptop Port

## Diagnostics Logging

The Diagnostic Logging enables the user to setup what information will be logged for Diagnostics and parameters on when to log data. This should only be used by Siemens personnel when troubleshooting a problem as it can result in slower operation of the CP due to logging large amount to the logs.

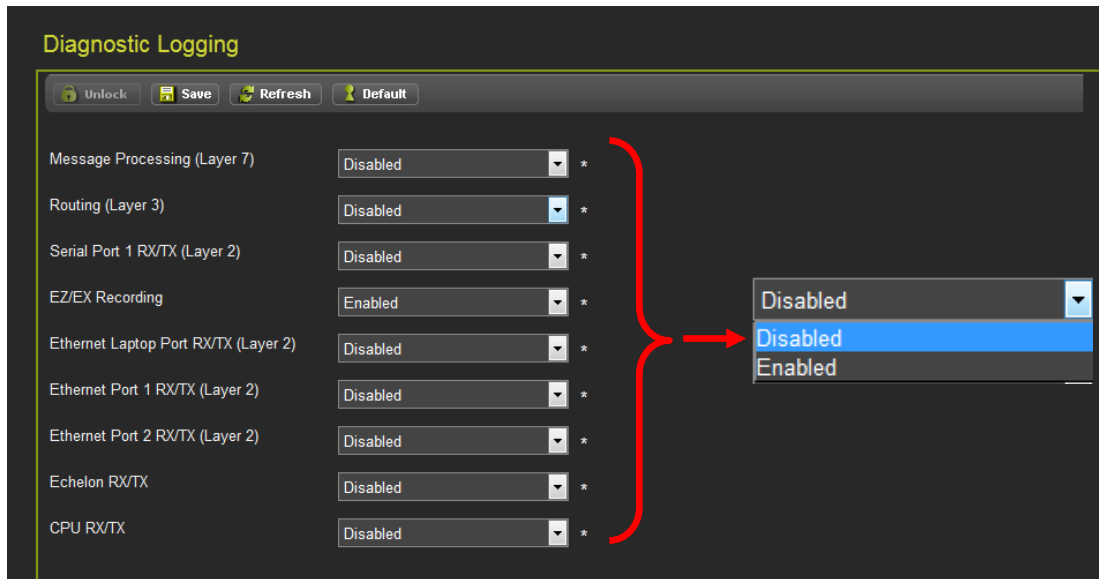

Figure 3-52 CPU III Web UI – GCP4000 Config – CP Prog – Log Setup – Diagnostic Log

## Log Verbosity Settings

The Log Verbosity Settings provide five settings on how much detail and data will be collected. The maximum setting (Debug) will fill the logging buffer and slow the system response time. This setting should only be used by service personnel in the event of a problem diagnosis session.

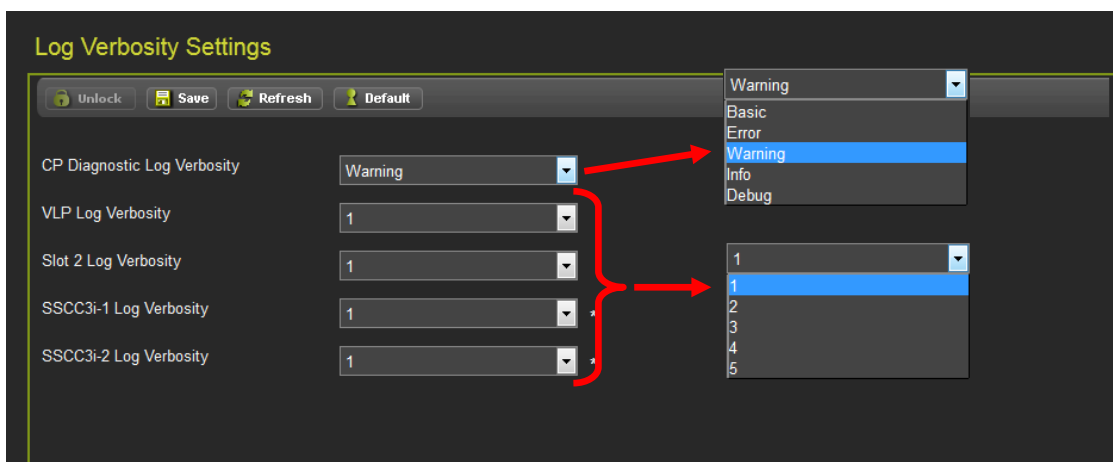

Figure 3-53 CPU III Web UI – GCP4000 Config – CP Prog – Log Setup – Verbosity



### 3.1.3.12 CPU III Web UI – GCP4000 Configuration – CP Programming - Security

The Security screen sets the session inactivity timer.

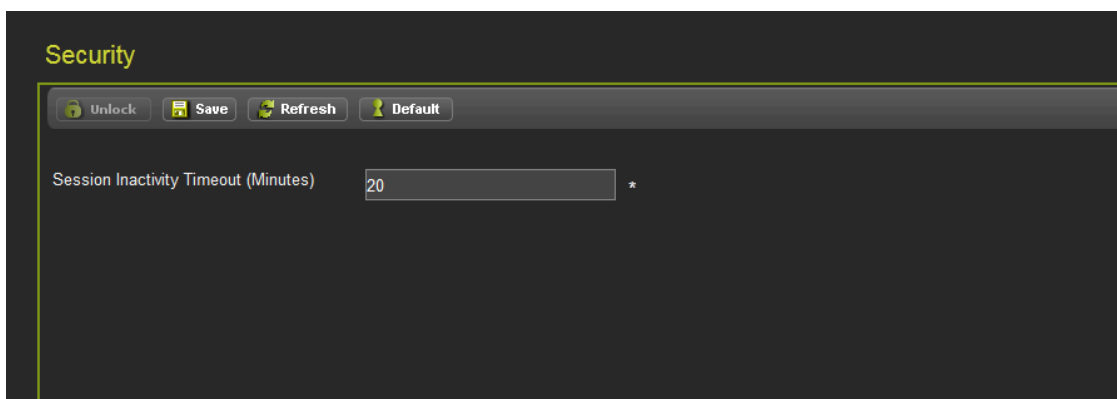

Figure 3-54 CPU III Web UI – GCP4000 Config – CP Prog – Security

### 3.1.3.13 CPU III Web UI – GCP4000 Configuration – CP Programming – Web Server

The Web Server screen enables the user to set Web UI as a secure (https) or non-secured (http) page. Default setting is Secure (https).

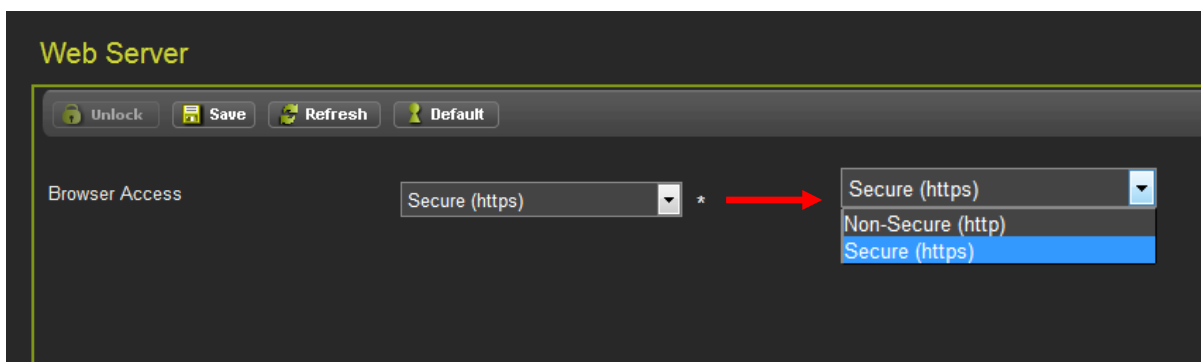
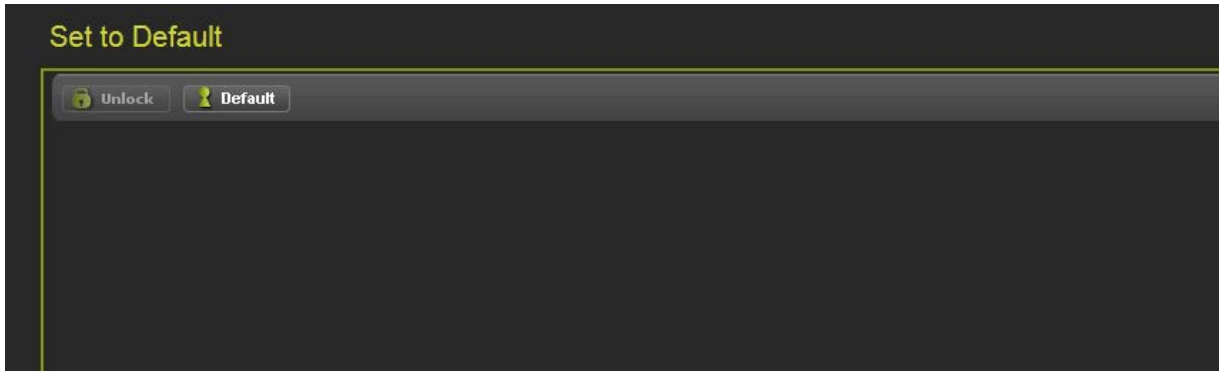

Figure 3-55 CPU III Web UI – GCP4000 Config – CP Prog – Web Server

### 3.1.3.14 CPU III Web UI – GCP4000 Configuration – CP Programming – Set to Default

The Set to Default screen enables setting all of the CP Programming parameters to their original factory settings.



**Figure 3-56 CPU III Web UI – GCP4000 Config – CP Prog – Set to Default**

### 3.1.4 CPU III Web UI – GCP Calibration and Adjustment

The Calibration and Adjustment menu has two sub menus Track/PSO and SSCC. The Track/PSO menu has sub menus for Track Setup, Calibration, and Remote Setup. The SSCC menu has sub menus for Lamp Adjustment SSCC Test, and Remote Setup.

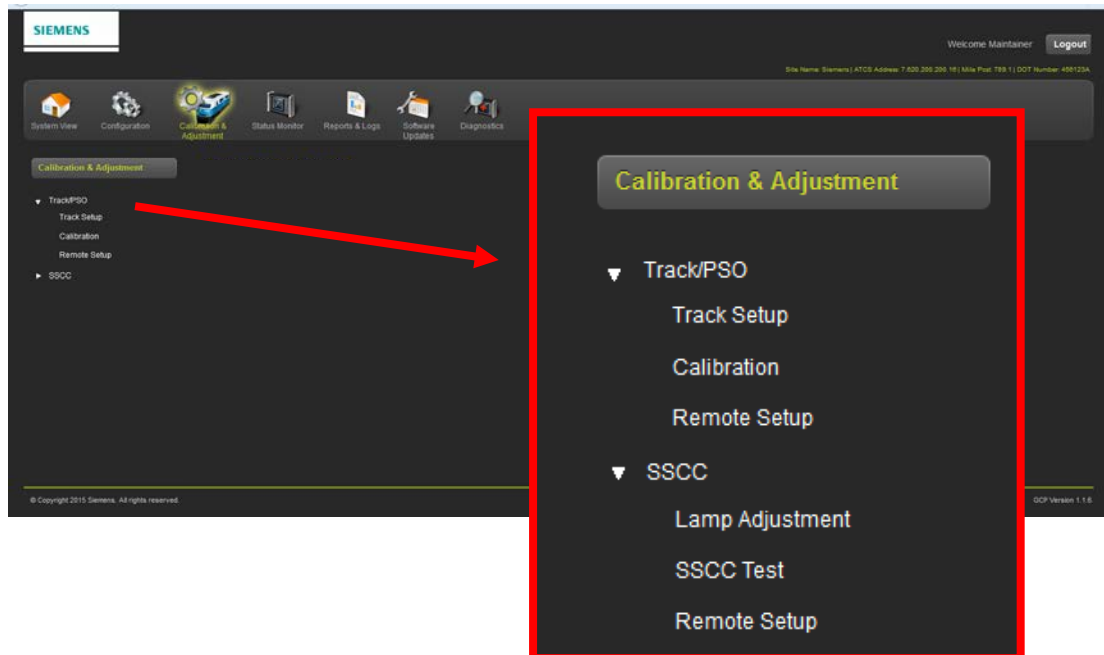

Figure 3-57 CPU III Web UI – Calibration & Adjustment Menu

### 3.1.4.1 CPU III Web UI – Calibration and Adjustment – Track/PSO

#### Track Setup

The Track Setup screen enables the user to change track and island setup parameters. Refer to the GCP manuals for programming and setup parameters and procedures. Normally these parameters will not require adjustment unless changes are required in the system setup.

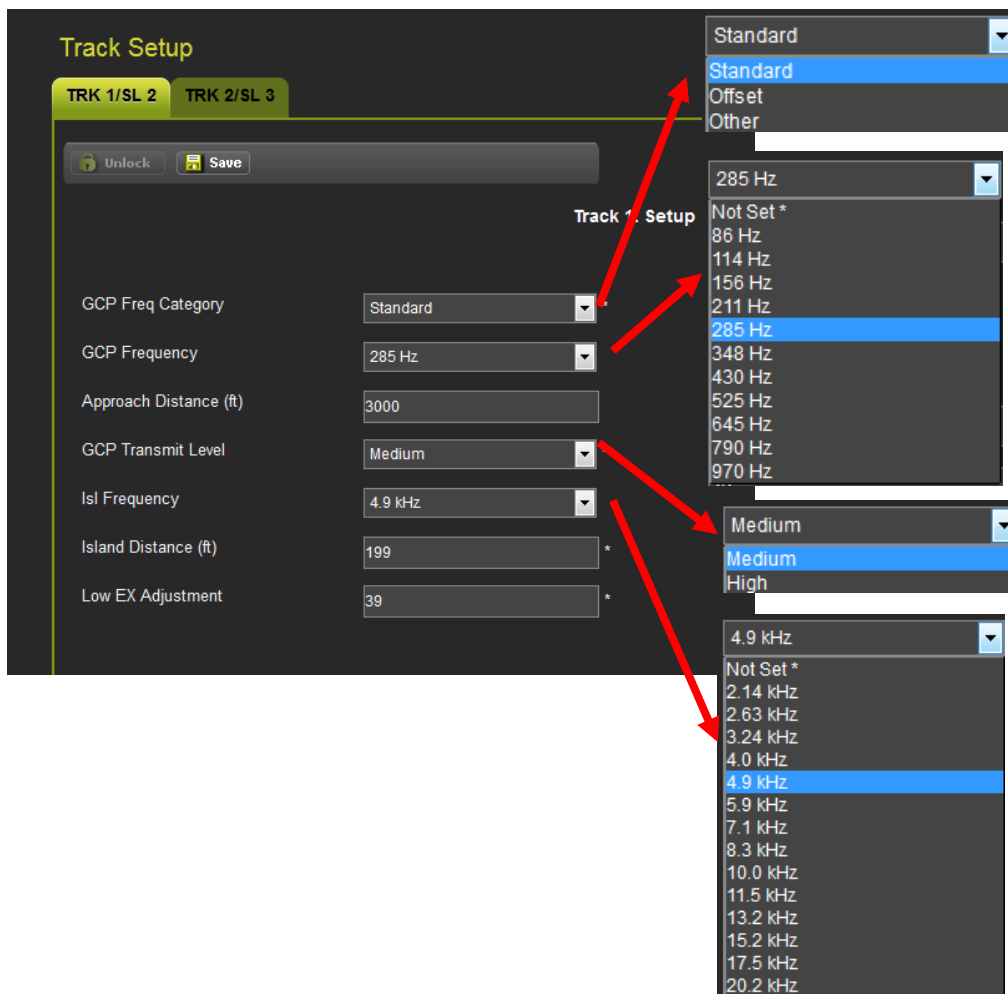
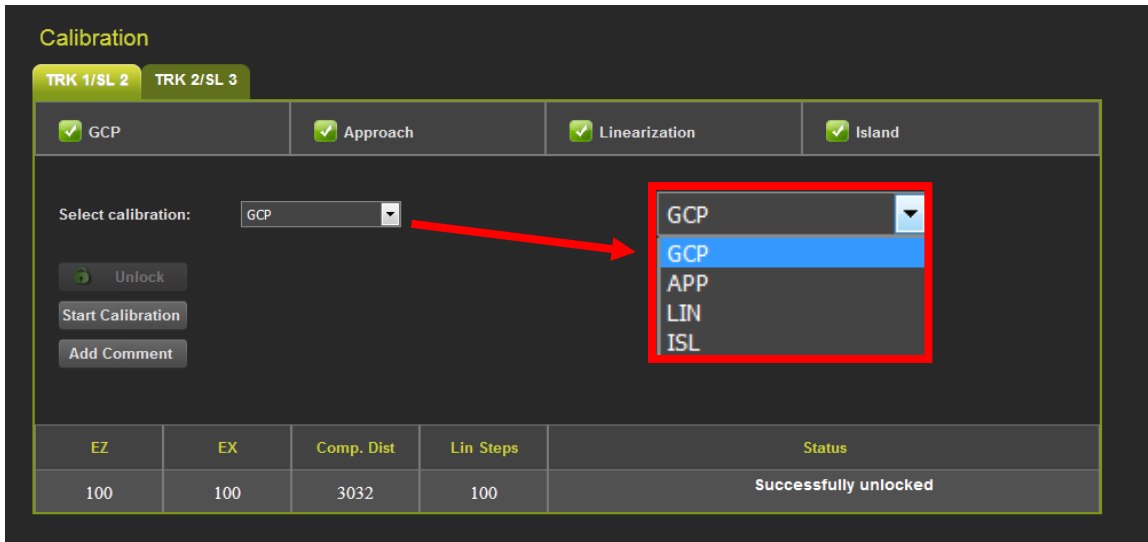

Figure 3-58 CPU III Web UI – Calibration & Adjustment – Track/PSO – Track Setup

## Calibration

The Calibration screen displays a tab for each Track/Island programmed into the system. A drop menu for GCP, Approach, Linearization, and Island, each may be selected for Calibration or Editing. The user can also add comments to each selection.



**Figure 3-59 CPU III Web UI – Calibration & Adjustment – Track/PSO – Calibration**

To Calibrate, select the drop menu GCP, Approach, Linearization, or Island. Click on the Start Calibration button, the status window will show “Processing...” when the calibration is complete the status window will display “Calibration Success” or “Calibration Fail”.

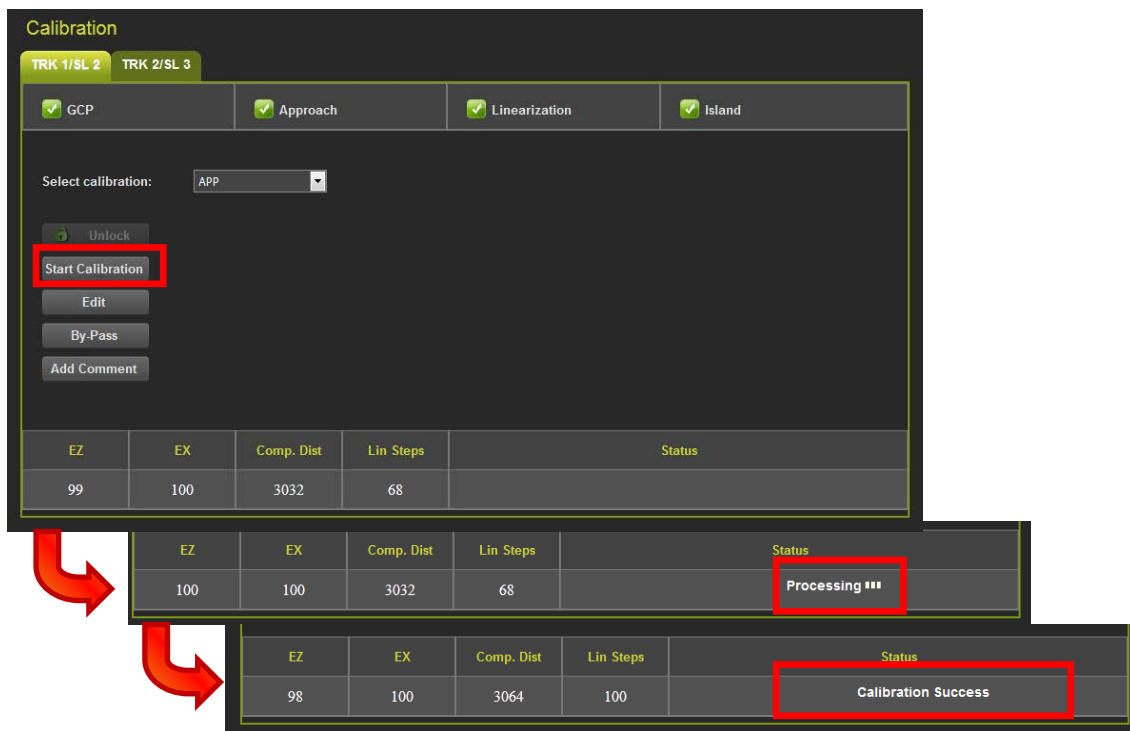

**Figure 3-60 CPU III Web UI – Calibration & Adjustment – Track/PSO – Start Calibration**

If a calibration fails the Status window will display “Calibration Failed”, the application icon will turn red, and the Diagnostic Alert Icon will appear in the upper right corner. A Diagnostic message will be displayed on the Diagnostic screen with information of the failure (see Section 3.1.8).

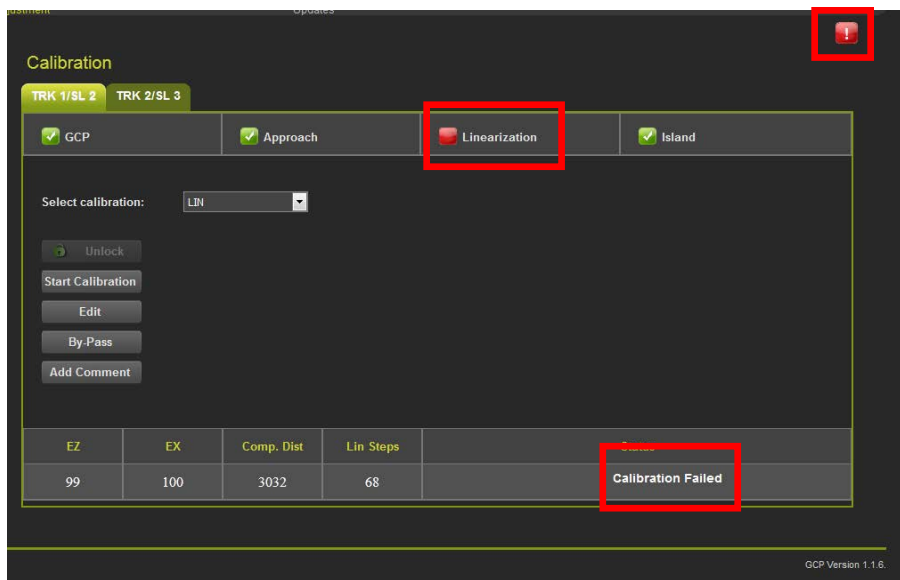

**Figure 3-61 CPU III Web UI – Calibration & Adjustment – Track/PSO – Calibration Fail**

Calibration may be Bypassed by selecting the By-Pass button. The request will be processed and the Status window will display “Calibration bypassed successfully”.

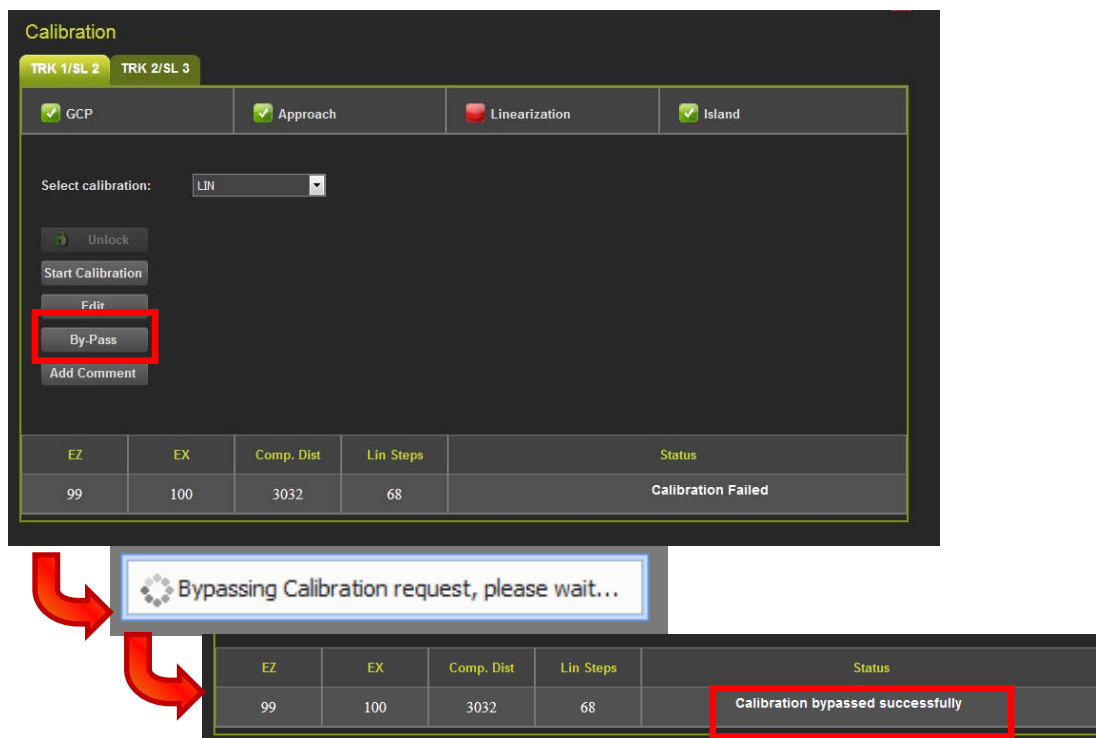

**Figure 3-62 CPU III Web UI – Calib & Adjustment – Track/PSO – Calibration Bypass**

The computed distance can be edited by selecting the Edit button [1]. A pop-up window will appear with text box to change the distance value [2]. When completed, click on the Update button [3] to save the new value.

The screenshot displays the 'Calibration' interface for 'TRK 1/SL 2' and 'TRK 2/SL 3'. It includes a table with columns for 'EZ', 'EX', 'Comp. Dist', 'Lin Steps', and 'Status'. The 'Edit' button is highlighted with a red box and the number '1'. A red arrow points from this button to a pop-up window. The pop-up window contains a text box for 'Computed Distance (ft)' with the value '3120' and is also highlighted with a red box and the number '2'. Below the text box are 'Update' and 'Cancel' buttons, with the 'Update' button highlighted by a red box and the number '3'.

EZ	EX	Comp. Dist	Lin Steps	Status
100	100	3032	68	

EZ	EX	Comp. Dist	Lin Steps	Status
100	100	3032	68	

Figure 3-63 CPU III Web UI – Calibration & Adjustment – Track/PSO – Calibration Edit

## Track/PSO Remote Setup

The remote monitoring and calibration operation function allows the GCP to be monitored and calibrated from any location in the GCP approaches. This calibration operation is generally conducted outside of the bungalow using the Siemens VHF Communicator and a compatible VHF Radio with a touchtone pad. The maintainer outside the bungalow uses the radio, sending touchtone codes to the GCP, which in turn sends audible responses to the maintainer to perform setup procedures

The screen below displays the Track/PSO Remote Setup screen. To view the remote setup information, Unlock the system, the Get button [1] will appear, click the Get button [1] and a pop-up screen will appear click the OK button [2]. Acknowledgement is required from the on-site person (who will acknowledge the request by pressing the Select (SEL) button on the CPU III). When acknowledgement is received a pop-up screen will appear advising the request is being processed. A new screen [4] will appear with the remote setup information.

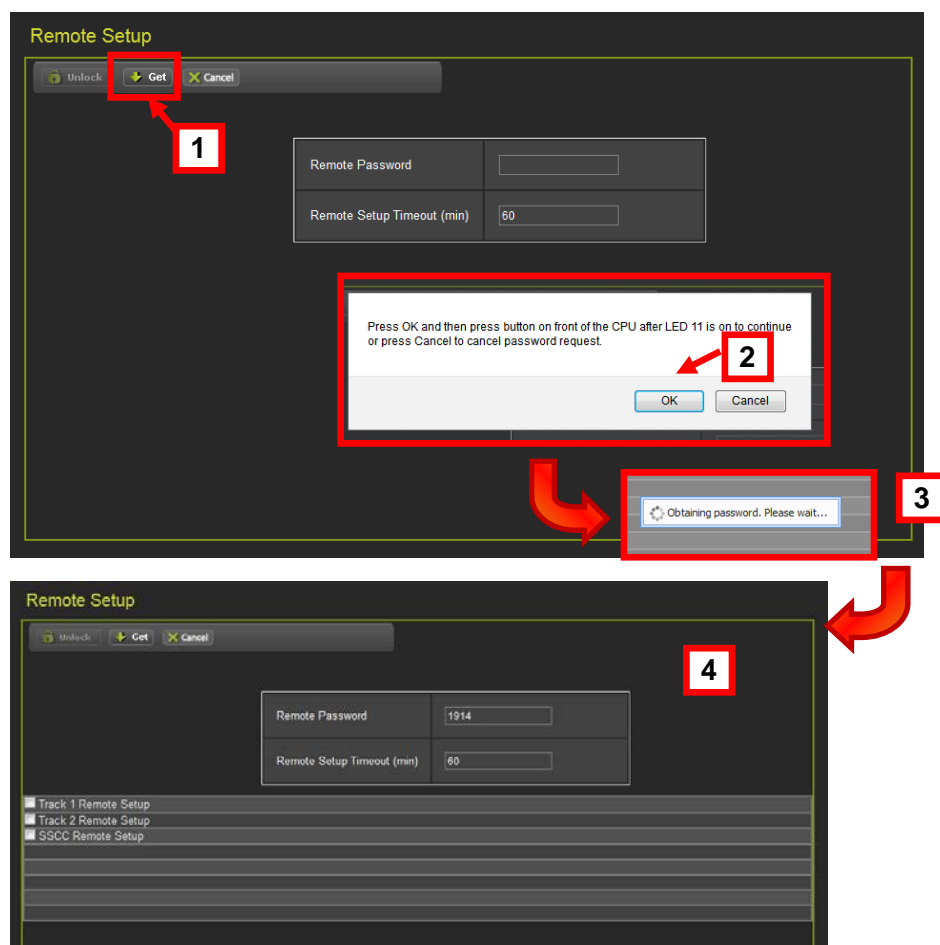

Figure 3-64 CPU III Web UI – Calibration & Adjustment – Track/PSO – Remote Setup



### 3.1.4.2 CPU III Web UI – Calibration and Adjustment – SSCC

The first sub-menu of the SSCC is Diagnostics. Any active alarms will display on this screen. The Diagnostic Alert icon will be present in the upper right corner. See Section 3.1.8.

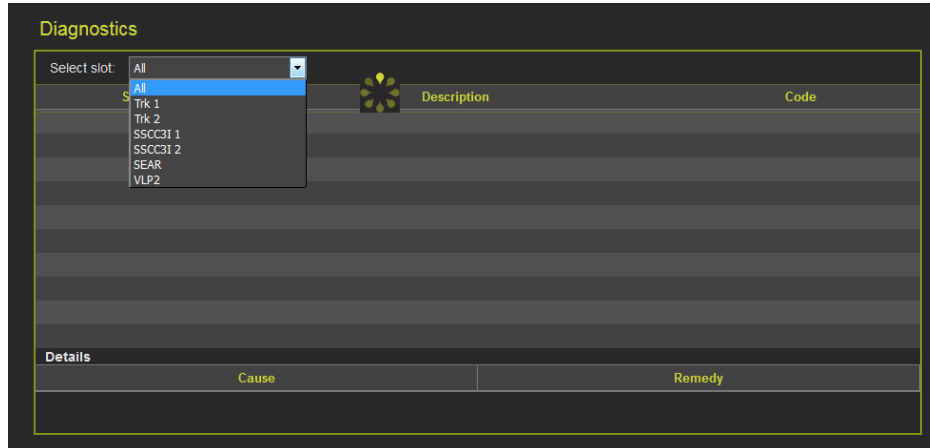

Figure 3-65 CPU III Web UI – Calibration & Adjustment – SSCC - Diagnostics

### Lamp Adjustment

This screen enables the user to adjust the lamp voltage for SSCC 1 and SSCC 2.

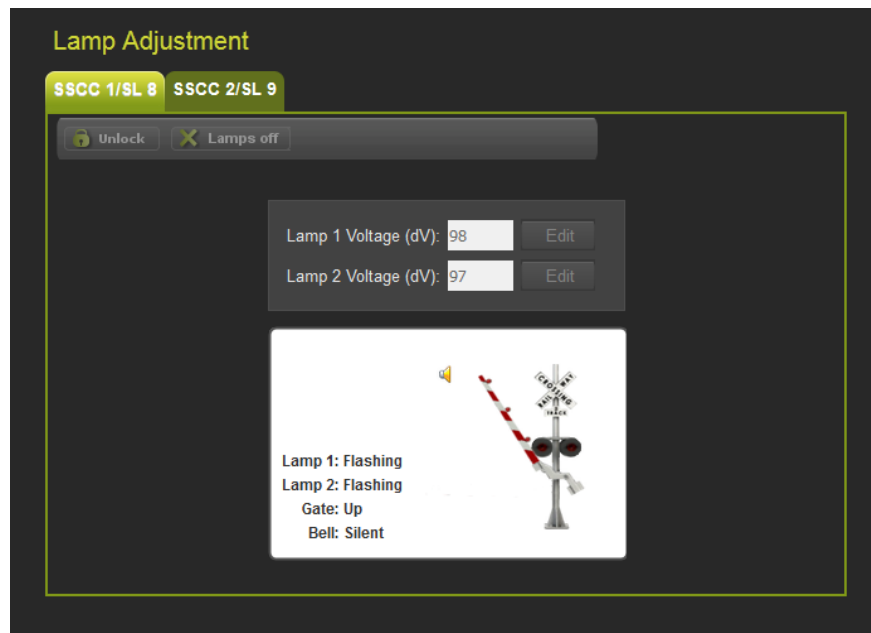

Figure 3-66 CPU III Web UI – Calibration & Adjustment – SSCC – Lamp Adjustment

## SSCC Test



**WARNING**

**ENSURE ALL SAFETY PROCEDURES ESTABLISHED BY THE GOVERNING RAILROAD AND/OR AUTHORITY ARE PERFORMED FOR THE SAFETY OF VEHICULAR TRAFFIC, PEDESTRIANS, AND TRAINS WHEN PERFORMING THE FOLLOWING TESTS.**

The SSCC Test menu has the following Test sequences that can be initiated by the user:

- Bell – Initiates bell
- Lamp 1 – Turns lamp 1 on steady
- Lamp 2 – Turns lamp 2 on steady
- Flash the Lamps – Sets the lamps to flashing
- Test the Crossing – Test full crossing operation (turn on bell and lights, after gate delay drop the gate)
- Perform a Timed Test – After a time-1 delay, flashes lamps for a time-2 delay, then turns them off
- Perform a Repeat Test – After a time-1 delay, flashes the lamps for time-2 delay, then turns them off for twice the time-1 delay, then flashes the lamps again for the time-2 delay then turns them off
- Time-1 and Time-2 above are user configurable delay times

These tests will test the crossing selected crossing operation independent of train occupation as defined by each test parameters.

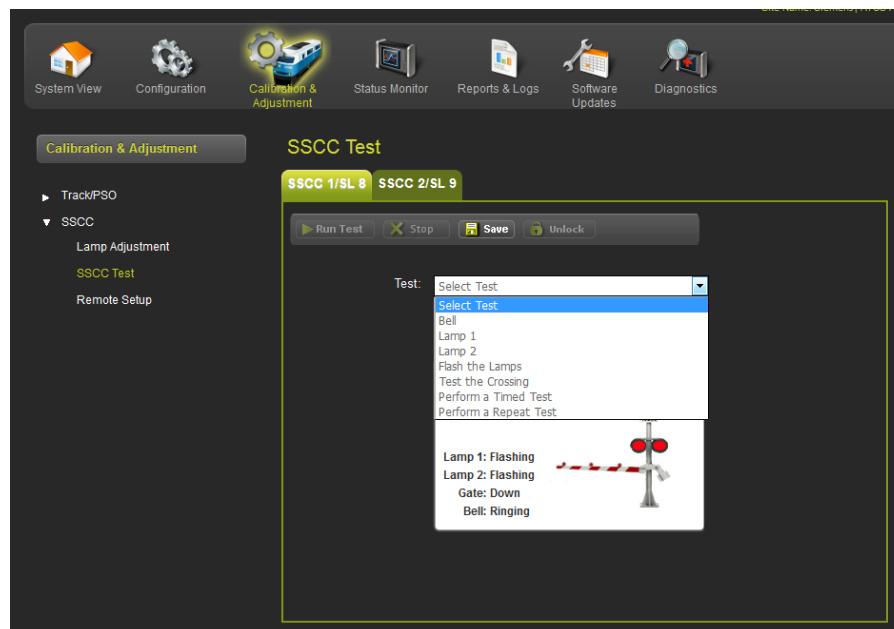

Figure 3-67 CPU III Web UI – Calibration & Adjustment – SSCC – SSCC Tests

The figure below displays the SSCC Test screens.



Figure 3-68 CPU III Web UI – Calibration & Adjustment – SSCC – SSCC Test Screens

## SSCC Remote Setup

The SSCC Remote Setup function allows the GCP to be monitored and calibrated from any location in the GCP approaches. This calibration operation is generally conducted outside of the bungalow using the Siemens VHF Communicator and a compatible VHF Radio with a touchtone pad. The maintainer outside the bungalow uses the radio, sending touchtone codes to the GCP, which in turn sends audible responses to the maintainer to perform setup procedures

The SSCC Remote Setup screen enables the user to set the password (using numbers which will be sent from the touchtone keypad on the VHF radio for remote access of the SSCC). To access the information the system must be unlocked [1], a confirmation pop-up will appear [2] press OK an on-site person will push the Select (SEL) button to acknowledge the request. The unlock button will dim and the Get and Cancel buttons illuminate, press the 'GET' [3] button, another confirmation pop-up will appear, press the OK [4] button, a request will go out to the CPU III module and an on-site person will push the Select (SEL) button to acknowledge the request. Another screen will come up with the password and timeout information.

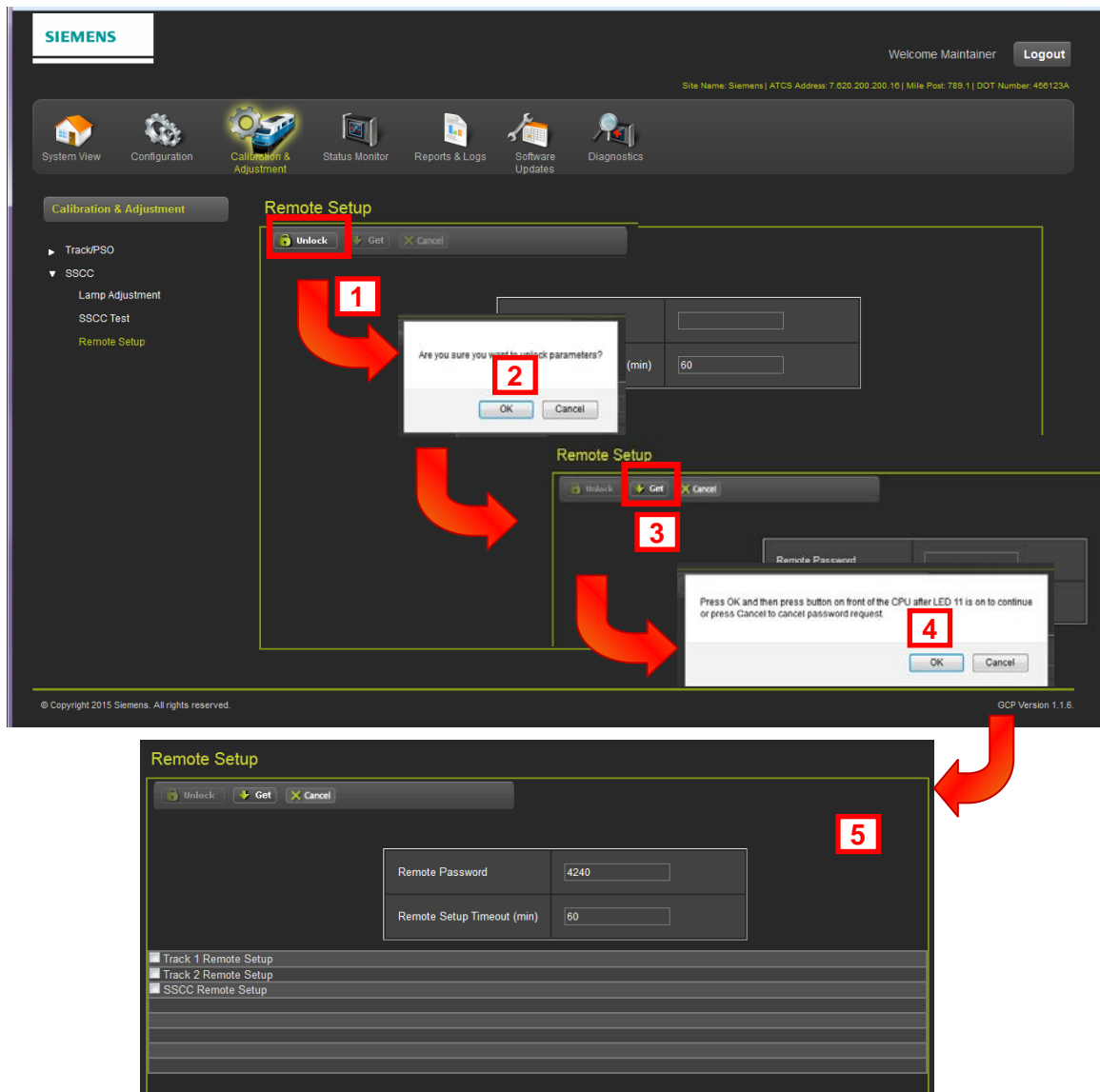

Figure 3-69 CPU III Web UI – Calibration & Adjustment – Track/PSO – Remote Setup

### 3.1.5 CPU III Web UI – GCP Status Monitor

The Status Monitor provides screens for I/O View, Logical View, Module I/O View, Comm View, Logic States, Ethernet Status, Route Table, and Statistics.

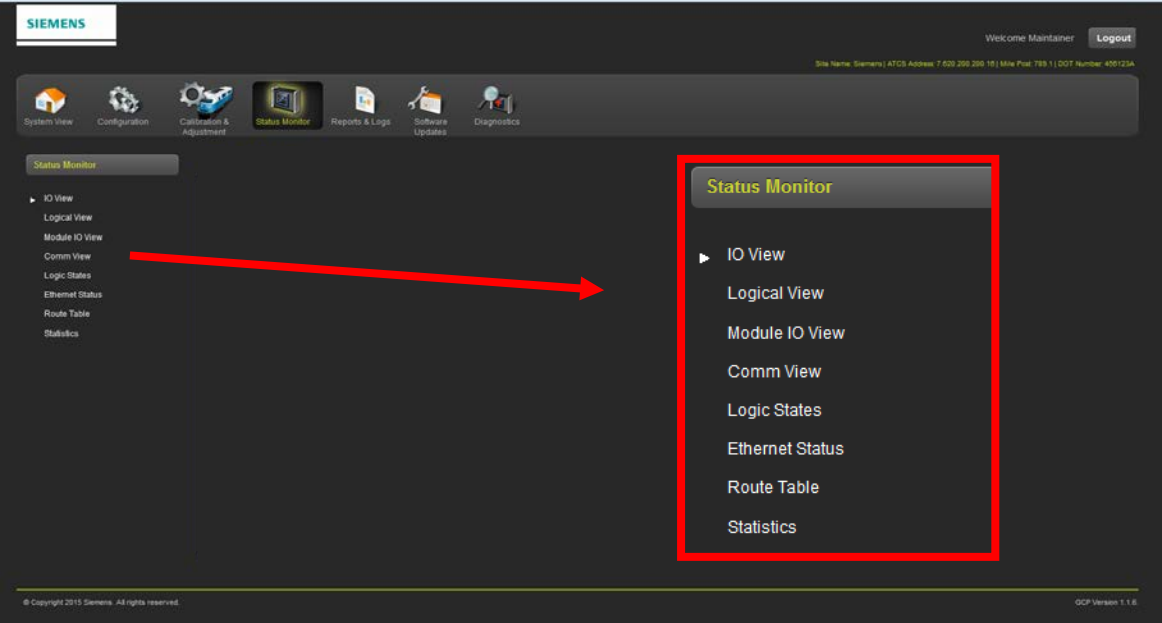

Figure 3-70 CPU III Web UI – Status Monitor Menu

### Vital I/O

The Vital IO View screen provides users with the status of all IO conditions set in the system.

Input		Output	
●	IN 7:2: GD 1.2	●	GC1: Gate Output 1
●	IN 7:3: GD 1.1	●	GC2: Gate Output 2
●	IN 7:5: GP 1.1		

Figure 3-71 CPU III Web UI – Status Monitor Menu – IO View – Vital View

## Logical View

The Logic View screen provides users with the status of all logic conditions set in the system. Click on an arrow [1] of an active logic state and the detail screen appears as shown in Figure 3-73.

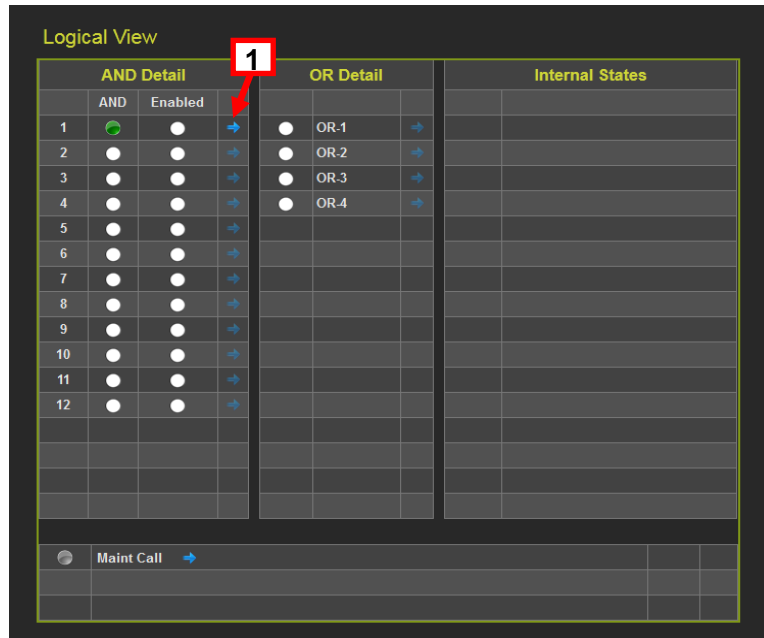

Figure 3-72 CPU III Web UI – Status Monitor Menu – Logical View

## Logic Detail View (GCP5000 Only)

This screen shows the relay view and can be used in troubleshooting to see what is causing a particular output to be deenergized. The Logic Detail View is not supported on the GCP4000.

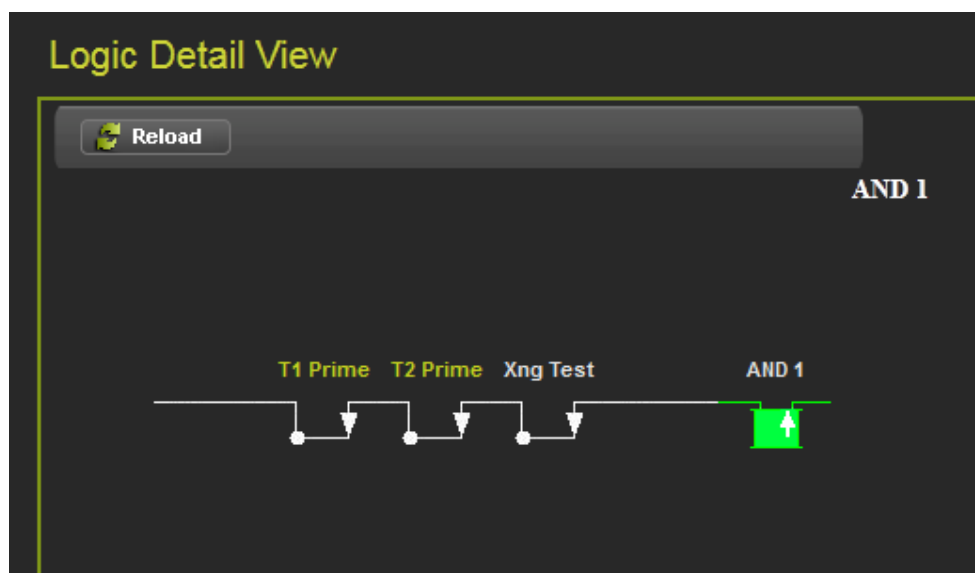

Figure 3-73 CPU III Web UI – Status Monitor Menu – Logical View – Logical View Detail

## Troubleshooting with Logic Detail View

Using the Logic Detail View the user can locate the problem area when system problems occur. In the example in Figure 3-74, the first screen shows that the AND 1 is de-energized, as indicated with the icon being red. Review of the logic indicates T1PrimeA on Track 1 is de-energized. Highlighted text on the logic switch indicates that the user can click on that text and move deeper in the logic and see the detailed circuit for that switch which is shown in the second screen. The second screen shows Track 1 Prime UAX is de-energized (note the text is not highlighted so another level is not available). The Island 1 text is highlighted and another level can be accessed as shown in the third screen. The Island 1 logic is energized and the Island 1 icon is green.

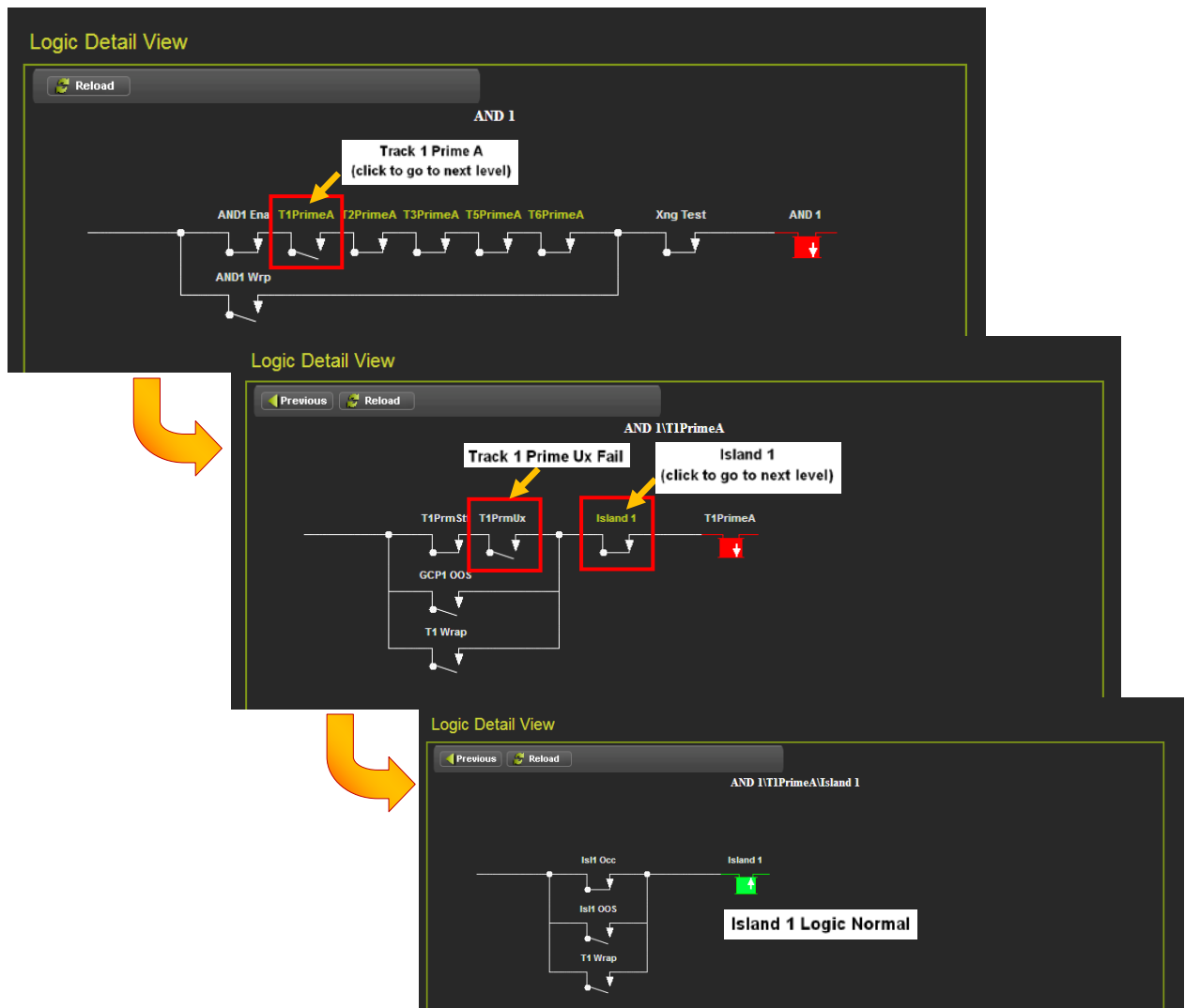

Figure 3-74 Logic View Troubleshooting Example

## Logic View Example with a Timer

Logic switches with an hourglass indicate a timed switch controlled by a user defined timer. Figure 3-75 shows a timed logic switch. The top screen shows the drop delay relay and the bottom screen shows the pick-up relay. The user can view the switch state change when the logic switch times out.

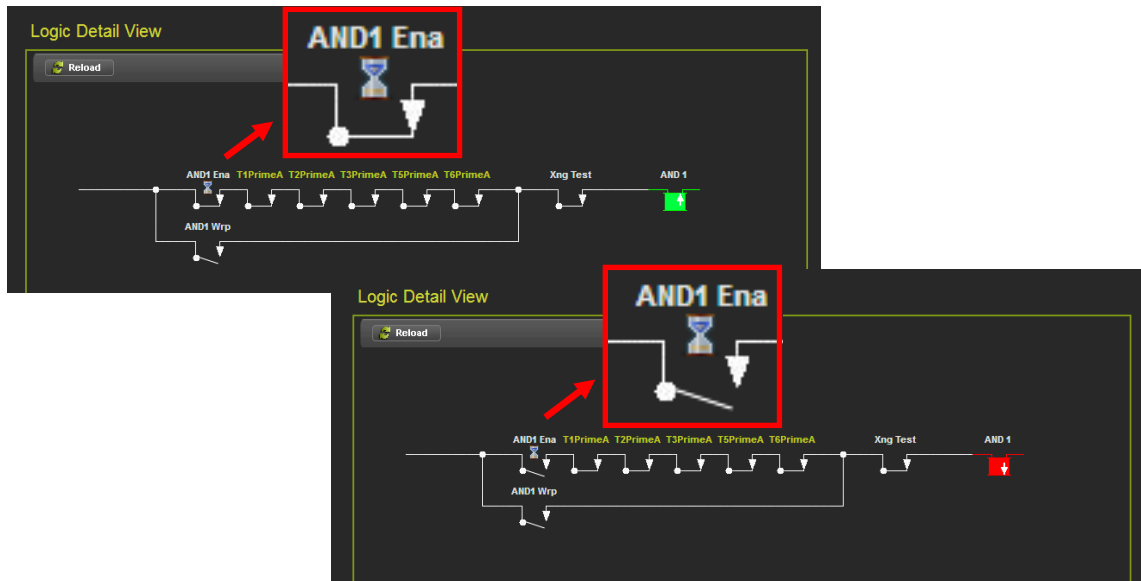

Figure 3-75 Logic View Example with a Timed Logic Switch



## Logic View – Maintenance Call

The user can view the System States on the Logical View screen. In the example shown in Figure 3-76 The Maintenance Call is shown in the System States, clicking on the arrow will bring up the Logic Detail View screen. In this example the SEAR unit indicates a problem.

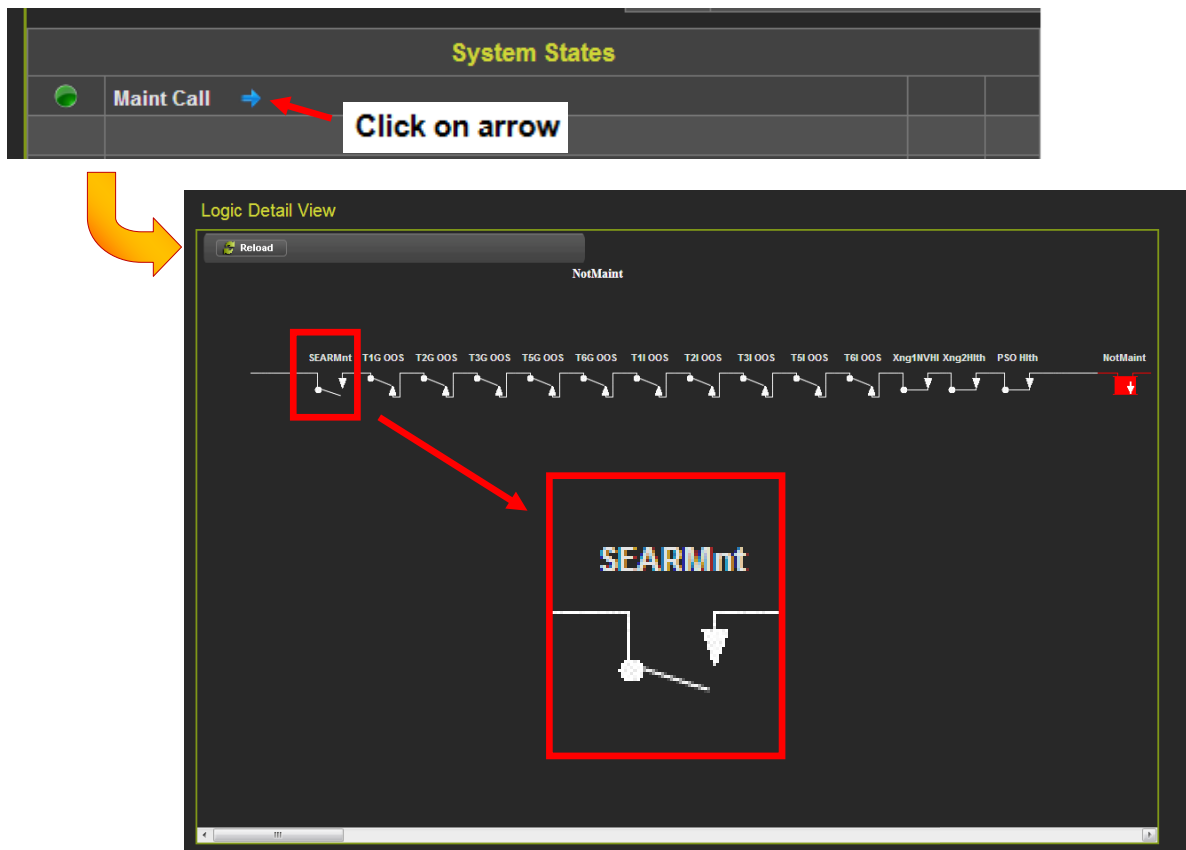

Figure 3-76 System States Logic Detail View

### Module IO View

The Module View displays a graphic of the installed modules and their current status. Red labels indicate a problem or unconfigured module. Green indicates the module is operating properly.

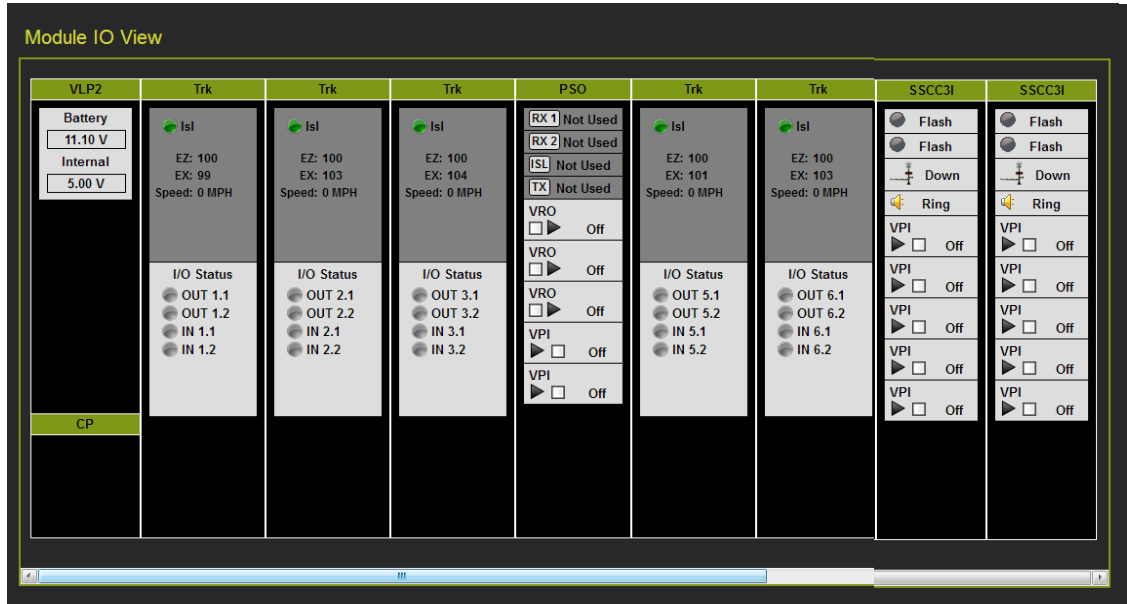

Figure 3-77 CPU III Web UI – Status Monitor – Module IO View

### Comm View

The Comm View displays active communications links. In the example below the link to the SEAR is displayed.

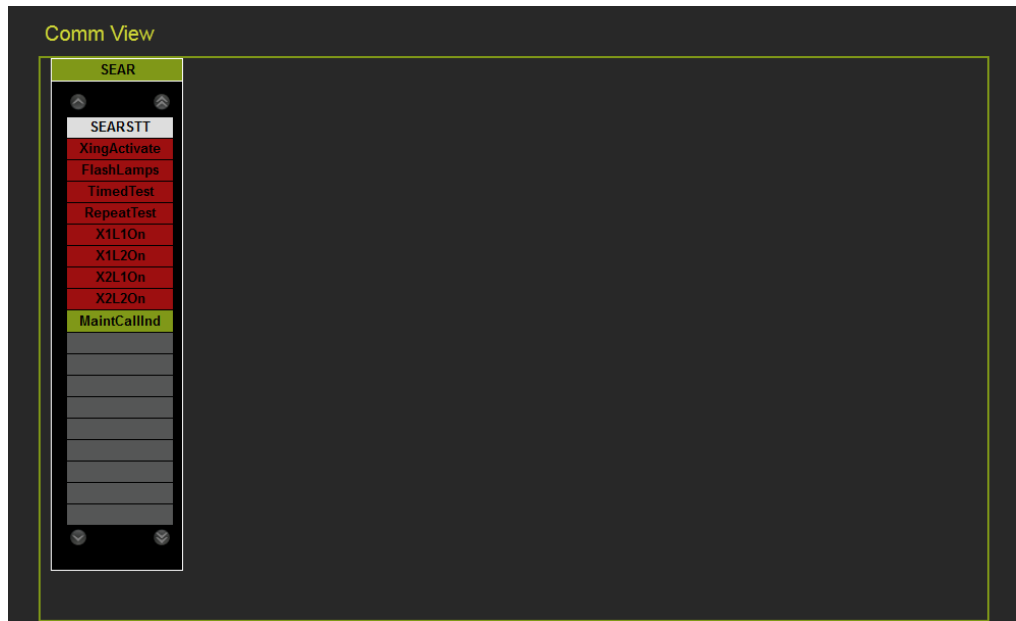
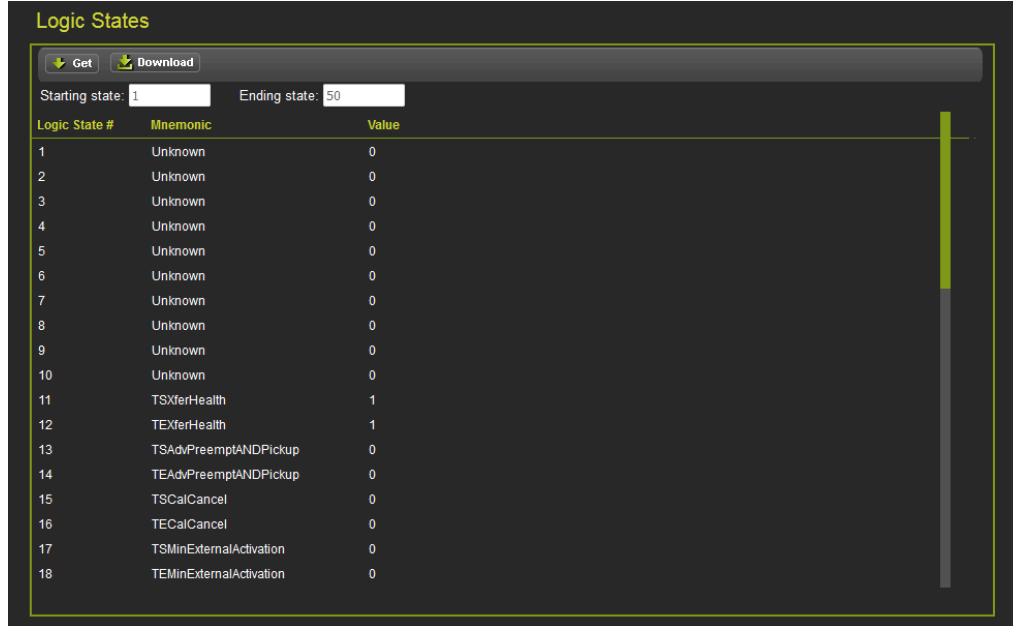

Figure 3-78 CPU III Web UI – Status Monitor Menu – Comm View

## Logic States

The Logic States screen displays the current logic states. The states can be viewed or downloaded into a file. This is for Siemens personnel use only.



Logic States

Get Download

Starting state: 1 Ending state: 50

Logic State #	Mnemonic	Value
1	Unknown	0
2	Unknown	0
3	Unknown	0
4	Unknown	0
5	Unknown	0
6	Unknown	0
7	Unknown	0
8	Unknown	0
9	Unknown	0
10	Unknown	0
11	TSXferHealth	1
12	TEXferHealth	1
13	TSAdvPreemptANDPickup	0
14	TEAdvPreemptANDPickup	0
15	TSCalCancel	0
16	TECalCancel	0
17	TSMInExternalActivation	0
18	TEMinExternalActivation	0

Figure 3-79 CPU III Web UI – Status Monitor Menu – Logic State

## Ethernet Status

The Ethernet Status screen shows the current information of the Ethernet port.

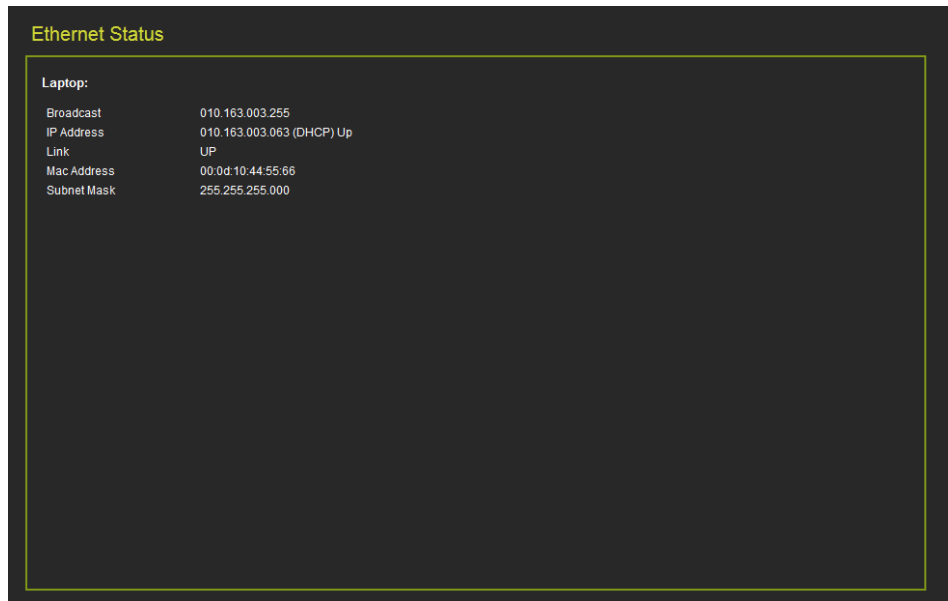

Ethernet Status

Laptop:

Broadcast	010.163.003.255
IP Address	010.163.003.063 (DHCP) Up
Link	UP
Mac Address	00:0d:10:44:55:66
Subnet Mask	255.255.255.000

Figure 3-80 CPU III Web UI – Status Monitor Menu – Ethernet Status

## Route Table

This shows the ATCS address of other devices that the CPU III has established communications.

Port Number	Port Name	ATCS Address	Path	Timeout
1	Local	7.620.100.100.16.01	(none)	Immortal
1	Local	7.620.200.200.16.01	(none)	Immortal
1	Local	7.620.200.200.16.00	(none)	299
2	SEAR2i	7.620.100.100.16.01	Field	Immortal
10	Echelon	7.620.200.200.16.01	Field	Immortal
10	Echelon	7.620.200.200.99.01	Field	297
10	Echelon	7.620.200.200.99.05	Field	197
11	VCPU	7.620.200.200.16.02	Field	Immortal
11	VCPU	7.620.200.200.16.03	Field	290
11	VCPU	7.620.200.200.16.01	Field	Immortal

Figure 3-81 CPU III Web UI – Status Monitor Menu – Route Table Status

These are primarily for Siemens Personnel use. The Vital I/O Module statistics show the communication statistics between the CPU and the I/O modules.

Device	Bad CRC's	Lost Sessions	Reboots
1	0	0	1
2	0	0	1
3	0	1	0
4	0	1	0
5	0	1	0
6	0	1	0
7	0	1	0
8	0	1	0
9	0	1	0
10	0	1	2
11	0	0	1
12	0	1	0
13	0	1	0
14	0	1	0

Figure 3-82 CPU III Web UI – Status Monitor Menu – Statistics

The figures below are examples of the available Statistic screens.

**Statistics**

Type: Vital ATCS

Device	Out Of Order	Stale	Lost Sessions	Vital Msgs Tx	Vital Msgs Rx
1	0	0	0	0	0
2	0	0	0	0	0
3	0	0	0	0	0
4	0	0	0	0	0
5	0	0	0	0	0
6	0	0	0	0	0

**Statistics**

Type: Time

Device	Min	Max	Mean
1	0	1	0
2	1	63	8
3	7	9	8
4	1	2	1
5	0	1	0
6	3	7	4
7	14	77	22

**Statistics**

Type: SIO

SIO Statistics	Value
Bad SIO Packets	7
SIO Tx Packets	65535
SIO Rx Packets	65535
SPI Tx Q Full Count	0
SPI Rx Q Full Count	0

**Statistics**

Type: Echelon

Echelon Statistics	Value
Node Number	1
Tx Count	21920
Rx Count	54089
ACK Fails	0
Neuron Resets	0

Figure 3-83 CPU III Web UI – Status Monitor – Statistics – ATCS Time SIO Echelon®

### 3.1.6 CPU III Web UI – Reports & Logs

The GCP CPU III can generate Event Logs, Diagnostic Logs, Configuration Reports, Version Reports, and VLP/IO Card Logs. All Logs and Reports can be viewed on the screen or can be saved to files for hard copy printing and off-site storage.

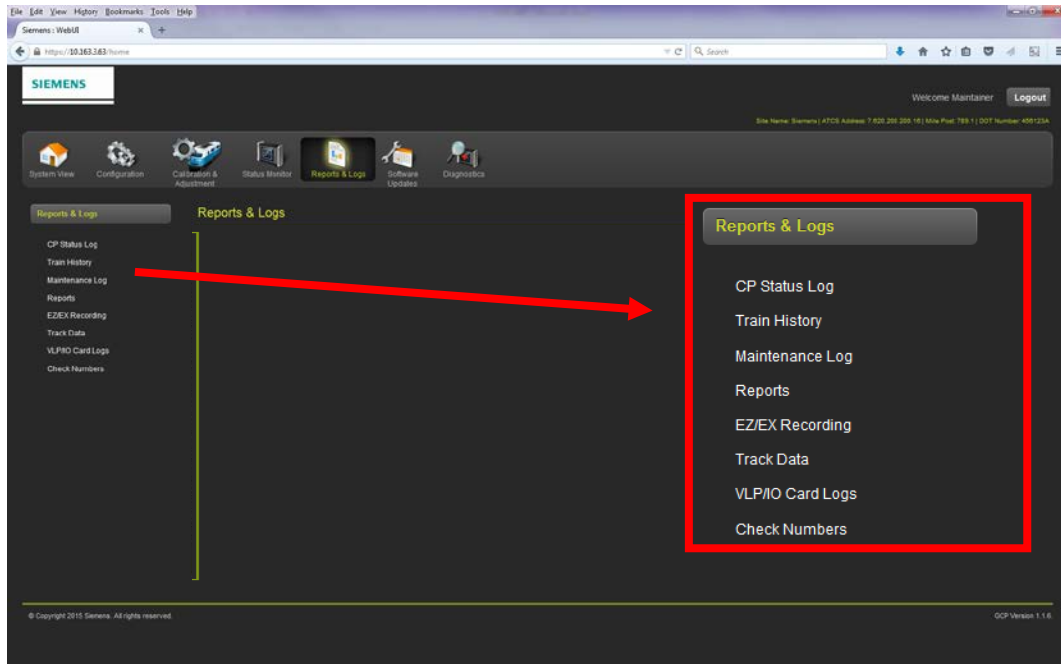

Figure 3-84 CPU III Web UI – Reports and Logs Menu

#### 3.1.6.1 CPU III Web UI – Reports & Logs – Log Options

All logs have the following options to enable the user to obtain the data desired. There are three log options:

- BASIC
- ADVANCED
- TRACE

These options are obtained from the drop menu on the left of the task bar as shown in the figure below.

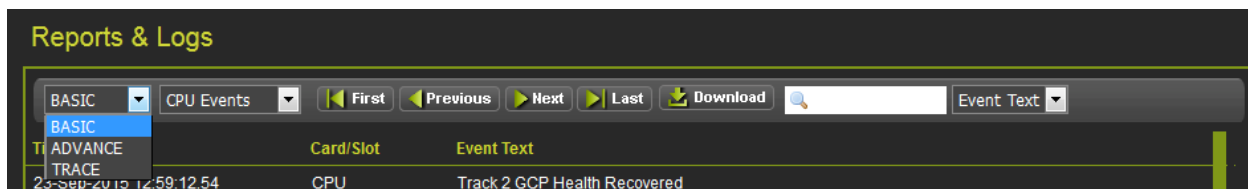
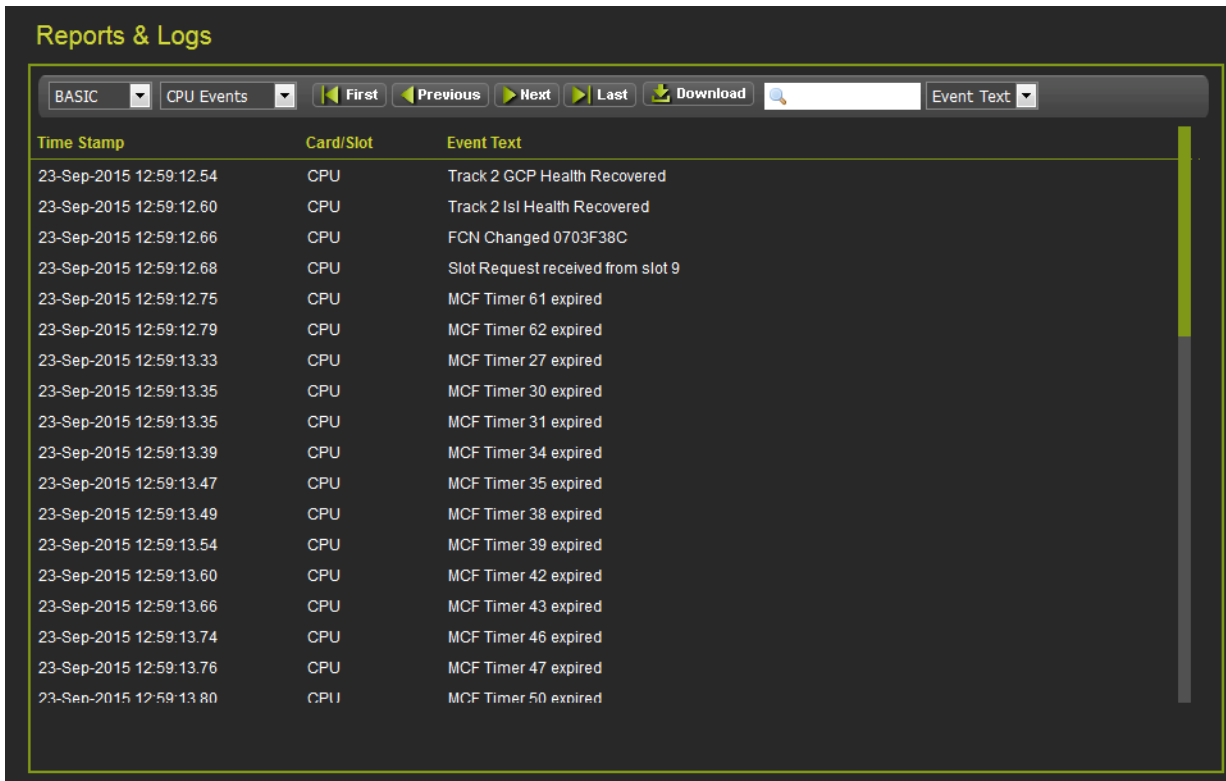

Figure 3-85 CPU III Web UI – Reports and Logs – Log Options

### 3.1.6.2 CPU III Web UI – Reports & Logs – Log Options - Basic

The Basic Option displays the entire log as shown in the figure below.



**Figure 3-86 CPU III Web UI – Reports and Logs – Basic Log**

The Basic Log has a Text Search features, enables searching for specific text strings in the Event Text, Card/Slot or Time Stamp field. Type the text to be found in the text box and press enter. This text search only works on the events in the current view.

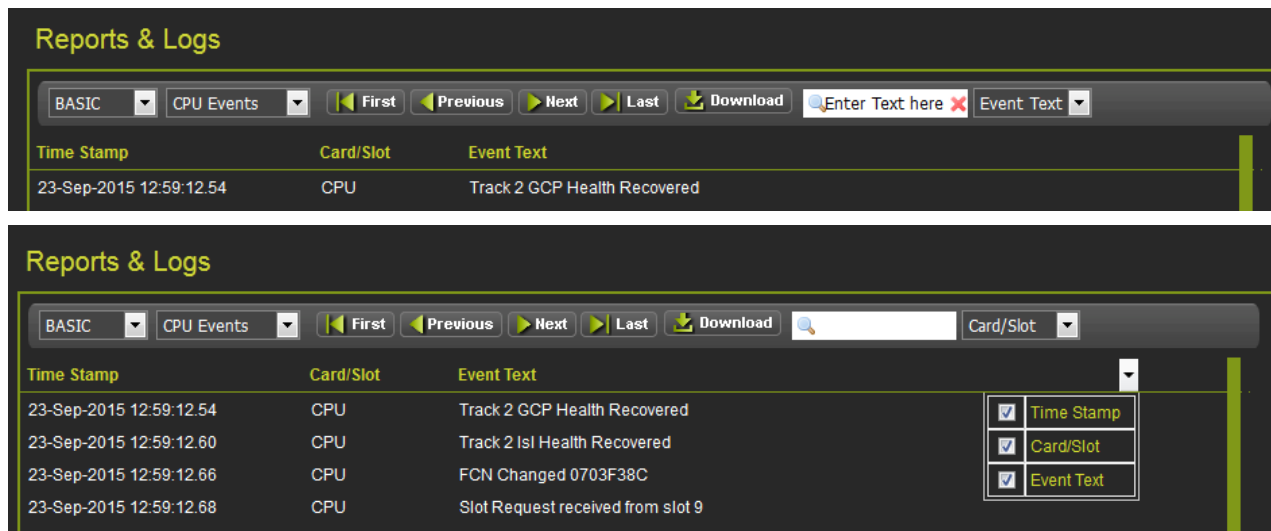

**Figure 3-87 CPU III Web UI – Reports and Logs – Basic Log Search Features**

### 3.1.6.3 CPU III Web UI – Reports & Logs – Log Options - Advanced

When ADVANCE is selected then user can select a portion of the log by time and date. The Set Filter button [1] will open filter options to further refine the log content.

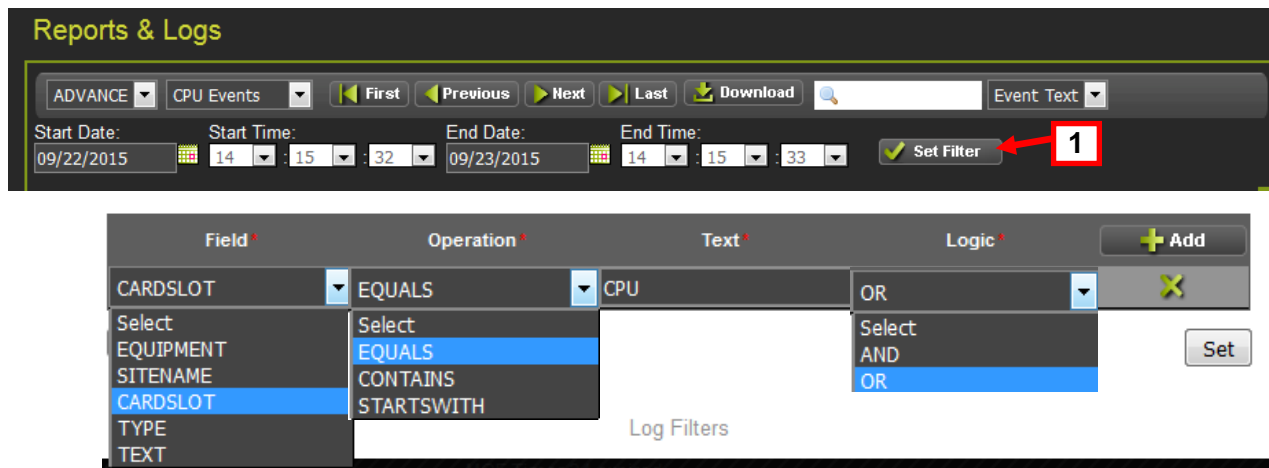

Figure 3-88 CPU III Web UI – Reports and Logs – Advanced Log & Filters

### 3.1.6.4 CPU III Web UI – Reports & Logs – Log Options - Trace

When TRACE is selected the events are recorded in real time, they will be shown in the trace buffer. Use the Clear button to clear the current buffer, and Start and Stop to start and stop Tracing.

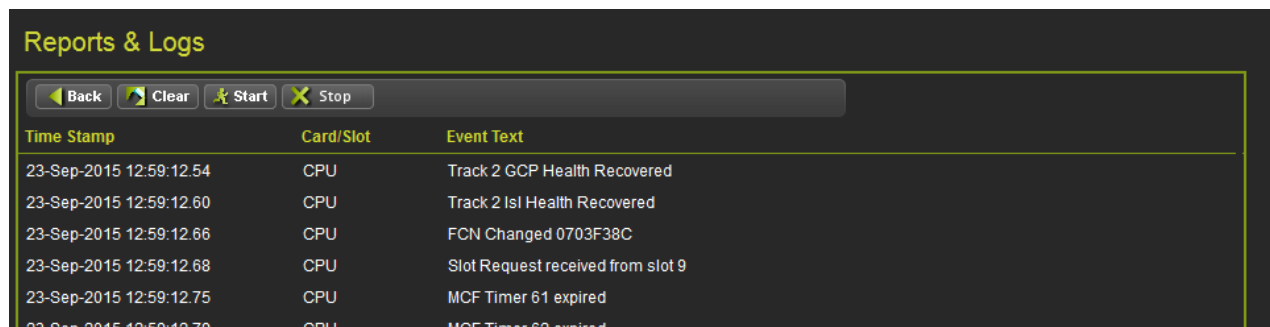

Figure 3-89 CPU III Web UI – Reports and Logs – Trace Log



### 3.1.6.5 CPU III Web UI – Reports & Logs – CP Status Log

The CP Status Log provides a list of events of the CPU activities. A drop menu enables the user to generate logs for CPU Events, Train movements, Maintenance, Train Summary, Non-Vital CPU, or a combination of all the logs.

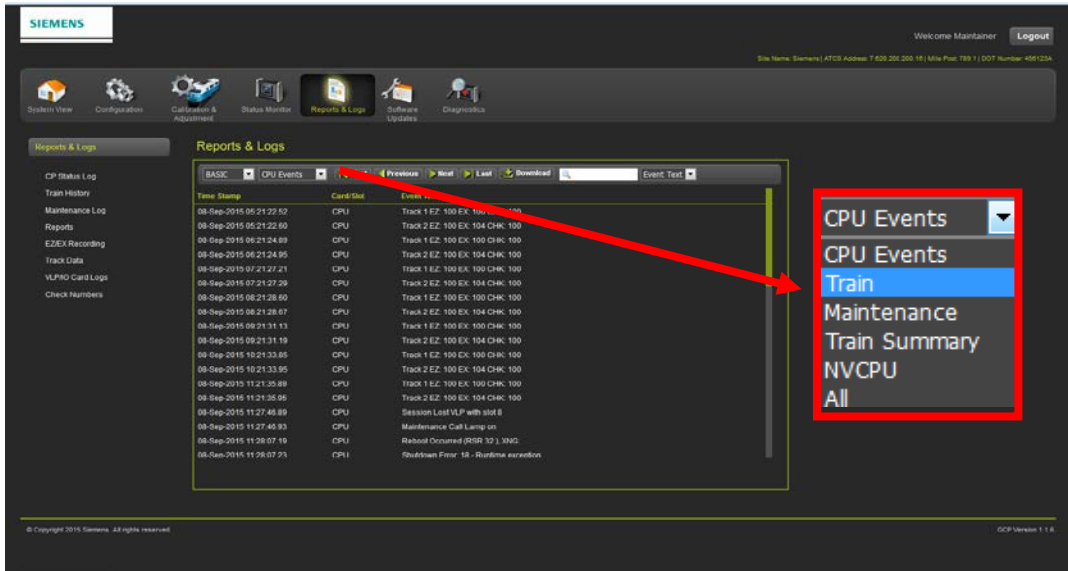

Figure 3-90 CPU III Web UI – Reports and Logs – CP Status Log

### 3.1.6.6 CPU III Web UI – Reports & Logs – CP Status Log - Train Log

The Train Log lists train moves.

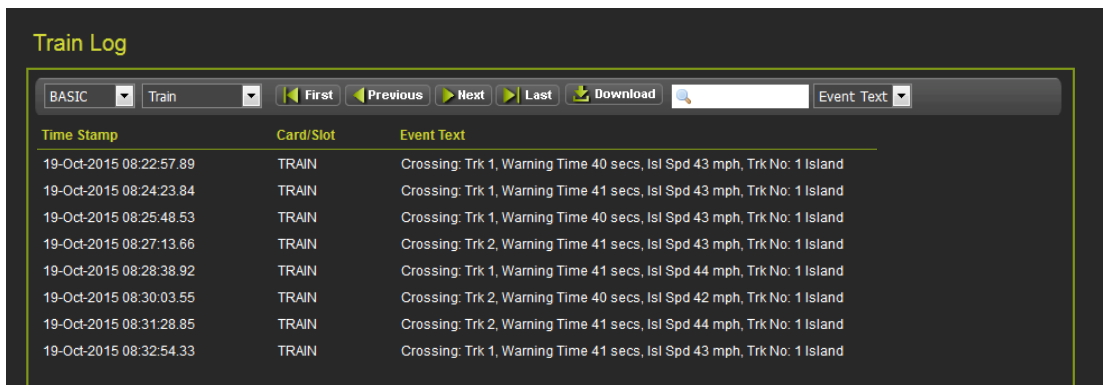

Figure 3-91 CPU III Web UI – Reports and Logs – CP Status Log – Train Log

### 3.1.6.7 CPU III Web UI – Reports & Logs – CP Status Log - Maintenance Log

The Maintenance Log lists activities performed under the Maintenance menu.

Time Stamp	Card/Slot	Event Text
23-Aug-2015 19:09:34.36	MAINT	Configuration update successful.
23-Aug-2015 19:09:50.57	MAINT	Configuration data changed
23-Aug-2015 19:10:08.56	MAINT	Configuration update successful.
23-Aug-2015 19:10:14.75	MAINT	Configuration data changed
23-Aug-2015 19:10:34.89	MAINT	Configuration update successful.
23-Aug-2015 19:23:49.93	MAINT	Configuration data changed
23-Aug-2015 19:24:53.86	MAINT	Configuration update successful.
23-Aug-2015 19:25:05.6	MAINT	Configuration data changed
23-Aug-2015 19:25:18.54	MAINT	Configuration update successful.
23-Aug-2015 19:25:24.76	MAINT	Configuration data changed
23-Aug-2015 19:25:35.75	MAINT	Configuration update successful.
30-Aug-2015 16:24:39.32	MAINT	Configuration data changed
30-Aug-2015 16:25:21.54	MAINT	Configuration update successful.
30-Aug-2015 16:29:13.5	MAINT	Configuration data changed
30-Aug-2015 16:29:21.95	MAINT	Configuration update successful.
30-Aug-2015 16:52:46.72	MAINT	WebUser:Log in MAC Address: A4:BA:DB:02:C0:B1 PORT: LAPTOP
30-Aug-2015 17:29:23.72	MAINT	CCN = 0x1E81EEC8, OCCN = 0x4025798C.
30-Aug-2015 18:16:21.53	MAINT	Configuration data changed

Figure 3-92 CPU III Web UI – Reports and Logs – CP Status Log – Maintenance Log

### 3.1.6.8 CPU III Web UI – Reports & Logs – CP Status Log - Train Summary Log

The Train Summary Log lists a summary of the train moves recorded in the Train Log.

Time Stamp	Card/Slot	Event Text
19-Oct-2015 08:22:57.89	TRAIN	Crossing: Trk 1, Warning Time 40 secs, Isl Spd 43 mph, Trk No: 1 Island
19-Oct-2015 08:24:23.84	TRAIN	Crossing: Trk 1, Warning Time 41 secs, Isl Spd 43 mph, Trk No: 1 Island
19-Oct-2015 08:25:48.53	TRAIN	Crossing: Trk 1, Warning Time 40 secs, Isl Spd 43 mph, Trk No: 1 Island
19-Oct-2015 08:27:13.66	TRAIN	Crossing: Trk 2, Warning Time 41 secs, Isl Spd 43 mph, Trk No: 1 Island
19-Oct-2015 08:28:38.92	TRAIN	Crossing: Trk 1, Warning Time 41 secs, Isl Spd 44 mph, Trk No: 1 Island
19-Oct-2015 08:30:03.55	TRAIN	Crossing: Trk 2, Warning Time 40 secs, Isl Spd 42 mph, Trk No: 1 Island
19-Oct-2015 08:31:28.85	TRAIN	Crossing: Trk 2, Warning Time 41 secs, Isl Spd 44 mph, Trk No: 1 Island
19-Oct-2015 08:32:54.33	TRAIN	Crossing: Trk 1, Warning Time 41 secs, Isl Spd 43 mph, Trk No: 1 Island
19-Oct-2015 08:34:19.55	TRAIN	Crossing: Trk 1, Warning Time 41 secs, Isl Spd 44 mph, Trk No: 1 Island
19-Oct-2015 08:35:45.24	TRAIN	Crossing: Trk 1, Warning Time 41 secs, Isl Spd 44 mph, Trk No: 2 Island
19-Oct-2015 08:37:09.91	TRAIN	Crossing: Trk 2, Warning Time 40 secs, Isl Spd 43 mph, Trk No: 1 Island
19-Oct-2015 08:38:35.15	TRAIN	Crossing: Trk 2, Warning Time 41 secs, Isl Spd 44 mph, Trk No: 1 Island
19-Oct-2015 08:40:00.9	TRAIN	Crossing: Trk 1, Warning Time 41 secs, Isl Spd 44 mph, Trk No: 1 Island
19-Oct-2015 08:41:25.35	TRAIN	Crossing: Trk 1, Warning Time 40 secs, Isl Spd 43 mph, Trk No: 1 Island
19-Oct-2015 08:42:50.46	TRAIN	Crossing: Trk 1, Warning Time 41 secs, Isl Spd 43 mph, Trk No: 1 Island
19-Oct-2015 08:44:15.16	TRAIN	Crossing: Trk 1, Warning Time 40 secs, Isl Spd 43 mph, Trk No: 1 Island
19-Oct-2015 08:45:40.42	TRAIN	Crossing: Trk 2, Warning Time 41 secs, Isl Spd 42 mph, Trk No: 1 Island
19-Oct-2015 08:47:05.75	TRAIN	Crossing: Trk 1, Warning Time 40 secs, Isl Spd 43 mph, Trk No: 1 Island

Figure 3-93 CPU III Web UI – Reports and Logs – CP Status Log – Train Summary Log

### 3.1.6.9 CPU III Web UI – Reports & Logs – CP Status Log - Non-Vital CPU Log

The NV CPU Log lists events specific to the Non-Vital CPU.

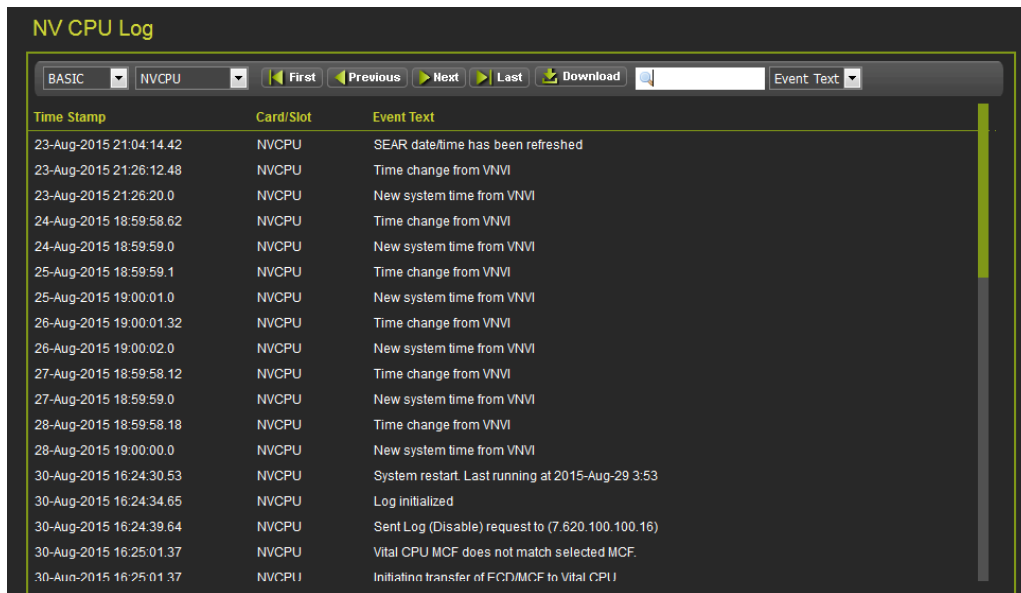

The screenshot shows the 'NV CPU Log' interface. At the top, there is a navigation bar with a dropdown menu set to 'BASIC', another dropdown set to 'NVCPU', and buttons for 'First', 'Previous', 'Next', 'Last', 'Download', and a search field. Below the navigation bar is a table with three columns: 'Time Stamp', 'Card/Slot', and 'Event Text'. The table contains 18 rows of log entries.

Time Stamp	Card/Slot	Event Text
23-Aug-2015 21:04:14.42	NVCPU	SEAR date/time has been refreshed
23-Aug-2015 21:26:12.48	NVCPU	Time change from VNVI
23-Aug-2015 21:26:20.0	NVCPU	New system time from VNVI
24-Aug-2015 18:59:58.62	NVCPU	Time change from VNVI
24-Aug-2015 18:59:59.0	NVCPU	New system time from VNVI
25-Aug-2015 18:59:59.1	NVCPU	Time change from VNVI
25-Aug-2015 19:00:01.0	NVCPU	New system time from VNVI
26-Aug-2015 19:00:01.32	NVCPU	Time change from VNVI
26-Aug-2015 19:00:02.0	NVCPU	New system time from VNVI
27-Aug-2015 18:59:58.12	NVCPU	Time change from VNVI
27-Aug-2015 18:59:59.0	NVCPU	New system time from VNVI
28-Aug-2015 18:59:58.18	NVCPU	Time change from VNVI
28-Aug-2015 19:00:00.0	NVCPU	New system time from VNVI
30-Aug-2015 16:24:30.53	NVCPU	System restart. Last running at 2015-Aug-29 3:53
30-Aug-2015 16:24:34.65	NVCPU	Log initialized
30-Aug-2015 16:24:39.64	NVCPU	Sent Log (Disable) request to (7.620.100.100.16)
30-Aug-2015 16:25:01.37	NVCPU	Vital CPU MCF does not match selected MCF.
30-Aug-2015 16:25:01.37	NVCPU	Initiating transfer of FCD/MCF to Vital CPU

Figure 3-94 CPU III Web UI – Reports and Logs – CP Status Log – Non-Vital CPU Log

### 3.1.6.10 CPU III Web UI – Reports and Logs – Train History

This log lists a history of train moves.

Time Stamp	Card/Slot	Event Text
19-Oct-2015 08:22:57.89	TRAIN	Crossing: Trk 1, Warning Time 40 secs, Isl Spd 43 mph, Trk No: 1 Island
19-Oct-2015 08:24:23.84	TRAIN	Crossing: Trk 1, Warning Time 41 secs, Isl Spd 43 mph, Trk No: 1 Island
19-Oct-2015 08:25:48.53	TRAIN	Crossing: Trk 1, Warning Time 40 secs, Isl Spd 43 mph, Trk No: 1 Island
19-Oct-2015 08:27:13.66	TRAIN	Crossing: Trk 2, Warning Time 41 secs, Isl Spd 43 mph, Trk No: 1 Island
19-Oct-2015 08:28:38.92	TRAIN	Crossing: Trk 1, Warning Time 41 secs, Isl Spd 44 mph, Trk No: 1 Island
19-Oct-2015 08:30:03.55	TRAIN	Crossing: Trk 2, Warning Time 40 secs, Isl Spd 42 mph, Trk No: 1 Island
19-Oct-2015 08:31:28.85	TRAIN	Crossing: Trk 2, Warning Time 41 secs, Isl Spd 44 mph, Trk No: 1 Island
19-Oct-2015 08:32:54.33	TRAIN	Crossing: Trk 1, Warning Time 41 secs, Isl Spd 43 mph, Trk No: 1 Island

Figure 3-95 CPU III Web UI – Reports and Logs – Train History Log

### 3.1.6.11 CPU III Web UI – Reports and Logs – Maintenance Log

The Maintenance Log lists activities performed under the Maintenance menu.

Time Stamp	Card/Slot	Event Text
23-Aug-2015 19:09:34.36	MAINT	Configuration update successful.
23-Aug-2015 19:09:50.57	MAINT	Configuration data changed
23-Aug-2015 19:10:08.56	MAINT	Configuration update successful.
23-Aug-2015 19:10:14.75	MAINT	Configuration data changed
23-Aug-2015 19:10:34.89	MAINT	Configuration update successful.
23-Aug-2015 19:23:49.93	MAINT	Configuration data changed
23-Aug-2015 19:24:53.86	MAINT	Configuration update successful.
23-Aug-2015 19:25:05.6	MAINT	Configuration data changed
23-Aug-2015 19:25:18.54	MAINT	Configuration update successful.
23-Aug-2015 19:25:24.76	MAINT	Configuration data changed
23-Aug-2015 19:25:35.75	MAINT	Configuration update successful.
30-Aug-2015 16:24:39.32	MAINT	Configuration data changed
30-Aug-2015 16:25:21.54	MAINT	Configuration update successful.
30-Aug-2015 16:29:13.5	MAINT	Configuration data changed
30-Aug-2015 16:29:21.95	MAINT	Configuration update successful.
30-Aug-2015 16:52:46.72	MAINT	WebUserLog in MAC Address: A4:BA:DB:02:C0:B1 PORT: LAPTOP
30-Aug-2015 17:29:23.72	MAINT	CCN = 0x1E81EEC8, OCCN = 0x4025798C.
30-Aug-2015 18:16:21.53	MAINT	Configuration data changed

Figure 3-96 CPU III Web UI – Reports and Logs – Maintenance Log

### 3.1.6.12 CPU III Web UI – Reports and Logs – Reports

The Reports menu has five reports:

- Configuration Report
- Program Report
- Minimum Program Steps
- Template Report
- Version Report

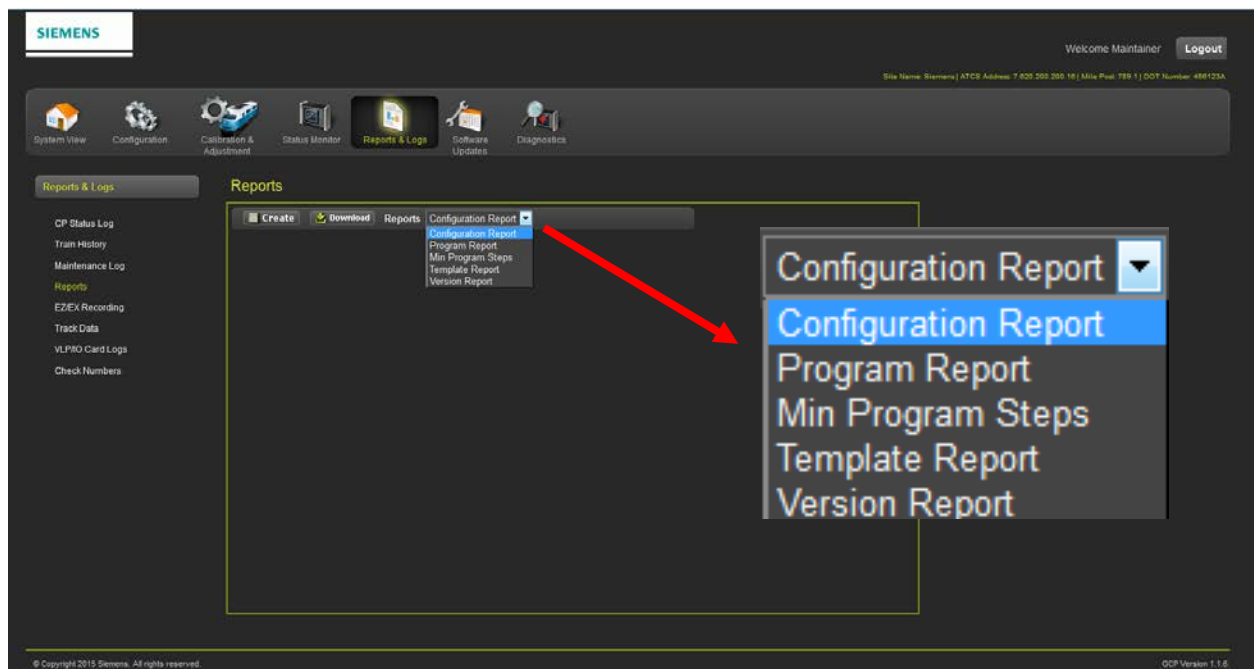
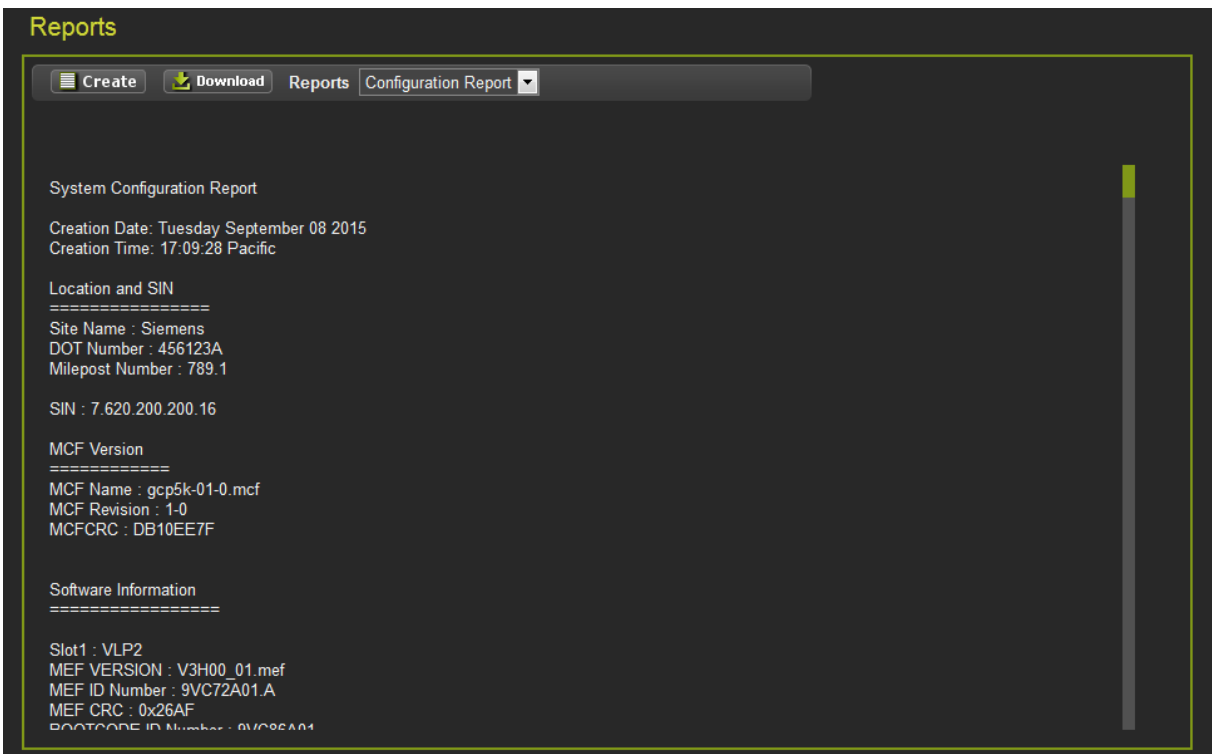

Figure 3-97 CPU III Web UI – Reports and Logs – Reports

### 3.1.6.13 CPU III Web UI – Reports and Logs – Reports – Configuration Report

Click the Create button to display the Configuration Report. The Configuration Report contains all of the configuration data for the system and individual modules. Click the Download button to create a file to export to an external computer or thumb drive. The Configuration report contains all of the information in the other reports, so it is not necessary to download the other reports individually.



**Figure 3-98 CPU III Web UI – Reports and Logs – Reports – Configuration Report**

### 3.1.6.14 CPU III Web UI – Reports and Logs – Reports – Program Report

Click the Create button to display the Program Report. The Program Report contains all of the programming data for the system and individual modules. Click the Download button to create a file to export to an external computer or thumb drive.

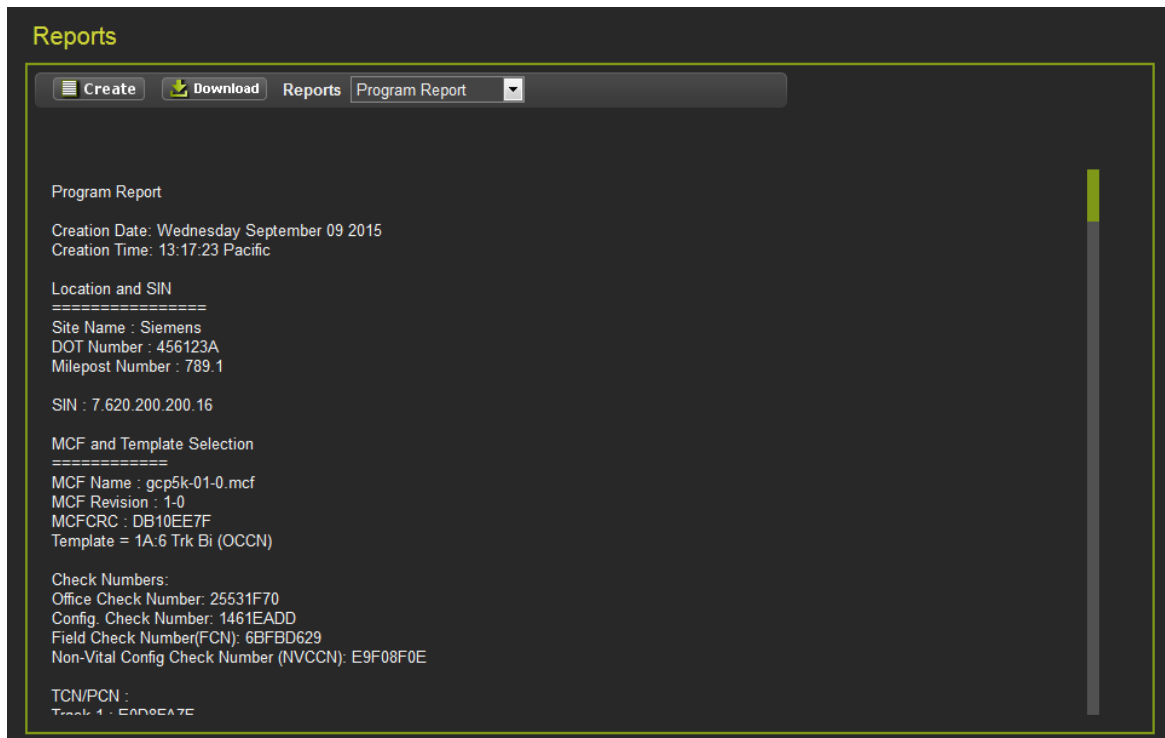

The screenshot shows the 'Reports' section of the CPU III Web UI. At the top, there are buttons for 'Create' and 'Download', followed by a breadcrumb trail: 'Reports > Program Report'. Below this, the 'Program Report' content is displayed in a monospaced font. The report includes the following information:

```

Program Report

Creation Date: Wednesday September 09 2015
Creation Time: 13:17:23 Pacific

Location and SIN
=====
Site Name : Siemens
DOT Number : 456123A
Milepost Number : 789.1

SIN : 7.620.200.200.16

MCF and Template Selection
=====
MCF Name : gcp5k-01-0.mcf
MCF Revision : 1-0
MCFCRC : DB10EE7F
Template = 1A:6 Trk Bi (OCCN)

Check Numbers:
Office Check Number: 25531F70
Config. Check Number: 1461EADD
Field Check Number(FCN): 6BFBD629
Non-Vital Config Check Number (NVCCN): E9F08F0E

TCN/PCN :
Track 1 : E0D9EA7E

```

**Figure 3-99 CPU III Web UI – Reports and Logs – Reports – Program Report**

### 3.1.6.15 CPU III Web UI – Reports & Logs – Reports – Min Program Steps Report

The Minimum Program Steps report is used to simplify field programming.

The minimum program report shows parameters that have changed from their default value. So if a GCP system has to be programmed manually, ensure that the correct MCF is loaded then perform a set to default. Then set all the parameters listed in the Minimum program report. This should result in an OCCN that matches that on the prints.

Note: The OCCN may not match that set on the plans if hidden parameters are not set to their default values. Hidden parameters that are not at default will be shown in the minimum program report with (Hidden) after them. Hidden parameters can be reset to their default values by using the 'reset hidden params' button on the 'Check Numbers' page (see Section 3.1.6.22)

Click the Create button to display the Minimum Program Steps Report. The report contains a capsule of programmed parameters for each individual module. Click the Download button to create a file to export to an external computer or thumb drive.

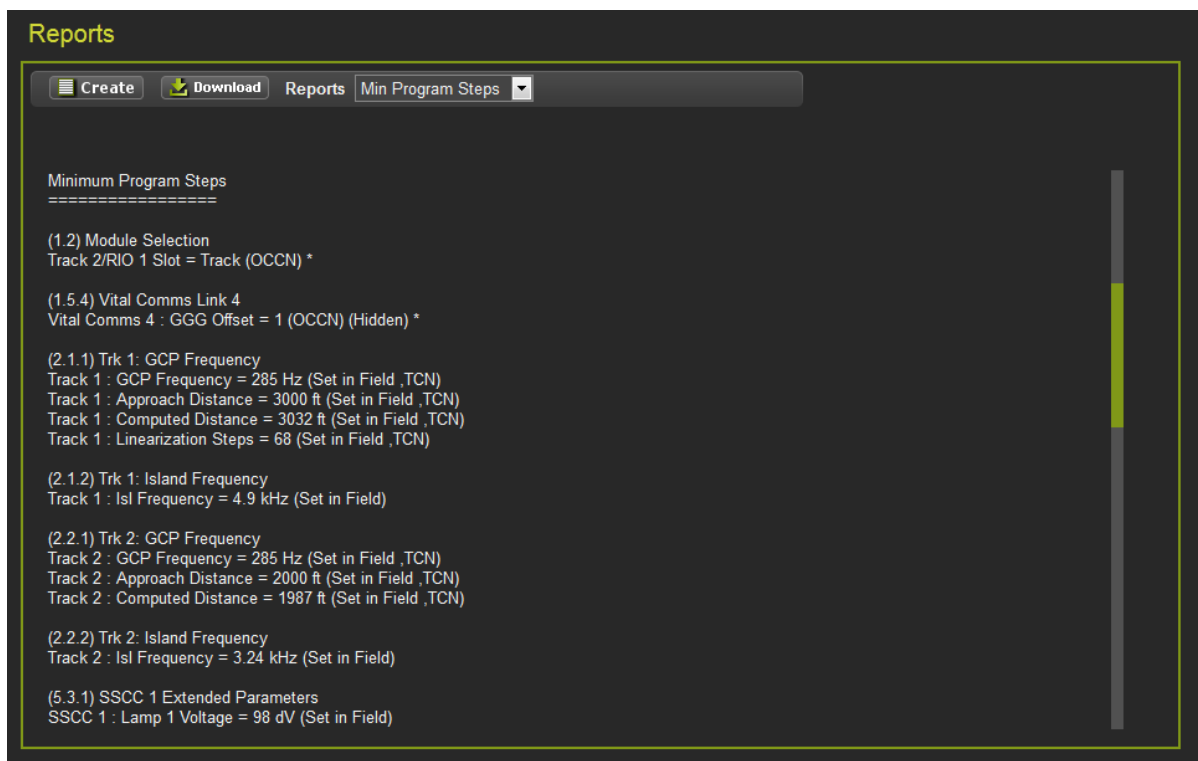

Figure 3-100 CPU III Web UI – Reports and Logs – Reports – Min Program Steps



### 3.1.6.16 CPU III Web UI – Reports & Logs – Reports – Template Report

The Template Report contains the parameter data that shows on the template menus. Click the Create button to display the Report. Click the Download button to create a file to export to an external computer or thumb drive.

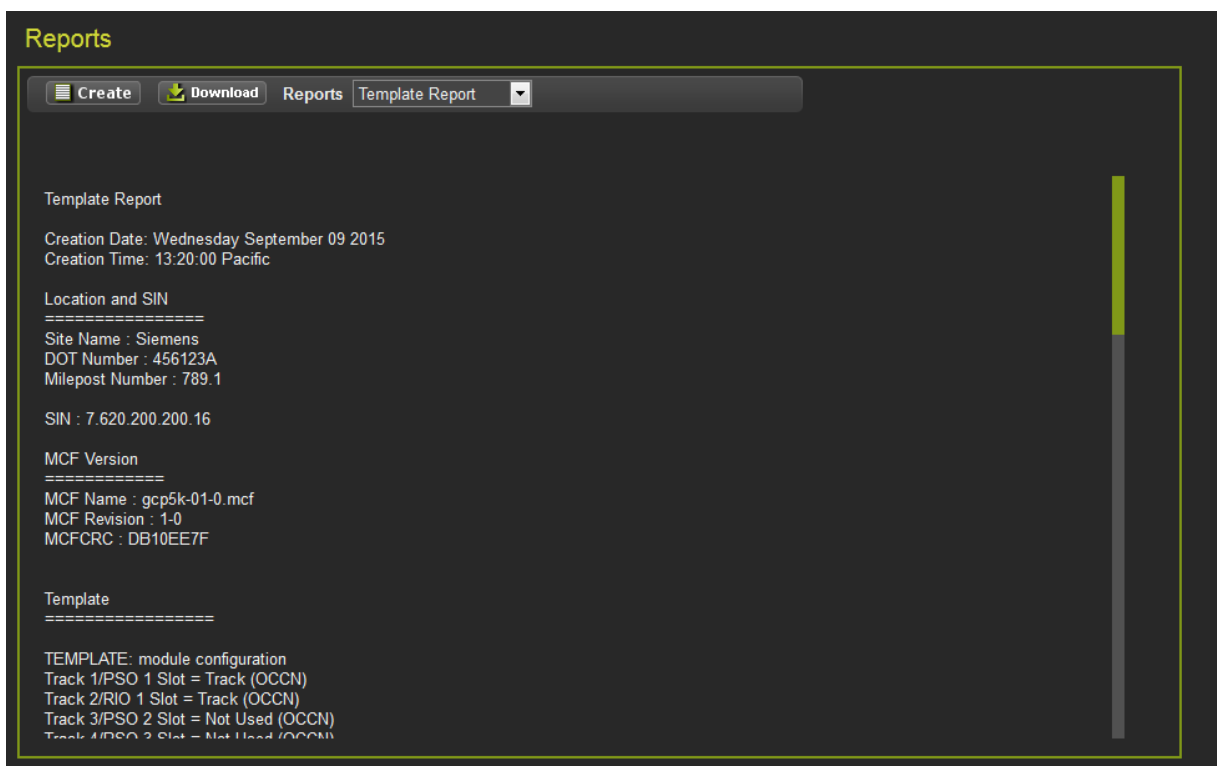

Figure 3-101 CPU III Web UI – Reports and Logs – Reports – Template Report

### 3.1.6.17 CPU III Web UI – Reports & Logs – Reports – Version Report

The Version Report contains the hardware and software versions for each module. Click the Create button to display the Report. Click the Download button to create a file to export to an external computer or thumb drive.

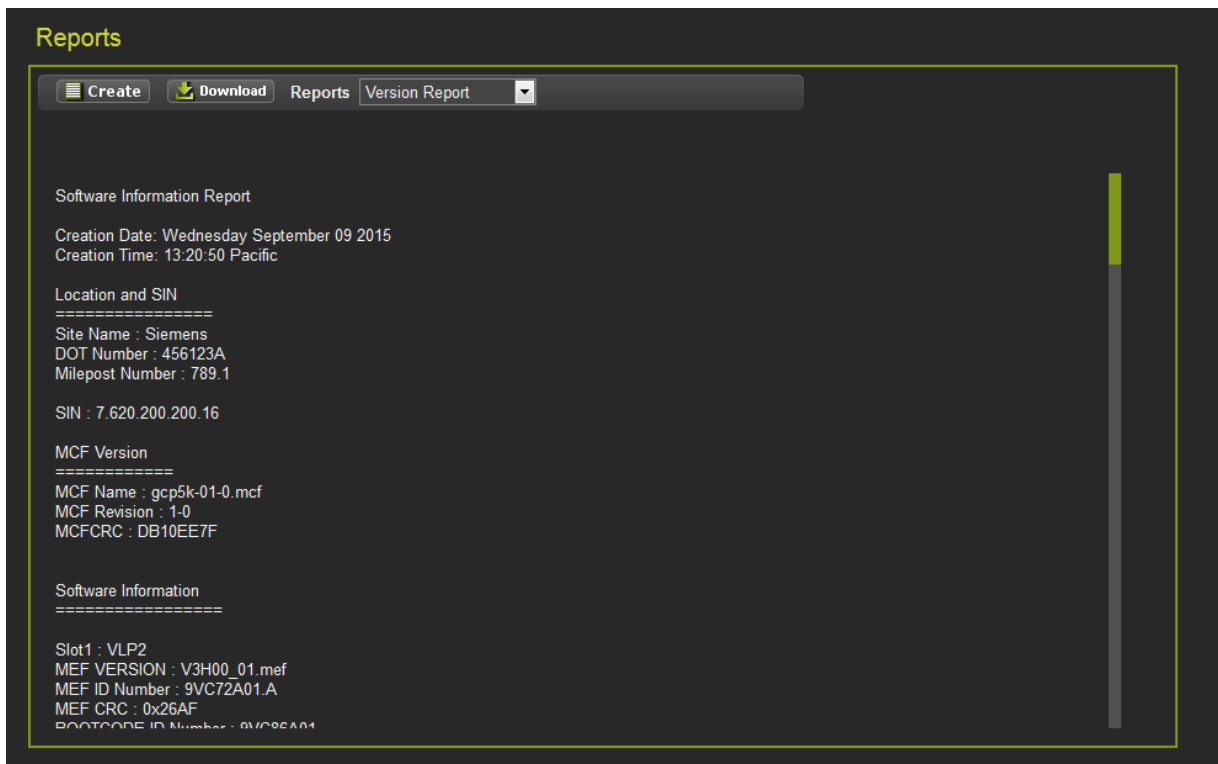

Figure 3-102 CPU III Web UI – Reports and Logs – Reports - Version Report

### 3.1.6.18 CPU III Web UI – Reports & Logs – EZ/EX Recording

The EZ/EX recording feature is used to diagnose track problems. The system records the state of EZ, EX, check EZ and the states of the predictors and island for each track card every second and stores this in a file. A new file is started every day, and the system keeps the last 7 days of files, on day 7 the oldest file is deleted.

The EZ/EX Recording feature enables the user to download a .zip file containing a series of files (one for each 24 hour period) of EZ and EX readings and the related logic states. The .zip file is exported and can be unzipped to review or archive the reports. An example of an EZ/EX Recording download is shown the figures below.

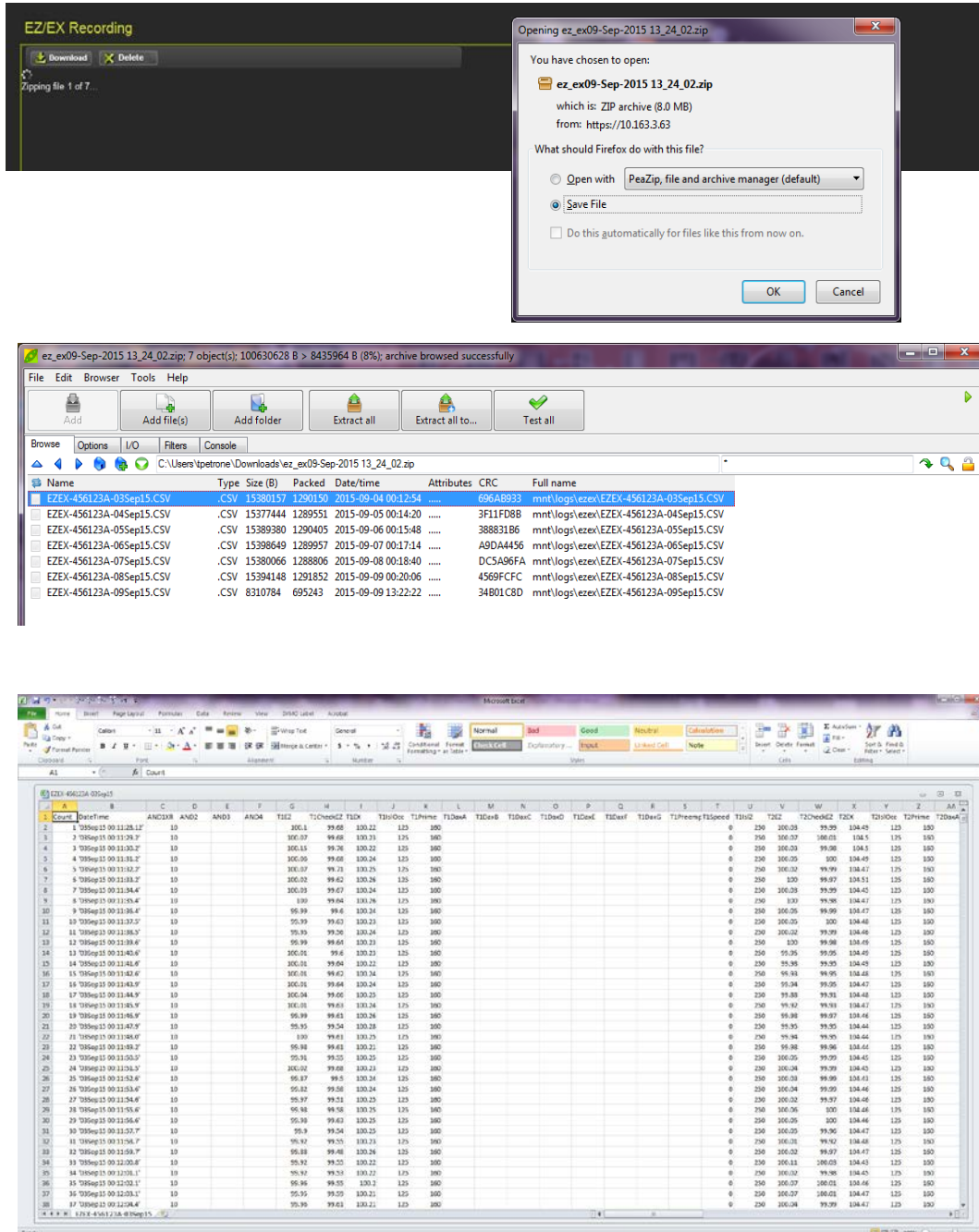

Figure 3-103 CPU III Web UI – Reports and Logs – Reports – EZ/EX Recording

### 3.1.6.19 CPU III Web UI – Reports & Logs – EZ/EX Recording - Using EZ & EX Files

The recorded values are stored in a .csv file that can be reviewed and graphed in Microsoft® Excel®. The values for the discrete states such as Isl T1 occupied, T1 prime, etc. are all given different numeric values so that when the csv is graphed all the states can be seen on one graph. To view .csv files open Microsoft Excel®.

Select File \Open. On the Open window, select 'Text files (\*.prn; \*.txt; \*.csv)' in the "Files of type" field.

	A	B	C	D	E	F	G	H
1	Count	DateTime	T1 Ez	T1 CheckE	T1 Ex	T1 Isl Occ	T1 Prime	AND1 XR
2	0	#####	99	99	93	125	140	155
3	1	#####	99	99	93	125	140	155
4	2	#####	99	99	93	125	140	155
5	3	#####	99	100	93	125	140	155
6	4	#####	100	99	93	125	140	155
7	5	#####	85	91	98	125	140	155
8	6	#####	81	97	99	125	140	155
9	7	#####	93	94	93	125	140	155
10	8	#####	93	92	93	125	140	155
11	9	#####	92	90	93	125	140	155
12	10	#####	90	88	93	125	140	155
13	11	#####	87	85	93	125	140	155

Figure 3-104 CPU III Web UI – Reports & Logs – Reports – EZ/EX Data File Layout

Type of select the file name to be viewed.

Press **Open**.

The file data appears in columns similar to the figure below.

Select a column to graph by clicking on the column header (A through H in the figure above). To select multiple columns, click the first column header then hold down the Ctrl key and click the additional column headers. Columns C, E and G selected in the figure above.

Select **Insert \Chart \ Line Chart**. Select a chart sample and then click **Finish**.

A chart similar to the one below is displayed.

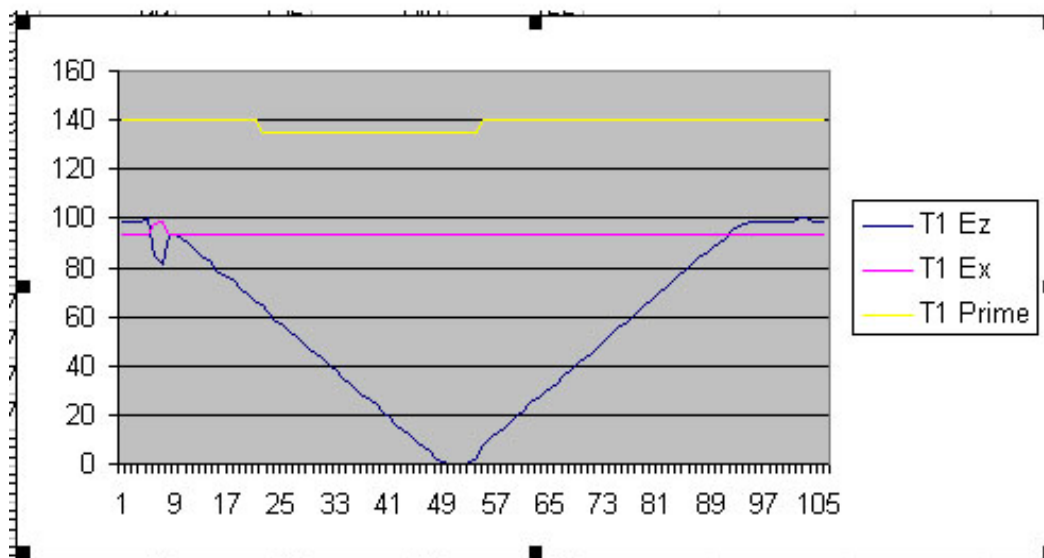

Figure 3-105 CPU III Web UI – Reports & Logs – Reports – Prime, EZ, & EX Chart

### 3.1.6.20 CPU III Web UI – Reports & Logs – Track Data

The Track Data Reports are downloaded in a similar fashion (using .zip files) as the EZ/EX Recording. Click the download button to generate a series of .zip files containing track data. The Track data files are .bin files. An example of the Track Data download is shown in the figure below. This function is available on the GCP5000 only and not applicable to the GCP4000.

**NOTE**

**NOTE**  
Track Data should not be enabled unless requested by Siemens Customer Service for troubleshooting purposes. In the settings screen, only enable one track at once, if multiple tracks are enabled it can cause loss of communication between the CPU and display module.

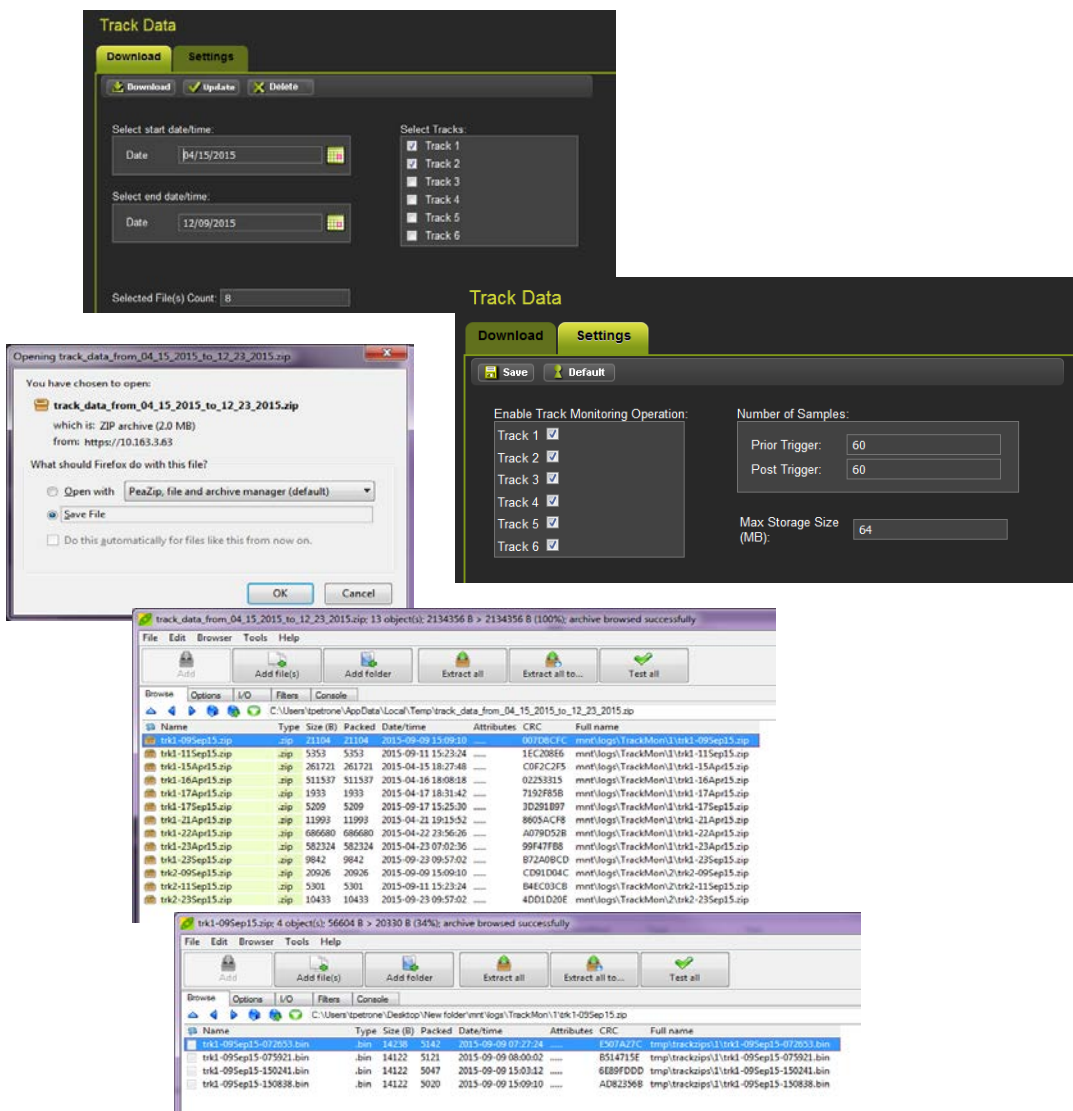

Figure 3-106 CPU III Web UI – Reports and Logs – Reports – Track Data

### 3.1.6.21 CPU III Web UI – Reports & Logs – VLP/IO Card Logs

The VLP and IO card logs are primarily for use by Siemens personnel. The VLP/IO Card Logs screen has three drop-down menus, one for Status or Summary type log, Selection of Module Log, and Selection of Verbosity of the log. A Clear button will clear the selected log. Log navigation buttons are provided for First, Last, Previous, and Next.

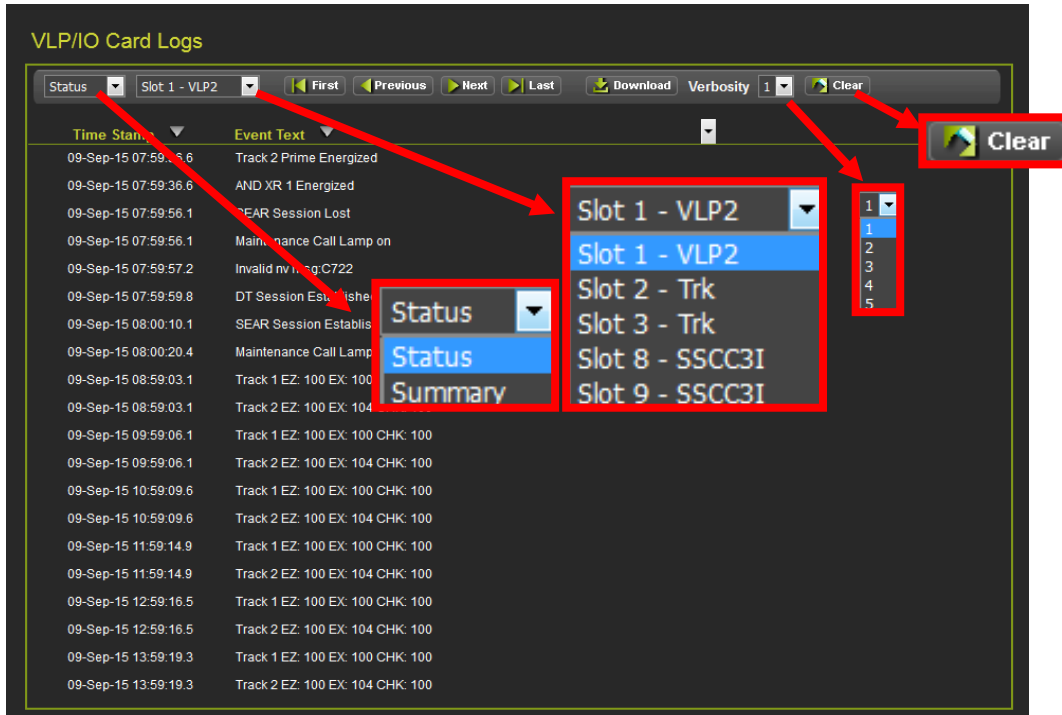



Figure 3-107 CPU III Web UI – Reports and Logs – Reports – VLP/IO Card Logs

### 3.1.6.22 CPU III Web UI – Reports & Logs – Check Numbers

The Check Numbers screen provides a list of the MCF file name and a list of all the CRC numbers used in the system as shown in the figure below.

**NOTE****NOTE**

The OCCN may not match that set on the plans if hidden parameters are not set to their default values. Hidden parameters that are not at default will be shown in the minimum program report with (Hidden) after them. Hidden parameters can be reset to their default values by using the 'Reset Hidden Params' button on the 'Check Numbers' screen.



Check Number	CRC
MCF	DB10EE7F
CCN	1461EADD
OCCN	25531F70
NVCCN	E9F08F0E
FCN	6BFBD629

Figure 3-108 CPU III Web UI – Reports and Logs – Reports – Check Numbers

### 3.1.7 CPU III Web UI – Software Update

Software Updates can be performed using the CPU III. The Software Update Menu has four sub menus. The VLP sub menu has six sub menus.

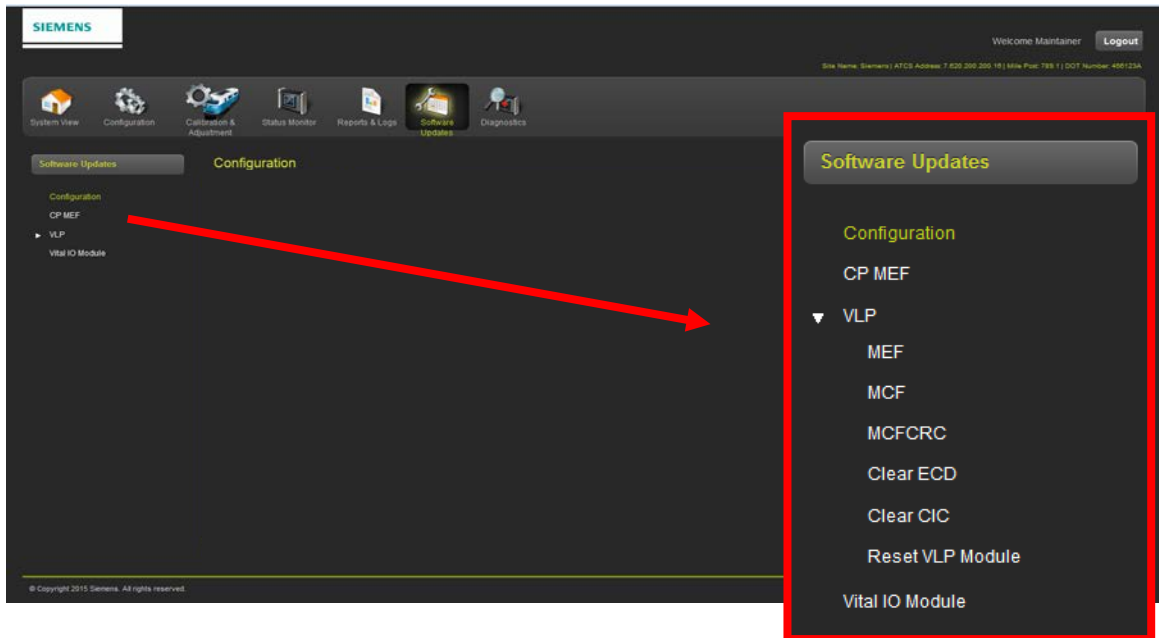

Figure 3-109 CPU III Web UI – Software Updates Menu



### 3.1.7.1 CPU III Web UI – Software Updates – Configuration – Uploading

Loading the configuration file generated by the OCE or DT is the primary way of programming a GCP. The OCE / DT creates a pac (program, package file) with all the parameters set by the office. This can be loaded into the GCP as follows:

To Upload the Configuration unlock the system (see Section 3.1.9 Unlocking Procedure). Perform the following procedure:

After unlocking the system click the Upload button [1], a pop-up window will appear asking to save the current configuration (this is highly recommended) click the OK button [2]. The current configuration file will save in the Downloads file of your browser [3]. Locate the Configuration file to Upload by clicking on the Browse button [4] and locating the file. A pop-up window will appear confirming to upload the selected file, click the OK button [5] to continue. The file will upload, during this time the system will be in the restrictive state.

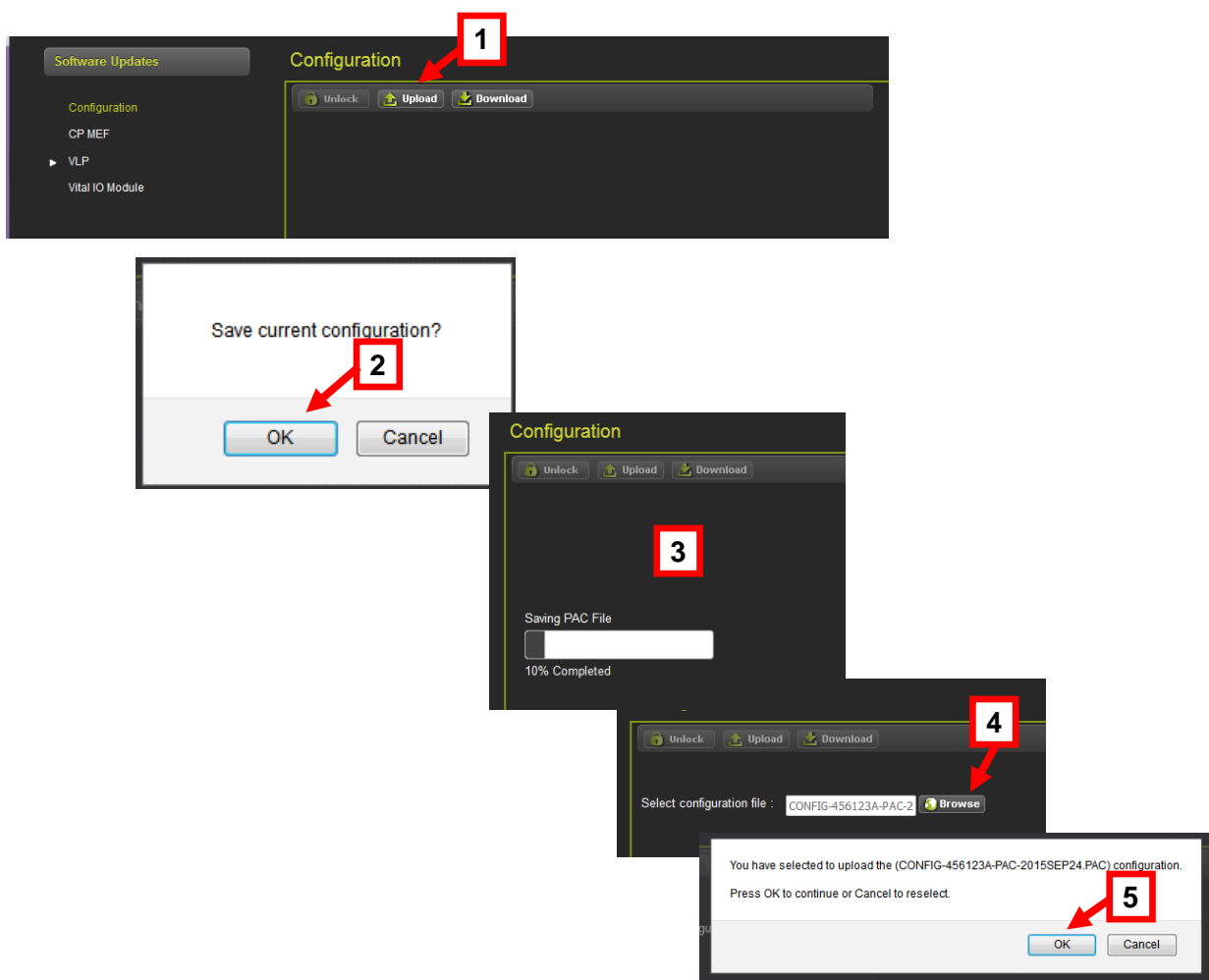

Figure 3-110 CPU III Web UI – Software Updates – Upload Configuration

### 3.1.7.2 CPU III Web UI – Software Updates – Configuration – Downloading

To Download and save the current system configuration click on the Download button and select Save File and click the OK button. The file will save in the Downloads file of your browser.

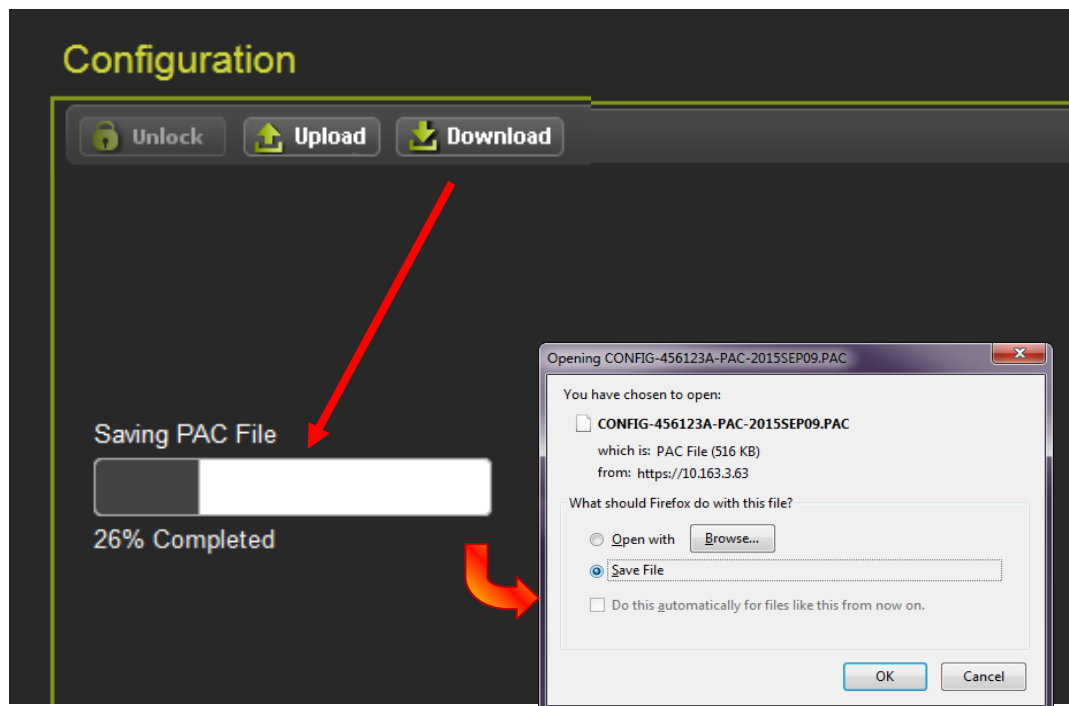

Figure 3-111 CPU III Web UI – Software Updates – Download Configuration PAC File

### 3.1.7.3 CPU III Web UI – Software Updates – CP MEF

To Update the CP MEF click on the CP MEF menu and unlock the system (see Section 3.1.9). Click the Browse button and select the MEF file to upload and click the Update button. The CP MEF will have a name like gcpNcp3\_mef\_x.x.xr.tgz, where x.x.x is the version number.

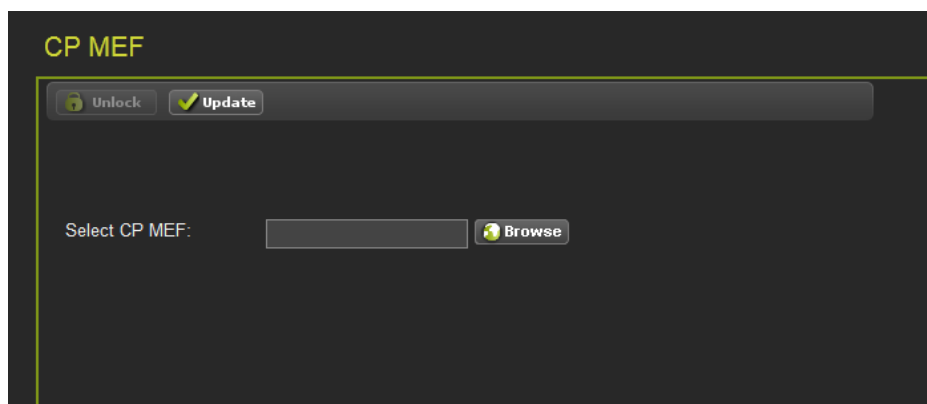

Figure 3-112 CPU III Web UI – Software Updates – Update CP MEF

### 3.1.7.4 CPU III Web UI – Software Updates – VLP - MEF

To Update the VLP MEF click on the VLP menu then click MEF. Unlock the system (see Section 3.1.9). Click the Browse button and select the MEF file to upload and click the Update button.

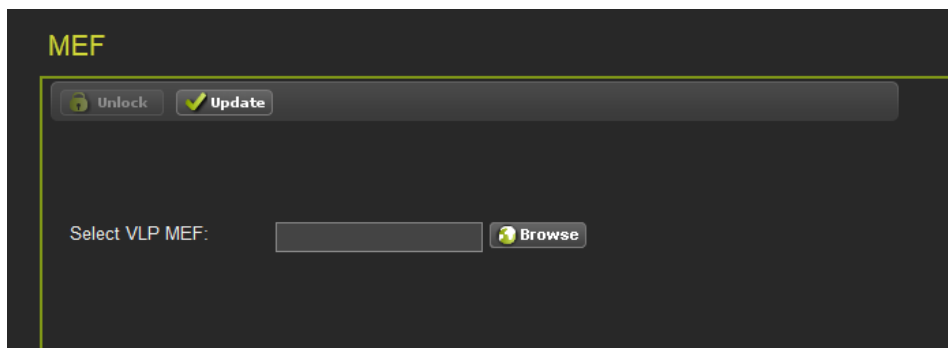

Figure 3-113 CPU III Web UI – Software Updates – Update MEF

### 3.1.7.5 CPU III Web UI – Software Updates – VLP - MCF

To Update the VLP MCF click on the VLP menu then click MCF. Unlock the system (see Section 3.1.9). Click the Browse button and select the MCF file to upload, enter the MCFCRC value and click the Update button. The VLP MCF will have a name like 9VC72-V3Hxx\_xx.mef, where xx\_xx is the version number.

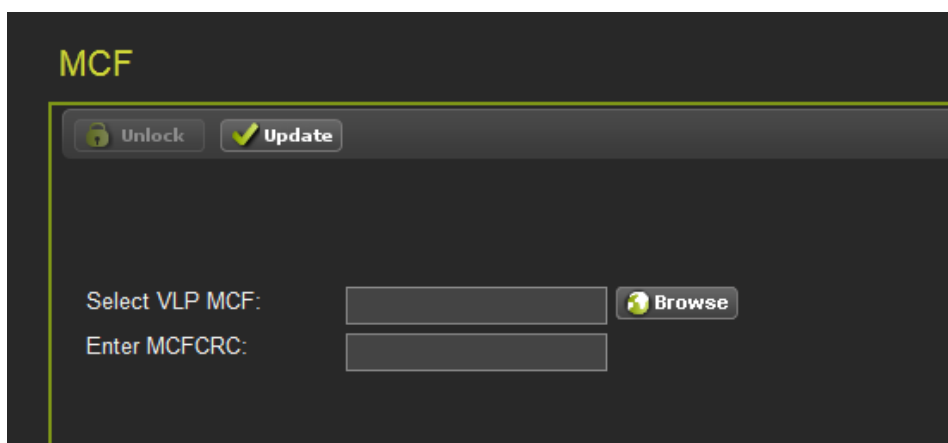

Figure 3-114 CPU III Web UI – Software Updates – Update MCF

### 3.1.7.6 CPU III Web UI – Software Updates – VLP - MCFCRC

To Update the VLP MCFCRC value click on the VLP menu then click MCFCRC. Unlock the system (see Section 3.1.9). Enter the MCFCRC value and click the Update button.

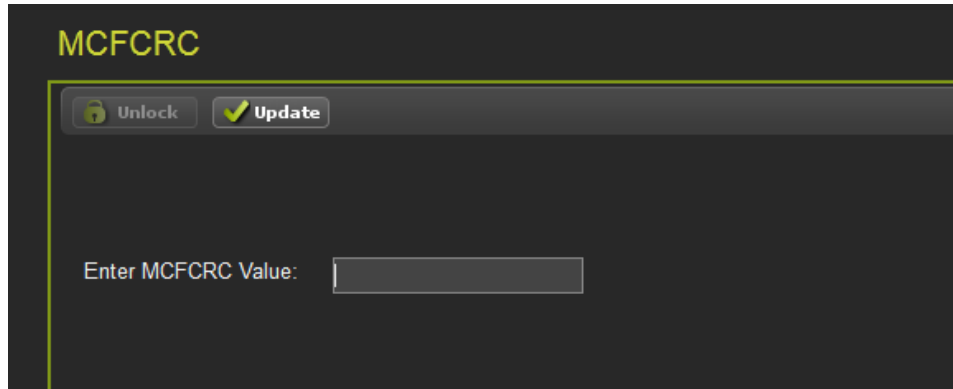

Figure 3-115 CPU III Web UI – Software Updates – Update MFCRC Value

### 3.1.7.7 CPU III Web UI – Software Updates – VLP – Clear ECD



#### WARNING

CLEARING THE ECD WILL REMOVE ALL DATA STORED ON THE ECD FOR BOOT UP OF THE SYSTEM. CLEARED DATA CANNOT BE RECOVERED.

To Clear the ECD click on the VLP menu then click Clear ECD. Unlock the system (see Section 3.1.9). Click on the Clear button. All of the contents in the ECD will be erased.

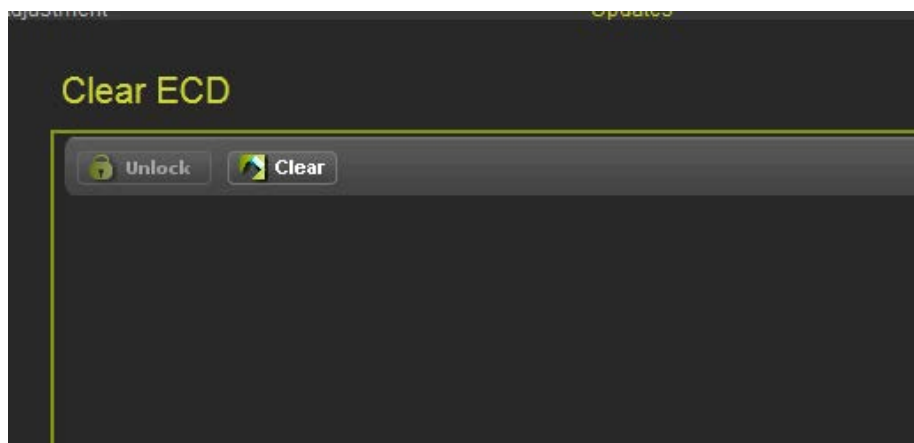

Figure 3-116 CPU III Web UI – Software Updates – Clear ECD

### 3.1.7.8 CPU III Web UI – Software Updates – VLP – Clear CIC



**WARNING**

#### **WARNING**

**CLEARING THE CIC WILL REMOVE ALL DATA STORED ON THE ECD FOR BOOT UP OF THE SYSTEM. CLEARED DATA CANNOT BE RECOVERED.**

To Clear the CIC click on the VLP menu then click Clear CIC. Unlock the system (see Section 3.1.9). Click on the Clear button. All of the contents in the CIC will be erased.

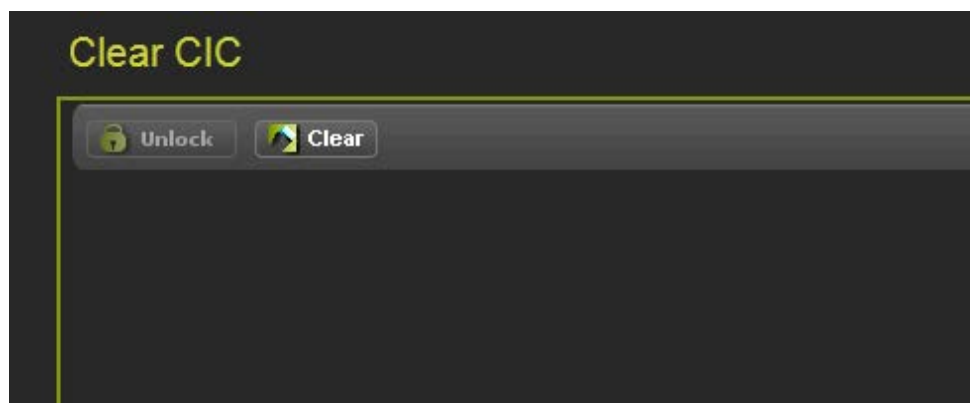

**Figure 3-117 CPU III Web UI – Software Updates – Clear CIC**

### 3.1.7.9 CPU III Web UI – Software Updates – VLP – Reset VLP

After unlocking the system, most procedures will include resetting the VLP module to restore system operation. In the event a procedure is cancelled or does not include resetting of the VLP module, it will be necessary to manually reset the VLP module to restore the system from the restrictive state to normal operation. Use the following procedure to rest the VLP Module:

To manually reset the VLP Module navigate to the Software Updates [1] menu. From the Software Updates menu expand the VLP Menu [2] and select the Reset VLP Module Menu [3]. Click on the Reset VLP button [4], a pop-up screen [5] will appear to verify the CPU is to be rebooted. A confirmation screen [6] will appear confirming the CPU has been rebooted.

Verify no alarms are present (no Diagnostic icons on the screen) and the system is operating properly.

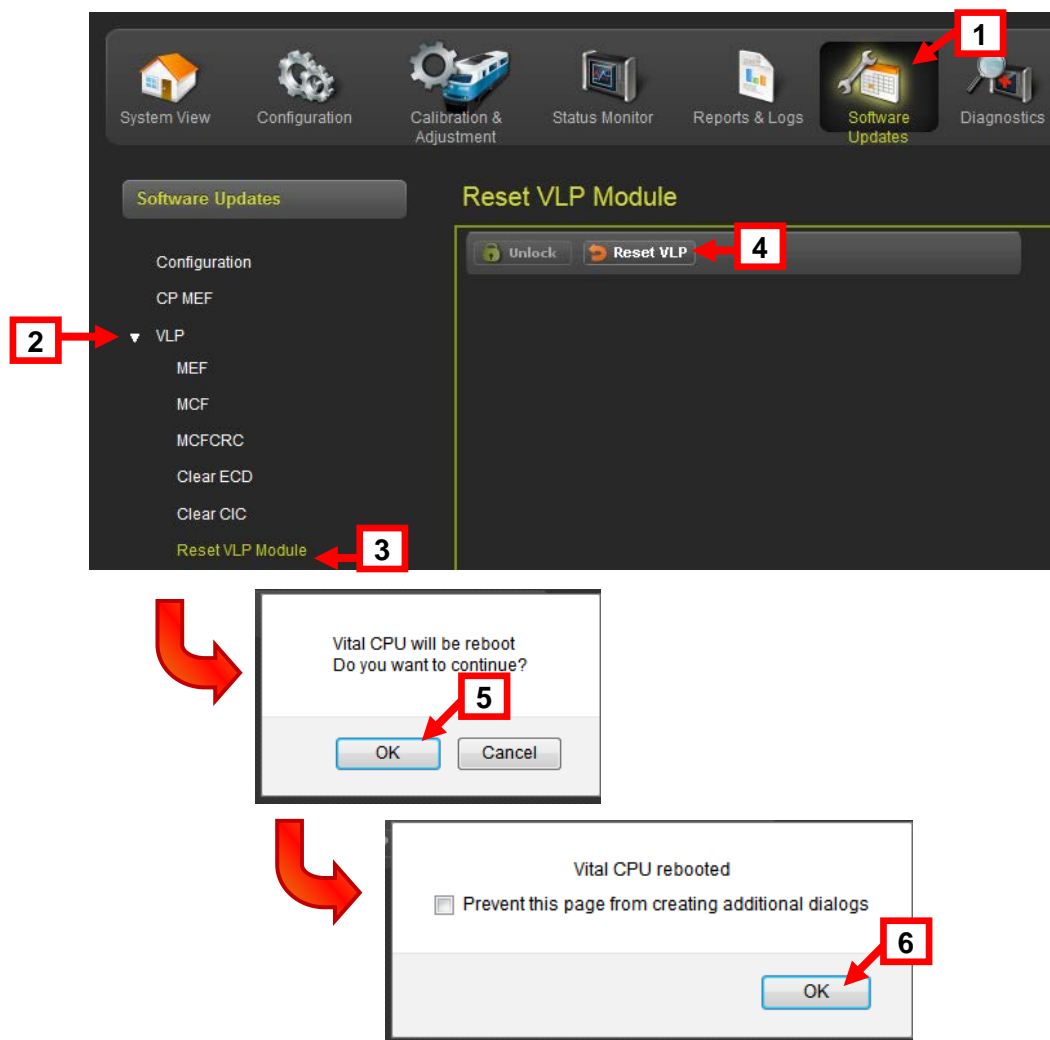

Figure 3-118 CPU III Web UI – Software Updates – Reset VLP

### 3.1.7.10 CPU III Web UI – Software Updates – Vital IO Module

To install software into the Vital IO Modules follow the following procedure:

Click on the Vital IO Module Menu and click on the Install Software button as shown below.

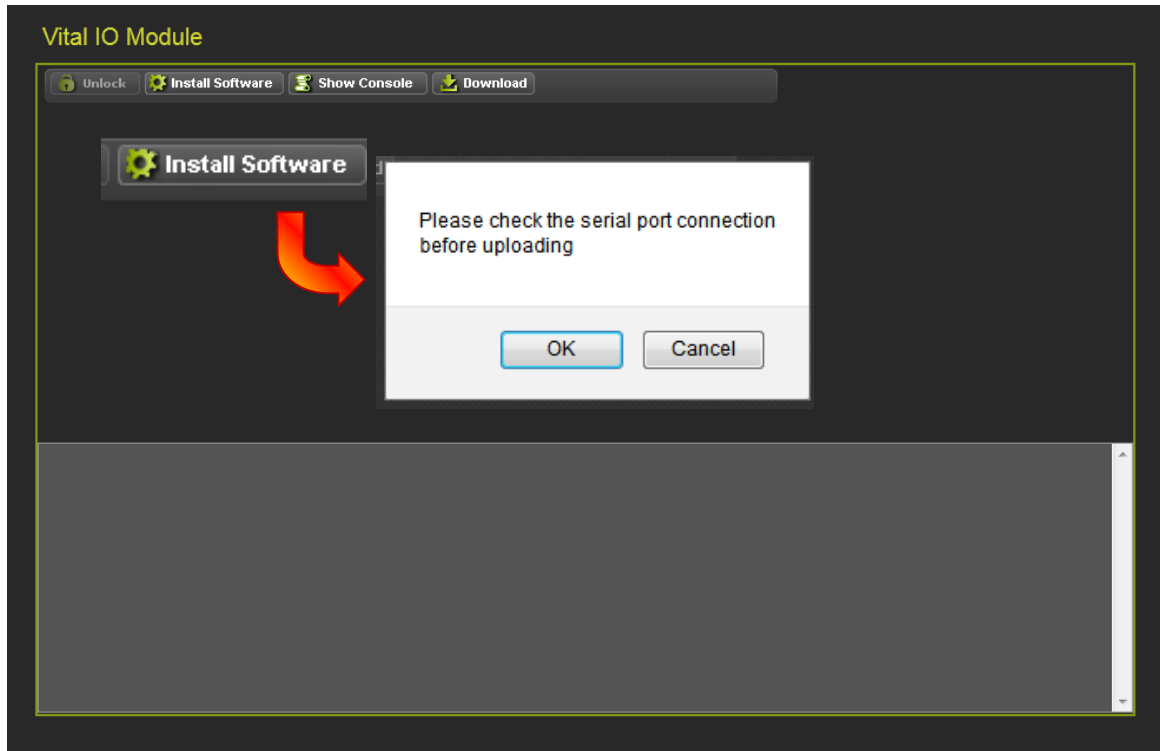
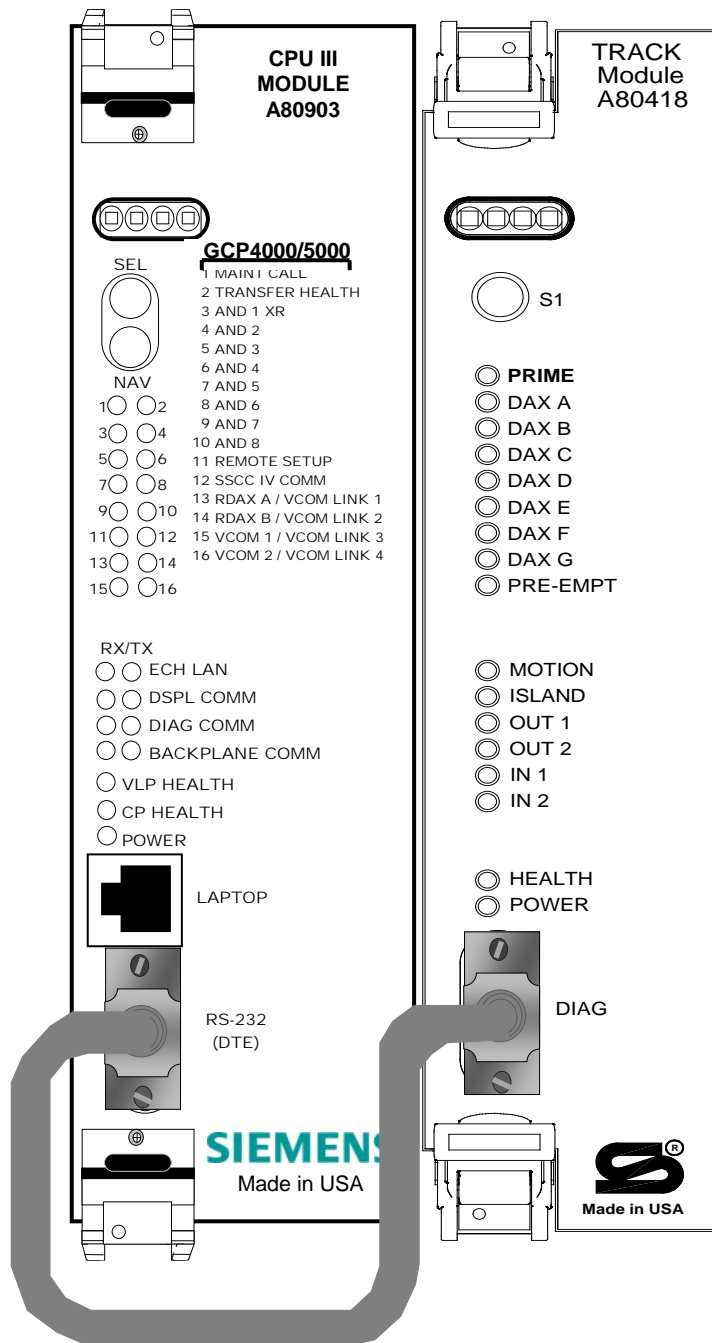

Figure 3-119 CPU III Web UI – Software Updates – Vital IO Module Install Software

For Module software updates, connect a serial cable (DB-9 Male-DB-9 Female) from the CPU III DTE port to the Diag port of the Module receiving the software update as shown in the figure below.



**Figure 3-120 Serial Cable Connection for Module Software Updates**



### 3.1.7.11 CPU III Web UI – Software Updates – Vital IO – Download Console Log

To download the Vital IO Module Console Log click on the Download button. The user has the option to open the text file and view or can save the file.

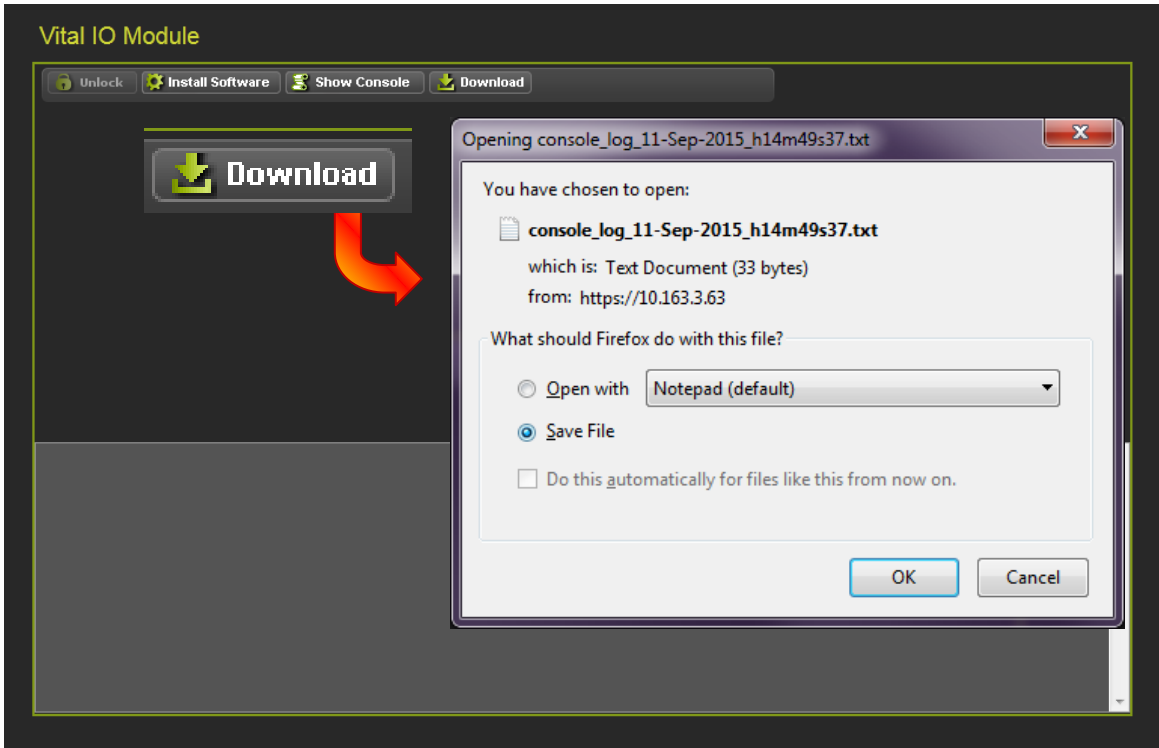
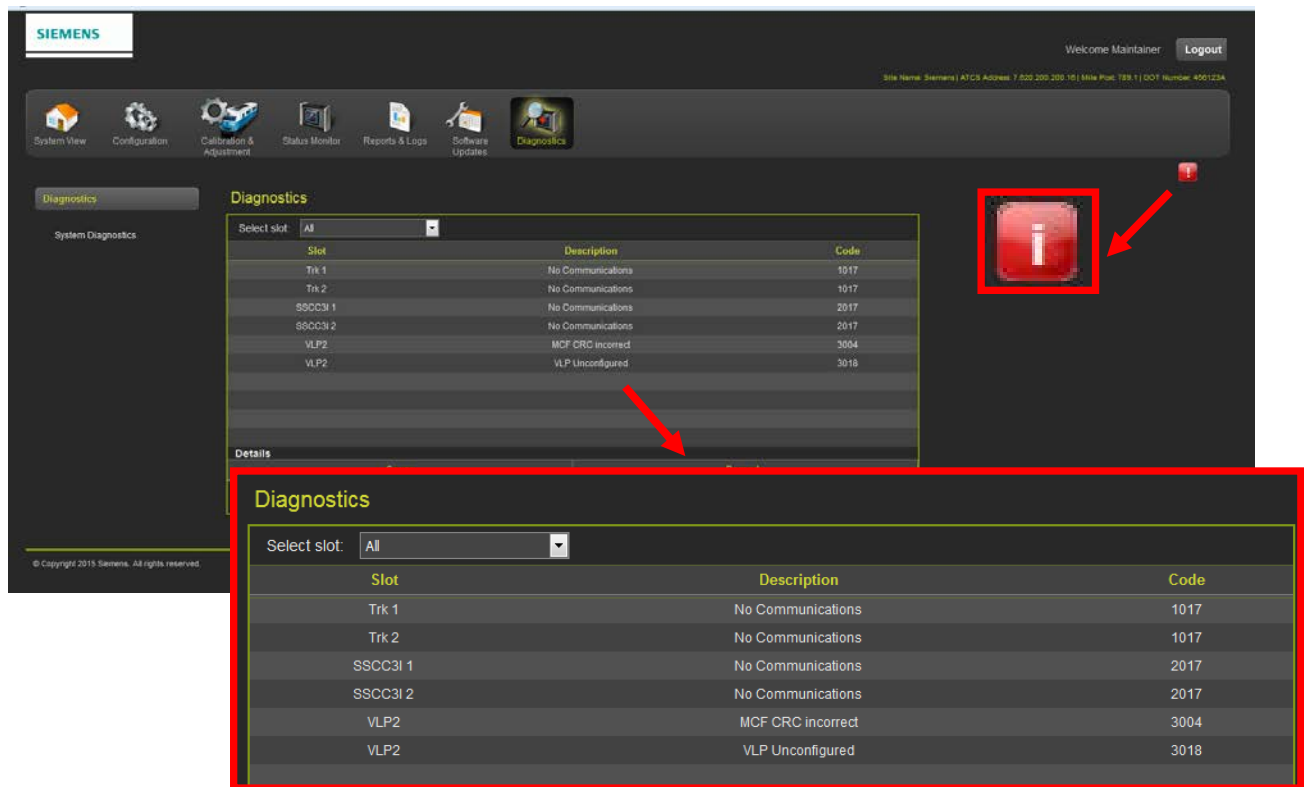

Figure 3-121 CPU III Web UI – Software Updates – Vital IO Module Download Console Log

### 3.1.8 CPU III Web UI - Diagnostics

The System Diagnostics screen provides information on system anomalies that occur from time to time. In the example below, communications have been lost, the MCF CRC is incorrect, and the VLP is unconfigured. The attention icon appears in the right corner of all Web UI screens when a Diagnostic incident is present.



#### DIAGNOSTIC ICONS





-  **Diagnostics Alert Icon**
-  **No VLP Communications Link**
-  **Creating MCF Database**
-  **Processing AUX Files**
-  **Creating Real Time Database**

Figure 3-122 CPU III Web UI – Diagnostics - Diagnostics Screen and Icons

### 3.1.9 CPU III Web UI – Unlock Procedure

The GCP System is “Locked” to prevent accidental changes made to the system that could render an inoperative and/or restrictive condition. Therefore, an unlocking procedure is required to ensure the safety of trains, vehicles, and pedestrians. Any time the system is unlocked, a local maintainer must be present at the equipment whether accessing the system locally or remotely. The following procedure is used to unlock the system:

When Unlocking the system is required, click on the Unlock button [1], a pop-up screen will appear to send a request to the CPU III display for the local presence person to acknowledge, press the OK button [2]. At the site the CPU III display will scroll ...LUP REQ PRESS SEL... [3] for one minute. The local presence person presses the Select (SEL) button [4] and the CPU III display will acknowledge with OK [5]. The remote user will receive a confirmation [6] that authentication has been successful.

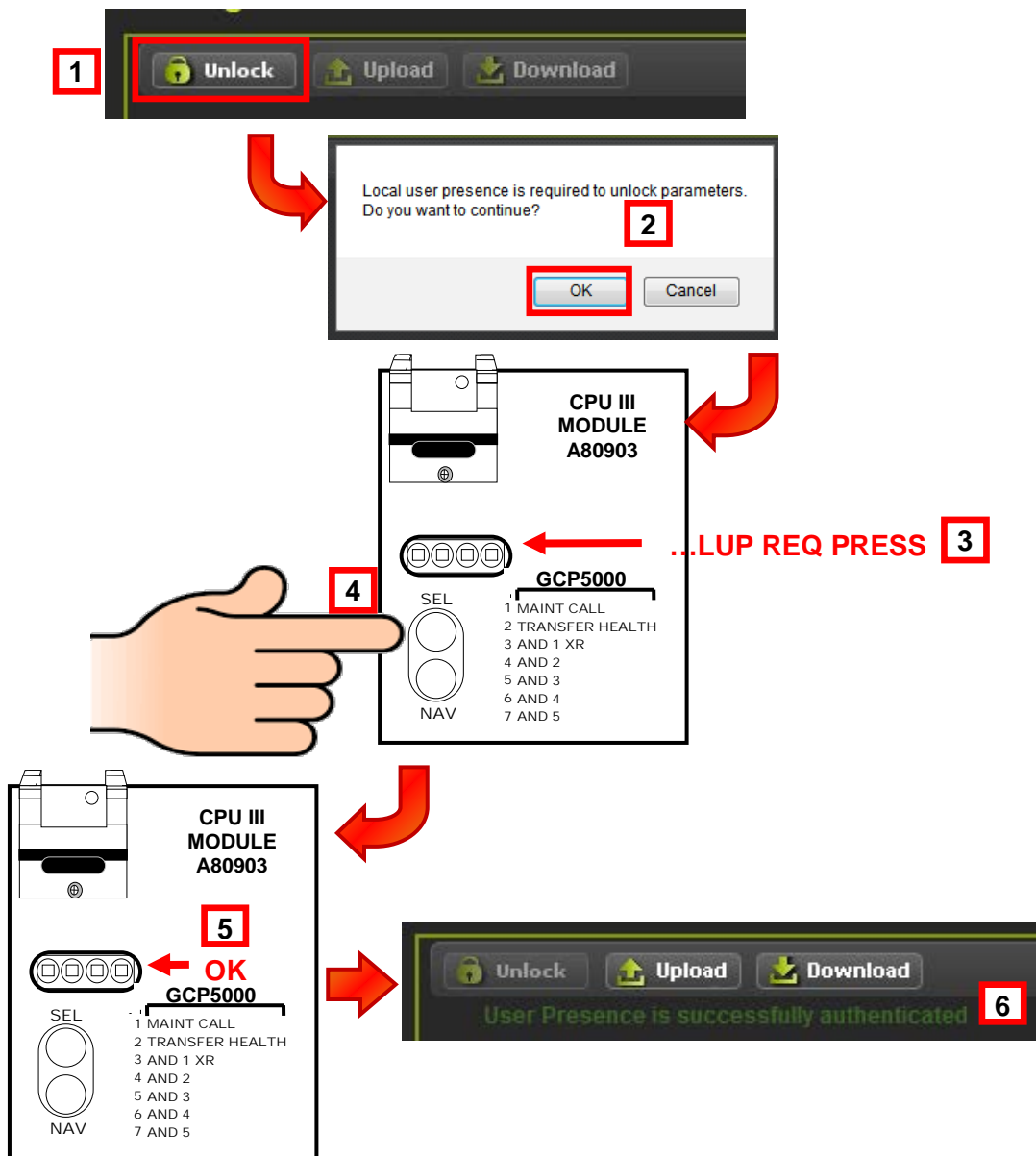

Figure 3-123 CPU III Web UI – Unlock Procedure

### 3.1.9.1 CPU III Web UI – Unlocking Procedure – Reset VLP Module

After unlocking the system, most procedures will include resetting the VLP module to restore system operation. In the event a procedure is cancelled or does not include resetting of the VLP module, it will be necessary to manually reset the VLP module to restore the system from the restrictive state to normal operation. Use the following procedure to rest the VLP Module:

To manually reset the VLP Module navigate to the Software Updates [1] menu. From the Software Updates menu expand the VLP Menu [2] and select the Reset VLP Module Menu [3]. Click on the Reset VLP button [4], a pop-up screen [5] will appear to verify the CPU is to be rebooted. A confirmation screen [6] will appear confirming the CPU has been rebooted.

Verify no alarms are present (no Diagnostic icons on the screen) and the system is operating properly.

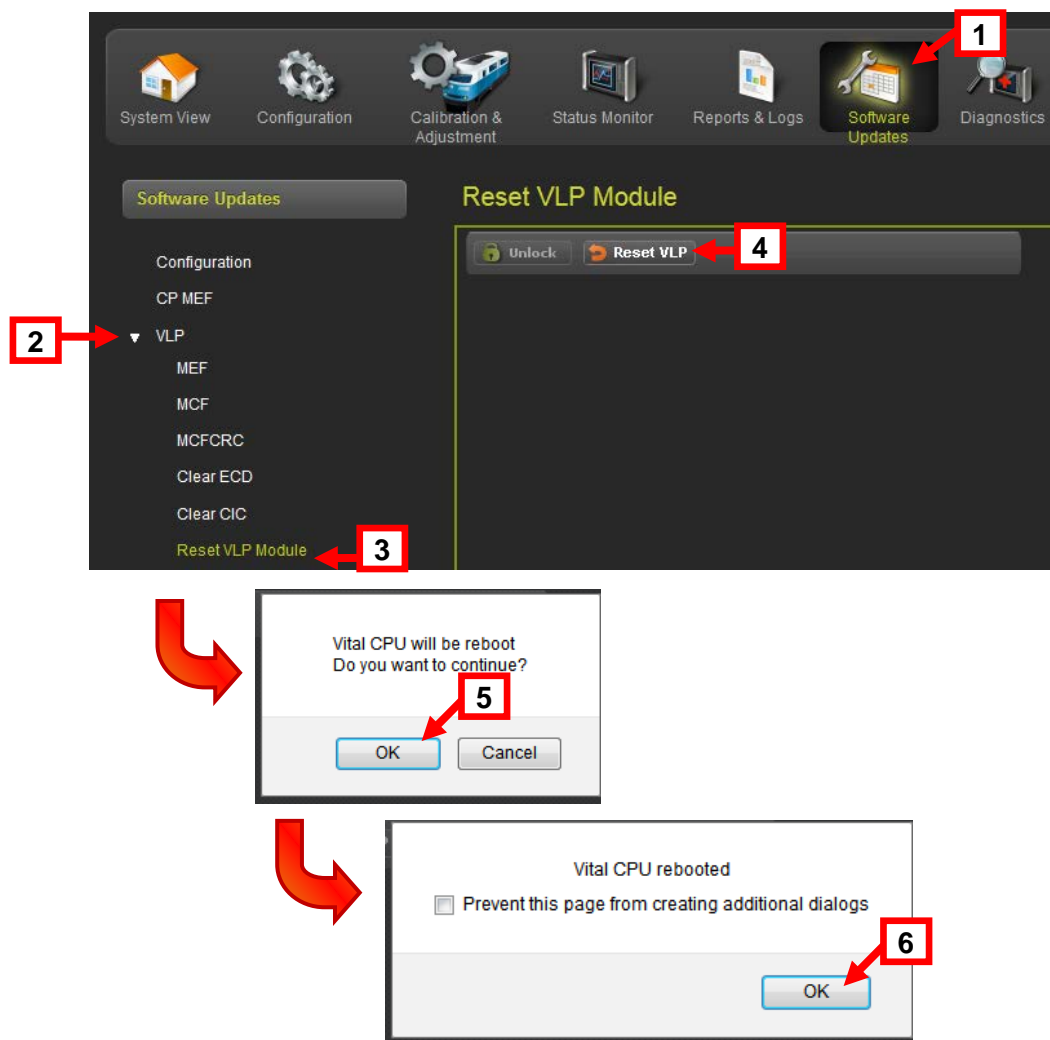

Figure 3-124 CPU III Web UI – Unlocking Procedure - Reset VLP Module

## SECTION 4 – USING CPU III WITH A DISPLAY MODULE

### 4.0 USING CPU III WITH A DISPLAY MODULE

#### 4.1 GENERAL

When a CPU III module is installed in a GCP equipped with a Display Module, the Display Module will control the majority of the user functions. This section will describe the functions available from the CPU III.

##### 4.1.1 System View

None of the user functions under the System View menu are available when the Display Module is installed. The screen will display “**Display in Session**”.

##### 4.1.2 Configuration

The following user functions are available under the Configuration menu when the Display Module is installed.

###### 4.1.2.1 CP Programming – Laptop Port

See Sections 3.1.2.9 and 3.1.3.11 for screen examples and details.

###### 4.1.2.2 CP Programming – Web Server

See Sections 3.1.2.9 and 3.1.3.13 for screen examples and details.

###### 4.1.2.3 CP Programming – Set to Default

See Sections 3.1.2.9 and 3.1.3.14 for screen examples and details.

##### 4.1.3 Calibration & Adjustment

None of the user functions under the Calibration & Adjustment menu are available when the Display Module is installed. The screen will display “**Display in Session**”.

##### 4.1.4 Status Monitor

The following user functions are available under the Status Monitor menu when the Display Module is installed.

###### 4.1.4.1 Ethernet Status

See Section 3.1.5 for screen examples and details.

###### 4.1.4.2 Route Table

See Section 3.1.5 for screen examples and details.

#### **4.1.4.3 Statistics**

See Section 3.1.5 for screen examples and details.

### **4.1.5 Reports & Logs**

The majority of the user functions are available from the CPU III with the Display Module installed.

#### **4.1.5.1 CP Status Log**

See Section 3.1.6.5 for example screens and details.

#### **4.1.5.2 Train History**

See Section 3.1.6.10 for screen examples and details.

#### **4.1.5.3 Maintenance Log**

See Section 3.1.6.11 for screen examples and details.

#### **4.1.5.4 Reports**

See Section 3.1.6.12 for screen examples and details.

#### **4.1.5.5 EZ/EX Recording**

See Section 3.1.6.18 for screen examples and details.

#### **4.1.5.6 Track Data**

See Section 3.1.6.20 for screen examples and details.

#### **4.1.5.7 VLP/IO Card Logs**

The VLP/IO Card Logs are not available when the Display Module is installed.

#### **4.1.5.8 Check Numbers**

The Check Numbers user function is not available when the Display Module is installed.

### **4.1.6 Software Updates**

The majority of the user functions are available as follows:

#### **4.1.6.1 Configuration**

The Configuration user function is not available when the Display Module is installed.

#### **4.1.6.2 CP MEF**

See Section 3.1.7.3 for screen examples and details.

#### **4.1.6.3 VLP**

All of the VLP menus are available when the Display Module is installed. See the following sections for screen examples and details:

##### **CP MEF**

See Section 3.1.7.3.

##### **VLP – MEF**

See Section 3.1.7.4.

##### **VLP – MCF**

See Section 3.1.7.5.

##### **VLP – MCFCRC**

See Section 3.1.7.6.

##### **VLP – Clear ECD**

See Section 3.1.7.7.

##### **VLP – Clear CIC**

See Section 3.1.7.8.

##### **VLP – Reset VLP**

See Section 3.1.7.9.

#### **4.1.6.4 Vital IO Module**

See Section 3.1.7.10 for example screens and details.

#### **4.1.7 Diagnostics**

The Diagnostics user function is not available when the Display Module is installed. The screen will display “**Display in Session**”.

#### **4.1.8 GCP4000**

In a GCP4000 the configuration is stored in the CIC on the backplane and accessed via the CPU module. The SEAR Ili has to be programmed via the terminal interface on the front of the SEAR Ili module. In the case of a GCP4000 it does not matter whether the programming is done via the Display Module or via the CPU III (if the Display module was not plugged in at the time).

#### **4.1.9 GCP5000**

In a GCP5000 there are two places where the configuration is stored. The vital MCF configuration is stored in the CIC on the backplane and accessed via the CPU module. The non-vital configuration, which includes the SEAR Ili configuration, is stored on a USB ECD accessed by the display. The subset of the non-vital configuration which is used by the CPU III is also stored on CIC accessed by the chassis. This is so if the display is removed, or went bad, the CPU III would still have access to the non-vital information it needs.

This includes:

- Site information
- Verbosity settings

The Display is the master of this non-vital configuration, so if changes need to be made to these, make the changes via the Display module user interfaces, do not remove the Display and program directly via the CPU III Web UI, or else the settings received from the display will override the ones stored in the CPU's CIC if the display is plugged in again.





## SECTION 5 – CPU III SETUP – EXISTING GCP4000/5000

### 5.0 CPU III – GCP4000/5000

#### 5.1 GENERAL

For an existing GCP installation that uses the CPUII+ (A80403-001/005) module, the CPU III can be used as a drop in replacement. The CPUII+ can be removed and the CPU III plugged into its slot. The CPU III will first read the MCF from the ECD and transfer it across to the VLP; this may take a few minutes. The 4 character display will show “MCF XFER” and a percentage complete during the transfer process.

When the 4 digit display on the CPU III scrolls the MCF number, the Web UI will be available. To find the IP Address for the Laptop port, press the NAV button on the front panel of the CPU III several times until the 4 character display shows IP: xx.xx.xx.xx. If the user logs into the Web UI while the MCF is still being transferred it will show the “No VLP Communications” icon in the top right.

Once the MCF has transferred the VLP will reboot and will come up fully operational (assuming the GCP installation was in operational previously). The WebUI will then show the “Creating MCF Database”  icon . This may take several minutes to complete, this only occurs once during the initial time the CPU loads this MCF. Once the MCF is loaded the CPU will process the AUX files. The AUX icon  will appear during the process. The CPU will create the Real Time Database and display the RT icon  during the creation period. When complete the WebUI will show the System view screen.

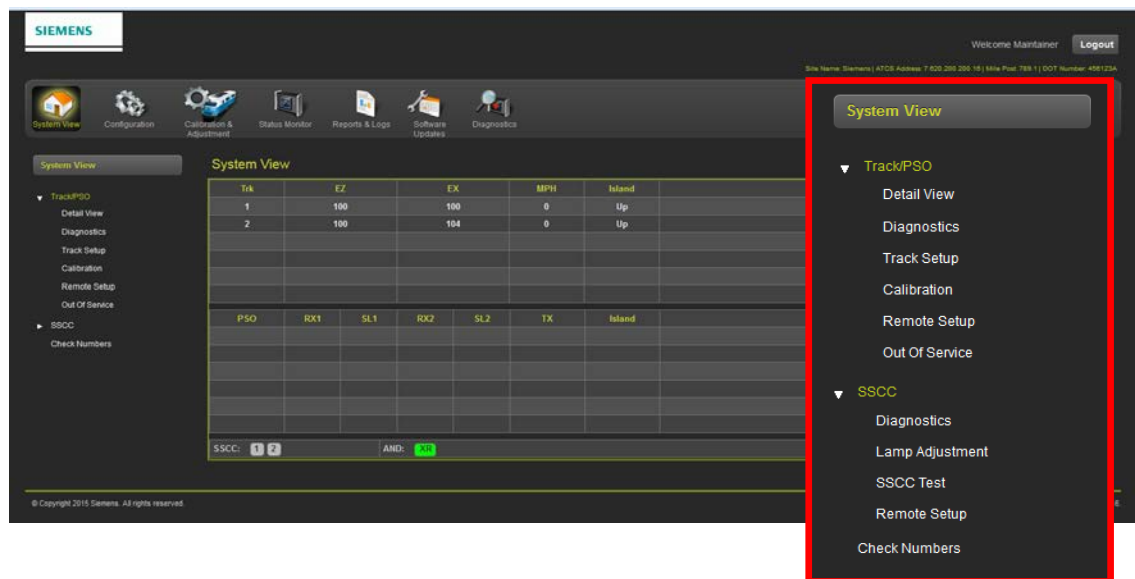
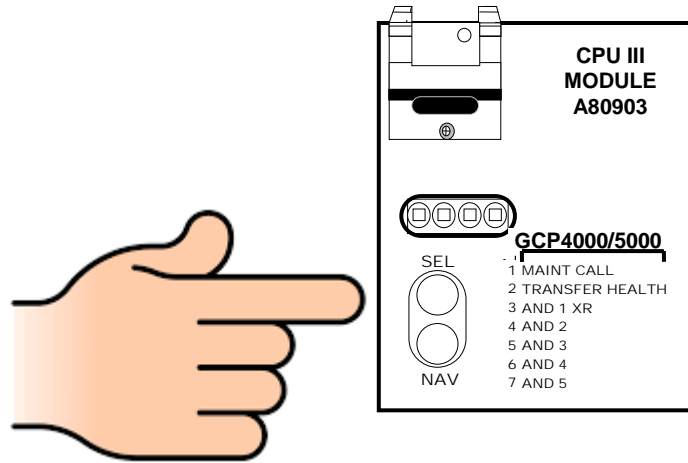

Figure 5-1 System View Screen

In the SGCP/MS4000 application, the push buttons on front of the CPU III can be used to program the configuration parameters in a similar manner when using a CPUII+.



**Figure 5-2 Using CPU III Push-Buttons on SGCP/MS4000**

## **5.2 NEW GCP4000/5000 INSTALLATION APPLICATION (NO DISPLAY MODULE)**

If installing a new GCP4000/5000 installation using the CPU III with no Display Module, refer to Sections 2 and 3 of this manual.