

SIEMENS

P1-400 Panelboard Kit 42NLK30A, 42NLK42A, 42NLK54A with 200% Neutral (for use in Revised P1 Panelboards ONLY)¹

Installation
Instructions

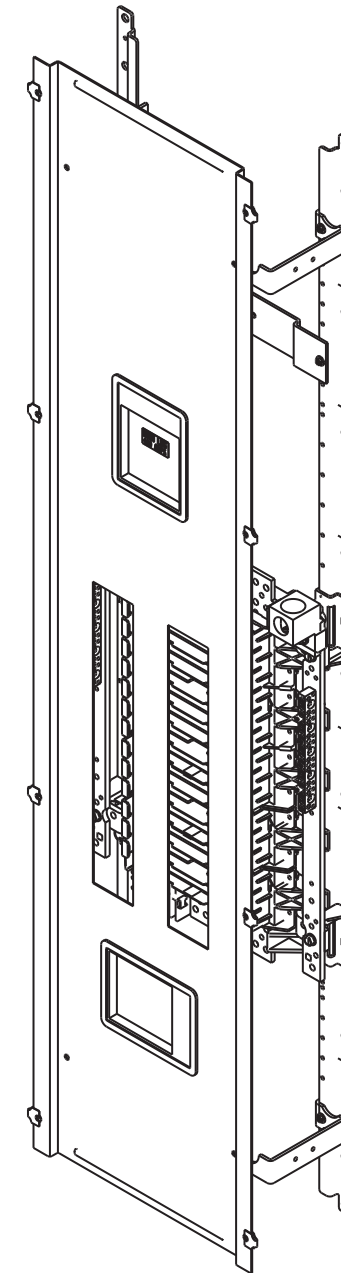

These instructions do not purport to cover all details or variations in equipment, or to provide for every possible contingency to be met in connection with installation, operation or maintenance. Should further information be desired or should particular problems arise, which are not covered sufficiently for the purchaser's purposes, the matter should be referred to the local Siemens sales office. The contents of this Instruction manual shall not become part of or modify any prior or existing agreement, commitment or relationship. The sales contract contains the entire obligation of Siemens. The warranty contained in the contract between the parties is the sole warranty of Siemens. Any statements contained herein do not create new warranties or modify the existing warranty.

Trademarks - Unless otherwise noted, all names identified by ® are registered trademarks of Siemens AG or Siemens Industry, Inc. The remaining trademarks in this publication may be trademarks whose use by third parties for their own purposes could violate the rights of the owner.

¹ To confirm, note the part number of the panel (marked on the interior label). If it ends in an "N" or a "T" it is a "Revised P1" and is compatible with this kit. (For example: P1E42MC250A is an Original P1; P1E42MC250AT is a Revised P1)

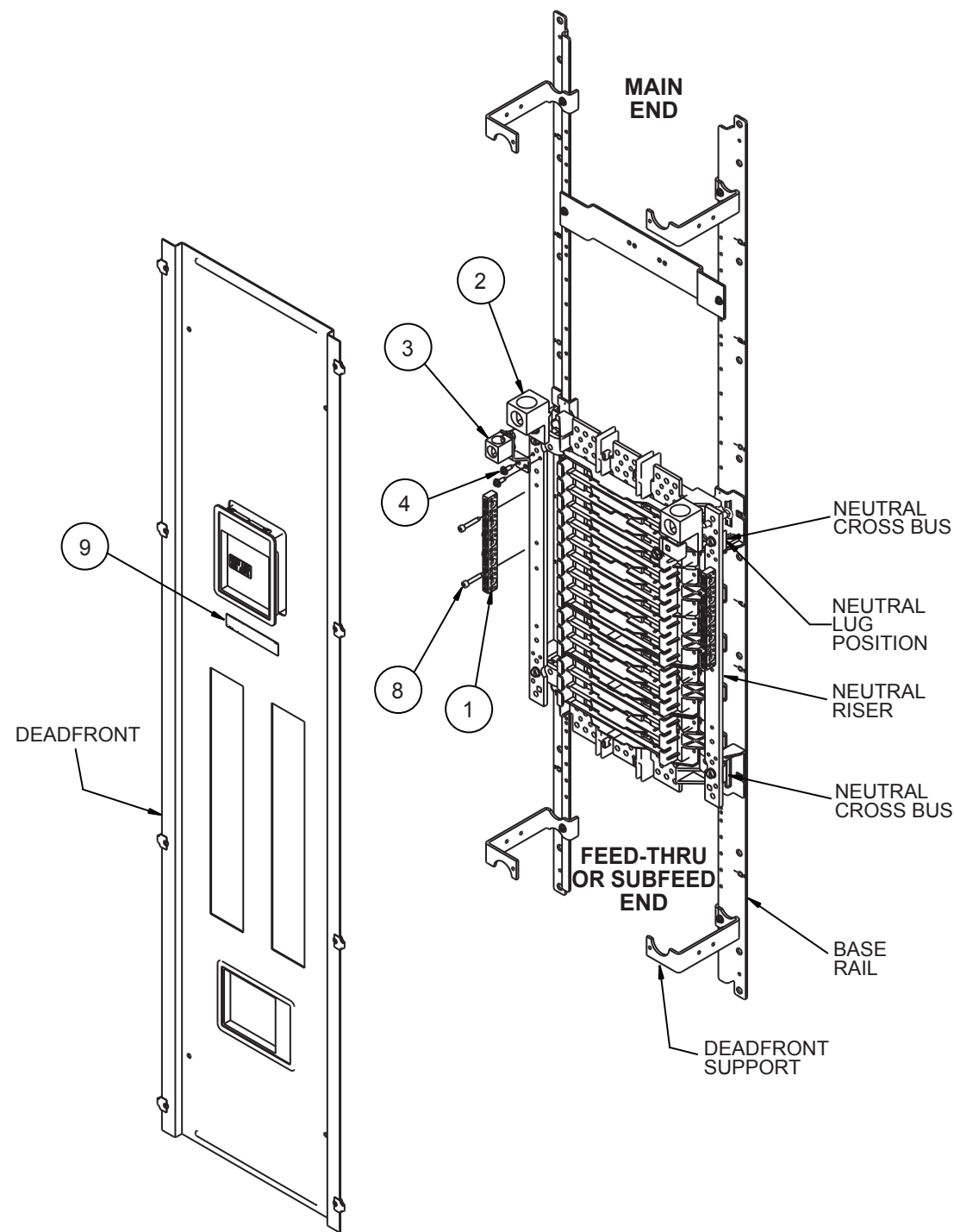

THIS KIT CONTAINS THE FOLLOWING ITEMS:

ITEM	DESCRIPTION	QTY
1	BRANCH NEUTRAL CONNECTOR STRIP (for COPPER cable ONLY)	*
2	600 kcmil NEUTRAL LUG	1
3	SERVICE GROUND ELECTRODE LUG	1
4	#10-24 x 9/16" THREAD-FORMING SCREW	2
5	1/4"-20 x 1" CARRIAGE BOLT	1
6	1/4"-20 BELLEVILLE WASHER NUT	1
7	ANTI-TURN PLATE	1
8	#10-24 x 1-1/8" SOCKET HEAD THREAD-FORMING SCREW	**
9	200% LABEL	1

* (2) for 42NLK30A & 42NLK42A; (4) for 42NLK54A

** (4) for 42NLK30A & 42NLK42A; (8) for 42NLK54A

Installation Instructions

The following instructions are for the installation of a Siemens 200% rated neutral kit in a Revised P1, 400 amp Panelboard. The parts provided in this kit are for connection to a 1-phase 3-wire system or a 3-phase 4-wire system. The 42NLK**A kits are for 200% rated neutrals sometimes required for panels supplying loads with high harmonic loads, such as personal computers. Caution: The 200% neutral requires that the line cable and connectors be doubled, for example instead of (1) cable for 400 amp panel use (2) cables. This kit provides a single 600 kcmil line lug to be used in conjunction with the 600 kcmil neutral line lug supplied with the main lug or main breaker assembly installed in the panelboard to meet the double cabling requirement. Kits include 42NLK30A, 42NLK42A & 42NLK54A for panelboards with 30, 42 & 54 circuits, respectively. (NOTE: Use 42NLK54A for 66 circuit panelboards.)



1. Lock off all power supplying this equipment before working on it.
2. Remove the deadfront.
3. Remove the existing neutral terminal strips (item 1) and replace them with the strips provided in this kit. Use the #10-24 x 1-1/8" socket head thread-forming screws (item 8) to fasten them to the neutral risers.
4. Determine which of the line neutral lug positions does not have a 600 kcmil lug installed. If there is a smaller lug mounted there, remove it. Insert the 1/4"-20 x 1" carriage bolt (item 5) through the square hole on the neutral riser from below, then place the 600 kcmil lug (item 2) and the anti-turn plate (item 7) as shown. Finish with the 1/4"-20 belleville washer nut (item 6).
5. To mount the service ground electrode lug (item 3) -- if required for service equipment applications -- position the lug assembly on top of the neutral riser and align the two thru-holes with those on the riser. Fasten with (2) of the #10-24 x 9/16" thread-forming screws (item 4).
6. Torque all connections to the values specified on the Hardware Tightening Torque label affixed to the rear of the deadfront.
7. Attach main cables to the lugs and branch cables to the branch strips. If no torque values are specified on the connectors, refer to the Hardware Tightening Torque label located on the rear of the deadfront.
8. Place 200% Neutral label (item 9) on the front of the deadfront (or the rear if no room on the front).
9. Before energizing the panel, ensure that all connections have been properly torqued, that the deadfront is installed and that all fillers are in place.

