

SIEMENS

Operating Instructions -
MTR4.2-003ab

Three-phase induction motor Type 1LA8

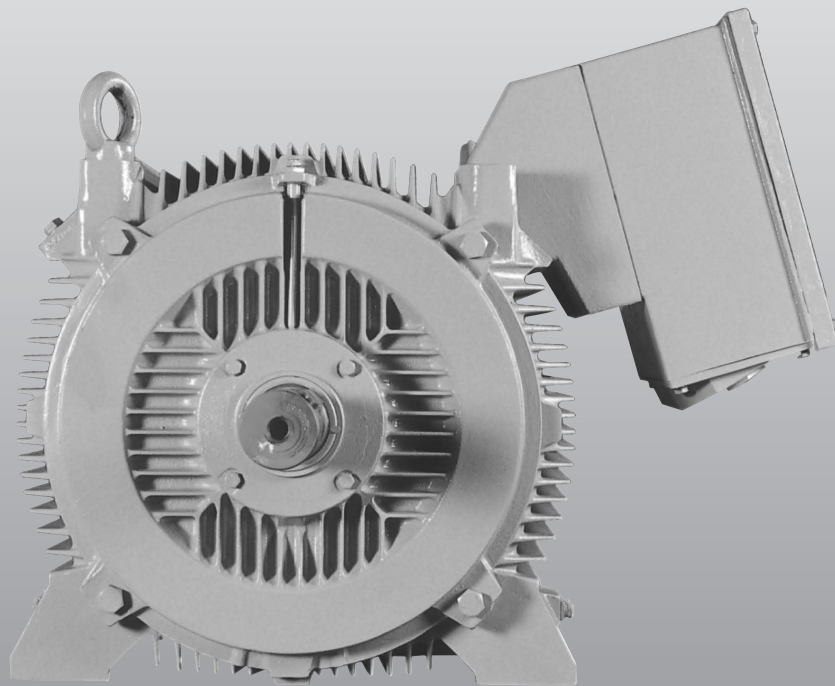

Table of content

1	Safety information	1
1.1	Definitions, warning information	1
1.2	Safety and application information	2
1.3	Operation in locations subject to explosion hazards	2
1.4	Electromagnetic compatibility	2
2	Description, technical data	3
2.1	Scope of delivery	3
2.2	Siemens Service Center	3
2.3	Applications	3
2.4	Design of the motor	3
2.5	Main Terminal Boxes	4
3	Transport, installation and assembly	8
3.1	Transport, storage	8
3.2	Installation	9
3.3	Aligning	10
3.4	Mounting	11
3.5	Connecting the ground conductor	11
3.6	Connection of the motor	12
3.7	Connection to the converter	14
3.8	Converter operation on a grounded network	14
4	Commissioning	15
4.1	Preparations	15
4.2	Measures to be taken prior to commissioning	16
4.3	Monitoring the temperature of the stator winding	16
4.4	Energizing	16
4.5	De-energizing	17
5	Operation	18
5.1	Safety information	18
5.2	Stoppages	18
5.3	Fault diagnosis table	18
6	Maintenance	21
6.1	Maintenance	21
6.1.1	Preparations for maintenance	21
6.1.2	Bearings	21
6.1.3	Regreasing with sealing grease (option for increased degree of protection)	22
6.2	Servicing	22
6.2.1	Servicing instructions	22
6.2.2	First service after installation or repair	22
6.2.3	Main service	23
6.3	Repair	23
6.3.1	Preparations for overhauling / repairs	23
6.3.2	Dismantling	23
6.3.3	Dismantling instructions	23
6.3.4	Re-assembly	24
6.3.5	Notes on assembling the bearing seal	25
6.3.6	Assembling the fan	25
6.3.7	Bolt locking devices and tightening torques	25
6.3.8	Spare Parts	25
6.3.9	Exploded View – 1LA8 Motor	26
7	Storage	27
8	Annexure-1 – Additional Operating Instructions for 1PQ8 Motors	28
9	Annexure-2 – Connecting the Grounding Conductor	30
10	Annexure-3 – Converter Operation	31

1 Safety information

1.1 Definitions, warning information

Warning

The data and recommendations specified in all the instructions supplied, and in all other related instructions, must always be observed in order to avoid hazardous situations and the risk of possible injury or damage.

Furthermore, the pertinent national, local and plant-specific regulations and requirements should be kept in mind!

Special designs and other versions may vary in technical details! If in doubt, be sure to contact the manufacturer, quoting the type designation and serial number, or have maintenance work done by one of Siemens Service Centers.

Qualified persons

Only qualified persons who have carefully read and understood the content of this documentation should be entrusted with the commissioning and operation of machines, equipment or systems. Qualified persons as far as the safety instructions given in this documentation are concerned are those who have the necessary authorization to commission, earth and identify equipment, systems and circuits in accordance with the relevant safety standards.

Safety guidelines

This documentation contains instructions, which must be followed closely in order to ensure personal safety and avoid damage to the equipment and machines.

Personal safety instructions are highlighted in the manual by a warning triangle, while damage avoidance instructions are not. They are marked as follows depending on the level of danger:

Danger

Danger means that death or grievous injury will occur if the appropriate precautions are not taken.

Warning

Warning means that death or grievous injury may occur if the appropriate precautions are not taken.

Caution

Caution with a warning triangle means that minor personal injury may occur if the appropriate precautions are not taken.

Caution

Caution without a warning triangle means that damage to property may occur if the appropriate precautions are not taken.

Notice

Notice means that an undesirable result or state might occur if the relevant instructions are not followed.

Note

Note draws particular attention to an important item of information about the product, its use or the corresponding section of the documentation, which could be useful to the user or operator.

Proper usage

Please pay close attention to the following:

Warning

The electrical equipment contains components that are at a dangerous voltage. Before any work is carried out, therefore, it must be ensured that the equipment is isolated from the supply.

Only qualified persons may work with this equipment.

These persons must be familiar with all instructions and precautions to be taken / specified in this documentation that are relevant for safety.

Safe and satisfactory operation of this motor presumes satisfactory transport, proper storage, installation and assembly and careful subsequent operation and maintenance.

This motor may only be used for the applications specified in the catalog and the technical description, and only in conjunction with third-party devices and components recommended and/or approved by Siemens.

Failing to adhere to these instructions may result in severe injury and/or damage to property.

National safety regulations must be closely observed.

1.2 Safety and application information

The safe use of electrical machines



These electrical machines are designed for use in industrial power systems.

Rotating or live and uninsulated parts pose a danger.

There is consequently a risk of fatal or severe personal injury or substantial damage to property if the necessary covers are removed without authorization or if the equipment is handled improperly, operated incorrectly or maintained inadequately.

If the motors are used outside industrial areas, the installation site must be safeguarded against unauthorized access by means of suitable protection facilities (e.g. fencing) and appropriate warning signs.

The persons responsible for the safety of the system are under an obligation to ensure that:

- The basic planning work for the system and all work relating to transportation, assembly, installation, commissioning, maintenance and repairs are carried out by qualified persons and checked by responsible, suitably skilled persons.
- These instructions and the motor documentation are made available at all times while work is in progress.
- The technical data and specifications relating to the permissible installation, connection, ambient and operating conditions are taken into account at all times.
- The system-specific erection and safety regulations are observed and personal protective gear is used.
- Work on these machines, or in the vicinity of these machines, by unqualified persons is prohibited.

These instructions therefore only contain the information, which is necessary for the motors to be used by qualified persons in accordance with their intended purpose.

Note

We recommend engaging the support and services of your local Siemens service center for all planning, installation, commissioning and maintenance work.

1.3 Operation in locations subject to explosion hazards

Note

1LA8 Motors are designed and manufactured for operations in safe zones only



Binding clarification of the local risks and of any measures necessary is only possible by the user of the installation in agreement with the supervisory authority responsible.

Installation-specific ignition hazards

The criteria for the respective zonal classification are not harmonized and the assessment of the operational risks, the local operating conditions and the various monitoring methods is not uniform. Accordingly, the remedial measures recommended by the supervisory authorities also differ in some cases, depending on the authority's area of responsibility. It is not possible for the machine manufacturer to issue generally applicable recommendations in this respect.

Note

Binding clarification of the local risks and of any measures that should be recommended is only possible by the user in agreement with the supervisory authority responsible for the respective installation.

1.4 Electromagnetic compatibility

Instructions relevant for safety

Notice

If the load torque is very irregular (e.g. when driving a reciprocating compressor) a non-sinusoidal motor current will be induced whose harmonics might bring about an excessive reaction on the supply system and so cause excessive emitted interference on the power supply connecting leads.

Notice

If operated through a frequency converter, the emitted interference is varying in strength, depending on the design of converter (type, interference suppression measures and manufacturer). In order to avoid exceeding the limit values on the drive system, consisting of motor and converter, the EMC information given by the converter manufacturer must strictly be observed. On motors with integrated sensors (e.g. PTC thermistors) it is possible that interference voltages caused by the converter occur on the sensor lead.

If using motors with integrated sensors, the operator himself must ensure sufficient interference immunity by selecting a suitable sensor signal lead and a suitable evaluation unit.

2 Description, technical data

2.1 Scope of delivery

Checking the scope of delivery for completeness

When you take receipt of the delivery, please check immediately whether the scope of the delivery matches up with the accompanying documents. Siemens will not accept any warranty claims relating to items missing from the delivery that are submitted later.

Register a complaint about:

- Any transport damage detected immediately with the delivery agent.
- Any defects/incomplete delivery detected immediately with the SIEMENS representative responsible.

These Operating Instructions belong to the scope of delivery and must be kept where they can be easily accessed.

2.2 Siemens Service Center

Contact for further information

Details about the design of the three-phase motor supplied and about the permissible operating conditions are described in these Operating Instructions.

If you have any questions or suggestions, or if you require further information, please contact the Siemens Service Center.

2.3 Applications

Overview

1LA8 three-phase AC machines have been designed for a very wide range of drive applications and energy conversion applications. This series distinguishes itself as a result of its ruggedness, high lifetime and reliability. Not only this, it is extremely versatile, which allows it to be optimally adapted to the particular application and function.

A description of the motor and permissible operating conditions are specified in this documentation.

2.4 Design of the motor

Standards

The motors are compliant with the following standards:

- IS 12615: Line Operated Three Phase a.c. Motors (IE CODE) "Efficiency Classes and Performance Specification
- IS: 900: Code of practice for installation and maintenance of induction motors.
- IS: 7816: Guide for testing insulation resistance of rotating machines.

- IS: 12065: Permissible limits of noise level for rotating electrical machines.
- IS: 12075: Mechanical vibration of rotating electrical machines with shaft heights 56mm and higher – Measurement, Evaluation and Limits of Vibration severity.
- IEC: 60034-1: Rotating electrical machines – Part 1: Rating and Performance.
- IEC: 60034-5: Degree of protection for rotating electrical machines.

Cooling and ventilation

The series 1LA8 motors are totally enclosed fan-cooled three-phase squirrel cage motors with an internal air-cooling circuit for cooling.

Located at the non-drive end of the stator housing is an air intake cowl that guides the external air. The external air is drawn in through an opening in the air intake cowl and flows axially across the outer cooling ribs of the motor frame. The fan impellers for the inner and outer cooling airflow are mounted on the motor shaft. The cooling method is as per IC411 (or IC4A1A1) of IEC 60034-6.

Caution

Normally, external fans for two-pole motors are unidirectional, and for machines with four or more poles are bidirectional. Machines with unidirectional external fans are identified on the Fan cowl with an additional label showing the direction of rotation. The internal fans are generally bidirectional. In the event that the level of cooling provided by the internal cooling system is not sufficient it is also possible to attach a separate fan. This type of fan provides a sufficient level of cooling irrespective of the speed of the main motor. Temperature sensors are integrated in the stator winding to monitor the winding temperature. Various supplementary devices can be integrated or mounted, depending on the order. These include, for example, anti-condensation heating, bearing temperature monitoring or other devices.

Rotor and rotor winding

The rotor assembly is pressed onto the shaft together with the squirrel cage winding. The drive end of the shaft usually has a cylindrical shaft end.

Storing

The motors are equipped with different types of rolling-contact bearings depending on the version and the operating conditions described in the order. The different types are listed on the lubrication plate of the motor. In converter operation an insulated bearing is usually installed on the non-drive end.

Caution

Compliance with the permissible loads for the forces at the end of the shaft must be ensured in accordance with the catalog data, as otherwise bearing damage may occur.

2.5 Main Terminal boxes

The terminal box can be arranged either on the left or right of the machine. It is not possible to subsequently swap the position to the other side of the machine at a later date. Please consult Siemens if you subsequently need to convert the machine to the next larger size

of terminal box. Depending on size, the following terminal boxes are generally used for connecting the cables:

Motor Type	Standard Terminal Box	Larger Terminal Box
1LA8 353/355/356-2..8	1XB7 622	1XB1 631
1LA8 357-6..8	1XB7 622	1XB1 631
1LA8 357-2..8	1XB1 631	Not Applicable
1LA8 358-4	1XB1 631	Not Applicable
1LA8 40-2..8	1XB1 631	1XL 7010
1LA8 452/454/456-4..8	1XB1 631	1XL 7010
1LA8 460/462-4..8	1XB1 631	1XL 7010

Main Terminal Box - 1XB1 622

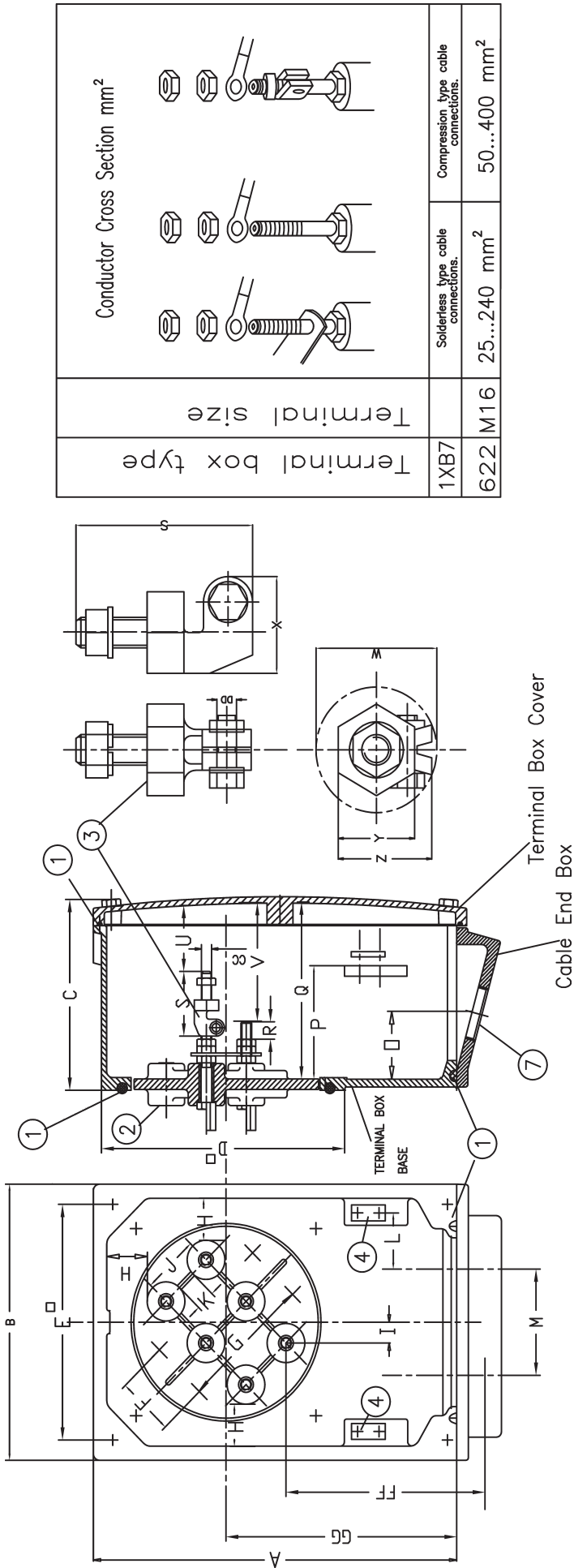

Terminal Box	A	B	C	D	E	F	G	H	I	J	K	L	M	O	P	Q	R	S	U	V	W	X	Y	Z	CC	DD	⑥ ² mm ²	FF	GG
1XB7 622	422	324	229	306	240	84	196	29	30	84	30	60.5	135	87	156	206	25	91	63.5	116	62	48	41	48	M16	M10	400	187	260

- ① Rubber gasket
- ② Terminal block
- ③ Terminal connection assembly
- ④ Earthing clamp
- ⑤ Distance from center of conduit entry hole
- ⑥ Max. permissible size of conductor
- ⑦ 2 Nos. Conduit Entry M72x2.

Main Terminal Box - 1XB1 631

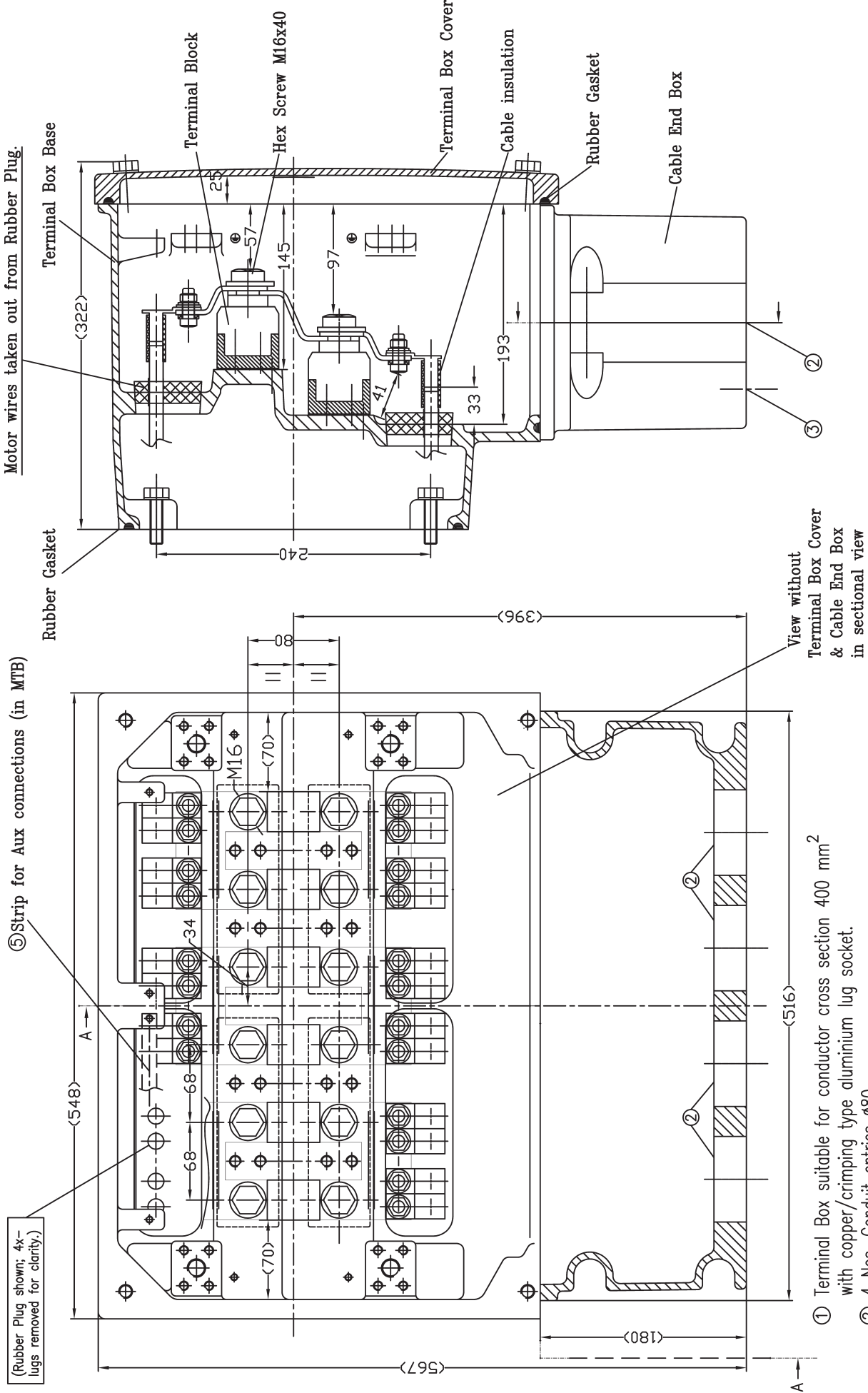

- ① Terminal Box suitable for conductor cross section 400 mm² with copper/crimping type aluminium lug socket.
- ② 4 Nos. Conduit entries Ø80
- ③ 2 Nos. Conduit entries 19(3/4") - IS:1653.
- ④ Terminal box base, Cover & Cable End Box of C.I.
- ⑤ All auxiliary connections are located inside Main Terminal Box.

Main Terminal Box - 1XL 7010

- ① Terminal Box suitable for conductor cross section 400 mm² with copper/crimping type aluminium lug socket.
- ② 6 Nos. Conduit entries $\varnothing 80$
- ③ Terminal box base, cover & Cable Entry Plate of Mild Steel

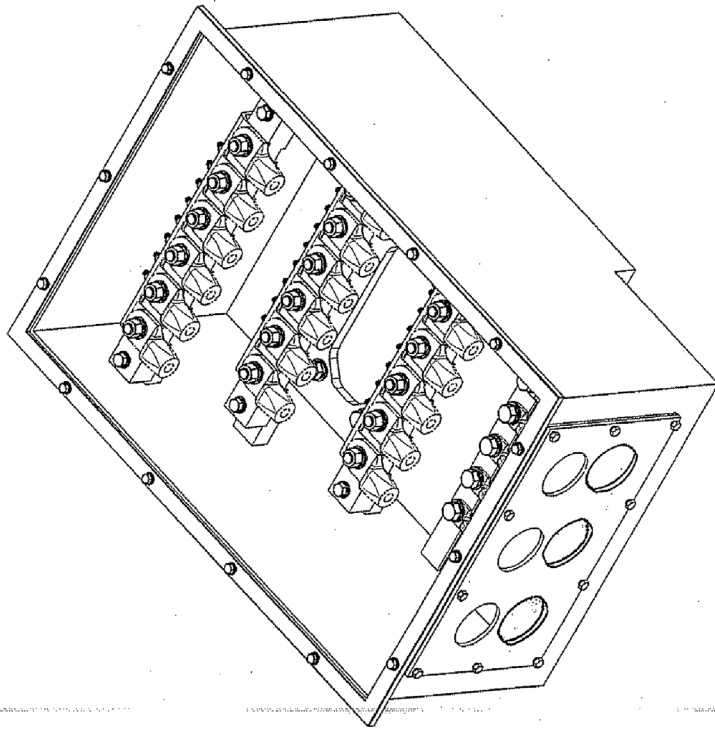
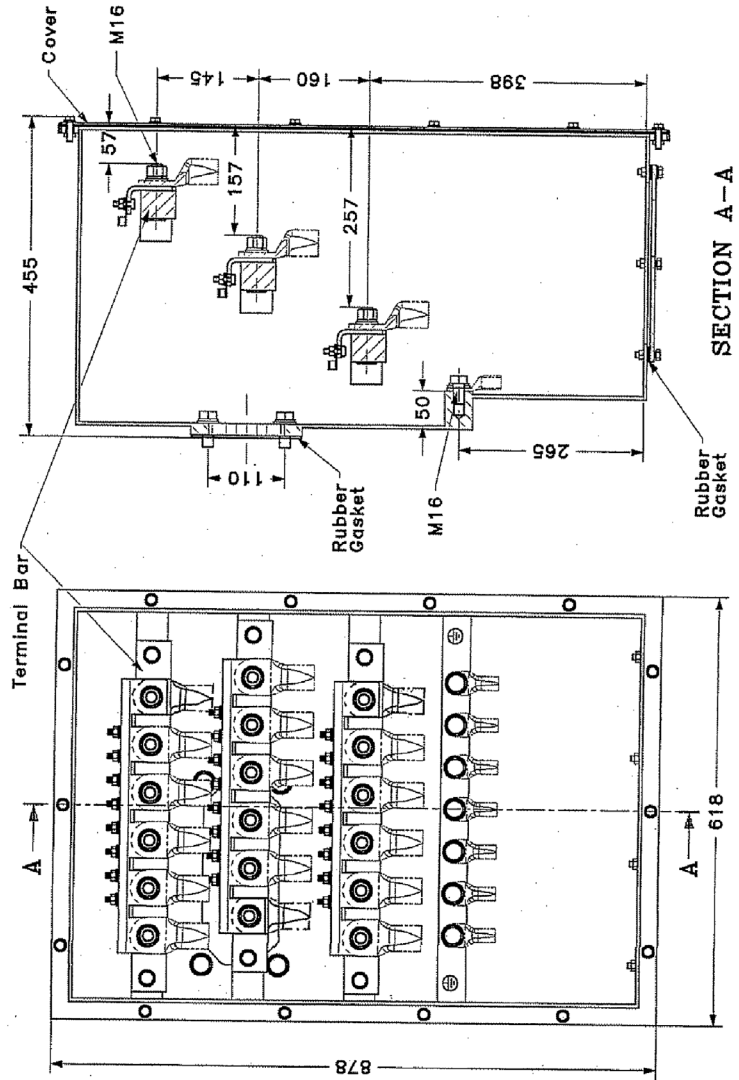
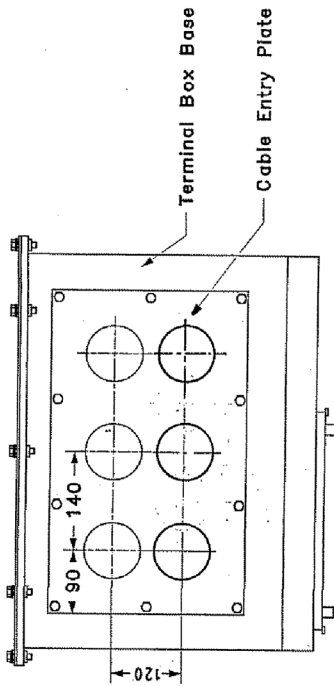

3D VIEW SHOWN WITHOUT TERMINAL BOX COVER

VIEW SHOWN WITHOUT TERMINAL BOX COVER

3 Transport, installation and assembly

3.1 Transport, storage

Transport damage

The shipping company must be notified immediately of any damage detected after delivery of the machine. The machine must not be put into operation if any damage is found.

Transportation

Caution

The supplied rotor-locking device must be mounted during transportation in order to prevent damage to the motor. Do not remove this device until before the power take-off element is fitted. If the motor has to be transported after the power take-off element is fitted, other appropriate measures must be taken to fix the axial position of the rotor (see illustration below).

Vertical-design motors must always be transported in the vertical position if the rotor is not locked. If transport in a horizontal position should prove to be necessary in special cases, the rotor must be locked again before the machine is turned. Vertical motors with suitable bearings can be supplied in the horizontal position from the manufacturing plant.

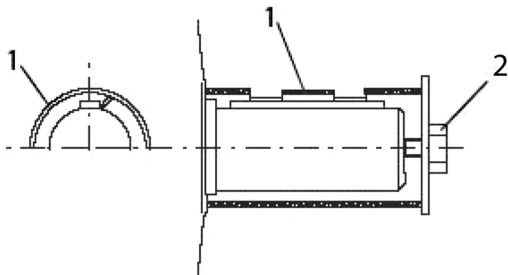

Rotor locking device

Key: 1 sleeve, 2 Shaft bolt and washer

Tightening torques for the shaft bolt of the rotor locking device

Thread in the shaft end	Tightening torque	Preload
M20	50 Nm	12 kN
M24	100 Nm	20 kN
M30	180 Nm	32 kN

Warning

The motors may only be transported and hoisted in a position corresponding to their type of construction (i.e. horizontal construction types in horizontal position and vertical construction types in vertical position). The motors may only be hoisted using the hoisting lugs provided on the stator housing. Use appropriate rope guidance or spreading equipment (for weight see rating plate or technical data).

Warning

Only the intended openings, eyebolts and lifting pin on the base plates may be used for transporting motor sets. Always pay attention to the carrying capacity of the lifting device. Motor sets must not be lifted by attachment to the individual motors.

For lifting assembled machine sets (such as built-on gearboxes, fan units), always use the lifting eyebolt(s) or lifting pegs provided on both the units! Machine sets should not be lifted by suspending the individual machines! Check the lifting capacity of the hoist!

Note: The motors should not be lifted using the centre holes on the shaft DE and NDE, because the weight of the motor shall harm the bearing and reduce its performance and operational life.

Storage

Storing outdoors

If possible choose a dry storage location safe from flooding and free from vibrations. Repair any damage to the packaging before putting the equipment in storage, in so far as this is necessary to ensure proper storage conditions. Position machines, devices and crates on pallets, wooden beams or foundations that guarantee protection against ground dampness. Prevent the equipment from sinking into the ground and the circulation of air underneath the equipment from being impeded.

Covers or tarpaulins used to protect the equipment against the weather must not make contact with the surfaces of the equipment. Ensure adequate air circulation by positioning wooden spacer blocks between the equipment and such covers.

Storing indoors

The storage rooms must be dry, free from dust, frost and vibrations and well ventilated. They must also provide protection against extreme weather conditions.

The motors must be protected against shock and humidity. The rotor-locking device should be installed when the device is put into storage.

Notice

If a motor is not put into operation immediately, it should be stored in a dry room free from dust, frost and vibrations. Aggressive gases should not be present in the ambient air.

Caution

If storage conditions are inappropriate there is a risk of bearing seizure damage.

Preservation (mothballing)

If motors are to be put into storage for longer than 6 months, then they must be checked every 6 months to ensure they are in good working order and any necessary maintenance work must also be carried out. Document all preservation measures taken, so that they can be reversed before the motors are put back into service. Slightly heat the windings of motors constantly and ensure good air circulation.

Caution

If the motors were supplied with a shipping brace, secure the rotor in accordance with the instructions for the shipping brace in order to prevent vibration damage to the bearings.

If the motors are equipped with condensation drain holes, remove the screw plugs at regular intervals, let the condensation water drain off and refit the plugs.



Caution (Environmental Protection)

Disposal of packing material: On unpacking the motors, the packing material shall be disposed as per the Local / Statutory requirements. Special attention should be given to Polythene bags, thermocole packing and nylon straps etc., which are not biodegradable.

3.2 Installation

Instructions relevant for safety

- After installation, screwed-in lifting eyebolt(s) should either be removed or tightened down.
- Remove rotor locator (when provided) from shaft extension. Check the free running of the rotor by rotating the shaft by hand.
- The shaft extension of the motor is coated with an anticorrosion agent. To remove this coating use kerosene / thinner. Do not use sandpaper or scraper.
- Before mounting the motor, see that the motor feet are properly cleaned.
- As a standard practice, the transmission elements to be fitted to the motor should be dynamically balanced. Please note that the rotors of the motors are dynamically balanced with half key inserted in the shaft extension of the motor.
- Transmission elements must be fitted and removed only by means of suitable tool.
- Install the motor in such a manner that the cooling air has free access and can escape unobstructed. Discharged air or hot air from neighboring equipment, must not be sucked in again. Clean the entire path of air over the motor (between ribs and air inlet in fan cowl) at regular intervals to remove any foreign deposits, preferably by means of compressed air.
- Motors are provided with plugged drain-holes, located at lowermost point on both the end shields for drainage of condensate water. Please ensure that these holes are the lowest point of the motor. If necessary rotate the end shield.
- For foot mounted motors to be fixed on the wall a support should be provided for the mounting feet from below.
- In the **case of motors with shaft end facing upwards or downwards**, measures must be taken (by the user) to ensure that no water or dust can penetrate into the upper bearing.
- Initial lubrication of the bearings is carried out in works. Bearings must be regreased when the motor is running.
- If the belt drive is used, install the machine in such a manner that it can be shifted on its base (e.g. on slide rails) to obtain correct belt tension. Excessive belt tension may result in damage to the bearing and/or shaft. For permissible radial loads on shaft extension and recommended pulley sizes refer the Siemens catalog or contact local Siemens office.



Caution

Excessive belt tension may result in damage to the shaft bearings; for permissible values, see catalog or enquire.

Quiet running

Stable foundations or mounting conditions, exact alignment of the motors and a well-balanced transmission element are essential for quiet vibration-free running. If necessary, shims should be inserted under the motor feet to prevent strain.

Caution

When routing cables or other parts or components close to or next to the motor frame, it should be taken into account that the motor frame could be at a high temperature during operation.

Take careful note of the technical data specified in the motor documentation and on the plates on the motor frame! The following conditions must also be observed:

Shipping brace

If any shipping braces are in place, remove them before installation.

Cooling

The cooling air must be able to be drawn-in and discharged unimpeded; ensure that warm discharged air is not drawn back in at the air intake. On the vertical motor design with air intake from above, the air inlets must be protected against the ingress of foreign bodies and water, preferably by using a protective Canopy.

Balancing quality

The rotors are dynamically balanced. For shaft ends with keys, a half key is inserted into the motor shaft for maintaining balancing quality.

Please make sure that the power take-off element is correctly balanced e.g. half-coupling, pulley, etc. Power take-off element may only be fitted or removed using suitable equipment.

Balancing, transmission elements

A suitable device should always be used for fitting and removing the transmission elements (coupling halves, pulleys, pinions).

As standard, the rotors are dynamically balanced with the half key inserted.

When fitting the transmission element, keep the type of balance in mind! Balance with half key.



Warning

The usual measures should be taken to guard transmission elements from touch. If a motor is started up without transmission element attached, the key should be secured to prevent it being thrown out.

Due attention should be given to the measures necessary to prevent accidental touching of rotating parts (couplings, pulleys, etc.).



Caution

The keys are only secured against falling-out during transport. If the motor has two shaft ends, and a power take-off element is only fitted to one end, steps must be taken to prevent the key at the other end from being slung out.

Noise emission

When assessing the noise that is emitted at a workplace (if any), it should be taken into account that the A-weighted sound pressure level, (measured in accordance with IS: 12065: "Permissible limits of noise level for rotating electrical machines"), may be higher when the three-phase AC motors are operated with the rated output.

Water drain holes

In the bearing end shields on the drive end and non-drive end, water drain holes are situated in the foot area and opposite the regreasing devices. They are sealed with plastic plugs. If there is a risk of condensation forming in the motor (e.g. due to severe fluctuations in ambient temperature or direct sunlight), it may be useful to remove the plugs located at the bottom after installation.

Note

Nominally the degree of protection of the motor is reduced to IP44 by removal of the plug.

Rolling-contact bearings

The permissible values for axial and radial forces are to be taken from the catalog, or inquiries should be made as necessary.

Installation surfaces

Make sure that the surfaces for the foundations are leveled and that the installation surfaces for the motor are parallel to the surface of the foundations. The undersides of the feet of the machine must be cleaned before installation.

3.3 Aligning

Instructions relevant for safety

Detailed specialist know-how is required about the necessary measures in order to correctly align and securely mount the equipment, e.g. for

- Preparing the foundation,
- Selecting and mounting the coupling,
- Measuring the concentricity and axial eccentricity tolerances,
- Axial and horizontal positioning.

If personnel are not familiar with the necessary measures and working steps, we recommend that the services of the local SIEMENS service center be used.

Vertical and horizontal position

The following measures are required in order to compensate any radial offset at the coupling and to horizontally adjust the electric motor with respect to the driven load:

Place shims under the motor feet to position it vertically and to avoid stressing/distorting the machines. The number of shims should be kept as low as possible i.e. stack as few as possible.

To horizontally position the machine, push it laterally on the foundation and ensure that the axial position is maintained.

When positioning the motor, ensure that there is a uniform axial gap around the coupling.

3.4 Mounting

Overview

In order to ensure smooth, vibration-free motor operation, a stable foundation design is required, the motor must be precisely aligned, and the components, which are to be mounted on the shaft end, must be correctly balanced.

Notice

Please refer IS: 12075: Mechanical vibration of rotating electrical machines with shaft heights 56mm and higher – Measurement, Evaluation and Limits of Vibration severity.

Note

Motors that are attached by their mounting feet to the wall (IMV5 or IMV6 construction) must be supported by a wall strip.

Where belt drive is used it is of advantage to use sliding rails to mount the motor so as to be able to set the correct belt tension.

3.5 Connecting the grounding (earthing) conductor

Connection to the motor

The motor earth conductor cross-section must be compliant with the installation and erection regulations, for example in accordance with IS: 3043 for cross-sections greater than 35 mm² of the phase conductor, with a minimum of 50% of the cross-section of the phase conductor.

There is a hexagon bolt with flat and spring washer on the stator frame at the designated connecting point for the earthing conductor. This is suitable to connect multi-core conductors with cable lugs or straps with appropriate conductor ends.

Connection in the terminal box

In the terminal box, the labeled connection terminals for the grounding conductor should be used.

For detailed information on connecting the external & internal grounding conductors please refer "Annexure-2" (Page 30).

Caution

The bearings and shaft can be damaged if the belt tension is too high. It is essential, therefore, that you adhere to the permissible values.

Use machine fixing bolts with the necessary strength class to IS: 1367-Part 3 (ISO 898-1) (e.g. 10.9) for reliable mounting and safe transmission of forces resulting from torque. When selecting the bolts and the design of the foundation you must take into account the maximum forces occurring in the case of a fault (e.g. short circuit or system transfers in phase opposition).

3.6 Connection of the motor

Overview



All work on the motor must only be performed by qualified personnel, with the motor in a stationary state. The supply should be secured so that it cannot be switched back on again. Check that no voltage is present before commencing work.

The type designation of the terminal box for connecting the power cables can be found in the section entitled "Technical data"; refer to the spare parts list entitled "Main terminal box" for a diagram of the terminal box. Connecting cables can be sealed and secured at every entry point into the terminal box. Suitable entry plates can be rotated through 180°.

The necessary connection data regarding

- The direction of rotation,
- The number and arrangement of the terminal boxes,
- The circuit and connection of the motor winding are specified in the section entitled "Technical data".

The permissible direction of rotation can also be seen on the motor rating plate.

Examine the rating plate data and ensure that it matches with the power circuit to which the motor is to be connected. Check to see that system voltage and frequency agree with the data given on the rating plate. Select the size of supply cables as required for the particular current rating. Connect the supply cables in accordance with the connection diagram shown inside the terminal box cover.

Connection and arrangement of the terminal links must agree with the diagram provided in the terminal box.

Before closing the terminal box ensure that:

- Interior of the terminal box is clean and free of cable residue.
- All terminal screws and bolts are firmly tightened.
- Minimum air-clearance (>10mm upto 500V. >14mm upto 1000V) is maintained.
- Unused cable entries are sealed off with the plugging elements firmly screwed in.
- All sealing surfaces have adequate contact.

When the motors are provided with anti-condensation heaters, ensure that the supply to heaters is switched off before switching on the motor.

Before starting and during operation, make sure that all the relevant safety and statutory regulations pertaining to the area of operation are complied with.

Earthing

Connect the earthing conductor to the terminal with the earthing marking in Terminal box as well as on the Stator housing.

Clean area underneath the earthing terminal and smear it with petroleum jelly before making earthing connections. For motor driven with VFD, earthing instructions as given in the VFD manual must be followed strictly.

For detailed information on operation of motor with converter, please refer Annexure-3 (Page31).

Checking the insulation resistance

The insulation resistance of the windings must be measured prior to initial startup of the machine, and after long periods of storage or standstill (approximately 6 months).



While the measurement is being taken and immediately afterwards, some of the terminals carry dangerous voltages and must not be touched.

Measurement

The insulation resistance of the windings to ground is measured with 500V DC. The winding temperature should be 30°C±15°C.

Checking

Minimum insulation resistance value (at 40°C) as specified in IS: 4722 is $R_m = kV + 1$, where kV is the rated voltage of the machine. Thus, for 415V rated voltage the insulation resistance of the winding should not be less than 1.42 MOhm.

If less the winding must be suitably dried as per IS: 900

Connecting

Note

Ensure that there is a safe and reliable PE ground connection before starting any work.

The connection must be made in such a way that a permanent, safe electrical connection is maintained (no protruding wire ends). Use the matching cable end pieces. Depending on the parts fitted, the connecting parts may be suitable for connection with or without cable lugs.

In some cases a terminal strip is installed in the main terminal box for the auxiliary circuit connections. The connecting terminals of the auxiliary circuits are suitable for cable cross-sections of up to 1.5 mm² (fine-wire) or 2.5 mm² (single-wire). On conductors for auxiliary terminals, the length of insulation, which needs to be stripped, is approximately 6 to 9 mm depending on the terminal type. When this length is correct the conductor reaches right into the terminal as far as it can go while the wire insulation reaches the contact part of the terminal.

Direction of rotation

Connection of the power cables in the phase sequence L1, L2, L3 to U, V, W results in a clockwise rotation. If two of the connections are swapped then the resulting direction of rotation is counter-clockwise (e.g. L1, L2, L3 to V, U, W). On motors, which are only allowed to run in one direction, the rating plate shows an arrow, which indicates the permitted direction of rotation, and it also specifies the terminal connections for the required phase sequence.



Direction of rotation of the motor when looking at the drive end

Note

These restrictions in terms of the direction of rotation relate to the particular type of motor design and result, for example, from the use of unidirectional fans. Any restrictions in terms of the direction of rotation resulting from the installation itself are not shown in the information on the rating plate and need to be considered separately when making the connections.

Connecting using cable lugs

When using cable lugs to make the connection, the choice of cable lug size must match the required conductor cross-section and the bolt size. A sloped/ angular arrangement is only permitted provided the required air insulation gaps are met. Remove the insulation from the conductor ends, so that the remaining insulation is almost long enough to reach the cable lug.

Note

The current-carrying capacity of the connection is guaranteed using the CuZn contact nuts. These nuts must not be replaced with parts manufactured from different materials.

Connection without cable lugs

The design of the terminals makes it possible to connect fine-wire conductors without the use of wire end ferrules. Wire end ferrules may only be used, if these are attached, before connecting-up, using the correct, current-carrying compression technique.

Notice

If the terminal link is used, the current-carrying connection is guaranteed using CuZn contact nuts. These nuts must not be replaced with parts manufactured from different materials.

Aluminum conductors

If aluminum conductors are connected, we recommend removing the oxide coating layer using a brush or file prior to inserting them in the clamps. The

conductors should then be immediately greased using neutral Vaseline in order to prevent reoxidation.

Notice

Aluminum flow is likely to occur after the conductors have been connected due to the contact pressure. This should be compensated for by re-tightening the clamping nuts after approximately 24 hours and then again after approximately 4 weeks.

Use of single-stranded cables

If high currents occur when using several single-stranded cables instead of multiple-stranded cables for three-phase supply cables, high temperatures can be generated at the materials around the entry points to the terminal box as a result of eddy currents. Once the system has been taken into operation it is therefore necessary to check that the temperature limits of the connected power cables are not exceeded in operation.

This temperature effect can be reduced by altering the conditions at the entry points or by using modified cable entry plates after consultation with the manufacturing plant.

Cable entry and routing

Connecting cables and in particular the PE ground conductor in the terminal box should be laid out in an open arrangement, and they should preferably have spare length to prevent chafing of the cable insulation.

Auxiliary cables fed in externally must be routed separately from the main cable and secured. Elements with cable ties are located on the floor of the terminal box next to the walls for this purpose.

Screw-type cable connections should normally be used (not included in the delivery scope). In special cases the connecting cable is sealed at the cable entry point using a cutout seal insert and is fastened using a strain relief device. The strain relief device can either be located in the terminal box or externally.

We recommend the following procedure:

- Cut out the seal insert in such a way that its opening is 1 to 3 mm smaller than the cable diameter. If the cable diameter is too small, this should be increased by applying a layer of suitable sealing tape around the conductor.
- After inserting the seal, make a termination to match the cable and connect an earthing cable to it. If the cable has external armoring, do not route it directly into the terminal box, but just up to the strain relief device, which in this case should also be fitted externally. This prevents moisture from penetrating into the terminal box.
- Unscrew the upper section of the tension relief device and release the mounting screws for the lower section. Insert the cable with seal insert into the gland opening. When the cable is positioned concentrically inside the gland opening, screw the tension relief clamp together and appropriately retain it.

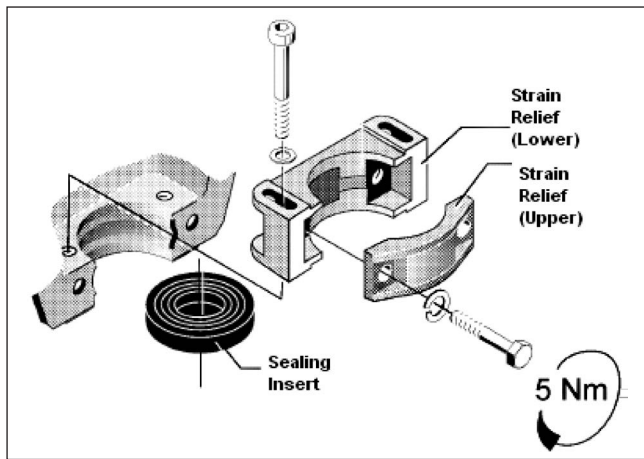

Cable grip and sealing insert

Note

Tighten the strain relief clamp screws; so that the required clamping effect is achieved without damaging the cable insulation, a tightening torque of 5 Nm is recommended (see Fig.).

Internal PE ground conductor connection

The PE ground conductor connection between the grounding terminal in the box enclosure and the motor enclosure is made by means of the mounting screws of the terminal box. The standard terminal box cover mounting screws are adequate as potential bonding between the terminal box cover and terminal box itself.

The equipotential bonding between the terminal box cover and the box enclosure is provided by means of the standard cover mounting screws. A special external ground cable is only installed if, for example, flat seals are mounted without additional support. When performing any installation work you must always take care to ensure that all equipotential bonding measures remain effective.

Final checks

Please check that:

- The electrical connections in the terminal box have been made in accordance with the specifications above and tightened to the required tightening torque.
- The air gaps between non-insulated parts are maintained:
 ≥ 8 mm up to 500 V, ≥ 10 mm up to 660 V and ≥ 14 mm up to 1000 V.
 Be aware of protruding wire ends when checking this.
- The connecting cables are laid in an open arrangement, so that the cable insulation cannot be damaged during operation.
- The motor is connected-up corresponding to the specified direction of rotation.
- The inside of the terminal box is clean and free of any cable pieces.

- All gaskets and seals are undamaged.
- Unused openings in the terminal boxes are properly closed off.

Then close the terminal box and tighten the terminal box cover screws to 22 Nm.

3.7 Connection to the converter

Temperature sensor

Whenever motors are labeled for operation with a converter, they are usually equipped with an upgraded set of temperature sensors. This is because of the reduced effectiveness of the fan at lower speed ranges and the low temperature limits.

3.8 Converter operation on a grounded network

Parallel PE conductors

In the case of current-limited converters without ground fault monitoring, PE conductor currents of up to 1.7 times the external conductor current can arise if there is a ground fault on the output side. Neither the PE conductors of normally rated multi-core connecting cables nor the PE connecting points of normal terminal boxes are suitable for this purpose. In these cases a sufficiently dimensioned parallel PE conductor needs to be installed. This can then be connected to the ground terminal positioned on the motor enclosure.

4 Commissioning

4.1 Preparations

Safety instruction



Warning

Only expert persons should be entrusted with work on power installations. All covers which are designed to prevent active or rotating parts from being touched, or which are necessary to ensure correct air guidance and thus effective cooling, must be installed prior to commissioning.

Commissioning

Note

Where the torque is very uneven (the drive of a reciprocating type compressor, for example), the inevitable result is a non-sinusoidal motor current, whose harmonics can lead to excessive system perturbation or excessive electromagnetic interference.

In case of converter-fed motors, high-frequency current or voltage harmonics in the motor cables can give rise to electromagnetic interference. This is why the use of shielded cables is recommended.

Checking the insulation resistance

Caution

The insulation resistance needs to be checked prior to commissioning and again after any extended periods of storage or periods during which the equipment is not in operation. Before you begin measuring the insulation resistance, please read the manual of the insulation resistance meter you are going to use. Any cables of the main circuit, which are already connected should be disconnected from the terminals in order to carry out the insulation measurements.



Warning

During the measurement and immediately afterwards, some of the terminals are at hazardous voltage levels and must not be touched.

Preferably measure the insulation resistance of the winding with reference to the motor enclosure when the winding temperature is between 20 and 45°C. When making the measurement, you must wait until the final resistance value is reached (approx. 1 minute).

Limit values

The table below shows the measuring voltage and the threshold values for minimum insulation resistance and critical insulation resistance.

Insulation resistance

	Rated voltage $U_N < 2 \text{ kV}$
Measuring-circuit voltage	500 V DC
Minimum insulation resistance with new, cleaned or repaired windings	5 MΩ
Critical specific insulation resistance after a long operating time	0.5 MΩ/kV

(values apply at a winding temperature of 35°C)

Note the following points:

- If the measurements are performed when the coil temperature is not at 35°C, the measured value will need to be converted to the reference temperature of 35°C in order to be able to compare the values with the table above. The insulation resistance is reduced by a factor of a half for every 10K increase in temperature, and it is increased by a factor of two for every 10K decrease in temperature.
- Dry, new windings have insulation resistances of between 100 and 2000 MΩ, or possibly even higher values. If the insulation resistance is close to the minimum value, then the cause could either be humidity and/or dirt accumulation.
- Over its operating lifetime, the motor winding insulation resistance can drop due to ambient and operational influences. The critical insulation resistance for a 35°C winding temperature can be calculated, depending on the rated voltage, by multiplying the rated voltage (kV) by the specific critical resistance value (0.5 MΩ/kV); e.g. critical resistance for a rated voltage (UN) of 690 V:
 $690 \text{ V} \times 0.5 \text{ M}\Omega/\text{kV} = 0.345 \text{ M}\Omega$

Notice

If the critical insulation resistance is reached or undershot, the windings must be dried or, if the fan is removed, cleaned thoroughly and dried. After drying a cleaned winding, please note that the insulation resistance is lower for windings in the warm condition. The insulation resistance can only be properly assessed after conversion to the reference temperature of 35°C.

Notice

If the measured value is close to the critical value, the insulation resistance should be subsequently checked at appropriately shorter intervals.

4.2 Measures to be taken prior to commissioning

Overview

After assembling the motor in line with technical requirements and before commissioning the system, check that:

- The motor has been assembled and aligned properly.
- The motor is connected up corresponding to the specified direction of rotation.
- The operating conditions are in accordance with the data specified on the nameplate.
- The bearings have been regreased (depending on the version). Rolling-contact bearing motors which have been in storage for more than 2 years must be regreased.
- Any supplementary motor monitoring devices and equipment have been correctly connected and are functioning.
- Appropriately configured control functions and speed monitoring equipment ensure that speeds higher than the permissible speeds stated on the rating plate do not arise.
- The power take-off elements have the correct parameters for their type (e.g. alignment and balancing of couplings, belt tension of a belt drive, backlash and crest clearance of a gear PTO drive, radial clearance).
- The minimum insulation resistance values and the minimum air gap values are satisfied.
- The earthing and equipotential grounding connections have been correctly made.
- Any bearing insulation, which may be present, has not been bridged.
- All retaining bolts, connecting elements and electrical connections have been tightened to the specified torque.
- The rotor can be spun without coming into contact with the stator.
- All shock-protection and guard measures for moving and live parts have been taken.
- If the second end of the shaft is unused, its key has been secured so that it cannot be thrown out and the open shaft end is covered.
- All separately driven fans fitted are ready for operation and have been connected such that they rotate in the direction specified.
- The flow of cooling air is not impeded.
- Brakes (if fitted) function perfectly.
- The indicated speed limit n_{max} cannot be exceeded during operation with a converter.

Note

The maximum speed n_{max} is the highest operating speed permitted for short periods. It should be kept in mind that motor noise and vibration are worse at this speed, and bearing life is reduced. (For details refer catalogue or contact nearest Siemens office).



Caution

After motor installation, the brake, if fitted, should be checked for proper functioning.

If the design of the motor requires that the converter is assigned in a particular way, the rating plate will contain corresponding additional information.



Warning

This list does not claim to be exhaustive. It may be necessary to make additional checks and tests corresponding to the actual plant/system situation.

4.3 Monitoring the temperature of the stator winding

Measures

In addition to the current-dependent overload protection device located in the connecting leads, we recommend that you also monitor the temperature rise in the motor with the aid of the temperature sensors embedded in the stator winding.

4.4 Energizing

Measures during commissioning

The following measures are normally recommended after installation or inspection work for standard commissioning of the motors:

- Start up the motor without a load; to do this, close the power switch and preferably do not switch it off prematurely. Switching the motor back off again while it is starting up and still running at slow speed should be kept to a bare minimum, for example for checking the direction of rotation or for checking the operation of the motor. Allow the machine to run to a standstill before switching it back on again.
- Check the mechanical operation for noises and vibrations at the bearings and bearing end shields.
- If the motor does not run smoothly and/or there are any abnormal noises, switch it off and determine the cause as it slows down.

- If the mechanical operation improves immediately after switching the motor off, then the cause is magnetic or electrical. If the mechanical operation does not improve immediately after switching the motor off, then the cause is mechanical: e.g. an imbalance in the electrical machines or in the driven machine, inadequate alignment of the machine set, operation of the machine with the system resonating (system = motor, base frame, foundation etc.).
- If the motor runs perfectly in terms of its mechanical operation, switch on any present cooling devices (separate fan, water cooler or similar) and continue to monitor the motor for a while as it idles.
- If it runs perfectly connect a load. Check that it runs smoothly, and record the values for voltage, current and power. As far as possible, record the corresponding values for the working machine as well.



Warning

The vibration values encountered during operation must be satisfied in accordance with IS: 12075: Mechanical vibration of rotating electrical machines with shaft heights 56mm and higher – Measurement, Evaluation and Limits of Vibration severity, as otherwise the motor could be damaged.

- Monitor and document the temperatures of the bearings, windings etc. until the system reaches a steady state, in as much as this is possible with the available measuring equipment.

4.5 De-energizing

Measures during de-energizing

Anti condensation heaters if present should be switched on automatically when the motor is de-energized.

If the corresponding control action does not take place automatically, switch on the anti-condensation heating if present.

5 Operation

5.1 Safety information

Energizing the motor with anti-condensation heating (optional)



Caution

Before energizing the motor, always make sure that the (optional) anti condensation heating is switched off.

Operating machines



Warning

All covers which are designed to prevent active or rotating parts from being touched, or which are necessary to ensure correct air guidance and thus effective cooling, must not be opened during operation.

All deviations from normal operation (higher power consumption, temperature or vibration level, unusual noises or odors, tripped monitoring devices, etc.) are indications that the motor is no longer functioning correctly. In this case, the maintenance technician must be immediately notified in order to prevent disturbances that could either directly or indirectly lead to severe personal injury or substantial material damage. If in doubt, power-down the motor immediately in conformance with the system-specific safety requirements!



Caution

The surfaces of the machines can reach high temperatures, which can lead to burns in case of contact. That is why appropriate measures to avoid accidental contact must be taken.

Cleaning

To ensure proper functioning of the machine cooling system, the air ducts (grills, ducts, ribs, pipes) must be free of pollution / blockages.

Caution

During machine operation, humid air can condense inside the machine. Depending on the environmental and operating conditions, therefore remove the condensation water plug to drain the water. Afterwards, reinsert the plug.

5.2 Stoppages

Overview

For longer periods where the motor is not being used (> 1 month), either energize the motor regularly, approximately once a month, or at least spin the rotor. Read the instructions given in the "Start-up, Energizing" section before restoring the machine to service. If a rotor-locking device has been fitted to the motor, you must remove it before you spin the rotor.

Caution

If the motor is not to be used for a period in excess of 12 months, suitable anticorrosion, preservation, packaging and drying measures must be taken.

Switching on the anti-condensation heating

If an anti-condensation heating is provided, switch it on during the machine stoppages.

Placing the machine out of service

For details of required measures see "Transport, Storage" section.

Lubrication prior to recommissioning

Caution

If the motor has not been used for longer than 12 months, it must be regreased before being restarted. The shaft must rotate so that the new grease can be distributed throughout the bearings.

Pay attention to the instructions on the lubrication plate.

5.3 Fault diagnosis table

Overview

Note

In the event that electrical faults occur during the operation of the motor with a converter, please also refer to the operating instructions of the frequency converter.

The tables below list general faults caused by mechanical and electrical influences.

Electrical faults

Fault table, electrical causes

Overview - Electrical faults								
							Electrical fault characteristics	
↓							Motor will not start up	
↓							Motor starts up slowly	
↓							Drumming noise during startup	
↓							Drumming noise during operation	
↓							Drumming noise in time with twice the slip frequency	
↓							High temperature rise during idling	
↓							High temperature rise under load	
↓							High temperature rise of individual winding sections	
							Possible causes of fault	Remedial measures ¹⁾
x	x		x			x	Overload	Reduce load
x							Interruption of a phase in the supply	Check switches and supply lines
	x	x	x			x	Interruption of a phase in the supply after switching on	Check switches and supply lines
	x						Mains voltage too low, frequency too high	Check mains conditions
					x		Mains voltage too high, frequency too low	Check mains conditions
x	x	x	x			x	Stator winding incorrectly connected	Check winding connections
	x	x	x			x	Winding short circuit or phase short circuit in stator winding	Measure winding resistances and insulation resistances, repair after consultation with manufacturer
				x			Defective soldered connection in short circuit cage	Repair after consultation with manufacturing plant
						x	Incorrect direction of rotation	Check connections

(1) Apart from eliminating the cause of the fault (as described under "Remedial measures"), you must also rectify any damage the motor may have suffered.

Mechanical faults

Fault table, mechanical causes

Overview - Mechanical faults																																																																		
		Mechanical fault characteristics																																																																
	↓	rubbing/grinding noise																																																																
	↓	high temperature rise																																																																
		↓	radial vibrations																																																															
			↓	axial vibrations																																																														
				<table border="1"> <thead> <tr> <th>Possible causes of fault</th> <th>Remedial measures¹⁾</th> </tr> </thead> <tbody> <tr> <td>x</td> <td>Rotating parts rubbing/grinding</td> <td>Determine cause and adjust parts</td> </tr> <tr> <td></td> <td>x</td> <td>Reduced air supply, fan possible running in the incorrect direction of rotation</td> <td>Check airways, clean motor</td> </tr> <tr> <td></td> <td></td> <td>x</td> <td>Rotor not balanced</td> <td>Decouple rotor and rebalance</td> </tr> <tr> <td></td> <td></td> <td></td> <td>x</td> <td>Rotor out of true, shaft bent</td> <td>Consult Siemens</td> </tr> <tr> <td></td> <td></td> <td></td> <td>x</td> <td>x</td> <td>Poor alignment</td> <td>Align motor unit, check coupling²⁾</td> </tr> <tr> <td></td> <td></td> <td></td> <td>x</td> <td></td> <td>Coupled motor not balanced</td> <td>Rebalance motor coupled up</td> </tr> <tr> <td></td> <td></td> <td></td> <td></td> <td>x</td> <td>Shocks from coupled motor</td> <td>Check motor coupled up</td> </tr> <tr> <td></td> <td></td> <td></td> <td>x</td> <td>x</td> <td>Imbalance originating from gearing</td> <td>Adjust/repair gearing</td> </tr> <tr> <td></td> <td></td> <td></td> <td>x</td> <td>x</td> <td>Resonance of the overall system comprising motor and foundation</td> <td>After consultation, reinforce foundation</td> </tr> <tr> <td></td> <td></td> <td></td> <td>x</td> <td>x</td> <td>Changes in foundation</td> <td>Determine cause of changes and eliminate; realign motor</td> </tr> </tbody> </table>	Possible causes of fault	Remedial measures ¹⁾	x	Rotating parts rubbing/grinding	Determine cause and adjust parts		x	Reduced air supply, fan possible running in the incorrect direction of rotation	Check airways, clean motor			x	Rotor not balanced	Decouple rotor and rebalance				x	Rotor out of true, shaft bent	Consult Siemens				x	x	Poor alignment	Align motor unit, check coupling ²⁾				x		Coupled motor not balanced	Rebalance motor coupled up					x	Shocks from coupled motor	Check motor coupled up				x	x	Imbalance originating from gearing	Adjust/repair gearing				x	x	Resonance of the overall system comprising motor and foundation	After consultation, reinforce foundation				x	x	Changes in foundation	Determine cause of changes and eliminate; realign motor
Possible causes of fault	Remedial measures ¹⁾																																																																	
x	Rotating parts rubbing/grinding	Determine cause and adjust parts																																																																
	x	Reduced air supply, fan possible running in the incorrect direction of rotation	Check airways, clean motor																																																															
		x	Rotor not balanced	Decouple rotor and rebalance																																																														
			x	Rotor out of true, shaft bent	Consult Siemens																																																													
			x	x	Poor alignment	Align motor unit, check coupling ²⁾																																																												
			x		Coupled motor not balanced	Rebalance motor coupled up																																																												
				x	Shocks from coupled motor	Check motor coupled up																																																												
			x	x	Imbalance originating from gearing	Adjust/repair gearing																																																												
			x	x	Resonance of the overall system comprising motor and foundation	After consultation, reinforce foundation																																																												
			x	x	Changes in foundation	Determine cause of changes and eliminate; realign motor																																																												

(1) Apart from elimination the cause of the fault (as described under "Remedial measures"), you must also rectify any damage the motor may have suffered.

(2) Take any possible changes due to a rise in temperature into account.

6 Maintenance

6.1 Maintenance

6.1.1 Preparations for maintenance

Instructions relevant for safety



Warning

Before starting any work on the motor or other equipment, particularly before opening covers over live or moving parts, the motor must be properly isolated from the power supply. Besides the main circuits, any additional or auxiliary circuits that may be present must also be isolated especially the anti-condensation heating.

The "5 Safety rules" to be followed are:

- Isolate the equipment
- Take effective measures to prevent reconnection
- Verify equipment is dead
- Ensure proper earthing connections
- Cover or fence off adjacent live parts

The precautions listed above should remain in force until all maintenance work is finished and the motor has been fully assembled.

Certain parts of the motor may reach temperatures above 50°C.

When cleaning the motor with compressed air, ensure that suitable exhaustion measures are used and you use personal protective gear (goggles, face mask/filter or similar)!

If chemical cleaning agents are used, observe the instructions and any warnings.

Chemical agents must be compatible with the motor's components/parts, especially when it involves plastics.



Caution

(Environmental Protection)

The disposal of waste generated during operation & maintenance of the motor should be done as per the applicable local environmental legislations.



Caution

(Environmental Protection)

Waste Copper windings during repair and maintenance - to be collected as segregated waste and sent to registered recyclers approved by the respective State Pollution Control Board.

Note

Operating conditions and characteristics can vary widely. For this reason, only general maintenance intervals can be specified here.

Note

Where motors are fitted with plugged drain holes, these should be opened from time to time to allow any accumulated condense water to be drained away.

Condense water openings should always be at the lowest point of the motor!

General

Periodic overhauling of the motor is recommended to ensure long trouble free service.

Before starting the maintenance work, make sure that the supply is disconnected. These motors are provided closely pitched ribs for effective cooling of the motor. These ribs should be cleaned at regular intervals either by oil free compressed air, or by scraping, depending on the level of contamination.

The inside of the motor should be cleaned using dry compressed air during normal overhauling of the motor. Special care should be taken while cleaning the windings to remove loose dust, moisture etc.

6.1.2 Bearings

Bearing and lubrication

All motors, as a standard feature, are provided with floating bearing at Non-drive end and fixed bearing at Drive end. All motors are provided with regreasing arrangement (grease nipples).

Grease types

The regreasing intervals and the grease types are stated on the lubrication instruction plate of the motor. The motor must be regreased at least once every 12 months. The greasing instructions can be found on the lubrication instruction plate.

For standard applications, the initial greasing of the bearings is usually done with a grease suitable for temperature range from -20°C to 130°C. If the motors have been ordered for the extended operating temperature range below -20°C or above 130°C, the permissible grease type is specified on the lubrication data plate.

Unirex N3 of Exxon Mobil is the grease used in Siemens motors. This grease has Lithium soap as thickening agent and mineral oil as the basic oil.

Caution

Greases with different thickening agents and basic oils must not be mixed.

Only in special cases should deviations be made from the usual greasing data. The regreasing intervals should be shortened for instance, if the motors are operated at ambient air temperatures higher than originally allowed for, or if corrosive vapours occur or extremely heavy contamination is present.

To relubricate, clean the grease nipple and inject suitable grease stipulated on the lubrication data plate using a grease gun. The shaft must rotate so that the new grease can be distributed throughout the bearing. The bearing temperature rises sharply at first, and then drops to the normal value again when the excess grease is displaced out of the bearing. The spent grease collects outside the bearing and must be removed after the bearing has been lubricated several times, depending on the specified regreasing intervals. The outer bearing cover must be removed in order to do so. Escaping oil at the bearing or oil escaping during regreasing is an indicator that the space for the spent grease has been over-filled.

Remove the old grease while overhauling the machine.



Caution

(Environmental Protection)

Waste grease & Greased cloth - to be collected as hazardous waste and sent to hazardous waste disposal facility for incineration.

Note

Motors provided with cylindrical roller bearings on the drive end sides have very high dynamic capacity. As per bearing manufacturers, the roller bearing performs satisfactorily only when it is radially loaded to approximately 1-2% of its dynamic capacity. In view of this, the roller bearing may not run smooth when the motor is run uncoupled or with low radial load (e.g. In direct flexible couplings).

6.1.3 Regreasing with sealing grease (option for increased degree of protection)

Relubricating with sealing grease

In order to achieve optimum sealing and to reliably seal the labyrinth joints with grease, the chamber must be relubricated at regular intervals. The procedure is the same as that for lubricating grease. The necessary relubrication intervals depend essentially on the level

of dirt in the environment and on the ON time of the motor.

For this reason, they can only be defined taking into account the respective operating conditions.

The sealing effect during operation is optimum as long as a small amount of relatively clean grease is forced out. At the very latest, the chamber must be relubricated when no more grease escapes through the joints. The relubrication intervals during stoppages can be extended accordingly as long as the sealing grease forced out during relubrication is relatively free of dirt.

6.2 Servicing

6.2.1 Servicing instructions

Faults

An inspection should be performed immediately in the event of faults or exceptional operating conditions which represent an excessive load (either electrically or mechanically) for the motor (e.g. overload, short circuit).

Instructions for inspecting rolling-contact bearings

When servicing a motor, it is generally not necessary to dismantle it. The first time a motor needs to be dismantled is when the bearings are to be replaced.

Caution

The required regreasing intervals for rolling-contact bearings are not the same as the servicing intervals. It is essential to adhere to them.

Caution

The spent-grease chambers of the rolling-contact bearings only have enough room to take up a limited amount of spent grease. When the grease chamber is full, you must remove the spent grease before relubricating, because it will otherwise escape into the inside of the motor. Escaping oil at the bearing or oil escaping during regreasing is an indicator that the space for the spent grease is full.

6.2.2 First service after installation or repair

Service criteria

After approximately 500 operating hours, at the latest after 1 year

- Check, while the motor is running, that:
 - The equipment conforms to the stated electrical characteristics.

- The permissible bearing temperatures are not exceeded.
- The smooth running characteristics and motor noise in operation have not deteriorated.
- Check, while the motor is at standstill, that:
 - The motor foundation has no indentations or cracks.

Further checks may be required in addition as a result of additional operating instructions or in accordance with the plant-specific conditions. Any impermissible discrepancies or changes found during the checks must be rectified immediately.

6.2.3 Main service

Service criteria

After approximately 16 000 operating hours, at the latest after 2 years

- Check, while the motor is running, that:
 - The equipment conforms to the stated electrical characteristics.
 - The permissible bearing temperatures are not exceeded.
 - The smooth running characteristics and motor noise in operation have not deteriorated.
- Check, while the motor is at standstill, that:
 - The motor foundation has no indentations or cracks.
 - The motor is aligned within the permissible tolerance ranges.
 - All of the mounting bolts for the mechanical and electrical connections are tight.
 - The winding insulation resistances are sufficiently high.
 - If the bearings are insulated, the insulation has not been bridged.
 - Cables and insulating parts and components are in a good condition and are not discolored.

6.3 Repair

6.3.1 Preparations for overhauling / repairs

Instruction relevant for safety

Note

If the motor has to be transported, please observe the information and instructions in the section entitled "Transport, storage".



Caution (Environmental Protection)

Waste Copper windings during repair and maintenance - to be collected as segregated waste and sent to registered recyclers approved by the respective State Pollution Control Board.

Waste insulation material is a hazardous waste and it should only be incinerated at an authorized agency and not disposed by any other means.

6.3.2 Dismantling

Overview

The drawings and part lists do not include any detailed data about the type and dimensions of the fixing elements, etc.; thus, when you dismantle the motor, you should make a note of where the parts belong and mark them so that they can be easily re-assembled.

Use pullers or suitable devices to disassemble parts and components attached to the motor shaft. Before you pull-off screwed parts and components, replace two of the fixing screws in the top of the parts to be removed by long bolts or stud bolts, so that the parts are still supported after they have been removed.

6.3.3 Dismantling instructions

Pressing on and pulling off drive elements

Use the tapped hole provided in the end of the shaft for fitting drive components such as couplings, gearwheels, belt pulleys etc. and, if possible, heat the components as necessary. Use a suitable puller tool for removing the components. Do not strike the components, e.g. with a hammer or similar tool, when fitting or removing them and do not exert more than the maximum value of radial or axial force – according to the catalog – transmitted to the motor bearings through the shaft extension.

Fans

Radial fan impellers of plastic have two integrally molded tongues, which engage with the circumferential groove of the shaft to provide axial fixing. Before pulling the impeller these tongues must be disengaged and provisionally arrested in the raised position, e.g. by means of inserted shim plates. The fan discs each have two openings for the insertion of a pull-off device, which should be applied so as to act on the hub. Always use the appropriate tool for pulling fan impellers. The use of a hammer is not permissible.

Cast iron fans are axial locked with separate circlip. Cast iron fans are best removed by engaging the puller arms on the outer rim of the fan. In case of larger fans, the puller holes provided on the hub can be used.

Rolling-contact bearing unit

It is recommended that the components that comprise the active part of the bearing be marked to ensure correct assembly.

Removal of Bearings

For removing bearings use proper pullers. Reusable bearings, which are non-separable (e.g. Deep groove ball bearing), should be withdrawn by attaching puller arms to the inner ring of the bearing. If it is a must to apply puller arms on the outer ring of the bearing, the bearing should be rotated during withdrawal to avoid damage to the bearing.

Removal of bearings or inner rings which are not to be used is facilitated by heating them with gas or welding torch.

Outer bearing seal

- V-ring with adjacent protecting ring



Dismantling the V-ring and adjacent protecting ring

Do not remove the press-fitted guard ring when dismantling!

Pull off the V-ring and bearing cover / bearing shield from the shaft.

Afterwards press out the adhesively bonded protecting ring using a suitable tool, taking care not to distort it.

6.3.4 Re-assembly

The motor must be assembled in a dust free, dry and clean location.

As the motor conforms to the type of protection IP55, all machined mating surfaces are provided with a thin even coat of bearing grease. Provide a fresh coat of this grease at the time of re-assembly.

Unmatched surfaces are provided with rubber gaskets. At the time of re-assembly, ensure that the gaskets are in good condition. Place the gaskets carefully to achieve the correct sealing. Replace the gaskets with the new ones if the same are damaged.

All fasteners that are used on the exterior of the motor are provided with a coat of bearing grease to prevent ingress of water and dust through tapped holes. Ensure that the same is provided at the time of re-assembly.

Do not interchange location (DE & NDE) of bearing covers, as the spigot dimensions may be different.

A bearing must be replaced if it is damaged. Damage to bearing is often difficult to recognize; in doubtful cases, replace the bearing. Bearings, which have been removed, should be reused only if they show no trace of damage and provided they are thoroughly cleaned beforehand.

For cleaning bearings use proper cleaning agent e.g. White spirit. Wear gloves.



Caution

The cleaned bearing must be free of foreign bodies (fibers from cleaning rags, hair from brushes, etc.)



Caution

(Environmental Protection)

The bearing to be discarded must be thoroughly cleaned from grease and should be intentionally damaged (using weld marks or cutters etc) to avoid reuse.

The removed grease is a hazardous waste and is harmful to environment causing soil pollution and water pollution. It should only be incinerated at an authorized agency and not disposed by any other means.

Sealing

Clean and coat the bare joints between the parts and components (e. g. between frames, end shields and bearing units) with a non-hardening, permanently flexible sealing compound, e.g. Hylomar MQ32 (follow the manufacturer's application and safety instructions!).

Joint sealing

When reassembling machines with degree of protection IP56 (see rating plate), the joint between the motor frame and the end shields are sealed with rubber 'O' rings. It should be ensured that these are not damaged.

Installation of the rolling-contact bearings

Before installing the bearings, ensure that the parts and components, which are located on the shaft inside the bearing, are put in place first. Take great care and pay attention to cleanliness when fitting and assembling the bearings. To fit the rolling-contact bearings, heat them up to about 80°C in oil or air and then press them onto the shaft. Avoid any heavy blows that might damage the bearings. After cooling, grease is to be filled in the bearing spaces completely, in-between the gaps of the rolling elements and in one-third open space, near the bearing, inside the inner bearing cover.

Pack two third of the bearing cavities with grease! The outer bearing cover is kept free of grease to prevent over greasing. The cavities in the outer bearing cover is meant to collect spilled over / excess grease from the bearing assembly.

In case of regreaseable bearings, also fill the grease ducts in the end shield and the inner bearing cover.

6.3.5 Notes on assembling the bearing seal

V-ring with adjacent protecting ring

When assembling ensure that the seating on the bearing cover for the V-ring is not greased, but that the sealing surface is greased.

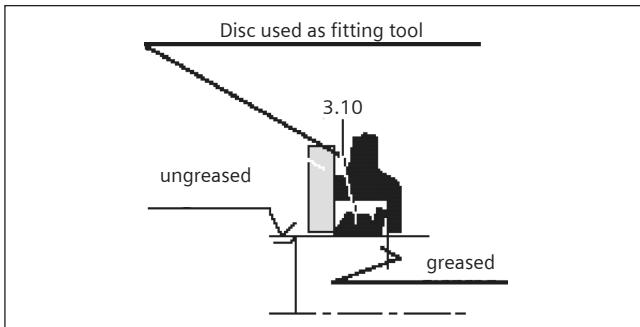

Re-assembly of the V-ring and adjacent protecting ring

The correct axial position of the V-ring has been reached when the front of the bearing cap and the outer corner of the V-ring are flush. The use of a suitable auxiliary disc for assembly purposes is recommended.

To protect the V-ring against mechanical effects in special cases there may be a sheet metal protecting ring fitted in the outer bearing cap. During installation, the protecting ring should be inserted in the centering bore in such a way that one of its two slots coincides with the water drainage slot provided at the low point of its seat in the bearing cap or bearing shield.

6.3.6 Assembling the fan

Fans

Before mounting plastic radial fans on the shaft, make sure that the two integrally molded tongues, which provide axial location in the annular groove, are undamaged.

Fan cowls

The fan cowl is made of sheet steel and welded together. When installing the sheet steel fan cowls, make sure that the retaining components are correctly installed. In the case of unidirectional axial fans also check the radial gap between the fan impeller and the air guide nozzle ($\geq 2\text{mm}$).

6.3.7 Bolt locking devices and tightening torques

Bolt locking devices

Nuts or bolts that are mounted together with locking, resilient and/or force distributing elements must be refitted together with identical, fully functional elements. Always renew positive-action locking elements.

Threads, which are secured with liquid plastic, must be treated accordingly when they are tightened, e.g. using Loctite 243. Fixing bolts with a clamping length greater than 25 mm must be reinstalled using suitable retaining elements or soluble locking compound (e.g. Loctite). The clamping length is taken as the distance between the head of the bolt and the point at which the bolt is screwed in.

Tightening torques

The bolted connections with metal contact surfaces (end shields, bearing cartridge parts, terminal box parts bolted onto the stator frame) should be tightened to the following torques, depending on the thread size.

Tightening torques (tolerance $\pm 10\%$)

	M4	M5	M6	M8	M10	M12	M16	M20	M24	
A	1,2	2,5	4	8	13	20	40	-	-	Nm
B	1,3	2,6	4,5	10	20	34	83	160	280	Nm
C	3	5	8	20	40	70	170	340	600	Nm

The tightening torques in the different rows apply to the following cases:

- Case A applies to electrical connections in which the permissible tightening torque is normally limited by the bolt materials and/or the load-bearing capacity of the insulators (with the exception of the bus bar connections in case B).
- Case B applies to bolts/screws of property class 5.6 (acc. to IS: 1367-Part 3 (ISO 898-1)) or to bolts in components of lower strength (e.g. aluminum).
- Case C applies to bolts/screws of property class 8.8 or A4-70 (acc. to IS: 1367-Part 3 (ISO 898-1)), but only in screwed connections of higher strength components (e.g. gray cast iron, steel or cast steel).

Please refer to the relevant sections and drawings for all other tightening torques (electrical connections and bolted connections for parts with flat gaskets).

6.3.8 Spare Parts

When ordering spare parts, please indicate the correct Motor Type, Serial Number (as shown on the rating plate) and also the correct part description. This will ensure speedy and correct delivery of spare parts. Please refer to the exploded view of the motor.



Caution (Environmental Protection)

Disposal of the product at the end of its life: When it is decided that the product cannot be repaired and is to be disposed off, care should be taken to adhere to Local / Statutory environmental requirements. It should be noted that the product contains grease, copper windings, insulation materials that are not biodegradable and are hazardous to the environment.

For motor

Frame size	Type	1MA8
315 315	
 317	
355 353	
 355	
 357	
400 403	
 405	
 407	

Motor

Part No.	Designation
5.00	Bearing shield at drive end
5.10	Flange bearing shield
6.00	Bearing shield at non-drive end
7.07	Integral fan
8.00	Rotor complete with external fan and rolling-contact bearing
11.04	External fan, unidirectional
11.05	External fan, bidirectional
12.01	Fan cowl
12.70	Protective cover
20.00	Terminal box, complete with terminals

Bearing

Part No.	Designation
3.20	Outer bearing cap on drive end
3.60	Inner bearing cap on drive end
4.20	Outer bearing cap on non-drive end
4.60	Inner bearing cap on non-drive end
3.10/4.10	V ring

1XB7 terminal box

Part No.	Designation
20.30	Terminal box cover
21.40	Insulating plate (terminal board) without terminals

1XB1 terminal box

Part No.	Designation
20.00	Terminal box, complete
20.30	Terminal box cover
	Terminal post insulator

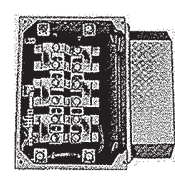
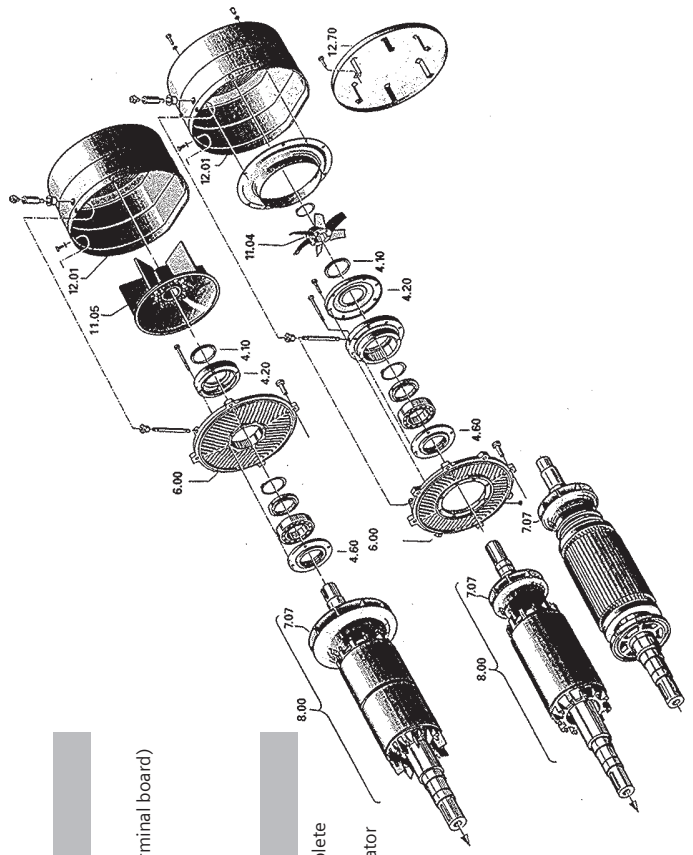

Terminal box 1XB1 631

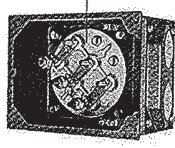

Terminal box 1XB7 622

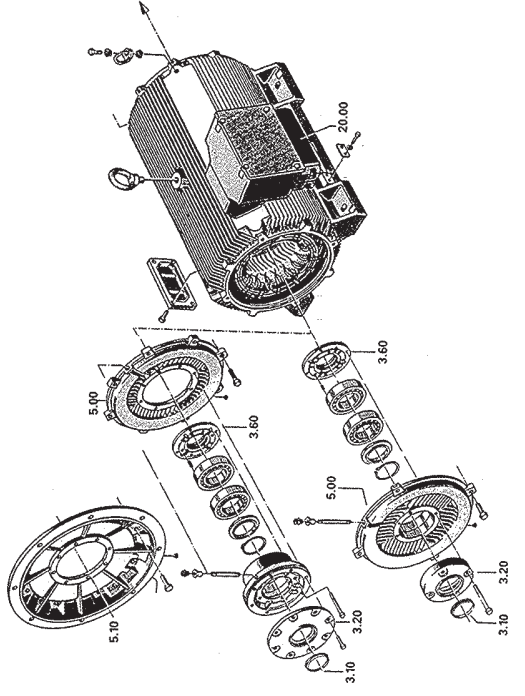

7 Storage

Storing Outdoors

NOTICE

Damage to the motor.

Damage can occur if incorrectly stored.

Take all precautions to protect the motor under extreme climatic conditions, e.g. salt-laden and/or dusty, moist/humid atmospheres.

Choose a dry storage location which is safe from flooding and free from vibration. Repair any damage to the packaging before putting the equipment into storage if this is necessary to ensure proper storage conditions. In order to ensure protection against ground moisture, locate machine, equipment and crates on pallets, wooden beams or foundations. Prevent equipment from sinking into the ground. Do not impede air circulation under the stored items.

Covers or tarpaulins used to protect the equipment against the weather must not come into contact with the surfaces of the equipment. Use wooden spacer elements to ensure that air can circulate freely around the equipment.

Storing indoors

The storage rooms must provide protection against extreme weather conditions. They must be dry, free from dust, frost and vibration and well ventilated.

Bare metal surfaces

For transport, the bare surfaces (shaft ends, flange surfaces, centering edges) should be coated with an anti-corrosion agent which will last for a limited amount of time (Indoor 24 months; Outdoor 6 months)

Condensation drain hole

Open any condensation drain holes to drain the condensation depending on the environmental conditions, every six months at the latest.

Storage temperature

Permissible temperature range: -20 °C to +50 °C

The relative humidity of the air should be less than 60%.

For machines that have a special design regarding the coolant temperature in the operating state or the installation altitude, other conditions could apply regarding the storage temperature. In this case, refer to the machine rating plate for data on the coolant temperature and installation altitude.

Storage time

Turn the shaft once every year to avoid bearing brinelling. Prolonged storage periods reduce the useful life of the bearing grease (aging).

Open bearings

- For open bearings, e.g. 1Z, check the status of the grease when stored for longer than 12 months.
- Replace the grease if it is identified that the grease has lost its lubricating properties or is polluted. The consistency of the grease will change if condensation is allowed to enter.

NOTICE

Storage

The motor can be damaged if you use it or store it unprotected outdoors.

- Protect the motor against intensive solar radiation, rain, snow, ice and dust. Use a superstructure or additional cover, for example.
- If required, contact the Siemens Service Center, or technically coordinate outdoors use.

SIEMENS

Additional Operating Instructions for Motors cooled by separately Driven Fans

Note: To be read in conjunction with the 1LA8 Motor manual.

Description

- Application**

Electrical machines are fitted with a separate fan unit, when the cooling provided by the fan, mounted on the rotor NDE extension, is insufficient, particularly at lower speeds. This happens to machines operating at wide-speed

range. In such cases, this fan is driven through a separate motor called blower motor. The fan fits on an adaptor, which is fixed on the blower motor extension. The blower unit assures effective cooling irrespective of the speed of the main machine. This blower fan unit is fixed to the fan cowl through a fixing plate offering low air resistance.

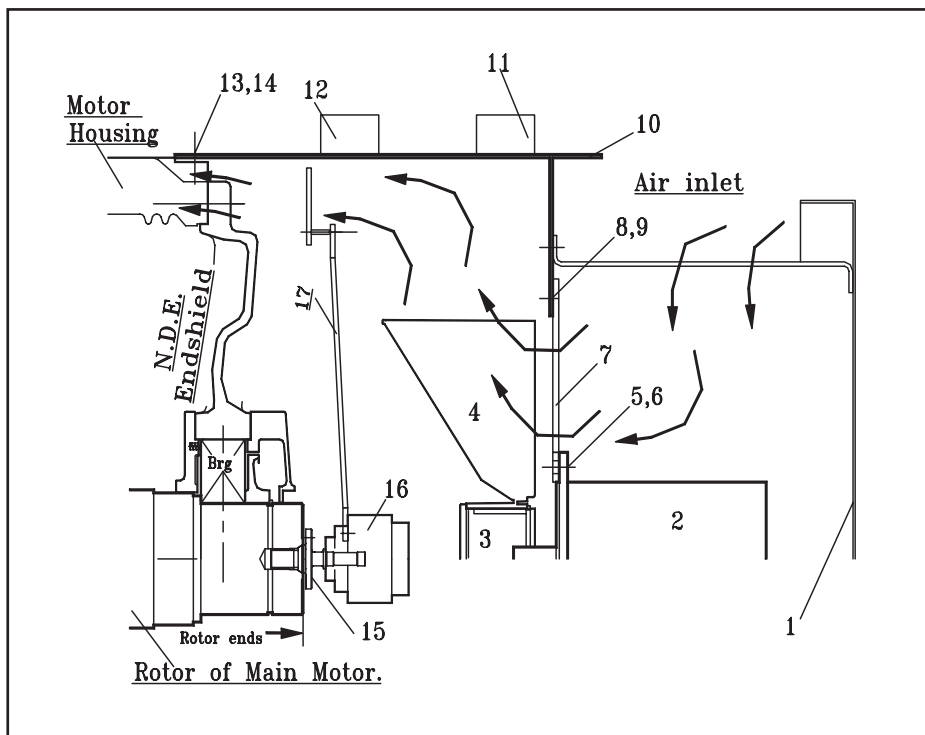

1	Protection Cover
2	Blower motor
3	Fan adaptor
4	Fan (plastic/steel)
5	Hex screw
6	Washer
7	Fixing plate
8	Hex screw
9	Washer
10	Fan cowl
11	Terminal Box- for 2
12	Terminal box- for 16
13	Hex screw
14	Washer
15	Coupling -optional
16	Encoder- optional
17	Torque arm-optional

- General, Connecting Up**

Connect up the blower motor, and optional encoder, as shown in the connection diagram in the terminal box, with due regard to the associated instructions and rating plate data.

- Dismantling, Assembly**

1. Fan Cowl with Fan unit

Before the fan cowl is dismantled, the grease nipple should be removed. The fan unit needs to be removed only for repairs.

2. Fan Cowl with Fan unit + Encoder

Before the fan cowl is removed, the connections from the auxiliary box of fan unit, encoder & the grease nipple should be removed. The fan unit needs to be first removed and the hex. nut fixing the torque arm to the fan cowl should be removed. The fan cowl can now be taken out.

During reassembly it should be ensured that the fan rotates freely inside the cowl. Connect up the blower motor, and optional encoder, as given above.

Additional Operating Instructions for Motors cooled by separately Driven Fans

For motor		Motor		Bearing	
Frame size	Type	Part No.	Designation	Part No.	Designation
315	1LA8	5.00	Bearing shield at drive end	3.20	Outer bearing cap on drive end
		5.10	Flange bearing shield	3.60	Inner bearing cap on drive end
355		6.00	Bearing shield at non-drive end	4.20	Outer bearing cap on non-drive end
		7.07	Integral fan	4.60	Inner bearing cap on non-drive end
400		8.00	Rotor complete with external fan and rolling-contact bearing	3.10/4.10	V ring
		13.08	External blower motor		
		11.05	External fan, bidirectional		
		13.01	Fan cowl		
		13.11	Protective cover		
		20.00	Terminal box, complete with terminals		

1XB7 terminal box	
Part No.	Designation
20.30	Terminal box cover
21.40	Insulating plate (terminal board) without terminals

1XB1 terminal box	
Part No.	Designation
20.00	Terminal box, complete
20.30	Terminal box cover
	Terminal post insulator

Exploded View:-

The exploded view diagram illustrates the assembly of the motor and its cooling fan. Key components shown include the motor frame, bearing shields, fan, rotor, fan cowl, protective cover, and terminal box. The diagram is annotated with part numbers and designations for each component, such as 5.00 for the bearing shield at the drive end, 13.08 for the external blower motor, and 20.00 for the terminal box. The terminal box is shown in an exploded view, with the terminal board and cover positioned around it. The diagram also shows the fan cowl and protective cover components.

Annexure-2

Connecting the grounding conductor

The machine's grounding conductor cross-section must comply with EN IEC 60034-1.

Please also observe installation regulations such as those specified in EN 1 IEC 60204-1.

Basically, there are two ways of connecting a grounding conductor to the machine.

- Internal grounding with a connection in terminal box at the location intended for this purpose and marked accordingly.
- External grounding with connection at the stator housing at the locations intended for this purpose and marked accordingly.

Grounding connection type

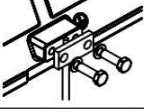
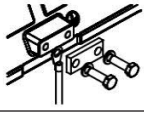
Enclosure grounding method	
Connection of an individual conductor under the external grounding bracket.	
Connection is made using a DIN cable lug under the external grounding bracket. DIN 46 234	

Minimum cross-sectional area of grounding conductor

Minimum cross-section of the phase conductor for installation S [mm ²]	Minimum cross-section of the associated grounding connection [mm ²]
$S \leq 25$	S
$25 < S \leq 50$	25
$S > 50$	0.5 S

Internal ground terminal

When making connections, ensure the following:

- Ensure that the connecting surface is bare and is protected against corrosion using a suitable substance, e.g. acid-free Vaseline.
- Arrange the flat washer and spring washer under the bolt head.
- Locate the cable lug under the clamping bracket.
- Use the terminals designated for the grounding conductor in the terminal box.
- Observe the tightening torque (Page 25) for the locking screw.

External ground terminal

When making connections, ensure the following:

- Ensure that the connecting surface is bare and is protected against corrosion using a suitable substance, e.g. acid-free Vaseline.
- Position the cable lug between the contact bracket and the grounding bracket; do not remove the contact bracket pressed into the enclosure!
- Arrange the flat washer and spring washer under the bolt head.
- Use the marked connection location for the grounding conductor on the stator housing.
- Observe the tightening torque (Page 25) for the locking screw.

Annexure-3

Converter operation

Parameterizing the converter

- If the design of the motor requires connection to a particular converter type, the rating plate will contain corresponding additional information.
- Correctly parameterize the converter. Parameterizing data can be taken from the machine rating plates. You can find parameter data here:
 - In the operating instructions for the converter.
 - In the SIZER engineering tool.
 - In the SINAMICS Configuration Manuals.
- Do not exceed the specified maximum speed limit n_{max} . You can either find this on the rating plate n_{max} or on the supplementary plate for converter operation as the highest speed.
- Check that the machine is cooled sufficiently for commissioning purposes.

Converter input voltage

The insulation system of SIMOTICS machines significantly exceeds the requirements of stress category B (IVIC B= medium stress). If voltage peaks higher than those specified according to IVIC B can occur, then observe the data in the respective Catalog:

- For a line voltage (converter input voltage) up to max. 480 V and operation connected to a SINAMICS G / SINAMICS S converter with uncontrolled/controlled infeed: Comply with the guidelines for configuring motor and converter.
- For line voltages (converter input voltages) higher than 480 V, motors, which are ordered for converter operation, have an appropriate insulation system.
- Operation with a converter from another manufacturer: Comply with the permissible voltage peaks according to IEC 60034-18-41 in accordance with stress category C, dependent on the particular line voltage (converter input voltage) and the motor insulation system.

NOTICE

Material damage caused by an excessively high supply voltage

The insulation system will be damaged if the supply voltage is too high for the insulation system. This can completely destroy the machine.

- Comply with the peak voltages as laid down in the guidelines above.

Reducing bearing currents during operation with converter (low voltage)

Taking the following actions will reduce the bearing currents:

- Ensure that the contacts are made over a large area. Solid copper cables are not suitable for high-frequency grounding because of the skin effect.

Equipotential bonding conductors

Use equipotential bonding conductors:

- between motor and driven machine
- between motor and converter
- between the terminal box and the RF grounding point at the motor enclosure.

Selecting and connecting the cable

As far as possible, use symmetrically arranged, shielded connection cables. The cable shielding, made up of as many strands as possible, must have good electrical conductivity. Braided shields made of copper or aluminum are very suitable.

- The shield is connected at both ends, at the motor and converter.
- To ensure good discharging of high-frequency currents, provide contacting over a large surface area:
 - as contact established through 360° at the converter
 - at the motor, for instance with EMC glands at the cable entries.

- If the cable shield is connected as described, then it ensures the specified equipotential bonding between the motor enclosure and converter. A separate RF equipotential bonding conductor is then not necessary.

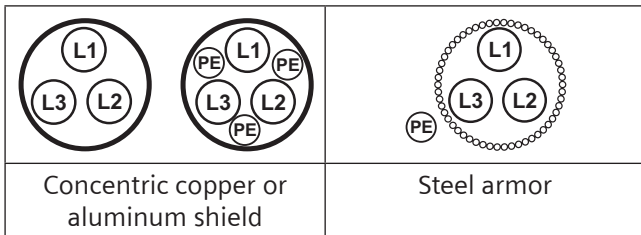

- If the cable shield is not connected due to special secondary conditions, or not adequately connected, then the specified equipotential bonding is not provided. In this particular case, use a separate RF equipotential bonding conductor:
 - Between the motor enclosure and protective ground rail of the converter.
 - Between motor enclosure and driven machine.
 - Use braided flat copper straps or high-frequency cables with finely-stranded conductors for the separate RF equipotential bonding cable.
 - Ensure that the contacts are made over a large area.

Overall system design

To specifically reduce bearing currents, you must consider the system as a whole, which comprises the motor, converter, and driven machine. The following measures support you when reducing bearing currents and help to avoid damage:

- In the overall system, set up a properly meshed grounding system with low impedance.
- Use the common-mode filter (damping cores) at the converter output.
- Limit the rise in voltage by using output filters. Output filters dampen the harmonic content in the output voltage.
- The operating instructions for the converter are not part of this documentation. Refer to the configuration information for the converter.

Insulated bearings when operated with a converter

If the machine is operated from a low-voltage converter, insulated bearings are fitted at the NDE and an insulated encoder with insulated bearings (option).

Comply with the plates on the machine relating to bearing insulation and possible bridges.

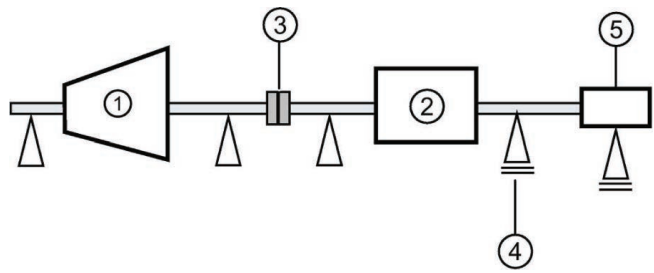

- ① Driving machine
- ② Motor
- ③ Coupling
- ④ Insulated bearings
- ⑤ Insulated tachometer fitting

Figure: Schematic representation of a single drive

NOTICE

Bearing damage

The bearing insulation must not be bridged. Bearing currents can damage bearings.

- Do not bridge the bearing insulation for subsequent installation work, such as the installation of an automatic lubrication system or a non-insulated vibration sensor.
- Please contact the service center if necessary.

Tandem operation

If you connect two motors in series in “tandem operation”, install an insulated coupling between the motors.

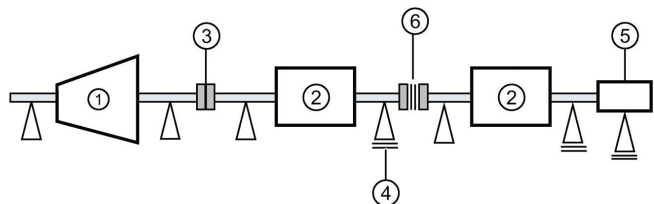

- ① Driving machine
- ② Motor
- ③ Coupling
- ④ Insulated bearings
- ⑤ Insulated tachometer fitting
- ⑥ Insulated coupling

Figure: Schematic representation of a tandem drive

NOTICE

Bearing damage

Bearing currents can flow if the coupling between the motors of the tandem drive is not insulated. This can damage the DE bearings of both motors.

- Use an insulated coupling to link the motors.

Disposal

Siemens products are environment friendly, which predominantly consist of recyclable materials.

For disposals we recommend disassembling and separation into following materials:

METALS: Segregate into Ferrous types for recycling through authorized dealer.

PLASTICS: Segregate as per material type for recycling through authorized dealer. Because of the long lifetime of Siemens Products the disposal guidelines may be replaced by other national regulations when taking the product out of service. The local customer care service is available at any time to answer disposal-related questions.

Customer Care Toll free no. 1800 209 1800

No. MTR4.2-003ab

Siemens Limited

Digital Industries

Motion Control : Low Voltage Motors

R&D Technology Centre

Thane Belapur Road, Airoli Node

Navi Mumbai - 400 708

Fax: +91 22 33265504

E-mail: motors.in@siemens.com

For Life Cycle Support of Products, Systems and Solutions call us on 1800 209 0987

Product development is a continuous process. Consequently the data indicated in this Leaflet is subject to change without prior notice. For latest issue contact our sales offices.

511793