



INSTRUCTION & OPERATION

COMMUNICATIONS MANAGER A53475

NOVEMBER 2009 (REVISED AUGUST 2021)

**DOCUMENT NO. COM-00-08-13
VERSION A.4**

Siemens Mobility, Inc.
700 East Waterfront Drive
Munhall, Pennsylvania 15120
1-800-793-SAFE
www.usa.siemens.com/rail-manuals

Copyright © 2021 Siemens Mobility, Inc.
All Rights Reserved

PRINTED IN U.S.A.

PROPRIETARY INFORMATION

Siemens Industry, Inc. has a proprietary interest in the information contained herein and, in some instances, has patent rights in the systems and components described. It is requested that you distribute this information only to those responsible people within your organization who have an official interest.

This document or the information disclosed herein, shall not be reproduced or transferred to other documents or used or disclosed for manufacturing or for any other purpose except as specifically authorized in writing by **Siemens Mobility, Inc.**

TRANSLATIONS

The manuals and product information of Siemens Mobility, Inc. are intended to be produced and read in English. Any translation of the manuals and product information are unofficial and can be imprecise and inaccurate in whole or in part. Siemens Industry, Inc. does not warrant the accuracy, reliability, or timeliness of any information contained in any translation of manual or product information from its original official released version in English and shall not be liable for any losses caused by such reliance on the accuracy, reliability, or timeliness of such information. Any person or entity that relies on translated information does so at his or her own risk.

WARRANTY INFORMATION

Siemens Industry, Inc. warranty policy is as stated in the current Terms and Conditions of Sale document. Warranty adjustments will not be allowed for products or components which have been subjected to abuse, alteration, improper handling or installation, or which have not been operated in accordance with Seller's instructions. Alteration or removal of any serial number or identification mark voids the warranty.

SALES AND SERVICE LOCATIONS

Technical assistance and sales information on **Siemens Mobility, Inc.** products may be obtained at the following locations:

SIEMENS MOBILITY, INC.	SIEMENS MOBILITY, INC.
2400 NELSON MILLER PARKWAY	939 S. MAIN STREET
LOUISVILLE, KENTUCKY 40223	MARION, KENTUCKY 42064
TELEPHONE: (502) 618-8800	TELEPHONE: (270) 918-7800
FAX: (502) 618-8810	CUSTOMER SERVICE: (800) 626-2710
SALES & SERVICE: (800) 626-2710	TECHNICAL SUPPORT: (800) 793-7233
WEB SITE: www.usa.siemens.com/rail-manuals	FAX: (270) 918-7830

FCC RULES COMPLIANCE

The equipment covered in this manual has been tested and found to comply with the limits for a Class A digital device, pursuant to part 15 of the FCC Rules. These limits are designed to provide reasonable protection against harmful interference when the equipment is operated in a commercial environment. This equipment generates, uses, and can radiate radio frequency energy and, if not installed and used in accordance with the instruction manual, may cause harmful interference to radio communications. Operation of this equipment in a residential area is likely to cause harmful interference in which case the user will be required to correct the interference at his/her own expense.

A.4	AUG 2021	Sec 1	Pg 1-10 Sec 1.7.1.3 Remove Figure 1-6, Add Table 1-1 Pg 1-11 Add Table 1-2
		Sec 3	Pg 3-32 Sec 3.2.1.28 Add GPS Note
		Sec 4	Pg 4-27 Sec 4.3.4.9 Add GPS Note
		Sec 5	Pg 4-60 Sec 4.3.7.1 Add GPS Note
		Sec 6	Pg 5-40 Sec 5.3.1.5 Add GPS Note
		Sec 6	Pg 6-5 Sec 6.5.1 Add GPS Note

Table of Contents

Section	Title	Page
1.0	GENERAL DESCRIPTION.....	1-1
1.1	GENERAL.....	1-1
1.2	DEFINITIONS AND ACRONYMS	1-2
1.3	SCOPE	1-5
1.4	APPLICABLE DOCUMENTS	1-5
1.5	ORDERING INFORMATION.....	1-5
1.6	SPECIFICATIONS.....	1-6
1.7	TERMINATIONS, INDICATIONS, AND CONTROLS.....	1-8
1.7.1	Connector Termination Description.....	1-9
1.7.1.1	Power Connector/ECD [1]	1-9
1.7.1.2	Digital Input Connectors [5] [6].....	1-9
1.7.1.3	GPS Antenna Connector [4]	1-10
1.7.1.4	Serial Connectors [7] [8].....	1-10
1.7.1.5	Ethernet Ports	1-11
1.7.1.6	Relay Outputs	1-12
1.7.1.7	DC Code Line Output	1-13
1.7.1.8	DC Code Line Input Connector	1-14
1.7.1.9	Analog Input/DC Code Line Connector	1-15
1.7.1.10	Echelon® / Power Output Connector	1-16
2.0	APPLICATIONS.....	2-1
2.1	APPLICATION OVERVIEW	2-1
2.1.1	ATCS Network	2-2
2.1.2	GEO Application.....	2-3
2.1.3	CN2000A and CN2000B Application.....	2-4
2.1.4	Ground Fault Tester Support	2-4
2.1.5	VHLC Support.....	2-5
2.1.6	BCM Application.....	2-6
2.1.7	Universal Local Control Panel (ULCP) Interface.....	2-7
2.1.8	Local Panel I/O Interface	2-7
2.1.9	VHF Communicator Application.....	2-7
2.1.10	Remote Communications Manager/ SEAR II	2-8
3.0	INSTALLATION AND CONFIGURATION.....	3-1
3.1	INTERCONNECTION OVERVIEW	3-1
3.1.1	Mounting.....	3-2
3.1.2	Power Connections	3-3
3.1.2.1	Power Conductor Wire Preparation.....	3-4

3.1.2.2	Installing EMI Filter on Power Cable	3-5
3.1.3	Digital and Analog I/O Connections	3-7
3.1.3.1	Connector Wiring Procedure.....	3-7
3.2	USER CONFIGURATION.....	3-8
3.2.1	Path Selection Modes.....	3-8
3.2.1.1	Primary/Backup Mode	3-9
3.2.1.2	Redundant Mode.....	3-10
3.2.1.3	Manual Mode	3-10
3.2.1.4	Path Configuration for WCP.....	3-10
3.2.1.5	Guidelines for ATCS Addressing	3-14
3.2.1.6	General Address Guidelines.....	3-15
3.2.1.7	Communications manager Site Address	3-15
3.2.1.8	Guidelines for RSSI Values	3-16
3.2.1.9	Site Setup Configuration Options.....	3-17
3.2.1.10	Serial Port Configuration Options.....	3-18
3.2.1.11	Ethernet Port Configuration Options	3-21
3.2.1.12	DNS Options	3-23
3.2.1.13	Echelon® Options	3-23
3.2.1.14	Gen/ATCS Field Protocol Options	3-23
3.2.1.15	Gen/ATCS Office Protocol Options.....	3-24
3.2.1.16	Genisys Office Protocol Options	3-24
3.2.1.17	ATCS/HDLC ADM Options.....	3-25
3.2.1.18	ATCS/HDLC UI Options	3-25
3.2.1.19	ATCS/HDLC POLL Options.....	3-26
3.2.1.20	Office Path Options	3-26
3.2.1.21	CN2000A & CN2000B Protocols.....	3-27
3.2.1.22	Dumb Terminal Options.....	3-27
3.2.1.23	Diagnostic Text Options.....	3-28
3.2.1.24	Digital Input Options	3-28
3.2.1.25	Analog Input Options.....	3-29
3.2.1.26	Relay Output Options	3-30
3.2.1.27	Diagnostic Logging Options.....	3-31
3.2.1.28	GPS Configuration Options	3-32
3.2.1.29	SNMP Traps.....	3-32
3.2.1.30	WSA/S2	3-34
4.0	WEB USER INTERFACE (WebUI).....	4-1
4.1	GENERAL.....	4-1
4.2	USER COMPUTER SETUP.....	4-1
4.3	STARTING THE WEB USER INTERFACE (WebUI)	4-2
4.3.1	Web Login.....	4-2
4.3.2	Web UI Welcome Page	4-4
4.3.3	WebUI Troubleshooting.....	4-5
4.3.4	Non-Vital Configuration	4-6

4.3.4.1	Analog Input.....	4-6
4.3.4.2	ATCS Router.....	4-9
4.3.4.3	CDL Log Verbosity Level.....	4-10
4.3.4.4	DC Code Line.....	4-11
4.3.4.5	Diagnostic Log Configuration.....	4-17
4.3.4.6	Digital Input Configuration	4-18
4.3.4.7	Ethernet Ports	4-20
4.3.4.8	Event Log Configuration	4-26
4.3.4.9	GPS.....	4-27
4.3.4.10	Modules	4-28
4.3.4.11	Relay Output.....	4-32
4.3.4.12	Serial Ports	4-34
4.3.4.13	SNMP Configuration.....	4-41
4.3.4.14	WAMS Configuration.....	4-43
4.3.4.15	WSA/S2 Configuration.....	4-44
4.3.4.16	Change Password	4-46
4.3.5	Logs.....	4-48
4.3.5.1	Diagnostic Log	4-48
4.3.5.2	Event Log.....	4-52
4.3.5.3	CDL Log.....	4-55
4.3.6	Maintenance	4-55
4.3.6.1	Software Upgrade	4-56
4.3.6.2	System Time	4-57
4.3.6.3	Configuration.....	4-57
4.3.7	Status.....	4-60
4.3.7.1	Status Menu - GPS	4-60
4.3.7.2	Status Menu – I/O	4-61
4.3.7.3	Status Menu – I/O LED.....	4-61
4.3.7.4	Status Menu - User LED.....	4-62
4.3.7.5	Status Menu – Echelon®	4-62
4.3.7.6	Status Menu – WAMS	4-63
4.3.7.7	Status Menu - Path.....	4-63
4.3.7.8	Status Menu – BCM Diagnostics	4-64
4.3.7.9	Status Menu – Alarms	4-64
4.3.7.10	Status Menu – Ladder Logic.....	4-65
4.3.7.11	Status Menu – Relay Outputs.....	4-66
4.3.7.12	Status Menu – Route Table	4-67
4.3.8	Reports	4-67
4.3.8.1	Reports – Config Report.....	4-68
4.3.8.2	Reports – Version Report	4-69
4.3.8.3	Application	4-70
4.3.9	Web UI Logout	4-77
5.0	LOCALUSER INTERFACE	5-1

5.1	LOCAL USER INTERFACE KEYPAD.....	5-2
5.2	LOCAL USER INTERFACE MENUS	5-3
5.2.1	Shortcut Keys.....	5-3
5.2.2	Test Keys.....	5-3
5.2.3	Direction Keys.....	5-4
5.3	MENU STRUCTURES.....	5-4
5.3.1	Menu.....	5-5
5.3.1.1	Set Date/Time	5-6
5.3.1.2	Set Manual Path.....	5-7
5.3.1.3	View Report	5-7
5.3.1.4	Trace Events.....	5-9
5.3.1.5	Change Settings.....	5-10
5.3.1.6	Monitor I/O	5-53
5.3.1.7	Application	5-59
5.3.1.8	WAMS Test.....	5-60
5.3.1.9	Site Setup	5-61
5.3.1.10	System Reset.....	5-64
5.3.2	Shortcut Key – Site Setup.....	5-65
5.3.2.1	Shortcut Key – Site Setup – Set Date/Time.....	5-66
5.3.3	Shortcut Key - Diag	5-68
5.3.3.1	Shortcut Key – Diag – Exit to Event Log	5-69
5.3.4	Shortcut Key - Versions.....	5-70
5.3.5	Shortcut Key - Status.....	5-72
6.0	OPERATION AND MAINTENANCE	6-1
6.1	GENERAL.....	6-1
6.2	MAINTENANCE	6-1
6.3	USER USB CONNECTOR.....	6-1
6.3.1	USB Connector Operation.....	6-2
6.3.1.1	USB Port Interactive Menus.....	6-2
6.4	SOFTWARE UPGRADE.....	6-5
6.5	STATUS INDICATORS.....	6-5
6.5.1	System Status Indicators.....	6-5
6.5.1.1	Health Status.....	6-6
6.5.1.2	GPS	6-6
6.5.1.3	ECD	6-6
6.5.2	Ethernet Ports Status	6-6
6.5.3	Serial Port Status	6-7
6.5.4	Relay / Code Line Output Status.....	6-7
6.5.5	Analog Inputs/Code Line Input.....	6-8
6.5.6	User Defined Status	6-9
6.5.7	Digital Input Status	6-10

6.5.8	Isolated Power Supply / Echelon®	6-11
7.0	TROUBLESHOOTING	7-1
7.1	GENERAL	7-1
7.2	REPLACING COMMUNICATIONS MANAGER UNIT.....	7-3

List of Figures

Section	Title	Page
Figure 1-1	Communications Manager	1-1
Figure 1-2	Termination, Indicator, and Control Locations.....	1-8
Figure 1-3	Power Connector/ECD.....	1-9
Figure 1-4	Digital Input Connector.....	1-9
Figure 1-5	GPS Antenna Connector.....	1-10
Figure 1-6	Ethernet RJ-45 Orientation and Pin-out.....	1-11
Figure 1-7	Relay Output (De-energized)	1-12
Figure 1-8	DC Code Line Output.....	1-13
Figure 1-9	DC Code Line Output Front Panel LED Indicators.....	1-13
Figure 1-10	Analog Input/DC Code Line Input Connector – Code Line Enabled.....	1-14
Figure 1-11	DC Code Line Input Front Panel LED Indicators.....	1-15
Figure 1-12	Analog Input/DC Code Line Input Connector – Code Line Disabled.....	1-15
Figure 1-13	Echelon® / Power Output Connector.....	1-16
Figure 2-1	Equipment and Network Interfaces.....	2-1
Figure 2-2	Office ATCS Network.....	2-2
Figure 2-3	GEO System Overview	2-3
Figure 2-4	CN2000A & CN2000B Application.....	2-4
Figure 2-5	Ground Fault Tester.....	2-4
Figure 2-6	VHLC Support Application	2-5
Figure 2-7	BCM Application	2-6
Figure 2-8	ULCP Interface	2-7
Figure 2-9	53406 Panel I/O Interface	2-7
Figure 2-10	VHF Communicator Interface.....	2-7
Figure 3-1	Interconnection Overview.....	3-1
Figure 3-2	Mounting Communications Manager	3-2
Figure 3-3	Power and ECD Connector	3-3
Figure 3-4	Power Conductor Wire Installation	3-4
Figure 3-5	Clamp-on EMI Filter (open).....	3-5
Figure 3-6	EMI Filter Installation (showing wire loops).....	3-5
Figure 3-7	EMI Filter Installed.....	3-6
Figure 3-8	Cage Clamp Wire Installation.....	3-7
Figure 3-9	Path Modes	3-8
Figure 4-1	User Computer Setup	4-1
Figure 4-2	Communications Manager Web User Interface Start Up.....	4-2
Figure 4-3	WebUI Opening Screen	4-2
Figure 4-4	WebUI Login Page.....	4-3
Figure 4-5	WebUI Login Confirmation	4-3
Figure 4-6	WebUI Welcome Page.....	4-4
Figure 4-7	Troubleshooting Page.....	4-5

Figure 4-8	Non-Vital Configuration Menu	4-6
Figure 4-9	Configuration Menu – Analog Input	4-6
Figure 4-10	Analog Input Configuration Page.....	4-7
Figure 4-11	Analog Input Parameters	4-8
Figure 4-12	ATCS Router Sub-Menu	4-9
Figure 4-13	ATCS Router Configuration Page.....	4-9
Figure 4-14	Configuration Menu – CDL Log Verbosity.....	4-10
Figure 4-15	DC Code Line Modes.....	4-13
Figure 4-16	DC Code Line Disabled.....	4-13
Figure 4-17	DC Code Line Mode K2 General Parameters	4-14
Figure 4-18	DC Code Line Mode K2 Stations Parameters.....	4-14
Figure 4-19	Configuration Menu – Diagnostic Log.....	4-17
Figure 4-20	Configuration Menu – Digital Input	4-18
Figure 4-21	Digital Input Configuration Page.....	4-18
Figure 4-22	Digital I/O Parameters – Discrete Algorithm.....	4-19
Figure 4-23	Digital I/O Parameters – GFT Algorithm	4-20
Figure 4-24	Ethernet Ports Configuration Menu	4-20
Figure 4-25	Ethernet Ports – Laptop Port.....	4-21
Figure 4-26	Ethernet Port 1 – 4 Path and Protocol Selection.....	4-22
Figure 4-27	Ethernet Port 1 – 4 ATCS/IP Configuration.....	4-23
Figure 4-28	DNS Server Configuration.....	4-25
Figure 4-29	Configuration Menu – Event Log.....	4-26
Figure 4-30	Event Log Configuration Page.....	4-26
Figure 4-31	Configuration Menu – GPS	4-27
Figure 4-32	GPS Configuration.....	4-27
Figure 4-33	Configuration Menu - Modules	4-28
Figure 4-34	Module Configuration.....	4-28
Figure 4-35	No Module Installed	4-29
Figure 4-36	GEO	4-29
Figure 4-37	Universal Local Control Panel (ULCP).....	4-29
Figure 4-38	Panel I/O.....	4-30
Figure 4-39	VHF Communicator (VHFC)	4-30
Figure 4-40	Remote CM/SEAR II	4-31
Figure 4-41	Configuration Menu – Relay Output	4-32
Figure 4-42	Relay Output Configuration Page.....	4-32
Figure 4-43	Relay I/O Parameters.....	4-33
Figure 4-44	Serial Port Menu.....	4-34
Figure 4-45	Serial Laptop Port Parameters	4-34
Figure 4-46	Serial Port 1-2 Field Path and Protocols.....	4-35
Figure 4-47	Serial Port 1-2 Office Primary and Backup 1, 2, & 3 Paths and Protocols.....	4-36
Figure 4-48	Serial Port 3-4 Field Path and Protocols.....	4-37
Figure 4-49	Serial Port 3-4 Office Primary and Backup 1, 2, & 3 Protocols.....	4-38
Figure 4-50	Site Info Configuration Menu.....	4-39
Figure 4-51	Site Info Configuration.....	4-39

Figure 4-52	SNMP Configuration Menu.....	4-41
Figure 4-53	SNMP Configuration Options	4-41
Figure 4-54	WAMS Configuration Menu.....	4-43
Figure 4-55	WAMS Configuration Window	4-43
Figure 4-56	WSA/S2 (Westrace Freight) Configuration Menu.....	4-44
Figure 4-57	WSA/S2 Parameters.....	4-44
Figure 4-58	Change Password Sub-menu.....	4-46
Figure 4-59	Change Password Screen.....	4-46
Figure 4-60	Change Password Procedure.....	4-47
Figure 4-61	Logs Menu.....	4-48
Figure 4-62	Diagnostic Log Menu	4-48
Figure 4-63	Diagnostic Log – Basic View	4-49
Figure 4-64	Diagnostic Log Basic View Navigation Buttons.....	4-49
Figure 4-65	Diagnostic Log – Advanced View	4-50
Figure 4-66	Diagnostic Log Advanced View Navigation Buttons.....	4-50
Figure 4-67	Diagnostic Log – Trace Events.....	4-51
Figure 4-68	Event Log Menu.....	4-52
Figure 4-69	Event Log Menu Basic View.....	4-52
Figure 4-70	Event Log Basic View Navigation Buttons	4-53
Figure 4-71	Event Log – Advanced View	4-53
Figure 4-72	Event Log Advanced View Navigation Buttons	4-54
Figure 4-73	Event Log – Trace Events	4-54
Figure 4-74	CDL Log	4-55
Figure 4-75	Maintenance Menu	4-55
Figure 4-76	Software Upgrade Procedure.....	4-56
Figure 4-77	Maintenance Menu – Setting System Time	4-57
Figure 4-78	Maintenance Menu – Configuration.....	4-57
Figure 4-79	Downloading the Configuration File.....	4-58
Figure 4-80	Uploading the Configuration File	4-59
Figure 4-81	Status Menu	4-60
Figure 4-82	GPS Status.....	4-60
Figure 4-83	I/O Status	4-61
Figure 4-84	I/O LED Status.....	4-61
Figure 4-85	User LED Status.....	4-62
Figure 4-86	Echelon® Node Status.....	4-62
Figure 4-87	WAMS Status	4-63
Figure 4-88	Path Status.....	4-63
Figure 4-89	BCM Diagnostics	4-64
Figure 4-90	Status Menu - Alarms.....	4-64
Figure 4-91	Status Menu – Ladder Logic	4-65
Figure 4-92	Relay Outputs – Change Relay State.....	4-66
Figure 4-93	Route Table.....	4-67
Figure 4-94	Reports Menu	4-67
Figure 4-95	Reports Menu – Config Report.....	4-68

Figure 4-96	Downloading Configuration Information.....	4-68
Figure 4-97	Version Report.....	4-69
Figure 4-98	Downloading Version Report.....	4-69
Figure 4-99	Application Menu	4-70
Figure 4-100	Applications – Site Setup Using CDL Application.....	4-70
Figure 4-101	Upload Ladder Logic Files – Select First File (LLB)	4-71
Figure 4-102	Upload Ladder Logic Files – Select Second Files (LLW).....	4-72
Figure 4-103	Upload Ladder Logic Files - Upload.....	4-72
Figure 4-104	Upload Ladder Logic Files – Uploading in Progress.....	4-73
Figure 4-105	Upload Ladder Logic Files – Files Uploaded Successfully	4-73
Figure 4-106	Remove Ladder Logic Files.....	4-74
Figure 4-107	Ladder Logic Files Removed.....	4-74
Figure 4-108	Upload CDL Application File.....	4-75
Figure 4-109	Browse CDL List	4-75
Figure 4-110:	Upload CDL File	4-75
Figure 4-111	Run Site Setup.....	4-76
Figure 4-112	Web UI Logout.....	4-77
Figure 4-113	Web UI Logout Confirmation	4-77
Figure 5-1	Local User Interface Display and Keypad.....	5-1
Figure 5-2	Local User Interface Keypad Functions	5-2
Figure 6-1	User USB Connector	6-1
Figure 6-2	USB Connector Operation	6-2
Figure 6-3	USB Drive File Structure	6-5
Figure 6-4	System Status Indicators	6-5
Figure 6-5	Ethernet Port Status Indicators.....	6-6
Figure 6-6	Serial Port Status Indicators.....	6-7
Figure 6-7	Relay / Code Line Output Status.....	6-7
Figure 6-8	Analog Inputs / DC Code Line Input Status	6-8
Figure 6-9	User Defined Status Indicator	6-9
Figure 6-10	Digital Input Status and Identification.....	6-10
Figure 6-11	12 VDC Isolated Power Supply / Echelon®	6-11
Figure 7-1	Uninstall Communications Manager – Unplug Connectors	7-3
Figure 7-2	Uninstall Communications Manager – Remove and Replace Unit.....	7-4
Figure 7-3	Re-install Communications Manager – Connect Power and GPS	7-4
Figure 7-4	Re-install Communications Manager – Re-connect Peripheral Equipment.....	7-5
Figure 7-5	Re-install Communications Manager – Returning System On-Line	7-5

List of Tables

Section	Title	Page
Table 1-1:	RJ-45 Connector Pin-out.....	1-10
Table 1-2:	DB-25 Connector Pin-out	1-11
Table 2-1	Communications Manager I/O Descriptions.....	2-9
Table 3-1	Primary Path: WCP Recommended Settings.....	3-11
Table 3-2	Any Backup Path (when a WCP is used as Primary Path).....	3-12
Table 3-3	Primary Path (Not a WCP) Recommended Settings	3-12
Table 3-4	Backup Path WCP Recommended Settings	3-13
Table 3-5	Site Setup Configuration Parameters	3-17
Table 3-6	Serial Port Configuration Summary	3-18
Table 3-7	Serial Ports 1 – 4 Parameters	3-18
Table 3-8	Full-featured Port – Path Type: FIELD.....	3-19
Table 3-9	Partial-featured Port – Path Type: FIELD	3-19
Table 3-10	Full-featured Port – Path Type: Office Primary, Office Backup 1, 2, or 3	3-19
Table 3-11	Partial-featured Port – Path Type: Office Primary, Office Backup 1, 2, or 3	3-20
Table 3-12	Full-featured Port – Protocol: ATCS/HDLC ADM, UI, or POLL	3-20
Table 3-13	Laptop Serial Port Options	3-20
Table 3-14	Ethernet Port Options.....	3-21
Table 3-15	Ethernet Port Options – DHCP Client Disabled.....	3-21
Table 3-16	ATCS/IP Office Options.....	3-22
Table 3-17	DNS Options.....	3-23
Table 3-18	Echelon [®] Configuration Options	3-23
Table 3-19	Gen/ATCS Field Protocol Options	3-23
Table 3-20	Gen/ATCS Office Protocol Options.....	3-24
Table 3-21	Gen/ATCS Office Protocol Options.....	3-24
Table 3-22	ATCS/HDLC ADM Configurable Options	3-25
Table 3-23	ATCS/HDLC UI Configurable Options	3-25
Table 3-24	ATCS/HDLC POLL Configurable Options.....	3-26
Table 3-25	Office Path Configurable Options Primary Office and Backup.....	3-26
Table 3-26	CN2000A & CN2000B Configurable Options	3-27
Table 3-27	Dumb Terminal Parameters	3-27
Table 3-28	Diagnostic Text Parameter Options.....	3-28
Table 3-29	Digital Input Configuration Options	3-28
Table 3-30	Digital Inputs – Algorithm: Discrete.....	3-28
Table 3-31	Digital Inputs – Algorithm GFT.....	3-29
Table 3-32	Analog Input Options.....	3-29
Table 3-33	Relay Output Options.....	3-30
Table 3-34	Diagnostic Logging Options.....	3-31
Table 3-35	GPS Configuration Options	3-32
Table 3-36	SNMP Trap Configurable Options	3-33

Table 3-37	WSA/S2 Parameters	3-34
Table 4-1	Analog Input Parameters and Descriptions	4-8
Table 4-2	ATCS Router Configuration Parameters	4-10
Table 4-3	DC Code Line Settings	4-15
Table 4-4	Ethernet Port 1 – 4 ATCS/IP Configuration Parameters	4-24
Table 4-5	DNS Configuration Parameters	4-25
Table 4-6	Remote CM/SEAR II Configurable Parameters	4-31
Table 4-7	Site Info Configuration Options	4-40
Table 4-8	SNMP Configuration Parameters	4-42
Table 4-9	WAMS Configuration Parameters	4-43
Table 4-10	WSA/S2 Parameters	4-45
Table 7-1	Troubleshooting Chart	7-1

NOTES, CAUTIONS, AND WARNINGS

Throughout this manual, notes, cautions, and warnings are frequently used to direct the reader's attention to specific information. Use of the three terms is defined as follows:



WARNING

INDICATES A POTENTIALLY HAZARDOUS SITUATION WHICH, IF NOT AVOIDED, COULD RESULT IN DEATH OR SERIOUS INJURY. WARNINGS ALWAYS TAKE PRECEDENCE OVER NOTES, CAUTIONS, AND ALL OTHER INFORMATION.



CAUTION

REFERS TO PROPER PROCEDURES OR PRACTICES WHICH IF NOT STRICTLY OBSERVED, COULD RESULT IN A POTENTIALLY HAZARDOUS SITUATION AND/OR POSSIBLE DAMAGE TO EQUIPMENT. CAUTIONS TAKE PRECEDENCE OVER NOTES AND ALL OTHER INFORMATION, EXCEPT WARNINGS.

NOTE

NOTE

Generally used to highlight certain information relating to the topic under discussion.

If there are any questions, contact Siemens Industry, Inc. Application Engineering.

ELECTROSTATIC DISCHARGE (ESD) PRECAUTIONS

Static electricity can damage electronic circuitry, particularly low voltage components such as the integrated circuits commonly used throughout the electronics industry. Therefore, procedures have been adopted industry-wide which make it possible to avoid the sometimes invisible damage caused by electrostatic discharge (ESD) during the handling, shipping, and storage of electronic modules and components. Siemens Industry, Inc. has instituted these practices at its manufacturing facility and encourages its customers to adopt them as well to lessen the likelihood of equipment damage in the field due to ESD. Some of the basic protective practices include the following:

- Ground yourself before touching card cages, assemblies, modules, or components.
- Remove power from card cages and assemblies before removing or installing modules.
- Remove circuit boards (modules) from card cages by the ejector lever only. If an ejector lever is not provided, grasp the edge of the circuit board but avoid touching circuit traces or components.
- Handle circuit boards by the edges only.
- Never physically touch circuit board or connector contact fingers or allow these fingers to come in contact with an insulator (e.g., plastic, rubber, etc.).
- When not in use, place circuit boards in approved static-shielding bags, contact fingers first. Remove circuit boards from static-shielding bags by grasping the ejector lever or the edge of the board only. Each bag should include a caution label on the outside indicating static-sensitive contents.
- Cover workbench surfaces used for repair of electronic equipment with static dissipative workbench matting.
- Use integrated circuit extractor/insertor tools designed to remove and install electrostatic-sensitive integrated circuit devices such as PROM's (OK Industries, Inc., Model EX-2 Extractor and Model MOS-40 Insertor (or equivalent) are highly recommended).
- Utilize only anti-static cushioning material in equipment shipping and storage containers.

For information concerning ESD material applications, please contact the Technical Support Staff at 1-800-793-7233. ESD Awareness Classes and additional ESD product information are also available through the Technical Support Staff.

This Page Intentionally Left Blank

SECTION 1 GENERAL DESCRIPTION

1.0 GENERAL DESCRIPTION

1.1 GENERAL

The Communications Manager is a multifunction communication, monitoring, and control device able to perform non-vital control point functionality as well as communication protocol conversion and message routing. It provides simple user interfaces for monitoring and configuration. For control point applications, it provides a minimal signal input capability with built-in logic execution which can be communicated over the user's network. As a communication protocol converter it supports a wide range of modern and legacy communication protocols and provides inter-message protocol conversion communications. As a message router, it provides configurable and automatic routing capabilities within many different kinds of networks as well as provides network redundancy support.

NOTE	NOTE
	Configuration of the Communications Manager is performed via the web browser or the front panel display and keypad.



Figure 1-1 Communications Manager

1.2 DEFINITIONS AND ACRONYMS

ATCS	Advanced Train Control System. A system wide specification for nodes and communication protocols in a train control network.
BCP	Base Communications Package. A communications package containing a control unit and a radio which provides RF coverage for several WCP locations and locomotives in an ATCS RF network.
CAD	Computer Aided Dispatch. An automated system for processing dispatch business and automating many of the tasks typically performed by a dispatcher. Abbreviated CAD (not to be confused with computer-aided design which is also known as CAD) is application software with numerous features and functions.
CDMA	Code Division Multiple Access. A protocol used in cellular telephony.
Codeplug	This is a configuration file that stores the values of all configurable parameters. This is the common language used by customers familiar with our Wayside Communications Package. This file is also known as the "config file" or the MCF.
CTC	Centralized Traffic Control. This is also known as CAD for Computer Aided Dispatch. This is the system in the office used to control and monitor the railroad signaling system.
DNS	Domain Name Server
ECD	External Configuration Device. A memory device that contains the configuration settings of the unit. The device is external to the unit such that the unit can be replaced without re-configuring anything in the system.
Echelon®	Trademarked by Echelon corporation. We often refer to the physical twisted pair interface as the Echelon interface as it uses transceiver technology designed and licensed by Echelon Corporation.
GEO®	Geographic Signaling System. Siemens vital signaling and control product line.
GPS	Global Positioning System
IP	Internet Protocol

OCG	Office Communications Gateway. Software that runs on a PC that performs similar functions to the WCC/FPD.
PPS	Pulse Per Second. This is a clock signal provided by GPS receivers that is synchronized across the GPS system. It is commonly used by communications equipment to synchronize the time divisions among multiple radios in a co-located communications system.
SEAR II	Siemens Event Analyzer Recorder II. A Siemens product used as an event recorder for crossings and the wayside. The SEAR II also performs the non-vital logic control function at GEO based interlockings.
SNMP	Simple Network Management Protocol.
TCP	Transmission Control Protocol. A transport layer protocol commonly used on top of IP. TCP is a connection oriented protocol providing reliable and in-order delivery of a stream of bytes.
UDP	User Datagram Protocol. A transport layer protocol commonly used on top of IP. UDP is a connectionless protocol that does not guarantee reliability of ordered delivery of messages.
ULCP	Universal Local Control Panel. A Siemens product used for local control of an interlocking. It is commonly installed with a SEAR II at GEO locations.
VHFC	VHF Communicator. Siemens Six Channel VHF Voice/Data Radio unit.
WAMS	Wayside Alarm Management System. The WAMS system is a suite of software created by Siemens Systems used to monitor the status of wayside installations and manage alarms and other information for the wayside installations.
WCC/FPD	Wayside Cluster Controller/Field Protocol Device. The WCC/FPD is often referred to as the Packet Switch. This equipment manages clusters of base stations and other communications links to the field. The WCC/FPD is installed in the office.
WCCMaint	Software that runs on a PC used to configure and manage a network of WCC/FPD equipment. WCCMaint is often used to manage other communications equipment as well such as WCPs and BCPs.

WCM	Wayside Communications Module. A smaller version of the WCC/FPD for use in field installations. The WCM provides protocol conversion and network access through a variety of interface protocols.
WCP	Wayside Communications Package. A communications package containing a control unit and a radio which provides access to the railroads ATCS RF network using a variety of interface protocols.

1.3 SCOPE

This manual serves as the installation and operation guide for the Siemens Communications Manager.



WARNING

THE COMMUNICATIONS MANAGER IS A NON-VITAL PRODUCT. CAUTION MUST BE TAKEN WHEN INTERFACING THE COMMUNICATIONS MANAGER TO ANY VITAL SIGNAL OR CROSSING EQUIPMENT AS THE COMMUNICATIONS MANAGER CANNOT BE USED TO PERFORM, EITHER DIRECTLY OR INDIRECTLY, ANY VITAL FUNCTIONS. ENSURE THE COMMUNICATIONS MANAGER IS INSTALLED PER MANUFACTURER'S INSTRUCTIONS, AND/OR ALL EQUIPMENT INTERCONNECTIONS ARE IN COMPLIANCE WITH RAILROAD PROCEDURES AND SPECIFICATIONS.

1.4 APPLICABLE DOCUMENTS

The following documents will provide additional information in conjunction with this document:

- Siemens Echelon® Handbook (Doc. No.: COM-00-07-09)
- Siemens SEAR II Installation & Operation (Doc. No.: SIG-00-03-18)
- Siemens WAMS Installation & Operation (Doc. No.: SIG-00-03-17)
- Siemens WAMS Test & Inspection Mgmt (Doc. No.: SIG-00-07-08)
- Siemens VHF Communicator Installation & Operation (Doc. No.: SIG-00-03-05-002)
- Siemens GEO Installation & Operation (Doc. No.: SIG-00-05-09)
- Siemens WCM 53447 Installation & Operation (Doc. No.: COM-00-04-08)
- Siemens WCCMAINT Installation & Operation (Doc. No.: COM-00-05-03)
- Siemens OCG Installation & Operation (Doc. No.: COM-00-05-04)
- Siemens Packet Switch Installation & Operation (Doc. No.: COM-00-96-03)
- Siemens WCP CPU II 53105 Installation & Operation (Doc. No.: COM-00-97-10)
- Siemens BCM Installation & Operation (Doc. No.: COM-00-97-19)

1.5 ORDERING INFORMATION

Part Number	Description
9000-53475-0001	Communications Manager

1.6 SPECIFICATIONS

Power Requirements

Input Voltage 9 – 32 VDC, Isolated, Reverse Polarity Protection
Input Current 6 Amps Max @ 13.8 VDC

Connectivity

Power Unipolar 2-Pin Connector
GPS SMA Type Antenna Connector
Digital Inputs

IN-1 - IN-4 8 – Pin Cage Clamp Style
 Max Input Voltage: 120 VAC or VDC
IN-5 - IN-8 8 – Pin Cage Clamp Style
 Max Input Voltage: 120 VAC or VDC

Serial Ports

Port 1 DB-25 – RS-232/RS-422 Sync/Async
Port 2 DB-25 – RS-232/RS-422 Sync/Async
Port 3 RJ-45 – RS-232 Async only
Port 4 RJ-45 – RS-232 Async only

Ethernet Ports

Port 1 RJ-45
Port 2 RJ-45
Port 2 RJ-45
Port 4 RJ-45

Relay I/O

RLY1 – RLY2 6-Pin Cage Clamp Style
 Max Contact Rating: 30 VDC , 5 Amps

Analog Inputs

Analog INPUT 1 – INPUT 4 8-Pin Cage Clamp Style
Code Line In/Out

Echelon®/12 VDC Output 4-Pin Cage Clamp
User Keypad Connectors 1 – RJ-45, 1 – DB-9, 1 - USB
ECD Port USB 2.0

LED Indicators

Power Green
Echelon® Green/Yellow
12 VDC Output Red
Analog IN1 – Analog IN4 Yellow
Code Line IN Red/Green
Code Line OUT Red/Green
RLY1 – RLY 2 Red
User 1 – User 16 Red/Green
Health Yellow
GPS Green
ECD Red/Green
Ethernet Port 1 – Port 4 Yellow/Green
Serial Port 1
 TX Green
 RX Red
 RS-422 Yellow
Serial Port 2
 TX Green
 RX Red
 RS-422 Yellow

Serial Port 3	TX	Green
	RX	Red
Serial Port 4	TX	Green
	RX	Red
Keypad Ports	Ethernet	Yellow/Green
	USB	Red/Yellow/Green
Digital Inputs		
INPUT 1 – INPUT 8		Red
Display		2 Line X 20 Character Vacuum Fluorescent Display
Keypad		Matrix consisting of 25 embossed keys with tactile feedback
Dimensions	Overall	19.0" W x 8.0" H x 2.0" D (48.26 cm W x 20.32 cm H x 5.08 cm D)
Weight		8.25 pounds (3.75 Kg)

1.7 TERMINATIONS, INDICATIONS, AND CONTROLS

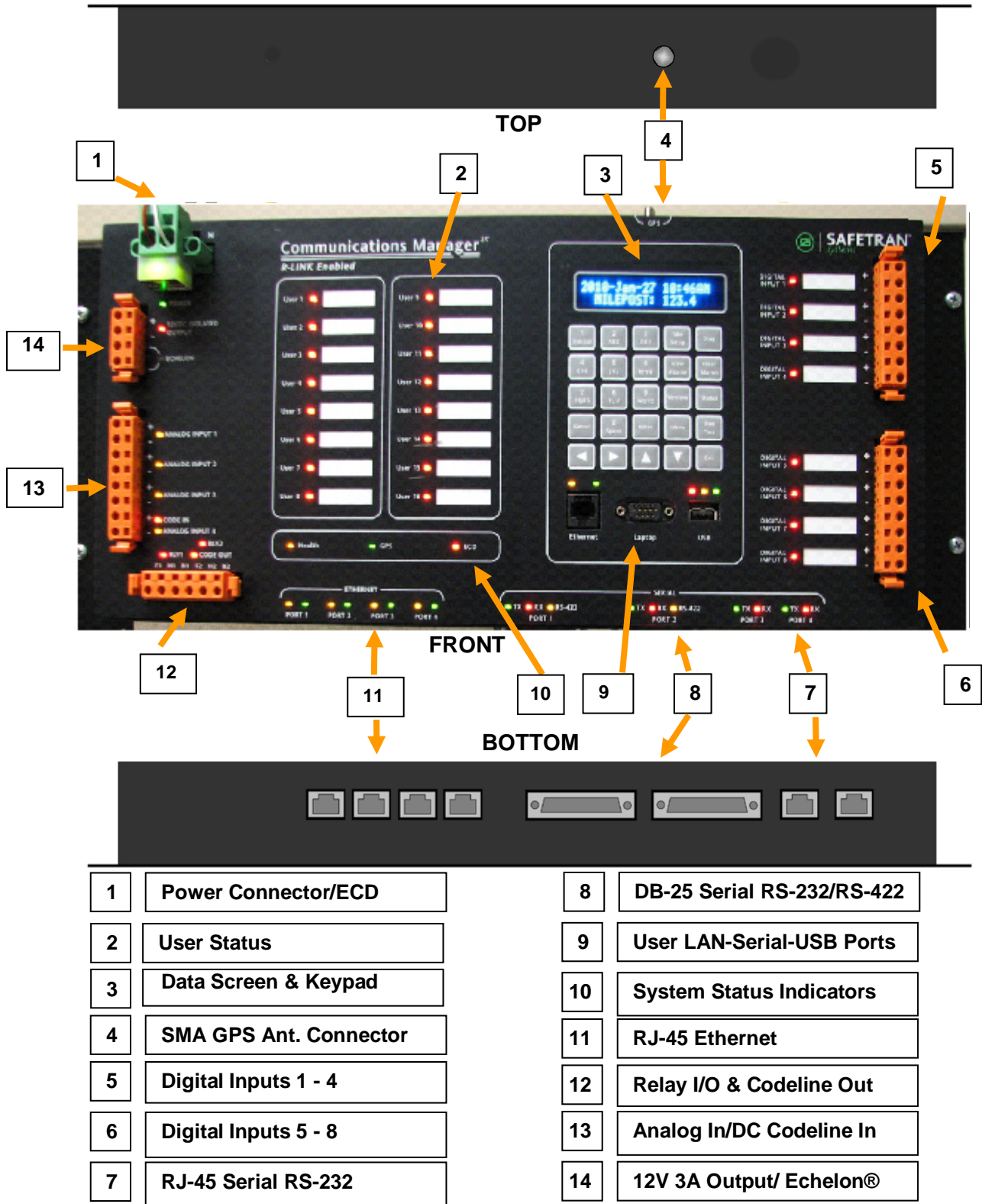

Figure 1-2 Termination, Indicator, and Control Locations

1.7.1 Connector Termination Description

1.7.1.1 Power Connector/ECD [1]

Input DC power for the Communications Manager is terminated with a cage clamp style unipolar connector. Input voltage range of the Communications Manager is 9-32 VDC. The Communications Manager provides 2000V RMS isolation from the battery buss. The DC input is reverse polarity protected. The External Configuration Device (ECD) connects to the Communications Manager via a connector mounted under the power plug using USB connection to the unit. The ECD stores the configuration data for the Communications Manager. The ECD is permanently mounted to the power connector as shown in the diagram below.

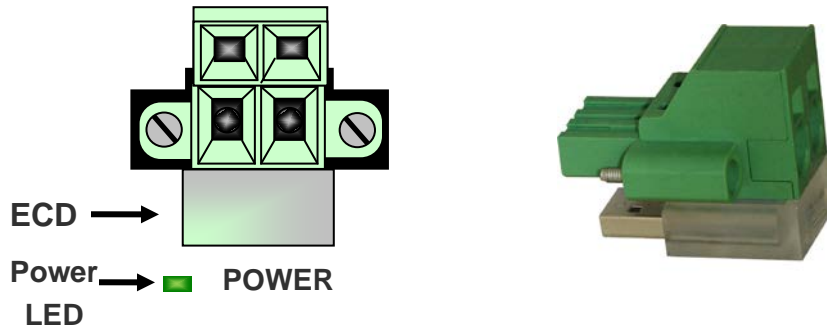

Figure 1-3 Power Connector/ECD

1.7.1.2 Digital Input Connectors [5] [6]

Two 8-Pin cage clamp style connectors are provided for termination of digital signals from wayside devices. Each input has a positive and negative terminal. Maximum input voltages are 120VAC Peak or 120VDC.

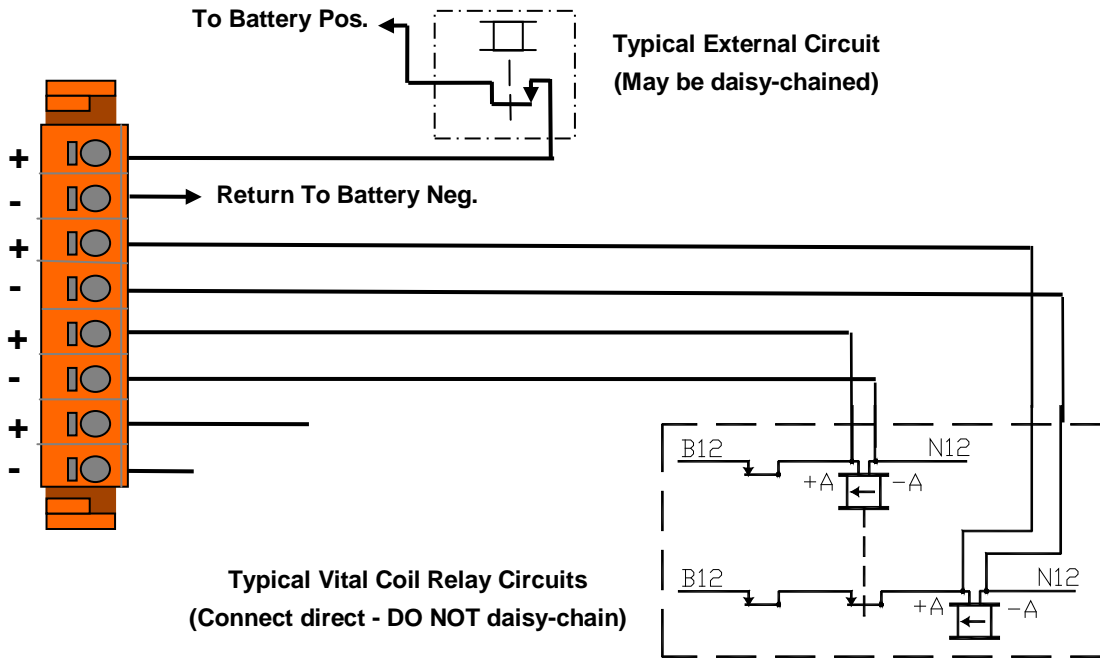

Figure 1-4 Digital Input Connector

1.7.1.3 GPS Antenna Connector [4]

The Communications Manager has a SMA type RF connector for connection of an external GPS antenna.



Figure 1-5 GPS Antenna Connector

NOTE

NOTE

The GPS feature is no longer available in Communications Manager Model 53475 Revision C3 or later.

1.7.1.4 Serial Connectors [7] [8]

Four serial connectors with configurable parameters are provided, 2 DB-25 and 2 RJ-45, to interface to devices requiring RS-232 or RS-422 modes with synchronous or asynchronous operation. Ports one and two are full featured, while ports three and four are RS-232 asynchronous only. Table 1-1 and Table 1-2 display the pin-out arrangement for each style of connector.

CAUTION

CAUTION

SERIAL PORTS 3-4 USE RJ-45 CONNECTORS AS DOES THE ETHERNET PORTS 1-4. ENSURE CONNECTIONS ARE TERMINATED IN THE PROPER LOCATION.

Table 1-1: RJ-45 Connector Pin-out

RJ-45 Connector Pin-out		
Pin #	RS-232 Signal	Direction
1	TXD	Out
2		
3	RTS	Out
4	RXD	In
5		
6	CTS	In
7	DTR	In
8	COMMON	N/A

Table 1-2: DB-25 Connector Pin-out

DB-25 Connector Pin-out			
Pin #	RS-232 Signal	RS-422 Signal	Direction
1	Not Used		
2	TXD	TXD-	Out
3	RXD	RXD-	In
4	RTS	RTS-	Out
5	CTS	CTS-	In
6	NOT USED		
7	COMMON	COMMON	N/A
8	DCD	DCD-	In
9		RXC+	In
10	NOT USED		
11	NOT USED		
12		TXCI+	In
13		CTS+	In
14		TXD+	Out
15		TXCI-	In
16		RXD+	In
17		RXC-	In
18		TXCO+	Out
19		RTS+	Out
20	DTR	DTR-	Out
21		DTR+	Out
22		DCD+	In
23	NOT USED		
24		TXCO-	Out
25	NOT USED		

1.7.1.5 Ethernet Ports

Four Ethernet RJ-45 connectors are provided with the Communications Manager. These ports can be configured for device or network LAN connections. Each Ethernet port is an independent network interface. Figure 1-6 displays the pin-out physical configuration of the Ethernet ports.

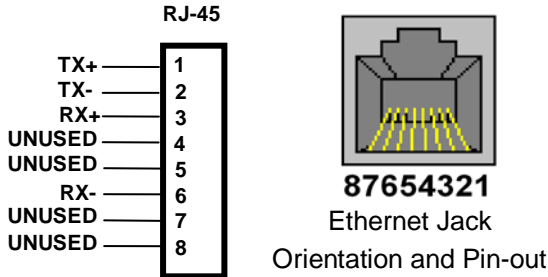

Figure 1-6 Ethernet RJ-45 Orientation and Pin-out

1.7.1.6 Relay Outputs

A Relay Output connector shown in Figure 1-7 interfaces the Communications Manager using “C” contact relay points to control devices. Relay output contacts are rated at a maximum voltage of 30 VDC at 5 Amps.

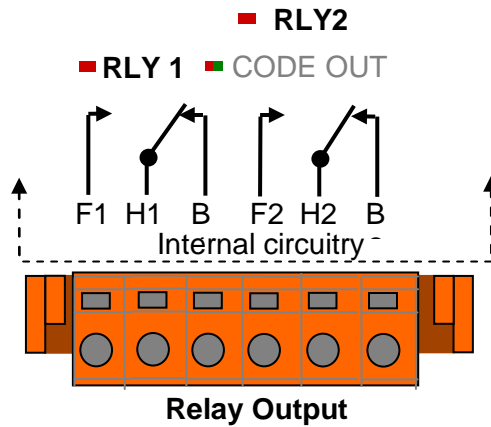

Figure 1-7 Relay Output (De-energized)

WARNING

WARNING
RELAY OUTPUTS MUST BE USED FOR NON-VITAL FUNCTIONS
ONLY.

1.7.1.7 DC Code Line Output

The DC Code Line Output is exported via the Relay 2 output connections to a code line interface box and is rated at 0.9A @ 60 VDC. Relay 1 may be used simultaneously with the DC Code Line output using the Relay 2 connections. Note that DC Code Line functionality and Relay 2 cannot be used simultaneously.

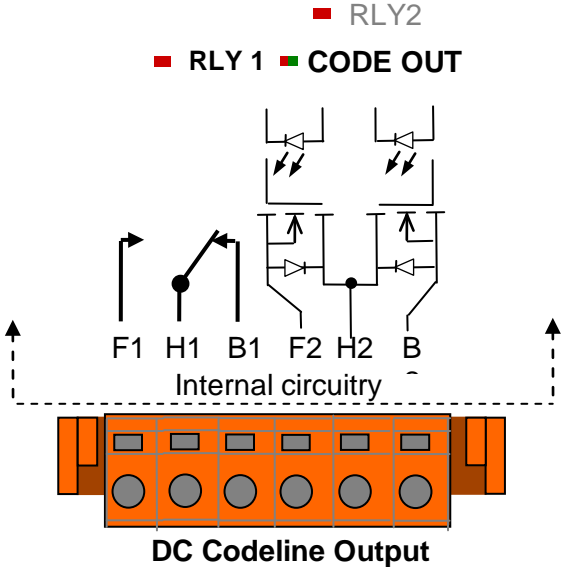

Figure 1-8 DC Code Line Output

LED	Color	Description
Code Out	Green	The green Code Out LED will turn ON when the CM energizes Code Out output 1 and will be off otherwise.
	Red	The red Code Out LED will turn ON when the CM energizes Code Out output 2 and will be off otherwise.

Figure 1-9 DC Code Line Output Front Panel LED Indicators

1.7.1.8 DC Code Line Input Connector

When DC Code Line is enabled Analog Input 4 is disabled and becomes the DC Code Line Input as shown in

LED	Color	Description
Code Out	Green	The green Code Out LED will turn ON when the CM energizes Code Out output 1 and will be off otherwise.
	Red	The red Code Out LED will turn ON when the CM energizes Code Out output 2 and will be off otherwise.

Figure 1-9. Analog inputs 1 through 3 may be used for analog monitoring simultaneously with the DC Code Line input function on Input 4. Note that Analog Input 4 and DC Code Line input functions cannot be used simultaneously.

NOTE Analog Input 4 and DC Code Line input functions cannot be used simultaneously.

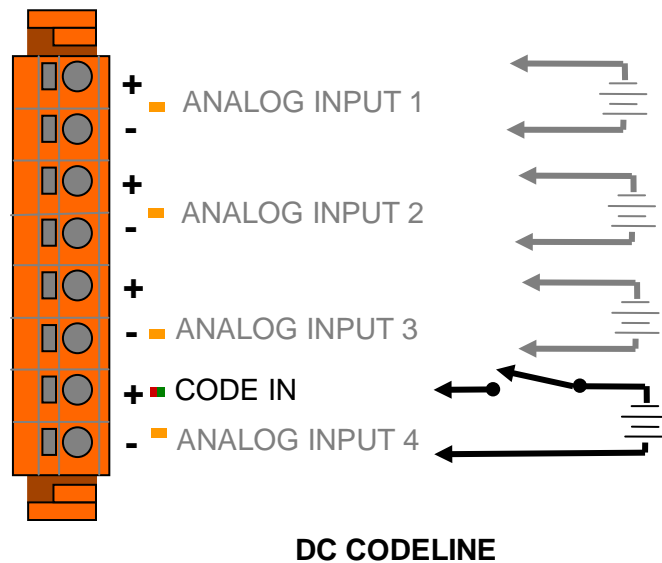

Figure 1-10 Analog Input/DC Code Line Input Connector – Code Line Enabled

LED	Color	Description
Code In	Green	When the CM is configured to support a DC code line protocol, it will light the green Code In LED. The LED stays on all the time while the unit has a DC code line protocol enabled. The CM disables analog input 4 and relay output 2 while this LED is on. The connector pins are used for the Code In and Code Out instead. If the green Code In LED is off, the CM does not have a DC code line protocol enabled and analog input 4 and relay output 2 operate as normal.
	Red	The red Code In LED will turn ON when the Code In input is energized and will turn off when there is no energy on the input. The red LED will follow the pulse applied to the input.

Figure 1-11 DC Code Line Input Front Panel LED Indicators

1.7.1.9 Analog Input/DC Code Line Connector

An Analog Input connector provides 4 analog inputs for wayside devices. DC Code Line uses Analog Input 4 and requires an external interface box. Analog inputs 1 through 3 may be used for analog monitoring simultaneously with the DC Code Line input function on Analog Input 4. Note that Analog Input 4 and DC Code Line input functions cannot be used simultaneously.

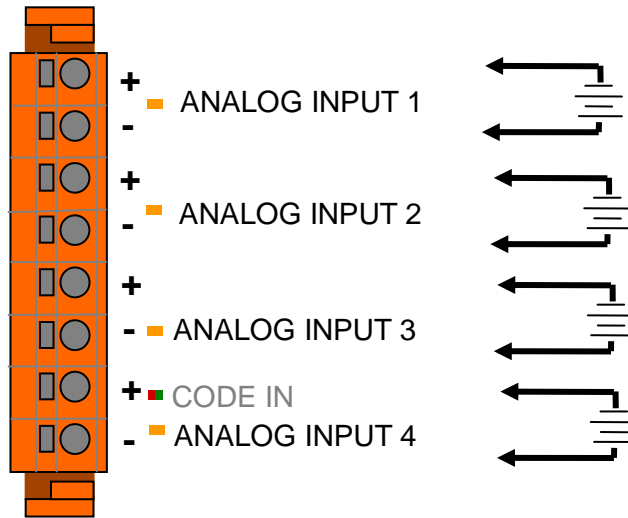

BATTERY INPUTS

Figure 1-12 Analog Input/DC Code Line Input Connector – Code Line Disabled

1.7.1.10 Echelon® / Power Output Connector

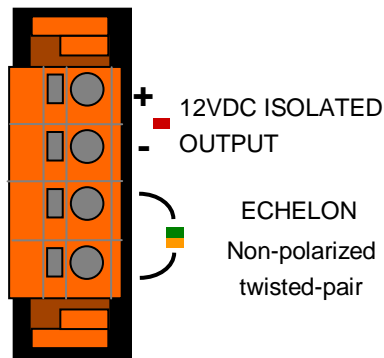

Figure 1-13 Echelon® / Power Output Connector

⚠ WARNING

WARNING
THE 12 VOLT ISOLATED OUTPUT MAY BE USED TO POWER NON-VITAL EQUIPMENT ONLY.

SECTION 2 APPLICATIONS

2.0 APPLICATIONS

The Communications Manager is designed for use in a variety of applications. The following are some examples of the Communications Manager's capabilities. Contact Siemens Customer Service for assistance in developing desired applications.

2.1 APPLICATION OVERVIEW

The Communications Manager's versatility enables it to be used in an array of applications. Figure 2-1 displays Communications Manager's equipment and network interface capabilities.

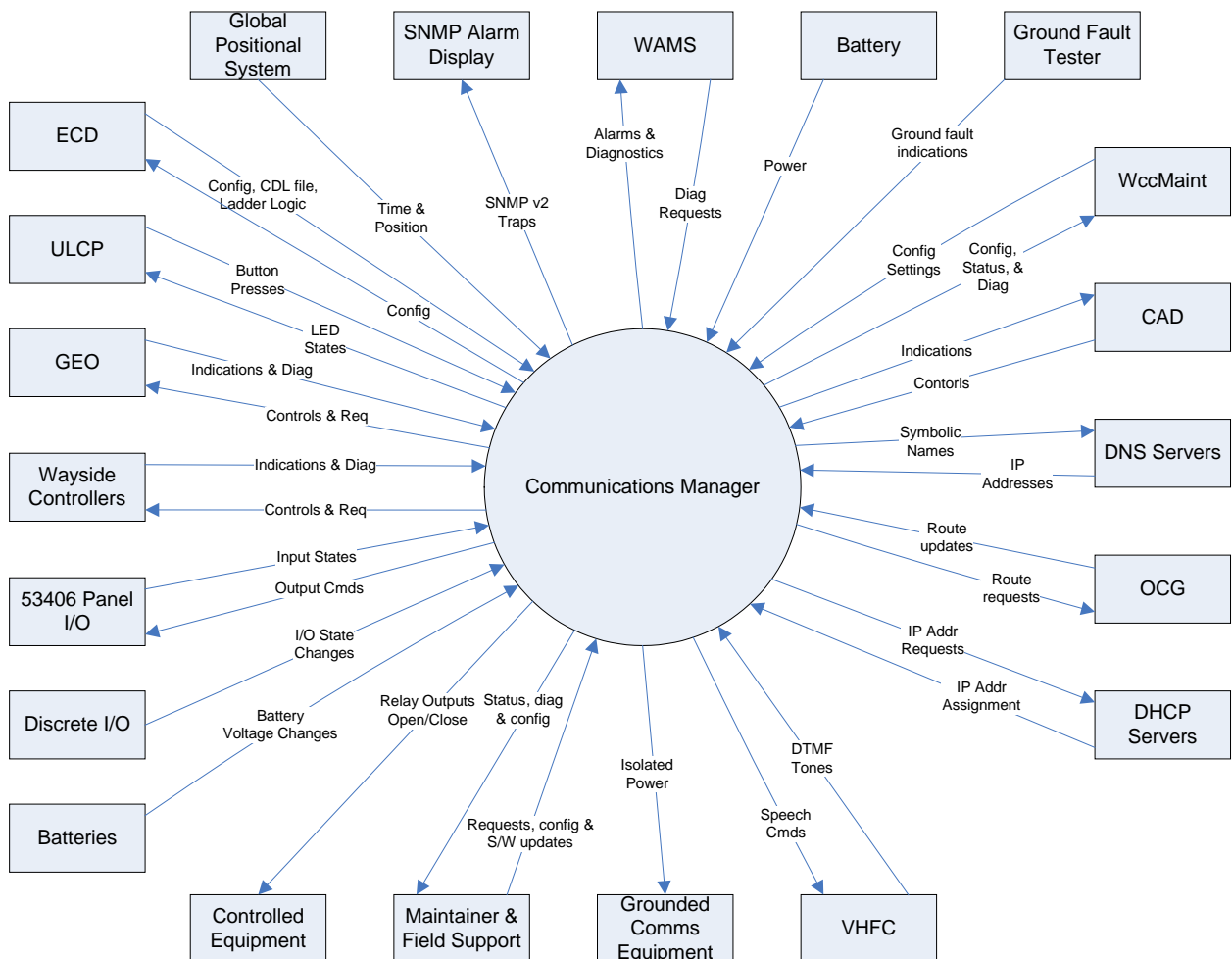

Figure 2-1 Equipment and Network Interfaces

2.1.1 ATCS Network

A typical Office ATCS network is shown in the diagram below. The Communications Manager is configured to provide either Primary/Backup or Redundant paths between the Communications Manager and the ATCS Office.

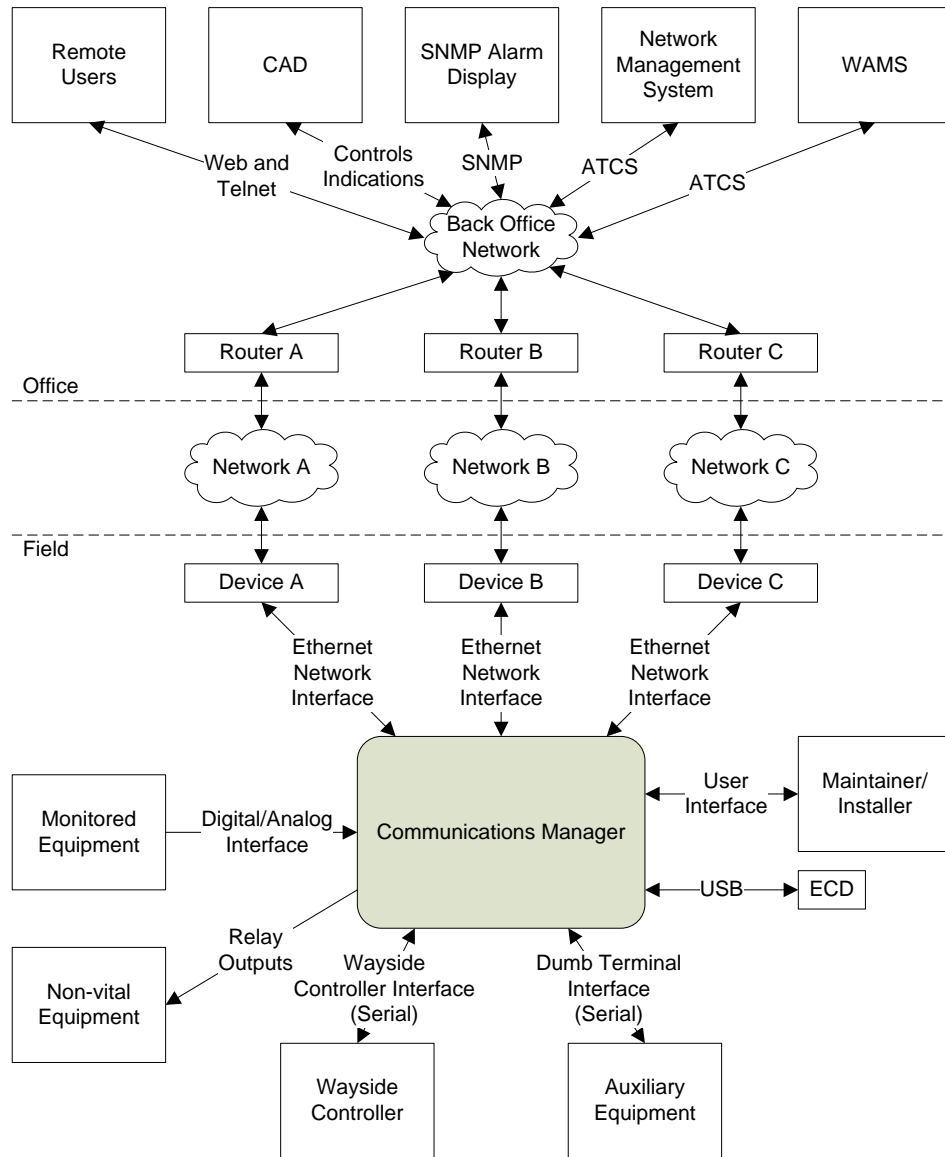

Figure 2-2 Office ATCS Network

2.1.2 GEO Application

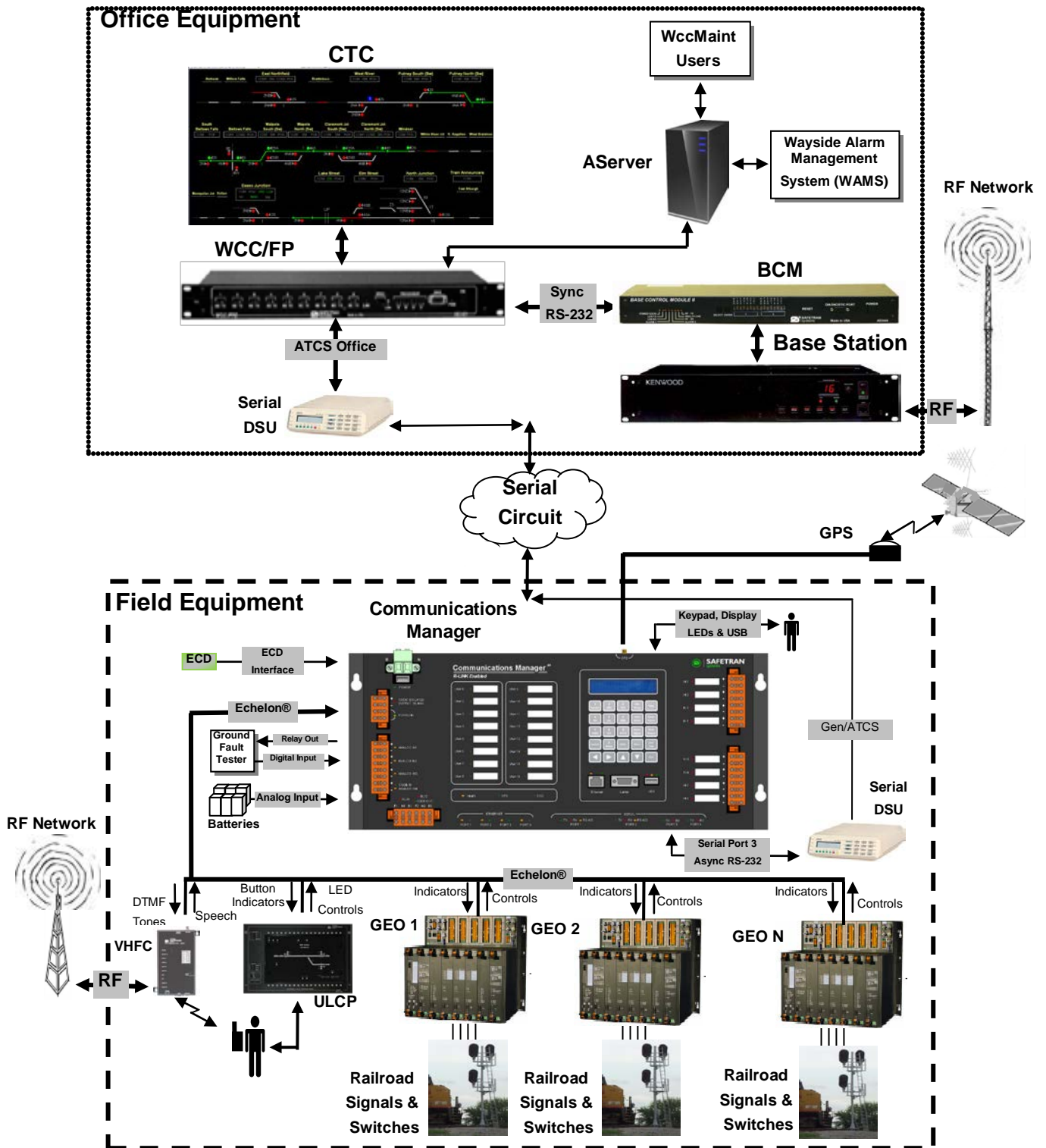

Figure 2-3 GEO System Overview

2.1.3 CN2000A and CN2000B Application

The CN2000A and CN2000B protocols are proprietary to the CN Railway. Multi-drop code units are supported in this application.

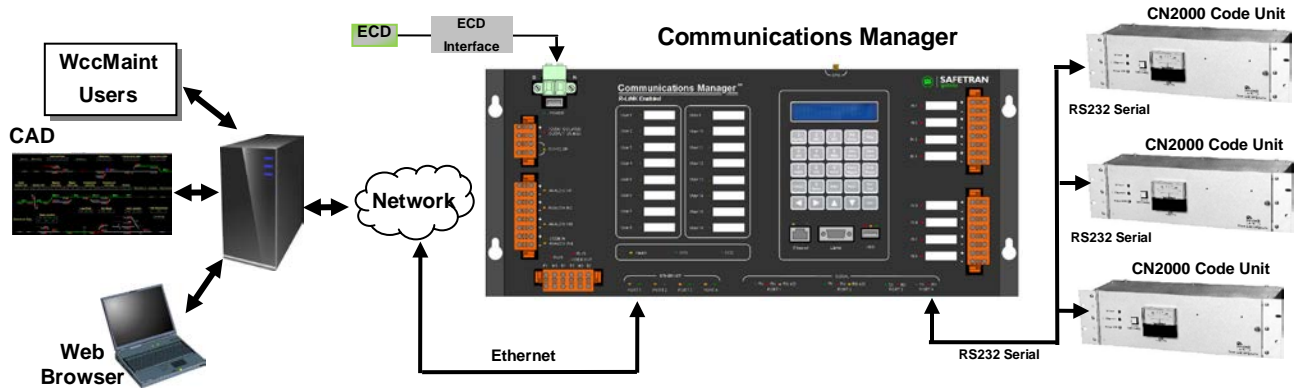

Figure 2-4 CN2000A & CN2000B Application

2.1.4 Ground Fault Tester Support

The figure below shows connection of Ground Fault Tester modules to the Communications Manager digital inputs.

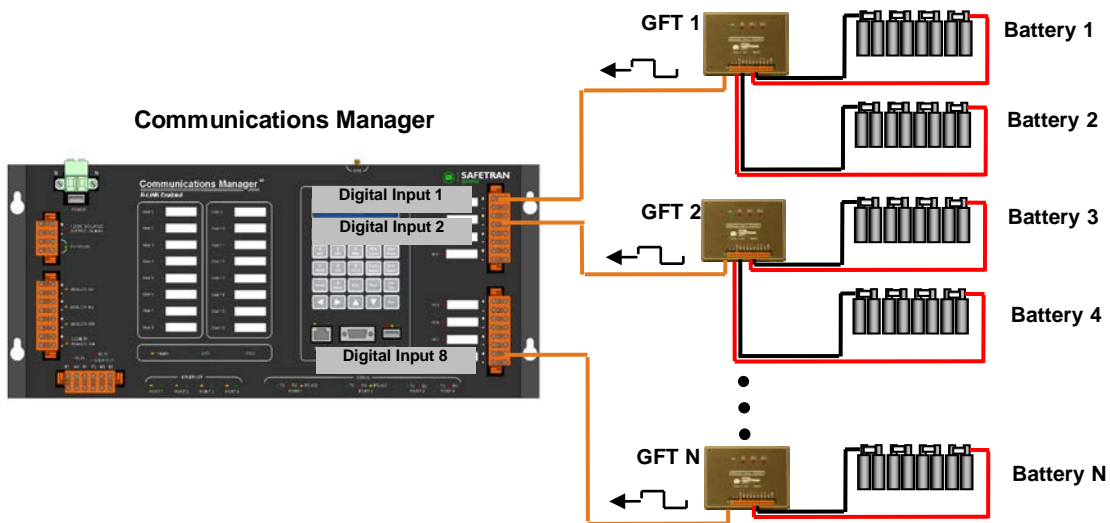

Figure 2-5 Ground Fault Tester

2.1.5 VHLC Support

Communication Manager supports VHLC applications. The diagram below displays an example Vital Harmon Logic Controller (VHLC) application. Communications Manager uses HDLC ADM or Genisys protocol to communicate with VHLC. The Diagnostic Text protocol allows a remote user to access the VHLC's diagnostic port.

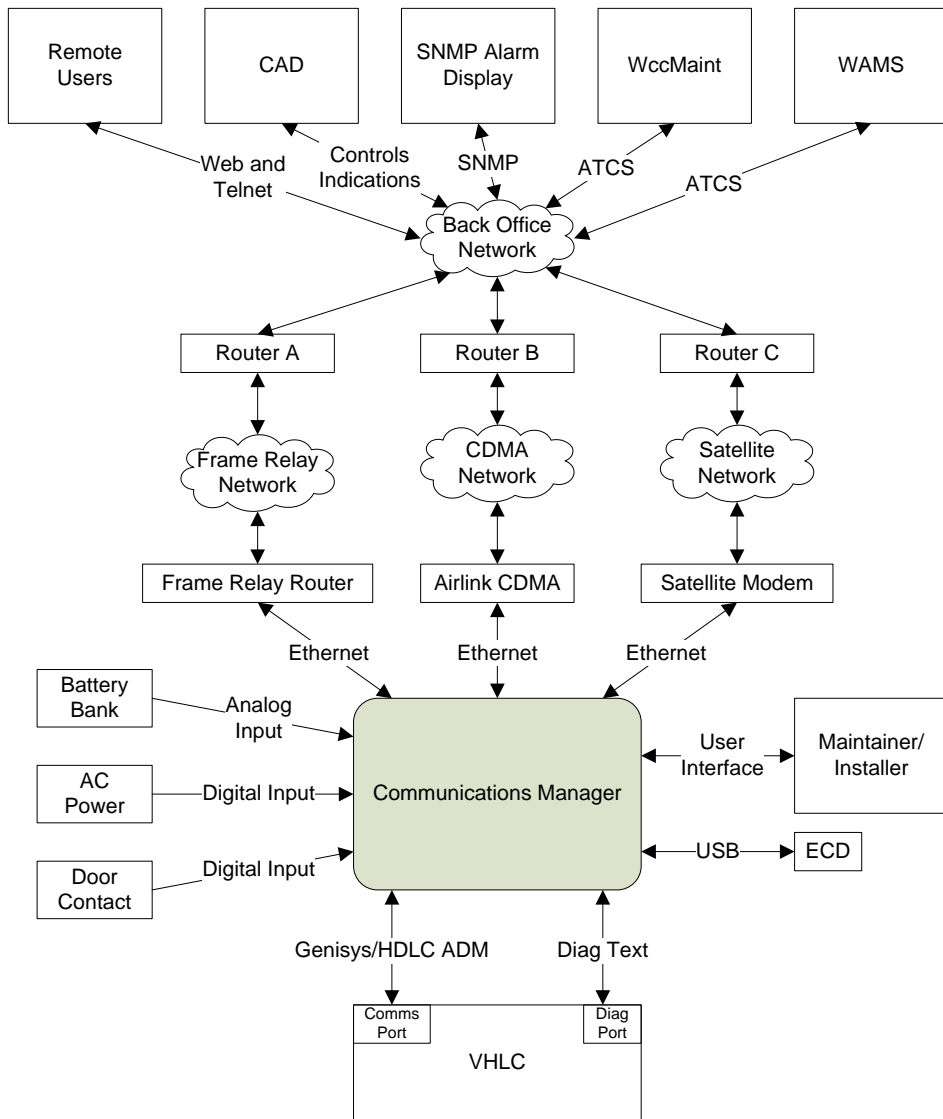

Figure 2-6 VHLC Support Application

2.1.6 BCM Application

The diagram below displays an example Base Station Radio installation using the Siemens Base Station Control Module. The BCM is powered, controlled, and monitored by the Communications Manager.

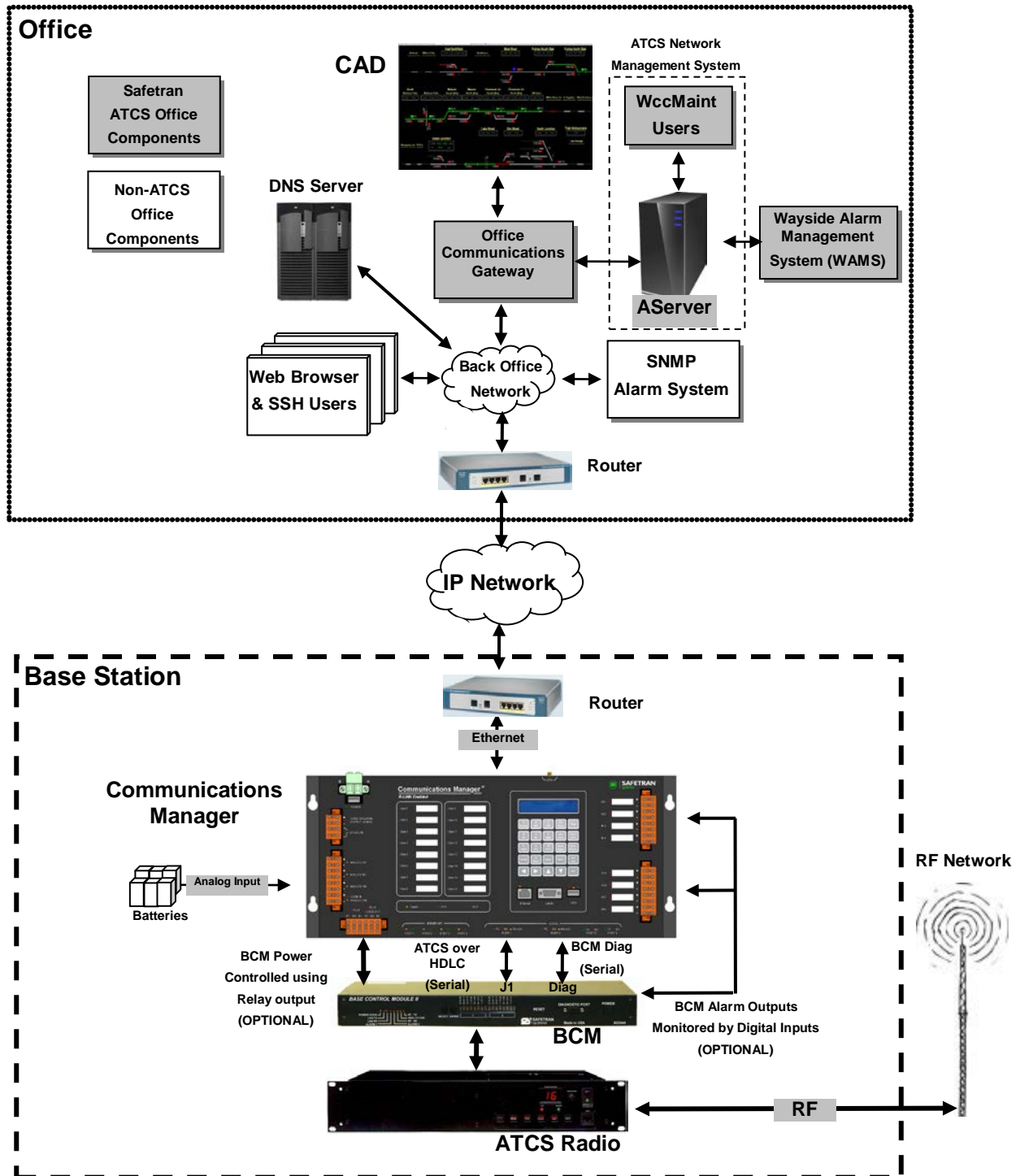

Figure 2-7 BCM Application

2.1.7 Universal Local Control Panel (ULCP) Interface

The figure below shows an application using the Siemens ULCP. The ULCP communicates with the Communications Manager via the Echelon® network.

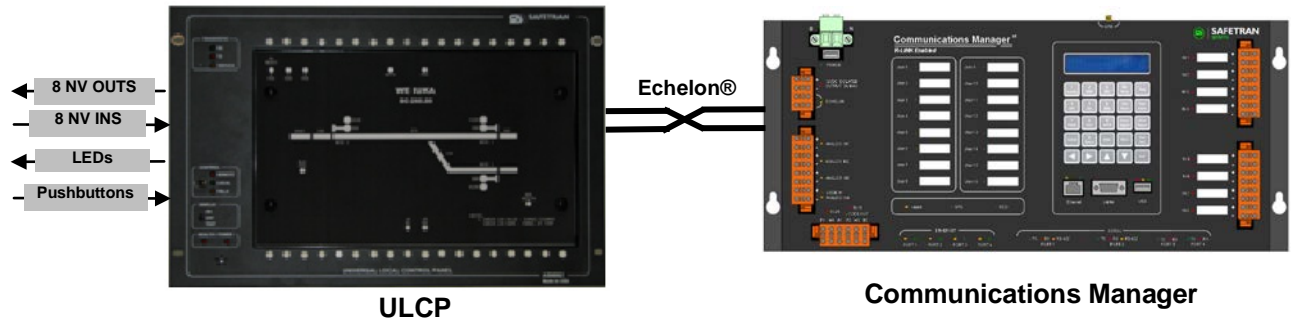

Figure 2-8 ULCP Interface

2.1.8 Local Panel I/O Interface

The diagram below displays an application using a legacy Siemens 53406 Panel I/O supporting a custom Local Control Panel. The Panel I/O uses the Echelon® node network to communicate with the Communications Manager.



Figure 2-9 53406 Panel I/O Interface

2.1.9 VHF Communicator Application

The figure below shows a VHF Communicator application using the Echelon® network.

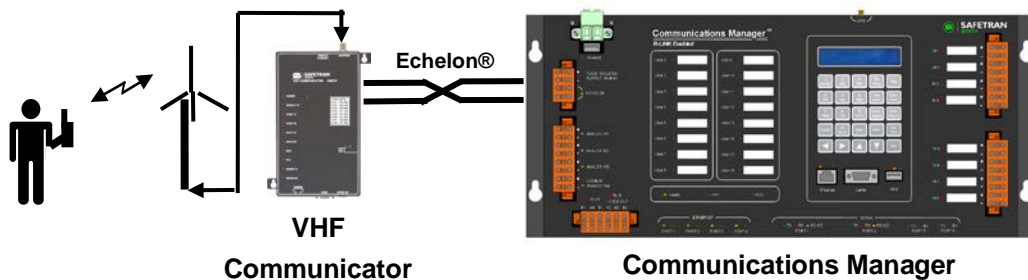
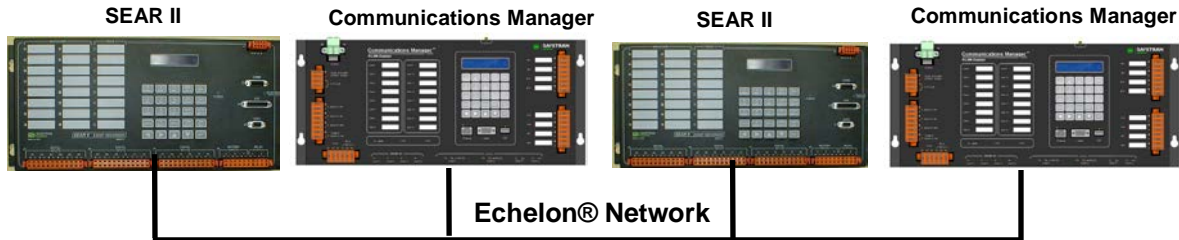

Figure 2-10 VHF Communicator Interface

2.1.10 Remote Communications Manager/ SEAR II

The Communications Manager (CM) supports communicating ladder logic states to other CM units or SEAR II units over the Echelon network. The CM functions identically to the SEAR II for this feature. The feature allows you to distribute ladder logic programmable functions between multiple systems. The ladder logic programs on each system can exchange information as data bits in messages on the Echelon network.



Each CM sends messages to each remote unit configured in the unit's settings. The messages contain data bits as set by the CM's ladder logic program. The CM copies received data bits from the remote units into the ladder logic bit map. That allows the ladder logic program to evaluate the received data from the remote unit. Each unit sends ladder logic bits to the remote units in its configuration every 10 seconds and on the change of state of any ladder logic bit.

If the CM does not receive a message from the remote unit for approximately 40 seconds, the CM will log the module is offline and the CM will clear the "Node Online" bit for that unit in the ladder logic executive bits.

When a sent or received bit changes state, the CM will log the change using the bit's assigned label from the ladder logic label file.

Table 2-1 Communications Manager I/O Descriptions

Interface	Description
Ethernet Ports 1 - 4	Used for office or field communication, depending on system settings.
Laptop Ethernet Port	Used to allow Web Browser access to the unit.
GPS Interface	Used to connect the internal GPS receiver to an external antenna.
Serial Ports 1 and 2	Used for communication with office or field devices depending on system settings. These ports can handle sync or async operation in RS-232 or RS-422 line mode.
Serial Ports 3 and 4	Used for communication with office or field devices depending on system settings. These ports only handle RS-232 line mode.
Echelon®	Used to communicate to other Siemens devices such as GEO, ULCP, Panel I/O, VHFC, etc.
Digital Inputs	Used to monitor and record discrete I/O at the location (including Vital I/O) as well as Ground Fault Testing.
Analog Inputs	Used to monitor and record battery bank voltages at the location.
Relay Outputs	Used to control external equipment.
DC Code Line	Used to interface to legacy DC Code Line equipment and run DC Code Line protocols.
Isolated Power Output	Used to provide isolated power to external communications devices.
USB Flash Drive	Used by Maintainer to: <ul style="list-style-type: none"> •Load new software •Download Logs •Upload/Download Configuration.
Front Panel Interface	This consists of: <ul style="list-style-type: none"> •Display •Keypad •LEDs embedded within the overlay. Used by Maintainer to view unit status, configure unit, etc.
ECD	An external configuration device. This device holds the site specific configuration parameters. The ECD is part of the power connector assembly.

This Page Intentionally Left Blank

SECTION 3 INSTALLATION AND CONFIGURATION

3.0 INSTALLATION AND CONFIGURATION

3.1 INTERCONNECTION OVERVIEW

The installation of the Communications Manager will involve a variety of connections depending on the complexity of the application. An overview of the Communications Manager connections is shown in Figure 3-1.

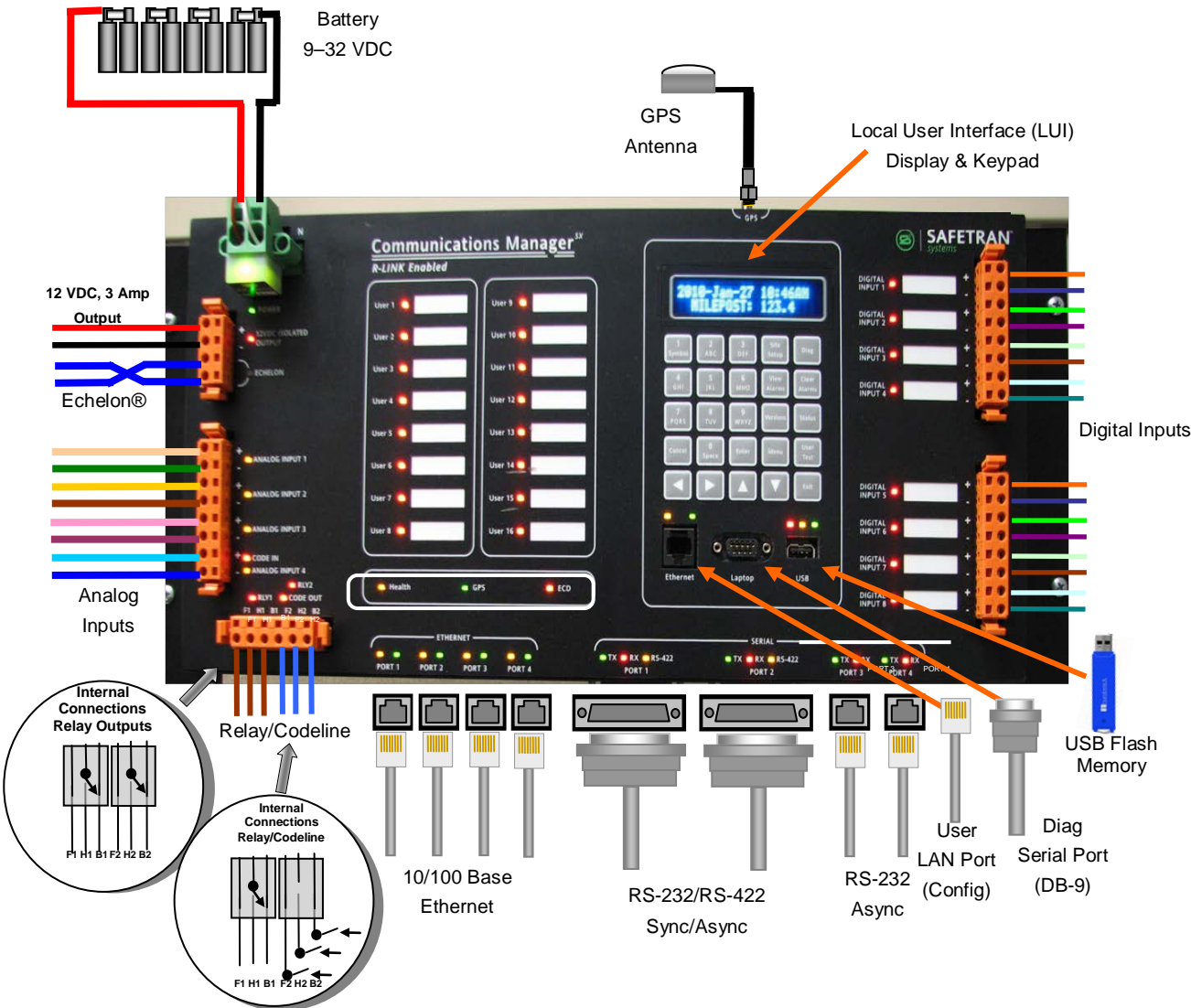

Figure 3-1 Interconnection Overview

3.1.1 Mounting

The Communications Manager is designed for either 19 inch rack or wall mounting. Select a mounting position with ample clearance for the GPS antenna connection on the top and the Ethernet and serial connectors on the bottom.

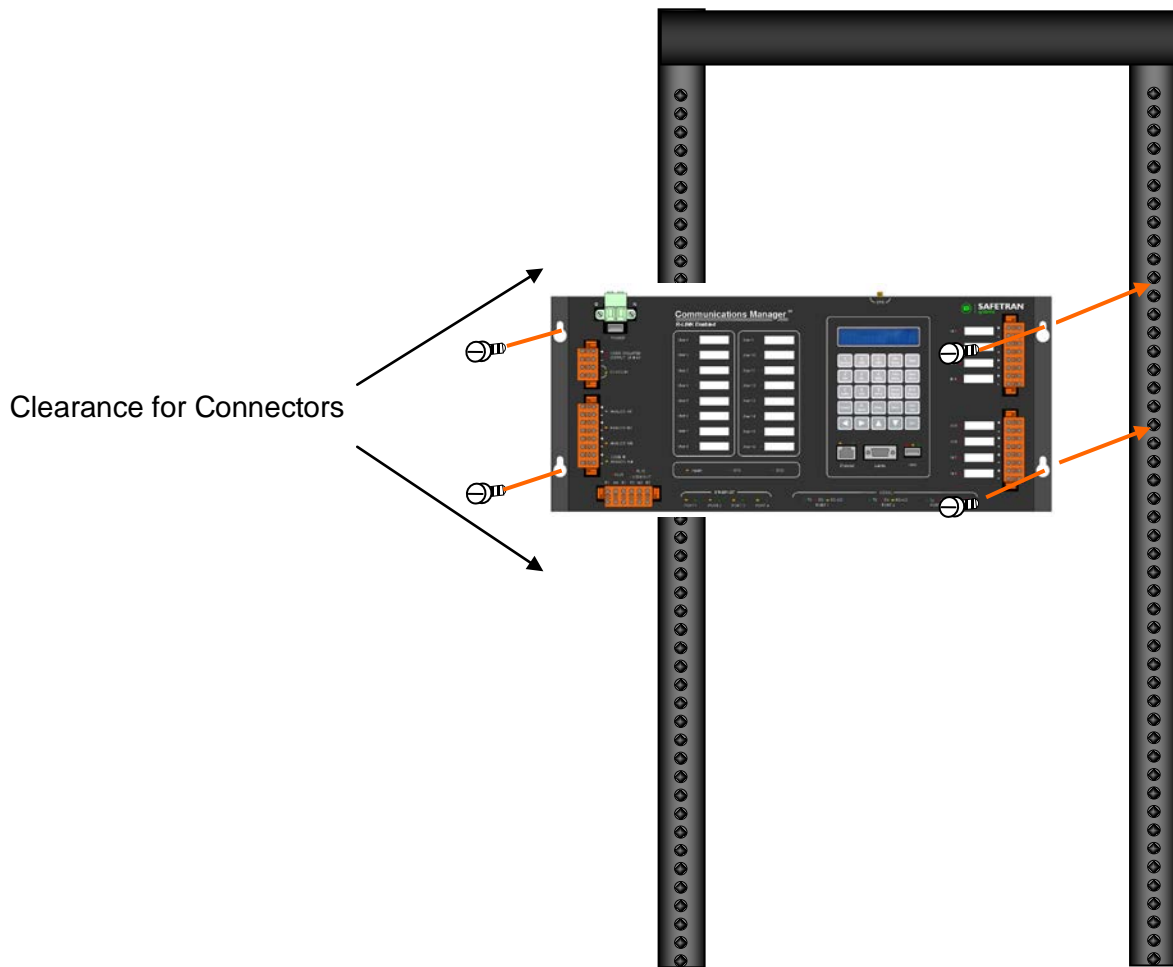

Figure 3-2 Mounting Communications Manager

3.1.2 Power Connections

DC Power is supplied to each Communications Manager unit via a 2-terminal Cage Clamp type connector located on the front panel. This connector also holds the External Configuration Device (ECD). The power connector and ECD can only be inserted into the corresponding connector on the front panel in one direction. Battery polarity is indicated on the Communications Manager front panel.



Figure 3-3 Power and ECD Connector

⚠ CAUTION

CAUTION

WHEN INSTALLING THE POWER / ECD CONNECTOR, ENSURE THE ECD IS PROPERLY ALIGNED BEFORE INSERTING THE PLUG FULLY. DO NOT FORCE THE ECD CONNECTOR AS THE RECEPTACLE MAY BECOME DAMAGED.

⚠ CAUTION

CAUTION

USE THE APPROPRIATE WIRE SIZE TO POWER THE COMMUNICATIONS MANAGER. WIRE SIZE SHOULD SUPPORT 6 AMPERES AT NOMINAL INPUT VOLTAGE. EXTENDED WIRE LENGTHS WILL REQUIRE LARGER WIRE SIZE TO AVOID EXCESSIVE VOLTAGE DROP.

3.1.2.1 Power Conductor Wire Preparation

Verify that “B” and “N” supply wires are installed in the power connector correctly before inserting the power connector into the mating connector on the front panel. Prepare the wires as follows:

1. Strip approximately 1/4 inch (6 mm) of insulation from the end of the wire.
2. Install EMI filter on cable.
3. Open the spring loaded receptor, by inserting small flat blade screwdriver in the recessed opening and insert the stripped end of the wire until it stops, making sure the wire insulation is not in the metal contactors.
4. Remove the screwdriver to close the receptor and verify the wire is secure.



Figure 3-4 Power Conductor Wire Installation

3.1.2.2 Installing EMI Filter on Power Cable

In order to reduce radiated electromagnetic interference in the Communications Manager power cable, a clamp-on EMI filter (part number Z590-00010-0001) must be installed as follows:

Step 1. Open the clamp-on EMI filter as shown in Figure 3-5.



Figure 3-5 Clamp-on EMI Filter (open)

Step 2. Place the open EMI filter under the power cable approximately 1.5 inches from the stripped end of the wires.

Step 3. Wrap the long end of the cable around the outer surface of the filter and back through the center of the filter one time (totaling two wire runs inside the filter – see Figure 3-6).



Figure 3-6 EMI Filter Installation (showing wire loops)

Step 4. Snap the filter closed (see Figure 3-7).



Figure 3-7 EMI Filter Installed

NOTE

NOTE

Failure to install the EMI Filter may result in unwanted EMI and RFI interference to adjacent equipment.

3.1.3 Digital and Analog I/O Connections

Each discrete input on the I/O connectors has both a positive and a negative terminal connection. This allows for wiring of a larger variety of discrete I/O than only using a common negative. It also prevents problems such as 'sneak paths' when adjacent inputs are wired. Polarity is marked on the case adjacent to each connector.

3.1.3.1 Connector Wiring Procedure

The female connectors supplied with the Communications Manager for the digital input connections will accept wire sizes in the range of #28 AWG to #14 AWG. The connectors contain spring-loaded cage-clamps for attachment of the wires. Each connector consists of a row of wire receptors and actuator spring holes to open and close the cage clamps. Wire each connector as follows:

1. Remove the supplied connector from the mating receptacle on the unit.
2. Select a proper gauge wire for the application (range is #28 to #14 AWG).
3. Strip approximately 5/16 inch (8 mm) of insulation from the end of the wire.
4. Insert the blade of a small screwdriver into the actuator spring hole associated with the wire hole. The screwdriver blade should be no more than 0.10 inches wide and 0.020 inches thick (2.5 mm x 0.5 mm).
5. Lever the wire cage clamp open by pressing straight down on the screwdriver. Visually note that the contactor receptacle has opened up sufficiently to insert stripped wire. Fully insert wire into receptacle, taking care not to insert wire jacket insulation into metal contactors.
6. Remove screwdriver. Gently tug on the just-inserted wire to ensure the receptacle properly retains the installed wire.
7. Repeat for each wire to be added to the connector.

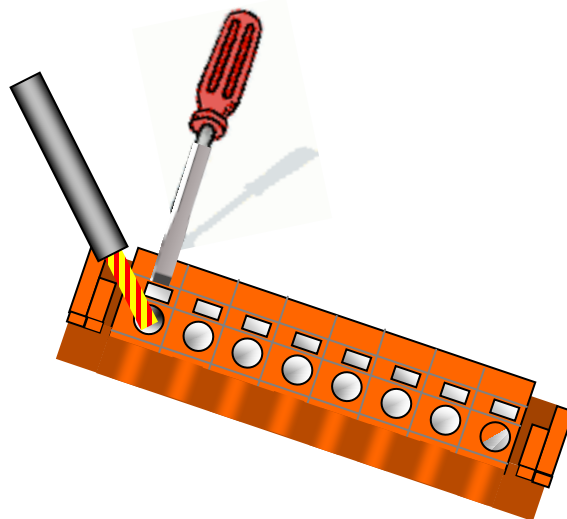

Figure 3-8 Cage Clamp Wire Installation

3.2 USER CONFIGURATION

Configuration of the Communications Manager is accomplished using the LUI (Local User Interface), or the Web UI (Web Browser User Interface). The ECD stores the unit's configuration information into non-volatile memory. The configuration data may also be downloaded via the Web UI or the front panel User USB Port.

3.2.1 Path Selection Modes

The Communications Manager can choose between several physical paths when sending a message to the office system. The Communications Manager provides three modes of determining the office-bound path: primary/backup, redundant, and manual. Figure 3-9 shows the path modes. See Section 4 for Local User Interface and Section 5 for Web Browser and WccMaint Path Selection Mode configuration screens.

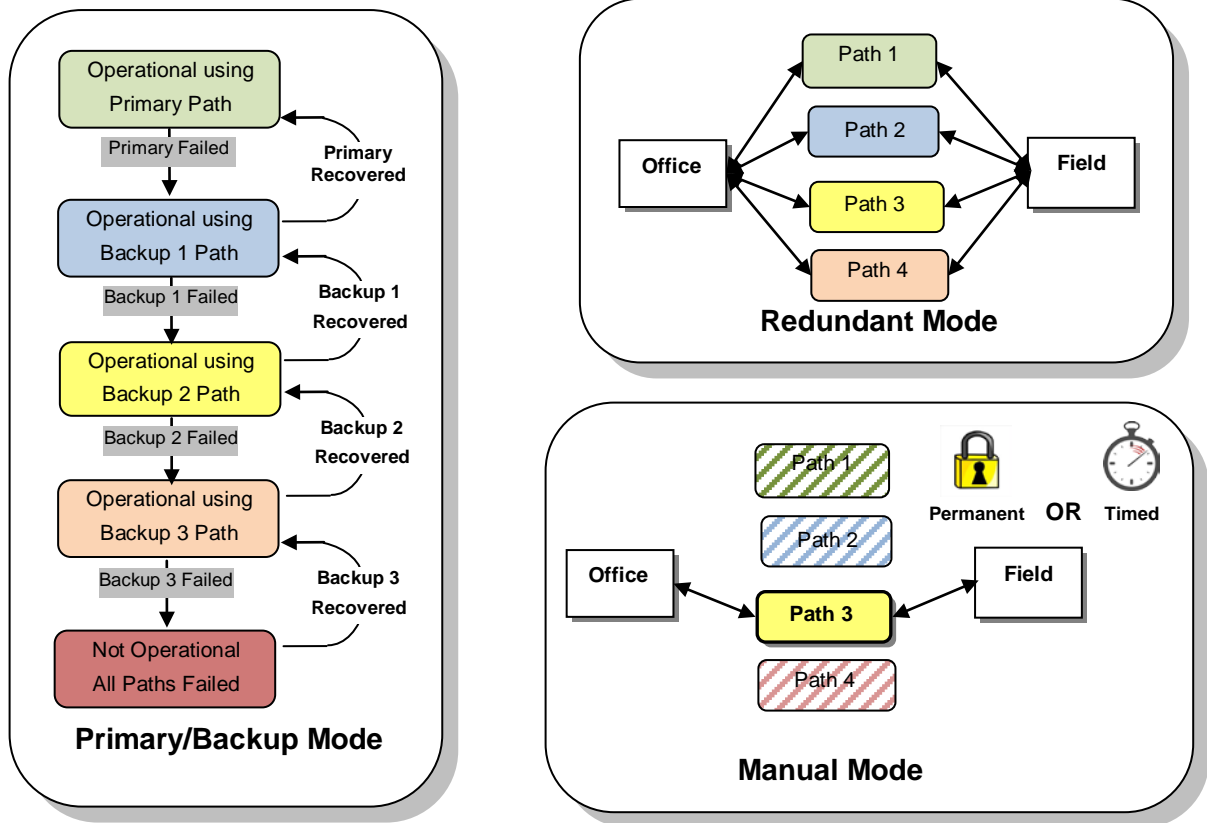

Figure 3-9 Path Modes

3.2.1.1 Primary/Backup Mode

In primary/backup mode, the Communications Manager sends office-bound messages on the most preferred working path. The user chooses which paths are preferred by ranking them as follows (most preferred to least preferred): primary, backup 1, 2, and 3. The Communications Manager will send office-bound packets on the primary path, as long as it remains operational. If the packet cannot be delivered, the Communications Manager will report that path as “failed” and attempt the packet on the next preferred path. See page 3-11 for recommended settings for a WCP as the Primary path and Table 3-1 when WCP is the Backup path.

- **Path Failure**

In primary/backup mode, the Communications Manager considers a path “failed” if an acknowledged packet cannot be delivered on that path after several retries. Any acknowledged packet that cannot be delivered, which includes indications, WAMS alarms, and path test packets, will be used to determine path failure.

The packet’s ATCS priority level, the protocol, and the physical medium determine the time between retries. The Communications Manager uses shorter timeouts for higher priority packets and for Ethernet ports. If the user selected the office path protocol as “Gen/ATCS Field”, the protocol used with the Siemens WCP, the Communications Manager relies on the external equipment to perform retries and report delivery confirmation or delivery failure.

The Communications Manager will also consider a path “failed” if the physical link status of that protocol shows “disconnected”. The specific protocol driver for the port determines the “disconnected” or “connected” state of a physical link. For example, the ATCS HDLC POLL protocol is a polled protocol. If the polling of the port stops, the protocol will report the physical path as failed. If that path is currently the most preferred office path, the Communications Manager will begin using the next most preferred operational path instead.

- **Path Testing**

The Communications Manager can actively test the paths it is not currently using for operational traffic. This allows the Communications Manager to report a path failure before that path may be needed. The user can select how frequently the Communications Manager tests a path. A test packet uses acknowledged service and the Communications Manager will retry a test packet according to the same rules as any acknowledged packet. If the packet does not receive acknowledgement after all retries, the Communications Manager considers the path failed. The Communications Manager also uses path testing to determine when a previously failed path recovers.

- **Path Recovery**

The Communications Manager sends test packets on failed paths to determine when they have recovered. Once a path successfully receives acknowledgement for a test packet, the Communications Manager considers that path “in recovery”. A path must successfully deliver packets for a user selectable amount of time before the Communications Manager will change it from “in recovery” to “operational” status. Once operational, the Communications Manager will begin sending all office-bound traffic on that path if it is now the most preferred.

3.2.1.2 Redundant Mode

In redundant mode, the Communications Manager sends a copy of each packet on all office-bound paths at the same time. Each Path still must be configured as either primary, backup 1, etc. Paths not used are set to "none". The primary versus backup is meaningless for this mode of operation.

An acknowledgement received on any path means that message was successfully sent. Because packets are sent on all paths at the same time and acknowledgements can arrive on any path (usually only one), the paths are not actively tested. The Communications Manager uses the physical link status of the port to determine if a path is operational or failed. If a packet cannot be delivered after several retries on all paths, all paths are considered failed until a packet is successfully delivered. Regardless of the "operational" or "failed" status of a path, the Communications Manager always attempts to deliver a packet on all paths.

3.2.1.3 Manual Mode

When configured for Manual Mode Communications Manager will use a configured path for a configured amount of time, or indefinitely. The path can be configured for Manual Mode using WccMaint from the office, a web browser interface, or the front panel keypad and display. There are two manual mode options: permanent and timed. Manual Mode is typically used to test a specific path for test path reliability or while maintenance is being performed on another path.

- **Permanent**

Upon selecting "permanent" as the manual mode option, the Communications Manager will use the selected office-bound path indefinitely. The "permanent" selection may be cancelled at any time, resulting in Communications Manager reverting back to automatically selecting the office-bound path based on the configured mode (primary/backup or redundant). A system reset will also place the Communications Manager back to automatic mode. If the manually selected path fails for more than five minutes, the system will revert back to automatic mode.

- **Timed Mode**

Upon selecting "timed" as the manual mode option, the Communications Manager will use the configured office-bound path for the configured amount of time. When the time expires, the Communications Manager will revert back to automatically selecting the office-bound path.

3.2.1.4 Path Configuration for WCP

If one of the office paths uses a WCP, the path settings must be adjusted. These adjustments are due to the behavior of the WCP and packet switch.

- 1) A WCP modifies the ATCS layer 3 sequence numbers for office-bound packets in a manner the Communications Manager cannot predict.
- 2) A WCP does not pass through ATCS acknowledgment packets from the office. It generates service signal messages instead, which do not include the ATCS layer 3 sequence numbers from the acknowledgement packet.

- 3) The office packet switch (or OCG) may send an acknowledgement for a packet received from the RF path to a backup path or vice versa. Because the acknowledgements do not pass through, the Communications Manager cannot know if the packet was delivered and the WCP may not receive a RF "ACK" (acknowledge) causing it to incorrectly report that a packet was not delivered.

As a result of the above constraints Communications Manager does not have a reliable method to test a backup path if a WCP is used. If a WCP is used, all backup paths must have the path test period set to 0 to disable the sending of test packets. Paths that are not tested are not marked as failed but as "unknown" when packet delivery fails on them. Using the "unknown" status, the Communications Manager will try those paths again upon failure of other paths.

- **Recommended Settings (when WCP is Primary Path)**

The following are the recommended settings for the primary and the backup path when using a WCP.

Table 3-1 Primary Path: WCP Recommended Settings

Primary Path Setting	Recommended Value	Description
Path Recovery Time	0 (seconds)	Tells the Communications Manager that as soon as the WCP reports a test packet was successfully delivered, it will consider the WCP path as operation and begin using it.
Path Test Period	90 (seconds)	Tells the Communications Manager to send a test packet on the WCP path every 90 seconds. This value should not be set lower than 90 seconds for a WCP path as the RF retries will require about 80-90 seconds for the radio.
Path Fail Count	6	Use the default value. This setting only applies to paths that have an "in recovery" state. Since the path recovery time setting is 0, this setting has no effect.
RSSI Value	0	Tells the Communications Manager not to attach an RSSI value to ATCS packets. The WCP will add its own RSSI value to the packet when it sends the packet on its RF interface.
Operational Traffic Only	No (Unchecked)	Tells the Communications Manager to send all packets, regardless of priority, on the WCP path, if it is the currently selected path.

Table 3-2 Any Backup Path (when a WCP is used as Primary Path)

Backup Path Setting	Recommended Value	Description
Path Recovery Time	300 (seconds)	Use the default value. This setting has no effect since the path will not be tested (Path Test Period set to 0)
Path Test Period	0 (seconds)	Tells the Communications Manager not to send test packets on this path. This is due to the constraints described above when using a WCP. Path failure will not be known in advance.
Path Fail Count	6	Use the default value. This setting has no effect since the path will not be tested (Path Test Period set to 0)
RSSI Value	See Description	See the “Guidelines for RSSI Values” (Section 3.2.1.8) to determine if an RSSI value should be used. If an RSSI value is needed, use a low value such as 1 to ensure the RSSI from the WCP path will be higher than this path’s RSSI.
Operational Traffic Only	No (Unchecked)	Tells the Communications Manager to send all packets, regardless of priority on this path, if it is the currently selected one.

- **Recommended Settings when WCP is Backup Path**

The following are the recommended settings when you use a WCP as a backup path. The WCP must be the last backup path.

Table 3-3 Primary Path (Not a WCP) Recommended Settings

Primary Path Setting	Recommended Value	Description
Path Recovery Time	0 (seconds)	Tells the Communications Manager that as soon as the path successfully delivers a test packet, it will consider the path as operational and begin using it.
Path Test Period	60 (seconds)	Tells the Communications Manager to send a test packet on the path every 60 seconds. This value can be adjusted, to set the desired time Communications Manager will detect path recovery. Since this is not a WCP path, path test periods shorter than 90 seconds are supported. However, this value may need to be adjusted, depending on the protocol/equipment in use.
Path Fail Count	6	Use the default value. This setting only applies to paths that have an “in recovery” state. Since the path recovery time setting is 0, this setting has no effect.
RSSI Value	See Description	See the “Guidelines for RSSI Values” (Section 3.2.1.8) to determine if an RSSI value should be used. If an RSSI value is needed, use a high value such as 61 to ensure the RSSI will be higher than the RF path’s RSSI.
Operational Traffic Only	No (Unchecked)	Tells the Communications Manager to send all packets, regardless of priority, on the path, if it is the currently selected one.

Table 3-4 Backup Path WCP Recommended Settings

Backup Path Setting	Recommended Value	Description
Path Recovery Time	300 (seconds)	Use the default value. This setting has no effect since the path will not be tested (Path Test Period set to 0)
Path Test Period	0 (seconds)	Tells the Communications Manager not to send test packets on this path. This is due to the constraints described above when using a WCP. It means you will not know ahead of time if the path has failed.
Path Fail Count	6	Use the default value. This setting has no effect since the path will not be tested (Path Test Period set to 0)
RSSI Value	0	Tells the Communications Manager not to attach an RSSI value to ATCS packets. The WCP will add its own RSSI value to the packet when it sends the packet on its RF interface.
Operational Traffic Only	No (Unchecked)	Tells the Communications Manager to send all packets, regardless of priority on this path, if it is the currently selected one.

- **WCP and Redundant Mode Restrictions or Constraints**

A WCP cannot be used in a redundant mode system due to the following constraints:

- 1) A WCP modifies the ATCS layer 3 sequence numbers for office-bound packets in a manner the Communications Manager cannot predict.
- 2) A WCP does not pass through ATCS acknowledgment packets from the office. It generates service signal messages instead, which do not include the ATCS layer 3 sequence numbers from the acknowledgement packet.
- 3) The office packet switch (or OCG) may send an acknowledgement for a packet received from the RF path on another path, which forces the WCP to continue retrying packets.

Since the WCP modifies the layer 3 sequence numbers, the duplicate packets received at the packet switch (or OCG) will have different layer 3 sequence numbers. That prevents the packet switch from recognizing that packets are duplicates so it may acknowledge both packets. Since the acknowledgements will be sent by the packet switch on only one of the field-bound paths, the Communications Manager or the WCP may continue to retry the packet.



CAUTION

THIS CREATES A SCENARIO WHERE THE PACKET SWITCH AND/OR THE DISPATCH SYSTEM MAY NOT DETECT STALE PACKETS, WHICH COULD RESULT IN THE DISPATCH SYSTEM DISPLAYING INCORRECT INDICATIONS.

3.2.1.5 Guidelines for ATCS Addressing

The Communications Manager contains several ATCS address settings and the ATCS network requires the field equipment to follow certain rules regarding address assignments. There are two ATCS address types commonly used by the Communications Manager: type 7 wayside addresses and type 2 office addresses.

- **Type 7 Wayside Address Format**

A type 7 wayside address has the following format: **7.RRR.LLL.GGG.SS.DD**. Each field of the address has the following meaning:

RRR	Railroad number between 001 and 999. All equipment installed for the same railroad usually uses the same railroad number.
LLL	Code-line or region number between 1 and 999. The communications system can be broken into lines by the railroad's own internal conventions. The office equipment may have limitations on the number of lines it can manage.
GGG	Group number between 1 and 999. Generally, all the equipment at one location is in the same group. However, there are locations that may require different group numbers set for the devices. The group number must be coordinated between the CTC equipment and the field equipment. The office equipment may have limitations on the number of groups it can support per line.
SS	Subnode number between 1 and 99. Generally, each addressable device at a location has a different subnode number (and the same railroad, line, and group number).
DD	Device number between 1 and 99. Generally used to address a particular device or application within a single piece of equipment. Since the equipment uses the DD for internal addressing, this field is often not user configurable.

The address **7.000.000.000.00.00** can be used as a broadcast address.

The address **7.RRR.000.000.00.00** can also be used as a broadcast address.

- **Type 2 Office Address Format**

A type 2 office address has the following format: **2.RRR.NN.DDDD**. Each field of the address has the following meaning:

RRR	Railroad number between 001 and 999. All equipment installed for the same railroad usually uses the same railroad number.
NN	Network node number between 01 and 99. The office environment can be arbitrarily be broken into several network nodes.
DDDD	Device number between 0001 and 9999. The value is usually used to address specific application in the office. A value of 0000 addresses all applications within the network node.

3.2.1.6 General Address Guidelines

These guidelines apply to any address configured in the system:

- 1) All ATCS addresses should have the same railroad number.
- 2) All type 7 wayside addresses should have the same Code Line number.
- 3) Each wayside device must have a unique ATCS address. Conflicting addresses can cause major communications problems, including the dispatch system displaying incorrect indications.
- 4) If more than one Code Unit is reporting to the Communications Manager, each unit must have a unique ATCS group number.

3.2.1.7 Communications manager Site Address

When assigning a Site Address to the Communications Manager, use the following guidelines:

- 1) The Communications Manager's site ATCS address must be coordinated with the railroad to ensure it is unique.
- 2) If both the Communications Manager and a wayside controller are running ladder logic, the Communications Manager and the wayside controller must each have different group numbers. The office equipment limits handling one indication per group.

3.2.1.8 Guidelines for RSSI Values

The Communications Manager can attach an RSSI value to office-bound packets before sending them. The RSSI value can be set for each office path. The packet switch (and OCG) uses the RSSI values received on each path to determine which path to send field-bound packets on. Not all protocols support attaching RSSI values. Use the following guidelines to determine what number to set in the RSSI value field for each path. See Section 4 for Local User Interface and Section 5 for Web Browser configurations.

- 1) When using the Gen/ATCS Field protocol, the RSSI value should always be set to 0. The WCP or the receiving device will attach its own RSSI value to the packets.
- 2) When using the Genisys Field protocol, the RSSI value has no effect. The Genisys Field protocol does not send ATCS packets.
- 3) If a WCP (RF) is used as a primary path, any backup path where items 1 and 2 do not apply should have a low RSSI value, such as 1. It is recommended for the backup path to have a lower RSSI than the RF path, which will ensure the packet switch (or OCG) prefers to send field-bound packets out RF.
- 4) If a WCP (RF) is used as a backup path, more preferred paths where items 1 and 2 do not apply should have a high RSSI, such as 61. It is recommended for the primary path to have a higher RSSI than the RF path, which will ensure the packet switch (or OCG) prefers the primary path over the RF path.
- 5) If all previous guidelines do not apply, the path should have a lower RSSI value than paths more preferred. In this case use a path's default RSSI value. The default RSSI values are as follows: primary = 61, backup1 = 51, backup2 = 41 and backup3 = 31.

3.2.1.9 Site Setup Configuration Options

The Table lists the Site Setup Configuration Options.

Table 3-5 Site Setup Configuration Parameters

Parameter	Range	Default
Site Name	1 - 20 Characters	Safetran Systems
Milepost	0 - 20 Characters	000.0
DOT Number:	1 - 7 Characters	000000A
Time zone:	GMT, EASTERN, CENTRAL, MOUNTAIN, PACIFIC, ALASKA, ATLANTIC, ARIZONA (NO DST), NEWFOUNDLAND, AUS WESTERN, AUS CENTRAL, AUS CNTRL (NO DST), AUS EASTERN, AUS EASTERN (NO DST)	EASTERN
Site ATCS Address	7.000.000.000.00 - 7.999.999.999.99	7.620.100.100.01
CAD Address	2.000.00.0000 - 2.999.99.9999	2.620.00.0000
WAMS Address	2.000.00.0000 - 2.999.99.9999	2.620.01.9100
WAMS System	Enabled or Disabled	Enabled
Path Selection Mode	Primary/Backup Redundant	Primary/Backup
Indication Refresh Period	0 (no refresh) - 600 seconds	60 seconds
Indication Holdoff	0 (no holdoff) - 10 seconds	0 seconds

3.2.1.10 Serial Port Configuration Options

The following table summarizes the protocol options for the serial ports. If the "Field" path is selected only field options will display, likewise if the "Office" path is selected, only the office options will display. If no path is selected ("None") no path information will appear.

Table 3-6 Serial Port Configuration Summary

Path Type	Protocol	Clock Mode	Line Modes	TX Clock
Field	Genisys Office	Async	RS-232 Only	N/A
Field	Gen/ATCS Office	Async	RS-232 Only	N/A
Field	CN2000A	Async	RS-232 Only	N/A
Field	CN2000B	Async	RS-232 Only	N/A
Field	Dumb Terminal	Async	RS-232 Only	N/A
Field	Diagnostic Text	Async	RS-232 Only	N/A
Field	BCM Diag	Async	RS-232 Only	N/A
Field	ATCS/HDLC ADM	Sync	RS-232 or RS-422*	Internal or External
Field	ATCS/HDLC UI	Sync	RS-232 or RS-422*	Internal or External
Office	Genisys Field	Async	RS-232 Only	N/A
Office	Gen/ATCS Field	Async	RS-232 Only	N/A
Office	ATCS/HDLC POLL	Sync	RS-232 or RS-422*	Internal or External

* The 2 partial-featured serial ports only support Async protocols and RS-232 Line Mode.

Table 3-7 Serial Ports 1 – 4 Parameters

Parameter	Range	Default
Baud Rate	1200, 2400, 4800, 9600, 19200, 38400, 57600, or 115200	9600
Data Bits	7 or 8	8
Parity	None, even, or odd	None
Stop Bits	1 or 2	1
Flow Control	None or Hardware	None
Path Type	None, Field, Office Primary, Office Backup 1, Office Backup 2, or Office Backup 3	None

Table 3-8 Full-featured Port – Path Type: FIELD

Parameter	Range	Default
Protocol	Gen/ATCS Office, Genisys Office, ATCS/HDLC ADM, ATCS/HDLC UI, CN2000A, CN2000B, Dumb Terminal, Diagnostic Text, BCM Diag	Gen/ATCS Office

Table 3-9 Partial-featured Port – Path Type: FIELD

Parameter	Range	Default
Protocol	Gen/ATCS Office, Genisys Office, CN2000A, CN2000B, Dumb Terminal, Diagnostic Text, BCM Diag	Gen/ATCS Office

Table 3-10 Full-featured Port – Path Type: Office Primary, Office Backup 1, 2, or 3

Parameter	Range	Default
Protocol	Gen/ATCS Field, Genisys Field, ATCS/HDLC POLL	Gen/ATCS Field

Table 3-11 Partial-featured Port – Path Type: Office Primary, Office Backup 1, 2, or 3

Parameter	Range	Default
Protocol	Gen/ATCS Field, Genisys Field,	Gen/ATCS Field

Table 3-12 Full-featured Port – Protocol: ATCS/HDLC ADM, UI, or POLL

Parameter	Range	Default
Line Mode	RS-232, RS-422	RS-232
TX Clock Source	Internal, External	Internal

NOTE

NOTE

The Communications Manager uses Async Clock Mode and RS-232 Line Mode for all Async protocols: Genisys Office, Genisys Field, Gen/ATCS Office, Gen/ATCS Field, CN2000A, CN2000B, Dumb Terminal, Diagnostic Text, and BCM Diag.

Table 3-13 Laptop Serial Port Options

Parameter	Range	Default
Baud Rate	1200, 9600, 57600, or 115200	9600
Data Bits	7 or 8	8
Parity	None, even, or odd	None
Stop Bits	1 or 2	1
Flow Control	None or Hardware	None

3.2.1.11 Ethernet Port Configuration Options

The following are the Ethernet port configuration parameters:

Table 3-14 Ethernet Port Options

Parameter	Range	Default
DHCP Client	Enabled or Disabled	Disabled
Path Type	None, Field, Office Primary, Office Backup 1, Office Backup 2, or Office Backup 3	None

Table 3-15 Ethernet Port Options – DHCP Client Disabled

Parameter	Range	Default
IP Address	0.0.0.0 - 255.255.255.255	192.168.X.1 where X is replaced with the Port number plus one. (Ethernet Port 2 default would be 192.168.3.1).
Network Mask	0.0.0.0 - 255.255.255.255	255.255.255.0
Default Gateway	0.0.0.0 - 255.255.255.255	192.168.X.1 where X is replaced with the Port number plus one. (Ethernet Port 2 default would be 192.168.3.1).

Table 3-16 ATCS/IP Office Options

Parameter	Range	Default	Description
OCG Circuit ID	0.0.0 - 999.2.15	620.1.1	The circuit ID, or base ID, of every IP base belonging to this HUB is manually entered here along with its IP address. The base ID is an assigned 16-bit value that is used as a unique tag for each base.
Routing Region One	0.0.0.0 - 255.255.255.255 or Symbolic Name	192.168.X.2 where X is replaced with the Port Number plus one.	This can be either a subnet broadcast or unicast IP address associated with office OCG or packet switch.
Routing Region Two	0.0.0.0 - 255.255.255.255 or Symbolic Name	192.168.X.3 where X is replaced with the Port Number plus one.	This can be either a subnet broadcast or unicast IP address associated with office OCG or packet switch.
OCG Port	0 - 65535	5361	Specifies the port number used to listen for messages. Specifies the UDP port number used to listen for messages. Default is 5361.
Path Value	0 - 255	72	This is information used by packet switch/OCG to specify inbound path options such as main/standby, field device operation, etc.
Route Search Time	0 - 65535 seconds	15 Seconds	Route request is sent per this time interval until a route update response is received.
Route Search Tries	0 - 255	4	The number of times Communications manager will retry a route search if a response is not received.
Route Refresh Time	0 - 65535 Minutes	5 Minutes	Once a route update response is received, a route request is periodically sent per this time interval to refresh the route table.

3.2.1.12 DNS Options

The following are the configurable DNS protocol options:

Table 3-17 DNS Options

Parameter	Range	Default	Description
Nameserver 1	0.0.0.0 - 255.255.255.255	192.168.2.1	IP address of DNS server
Nameserver 2	0.0.0.0 - 255.255.255.255	192.168.3.1	IP address of DNS server
Nameserver 3	0.0.0.0 - 255.255.255.255	192.168.4.1	IP address of DNS server

3.2.1.13 Echelon® Options

The following are the configurable Echelon® options.

Table 3-18 Echelon® Configuration Options

Option	Range	Default	Description
Gateway Node	1 -126	1	If the destination ATCS address of a message to send on Echelon® is not part of the same group as the Communications Manager, it sends the ATCS message to this Echelon® Node.

3.2.1.14 Gen/ATCS Field Protocol Options

Each port configured for Gen/ATCS Field Protocol will have the following configuration options:

Table 3-19 Gen/ATCS Field Protocol Options

Option	Range	Default	Description
Poll Address	1 - 254	1	
Link Fail Timer	250 - 60000 milliseconds	1000 ms	This is used as a watchdog timer to time the receipt of Genisys Office messages.
Comms Device Addr (for setting WCP address via XID)	7.000.000.000.00.00 (disabled) 7.999.999.999.99.99	7.000.000.000.00.00 (disabled)	This address is used when building an XID message. The external equipment will read the address from the XID message and assign itself that address. If it is left at 7.000.000.000.00.00, the external equipment will not use the address and will use its own assigned address instead.

3.2.1.15 Gen/ATCS Office Protocol Options

Each port configured for Gen/ATCS Office Protocol will have the following configuration options:

Table 3-20 Gen/ATCS Office Protocol Options

Option	Range	Default	Description
Polling Range Start	1 - 254	1	The first Genisys station number in the polling sequence
Number of Stations	1 - 24	1	The number of stations to poll.
Short Poll Delay	250 - 120000 milliseconds	1000 ms	The amount of time to wait for a poll response when the station is online.
Long Poll Delay	250 - 120000 milliseconds	10000 ms	The amount of time to wait for a poll response when the station is offline.
Retry Count	0 - 255	5	The number of times to send a data frame to the field code unit before discarding the frame.
Response Fail Count	0 - 255	Not Used	

3.2.1.16 Genisys Office Protocol Options

Each port configured for Gen/ATCS Office Protocol will have the following configuration options:

Table 3-21 Gen/ATCS Office Protocol Options

Option	Range	Default	Description
Polling Range Start	1 - 254	1	The first Genisys station number in the polling sequence
Number of Stations	1 - 24	1	The number of stations to poll.
Short Poll Delay	250 - 120000 milliseconds	1000 ms	The amount of time to wait for a poll response when the station is online.
Long Poll Delay	250 - 120000 milliseconds	10000 ms	The amount of time to wait for a poll response when the station is offline.
Retry Count	0 - 255	5	The number of times to send a data frame to the field code unit before discarding the frame.
Source ATCS Address	7.RRR.LLL.GGG.SS.DD	5	The base ATCS address that will be used as the source address for each station. The station number that responded to a poll is added to the GGG field to create a source ATCS address.

3.2.1.17 ATCS/HDLC ADM Options

The ATCS/HDLC ADM protocol must be configured on the full-featured serial ports. Each port will have the following configurable options.

Table 3-22 ATCS/HDLC ADM Configurable Options

Option	Range	Default	Description
Message Response Timer	300 - 65535 milliseconds	1000 milliseconds	Used for timing an expected response message.
Retry counter	0 - 255	3	Number of times to retry a transmitted message.
Line Mode	RS-232 or RS-422	RS-232	
TX Clock Source	Internal or External	Internal	

3.2.1.18 ATCS/HDLC UI Options

ATCS/HDLC UI interfaces with the base station controller equipment (such as BCM or BCM II). In this application Communications Manager polls the base station controller. The following table displays the user configurable options to the Office System.

Table 3-23 ATCS/HDLC UI Configurable Options

Parameter	Range	Default	Description
Message Response Timer	300 - 65535 milliseconds	1000 milliseconds	Used for timing an expected response message.
Retry counter	0 - 255	3	Number of times to retry a transmitted message.
First Station Number	1 - 255	1	The first station number in the polling sequence.
Number of Stations	1 - 15	1	The number of stations to poll.
Line Mode	RS-232 or RS-422	RS-232	
TX Clock Source	Internal or External	Internal	

3.2.1.19 ATCS/HDLC POLL Options

The ATCS/HDLC POLL protocol interfaces directly with packet switches in the office. The following table lists the user configurable options.

Table 3-24 ATCS/HDLC POLL Configurable Options

Parameter	Range	Default	Description
Message Response Timer	300 - 65535 milliseconds	1000 milliseconds	Used to time an expected message from the packet switch.
Retry counter	0 - 255	3	Number of times to retry a transmitted message
Poll Address	1 - 15	1	The poll address that will be responded to.
Line Mode	RS-232 or RS-422	RS-232	
TX Clock Source	Internal or External	Internal	

3.2.1.20 Office Path Options

Each Ethernet port and serial port configured as an office path (Office Primary, Office Backup1, 2, or 3) has the following user configurable options as shown in the table below.

Table 3-25 Office Path Configurable Options Primary Office and Backup

Option	Range	Default	Description
Path Recovery Time	0 - 3600 seconds	300 seconds	The amount of time a path must successfully deliver messages with no losses before the path can be considered "Operational" again.
Path Test Period	0 - 7 Days	60 seconds	The time between attempts to send a test packet on a path's whose state is either "Failed", "In Recovery", or "Operational" (not currently the most preferred path), If the "Path Test Period" is set to zero the path will not be tested. A test period of zero should only be configured for the least preferred path.
Path Fail Count		6	The minimum number of test packets that do not receive a response, causing a path to change from "In Recovery" to "Failed" state.
RSSI Value		61 - Office Primary 51 - Office Backup 1 41 - Office Backup 2 31 - Office Backup 3	Defines the RSSI value the office protocol will attach to the end of all ATCS RF_INFO packets transmitted on an office path. If the user sets the value to 0, the Communications Manager will not attach an RSSI value.

3.2.1.21 CN2000A & CN2000B Protocols

The CN2000A and CN2000B protocols operate with the CN2000 wayside controller equipment. The following table displays the user configurable options.

Table 3-26 CN2000A & CN2000B Configurable Options

Option	Range	Default	Description
Polling Range Start	1 - 254	1	The first station number to poll.
Number of Stations	1 - 24	1	The number of CN2000 Code Units to poll.
Short Poll Delay	250 - 60000 milliseconds	1000 ms	The time interval between sending poll
Long Poll Delay	250 - 120000 milliseconds	10000 ms	The wait time for an indication acknowledge to be received from packet switch or OCG.
Source ATCS Address	7.RRR.LLL.GGG.SS.DD	7.620.100.100.01.01	The source ATCS address to use as the address of the field stations. The polled station number replaces the GGG field

3.2.1.22 Dumb Terminal Options

Each port configured for Dumb Terminal will have the following options appear:

Table 3-27 Dumb Terminal Parameters

Parameter	Range	Default	Description
SSH Port Number	0 - 65535	10021 for Serial Port 1 10022 for Serial Port 2 10023 for Serial Port 3 10024 for Serial Port 4	The TCP port number the driver listens on for the new SSH connections
Session Time-out	0 - 60 minutes Value of 0 disables time-out	10 minutes	The amount of time of no received data before the session is disconnected

3.2.1.23 Diagnostic Text Options

Each port configured for Diagnostic Text will have the following options appear:

Table 3-28 Diagnostic Text Parameter Options

Parameter	Range	Default	Description
SSH Port Number	0 - 65535	10021 for Serial Port 1 10022 for Serial Port 2 10023 for Serial Port 3 10024 for Serial Port 4	The TCP port number the driver listens on for the new SSH connections
Session Time-out	0 - 60 minutes Value of 0 disables time-out	10 minutes	The amount of time of no received data before the session is disconnected

3.2.1.24 Digital Input Options

The Communication Manager Digital Inputs have the following configuration parameters:

Table 3-29 Digital Input Configuration Options

Parameter	Range	Default	Description
Input Name	0 - 10 Characters	Input X	(Where X is the input number).
Algorithm	Discrete or GFT	Discrete	

- **Digital Inputs - Algorithm: Discrete**

The following configuration parameters appear when Algorithm is set for Discrete:

Table 3-30 Digital Inputs – Algorithm: Discrete

Parameter	Range	Default	Description
Off State Name	0 - 10 Characters	Off	Up to 10 characters in length and used to identify Off state.
On State Name	0 - 10 Characters	On	Up to 10 characters in length and used to identify On state.
Toggle State Name	0 - 10 Characters	Toggling	Up to 10 characters in length and used to identify Toggle state.
Off De-bounce	0 - 60000 milliseconds	100 ms	Number of milliseconds an input must be de-energized before it is declared OFF.
On De-bounce	0 - 60000 milliseconds	100 ms	Number of milliseconds an input must be energized before it is declared ON.
Toggle Period	0 - 60000 milliseconds	1000 ms	Number of milliseconds within an input changing state 4 or more times is declared TOGGLING.

- **Digital Inputs - Algorithm: GFT (Ground Fault Detector)**

The following configuration parameters appear when Algorithm is set for GFT:

Table 3-31 Digital Inputs – Algorithm GFT

Parameter	Range	Default	Description
Battery 1 Name	0 - 10 Characters	BAT 1	0-10 characters (Where X is the input number).
Battery 2 Name	0 - 10 Characters	BAT 2	0-10 characters (Where X is the input number).

3.2.1.25 Analog Input Options

The following are the configurable parameters for the Analog Input ports:

Table 3-32 Analog Input Options

Parameter	Range	Default	Description
Name	0 - 10 Characters	Batt X	0-10 characters (Where X is the input number).
Resolution	0.1V to 36.0V	0.5V	Specifies the change in voltage required before an event will be logged into the Argus event log. The voltage is calculated as the average of the number "Samples to Average".
Sample Period	100 - 60000 milliseconds	100 ms	Number of milliseconds between raw samples of the input. The average of the last "Samples to Average" readings is taken at this point and compared to the last logged value to determine if a new event needs to be logged.
Average Count	1 - 64 samples.	10	Specifies the number of consecutive samples to average together to determine the voltage present on the input. A list of the last "Samples to Average" samples is kept as the voltage readings are taken. At each sample period, the list of voltage readings is averaged together to determine the voltage value.
Re-read Period	0 - 60000 milliseconds	500 ms	The number of milliseconds after an event is logged, when one more comparison of voltage to the last logged value will be taken. This function has a default value of 500 ms.
Re-read Resolution	0.0V (off) to 36V.	0.2V	The voltage difference required to log another event after the re-read comparison is performed. This function has a default value of 0.2 VDC.

3.2.1.26 Relay Output Options

The following are the configurable parameters for the Relay Outputs:

Table 3-33 Relay Output Options

	Range	Default	Description
Name	0 - 10 Characters	Relay X	0-10 characters (Where X is the output number).
Off State Name	0 - 10 Characters	Off	Up to 10 characters in length and used to identify OFF state.
On State Name	0 - 10 Characters	On	Up to 10 characters in length and used to identify ON state.
Toggle State Name	0 - 10 Characters	Toggling	Up to 10 characters in length and used to identify TOGGLE state.
Toggle Period	500 - 60000 milliseconds	1000 ms	Number of milliseconds within an input changing state 4 or more times is declared TOGGLING.
Duty Cycle	0 - 100 percent	50%	Percentage of time in ON state.

3.2.1.27 Diagnostic Logging Options

The Diagnostic Log has configurable parameters for logging message traffic. The following table displays the parameters available.

Table 3-34 Diagnostic Logging Options

Parameter	Range	Default	Description
Message Processing Logging (Layer 7)	Enabled or Disabled	Disabled	Logs messages addressed to and generated by the Communications Manager unit. The ATCS packet header information is not shown; only the application layer data of the message is shown. For multi-part messages, the data is logged after the re-assembly of all the received message parts and before breaking up sent messages.
Routing Logging (Layer 3)	Enabled or Disabled	Disabled	Logs messages handled by the internal ATCS router. The router handles ATCS layer 3 packets and all data including the ATCS layer 3 header is shown in the log entries. The router determines what to do with received messages and handles path selection.
Serial Port 1 RX/TX Logging (Layer 2)	Enabled or Disabled	Disabled	Logs data link layer message data as it is sent and received using the selected serial protocol.
Serial Port 2 RX/TX Logging (Layer 2)	Enabled or Disabled	Disabled	Logs data link layer message data as it is sent and received using the selected serial protocol.
Serial Port 3 RX/TX Logging (Layer 2)	Enabled or Disabled	Disabled	Logs data link layer message data as it is sent and received using the selected serial protocol.
Serial Port 4 RX/TX Logging (Layer 2)	Enabled or Disabled	Disabled	Logs data link layer message data as it is sent and received using the selected serial protocol.
Ethernet Port 1 RX/TX Logging (Layer 2)	Enabled or Disabled	Disabled	Logs data link layer message data as it is sent and received using the selected Ethernet protocol.
Ethernet Port 2 RX/TX Logging (Layer 2)	Enabled or Disabled	Disabled	Logs data link layer message data as it is sent and received using the selected Ethernet protocol.
Ethernet Port 3 RX/TX Logging (Layer 2)	Enabled or Disabled	Disabled	Logs data link layer message data as it is sent and received using the selected Ethernet protocol.
Ethernet Port 4 RX/TX Logging (Layer 2)	Enabled or Disabled	Disabled	Logs data link layer message data as it is sent and received using the selected Ethernet protocol.

3.2.1.28 GPS Configuration Options

The following table displays the user configurable parameters and descriptions for the GPS receiver.

Table 3-35 GPS Configuration Options

Option	Range	Default	Description
Sats For Time	1 - 4	4	The number of satellites that must be in view before the Communication Manager will set its date/time from the GPS receiver's date/time information.
Time Difference	1 - 300 seconds	5 seconds	The number of seconds the GPS receiver's date/time and the system's present date/time must differ before the Communications Manager will set the date/time from the GPS date/time.

NOTE

NOTE

The GPS feature is no longer available in Communications Manager Model 53475 Revision C3 or later.

3.2.1.29 SNMP Traps

Communications Manager is equipped to send alarms generated by an application as SNMP version 2 traps. The trap is generated by application program, (if it is an IP path). The ATCS address, Site Name, Milepost, DOT, and Date/Time will automatically be filled in. The application-assigned alarm number, Application-assigned alarm text, Application-defined SNMP alarm number, and Application-defined SNMP severity level will be filled in from the application, run by the CDL engine.

The following table displays the user configurable SNMP Trap options.

Table 3-36 SNMP Trap Configurable Options

Option	Range	Default	Description
Primary Destination IP	0.0.0.0 (disabled) - 255.255.255.255 or symbolic name	0.0.0.0 (disabled)	The destination IP address to send SNMP traps when the currently active path is primary.
Primary Destination Port	0 - 65535	162	The destination IP Port Number to send SNMP Traps when the currently active path is primary.
Backup 1 Destination IP	0.0.0.0 (disabled) - 255.255.255.255 or symbolic name	0.0.0.0 (disabled)	The destination IP address to send SNMP traps when the currently active path is backup 1.
Backup 1 Destination Port	0 - 65535	162	The destination IP Port Number to send SNMP Traps when the currently active path is backup 1.
Backup 2 Destination IP	0.0.0.0 (disabled) - 255.255.255.255 or symbolic name	0.0.0.0 (disabled)	The destination IP address to send SNMP traps when the currently active path is backup 2.
Backup 2 Destination Port	0 - 65535	162	The destination IP Port Number to send SNMP Traps when the currently active path is backup 2.
Backup 3 Destination IP	0.0.0.0 (disabled) - 255.255.255.255 or symbolic name	0.0.0.0 (disabled)	The destination IP address to send SNMP traps when the currently active path is backup 3.
Backup 3 Destination Port	0 - 65535	162	The destination IP Port Number to send SNMP Traps when the currently active path is backup 3.

- **Disabling SNMP Traps**

SNMP Traps can be disabled by setting the Destination IP addresses to the default value (0.0.0.0).

3.2.1.30 WSA/S2

Communications Manager is equipped to interface with Westrace Freight

The following table displays the user configurable parameters for Westrace Freight interface.

Table 3-37 WSA/S2 Parameters

Parameter Name	Range	Default	Description
WSA/S2 Enabled	Yes or No	No	Set to Yes to enable the WSA/S2 protocol functions.
WSA/S2 UDP Port	0..65535	3800	The UDP port number used to send and receive WSA/S2 messages.
WSA/S2 Destination IP	<IPv4 Address>	192.168.1.1	The IP address of the Westrace Freight unit.
Session ID	1..255	1	An identifier associated with the session. Must match the ID provided in WTRF.
Address ID	1..62	1	The WSA/S2 address of the WTRF.
Loss of Comms Timeout	100..30000 (ms) in 100 ms increments	5000 (ms)	If no WSA/S2 messages are received within this timeout, the Comms Manager will declare the session as "failed".
Transmit Rate	100..30000 (ms) in 100 ms increments	1000 (ms)	The rate at which the Comms Manager will transmit WSA/S2 control messages to the destination system.
Input Offset	0..28	0	Offset, in bytes, into the input logic states ("I" bits) of the ladder logic bitmap to copy the received WSA/S2 logic states.
Input Size	4, 6, 8, 12, 16, or 32	4	The size, in bytes, of data to copy from the received WSA/S2 logic states. Selected from drop down menu.
Output Offset	0..28	0	Offset, in bytes, into the output logic states ("O" bits) of the ladder logic bitmap to copy the sent WSA/S2 logic states.
Output Size	4, 6, 8, 12, 16, or 32	4	The size, in bytes, to copy the sent WSA/S2 logic states. Selected from drop down menu.

SECTION 4

WEB USER INTERFACE (WebUI)

4.0 WEB USER INTERFACE (WEBUI)

4.1 GENERAL

The Communications Manager comes with a Web Interface which enables users to configure the system as well as monitor system status using any web browser. Access can be via a network or locally using the Ethernet port on the front panel. Access is protected by a username and password.

4.2 USER COMPUTER SETUP

Setting up a computer to connect with the Communications Manager follows standard fundamental LAN protocol. The User Ethernet Port defaults as a DHCP Server. Setting the computer as a DHCP client will enable the Communications Manager to assign the computer an IP address. The user can also manually set up the computer's TCP/IP properties (e.g. IP address 192.168.1.105, subnet as 255.255.255.0) to connect with the Communications Manager as shown in the figure below. The example shown is for Windows XP and varies between Windows versions (Vista, Windows 7). This procedure is **NOT** necessary unless the intent is to set up the computer's Ethernet port to something other than a default configuration.

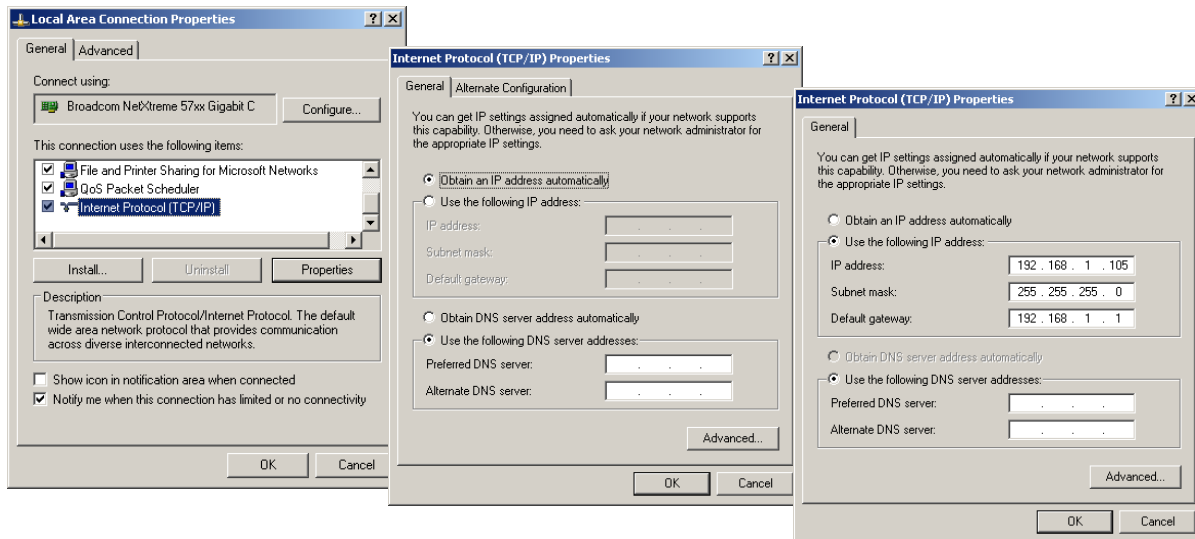

Figure 4-1 User Computer Setup

4.3 STARTING THE WEB USER INTERFACE (WEBUI)

To access the Communications Manager, enter "https://" and the unit's IP Address in the browser address window as shown in Figure 4-2. It is necessary to preface the IP address with "https://". The front panel Ethernet port's default address is 192.168.1.100.

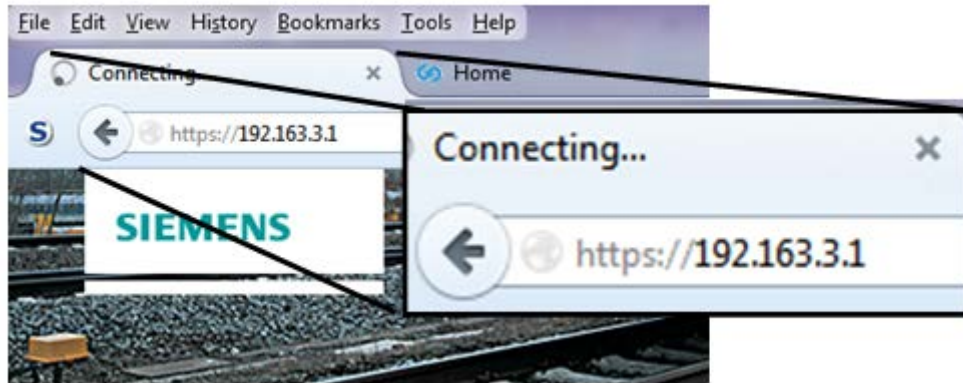

Figure 4-2 Communications Manager Web User Interface Start Up

4.3.1 Web Login

The WebUI's opening page will appear as shown below. Click on either **Login** highlighted to bring up the login screen.

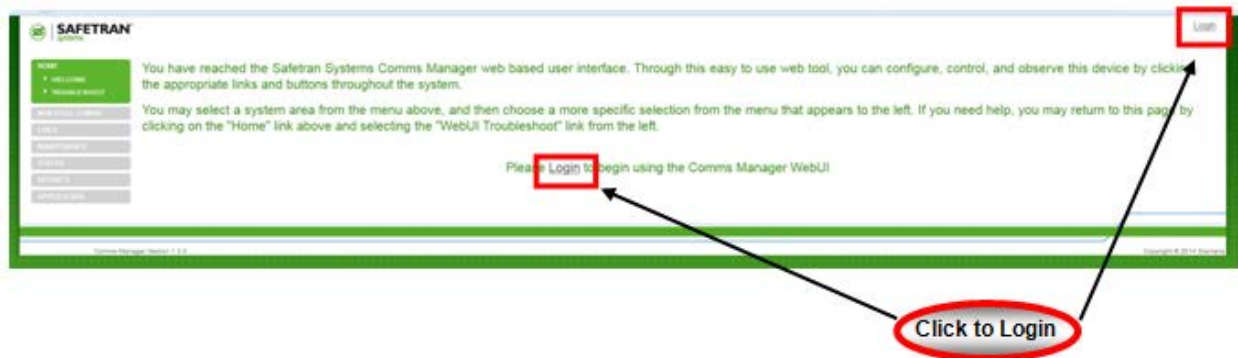

Figure 4-3 WebUI Opening Screen

The WebUI's Login Page will appear. Enter the appropriate **Username** and **Password**, and then click on the **Login** button

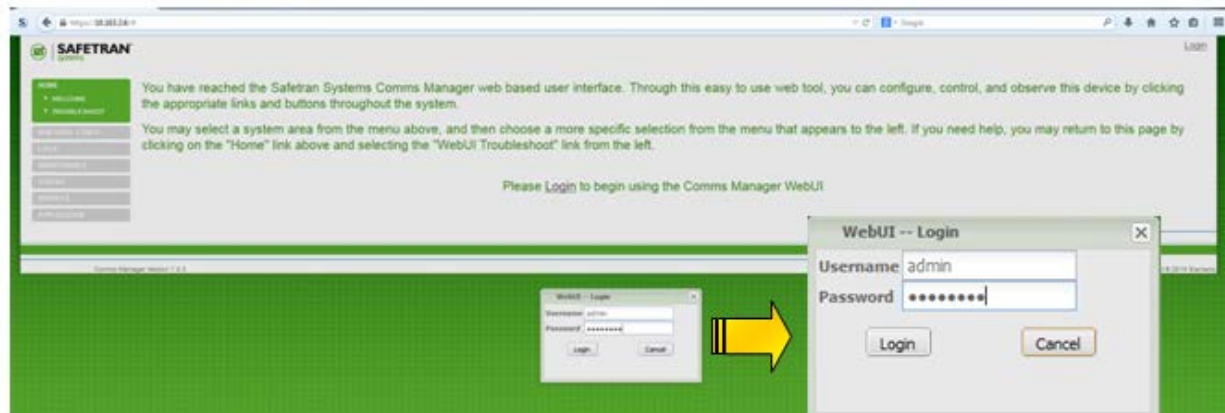

Figure 4-4 WebUI Login Page

The login confirmation can be viewed in two locations. A pop up window will appear briefly to verify the User Name and Password was accepted. Login status is also continuously displayed in the upper right corner and includes Logout interactive text to conclude the session.



Figure 4-5 WebUI Login Confirmation

4.3.2 Web UI Welcome Page

The WebUI's Welcome Page will appear, as displayed in Figure 4-6. To the left of the page is the **Web UI Navigation Menu**. Each menu item has a list of sub-menu items. The Site Information is listed on the top of the page for easy reference. Login status is listed on the upper right corner of the page.

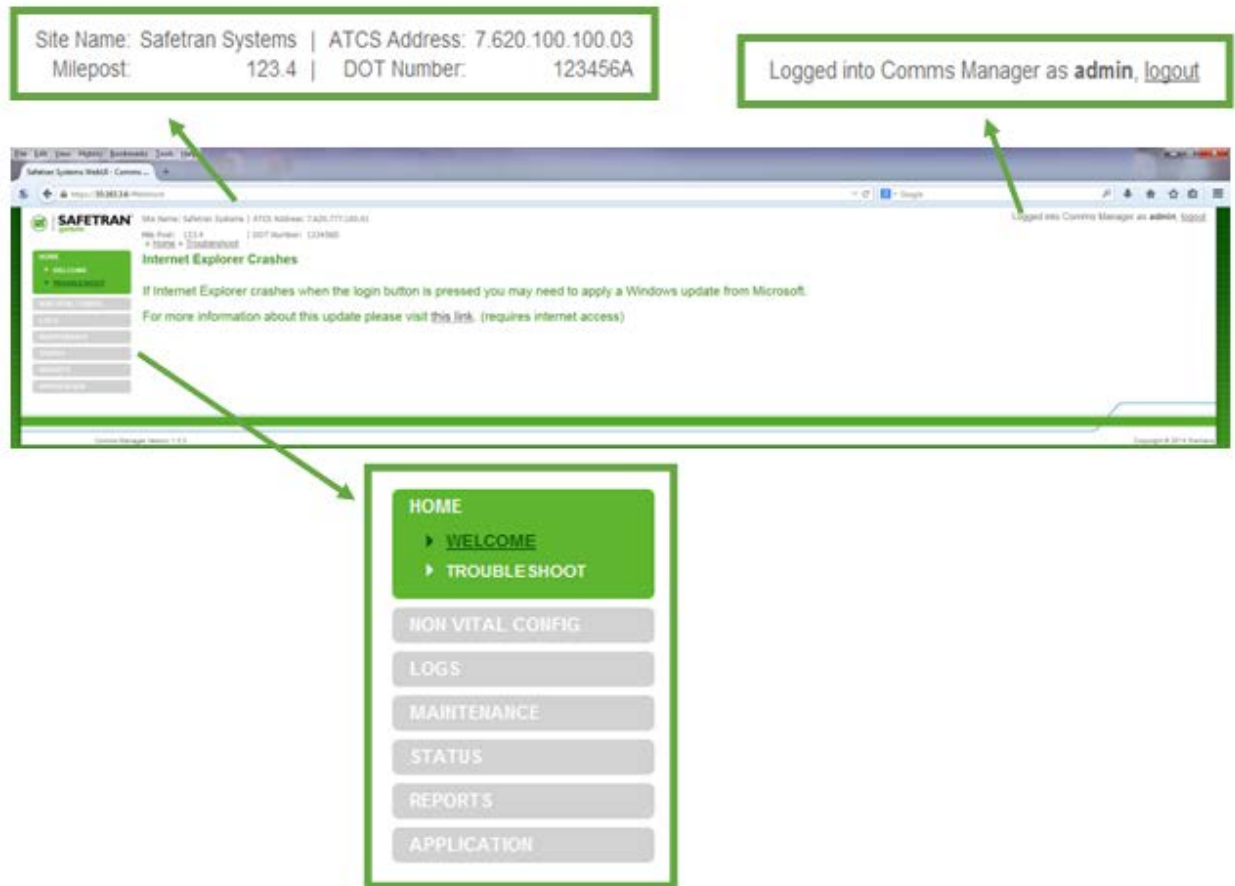

Figure 4-6 WebUI Welcome Page

4.3.3 WebUI Troubleshooting

In the unlikely event of an Internet Explorer failure, an application download is available via the Internet. Click on the **Troubleshoot** interactive text to bring up the Troubleshooting page as shown in Figure 4-7.

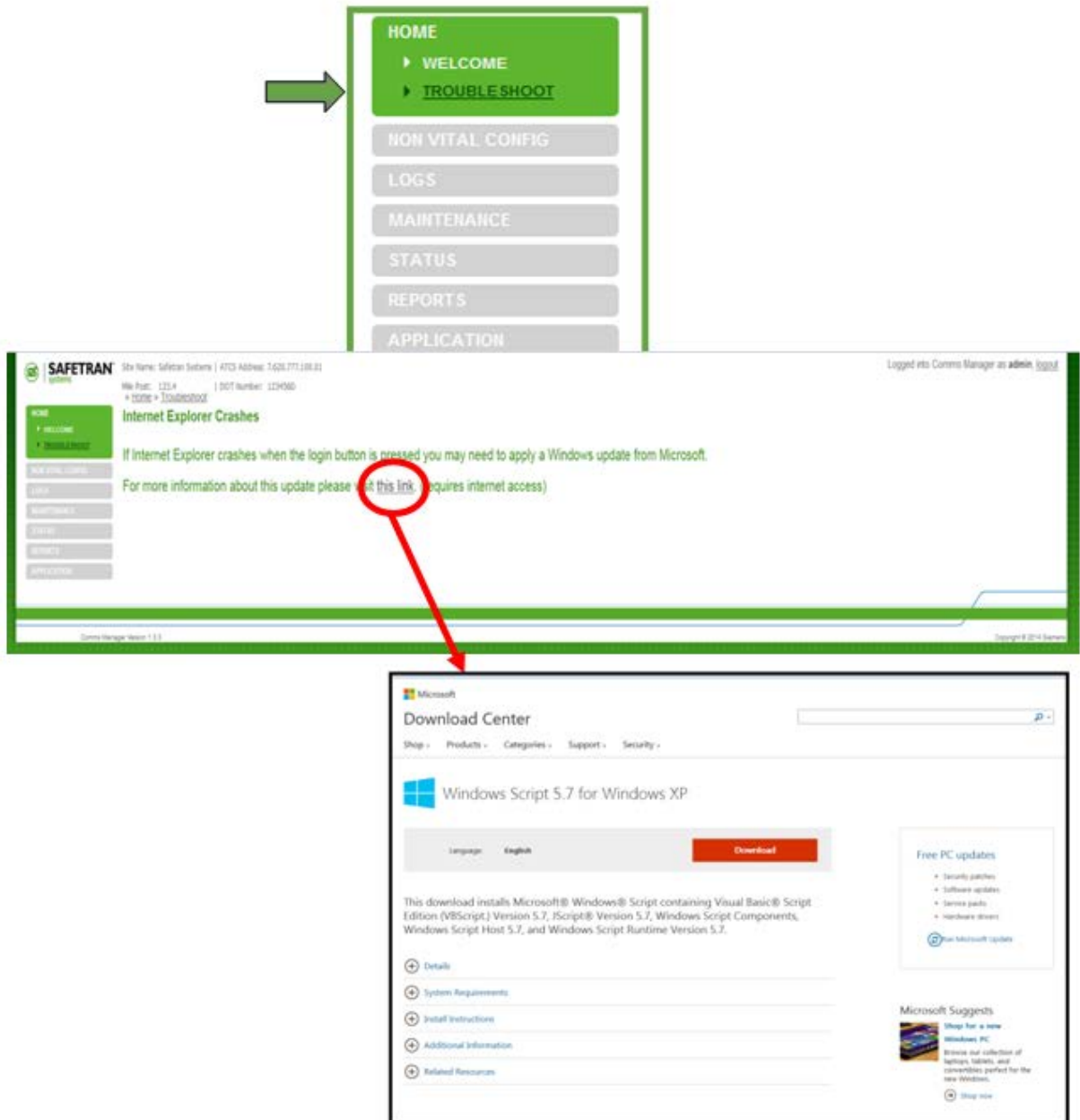

Figure 4-7 Troubleshooting Page

4.3.4 Non-Vital Configuration

The WebUI is one method to configure the Communications Manager. The WebUI navigation menu shows a list of configuration sub-menus as shown in Figure 4-8.

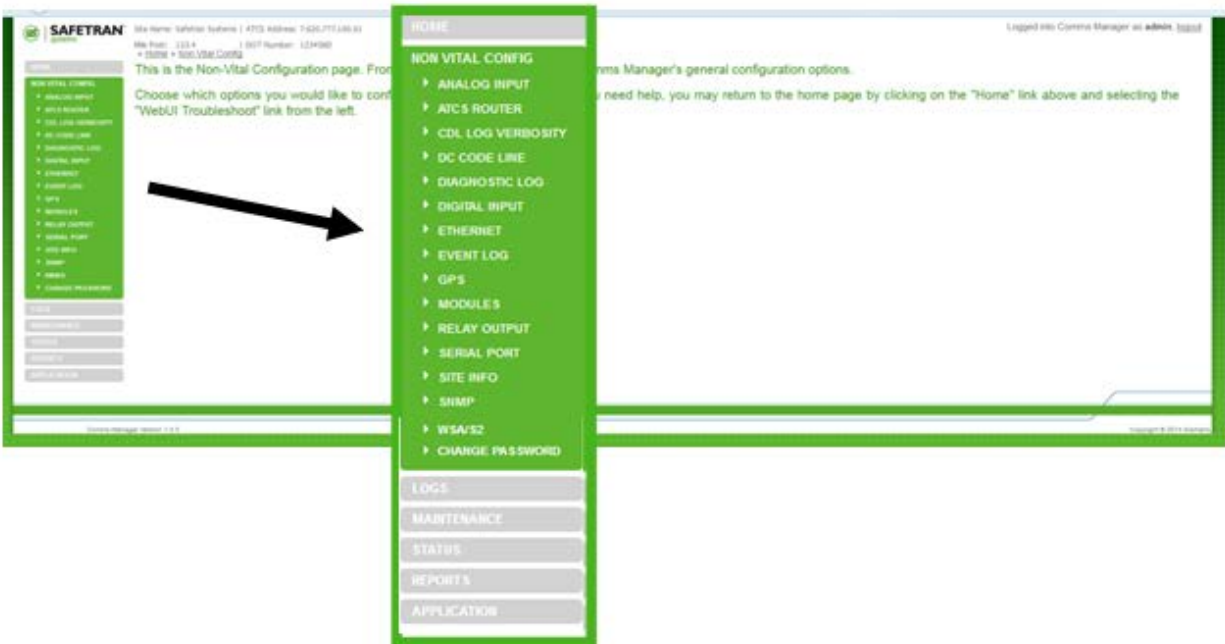

Figure 4-8 Non-Vital Configuration Menu

4.3.4.1 Analog Input

Click on the **Analog Input**, from the list of configuration sub-menus to bring up the Analog Input Configuration Page.



Figure 4-9 Configuration Menu – Analog Input

The Analog Input Configuration Page has a tab for each of the four analog inputs. Click on the desired input tab to bring up the configuration dialog box.

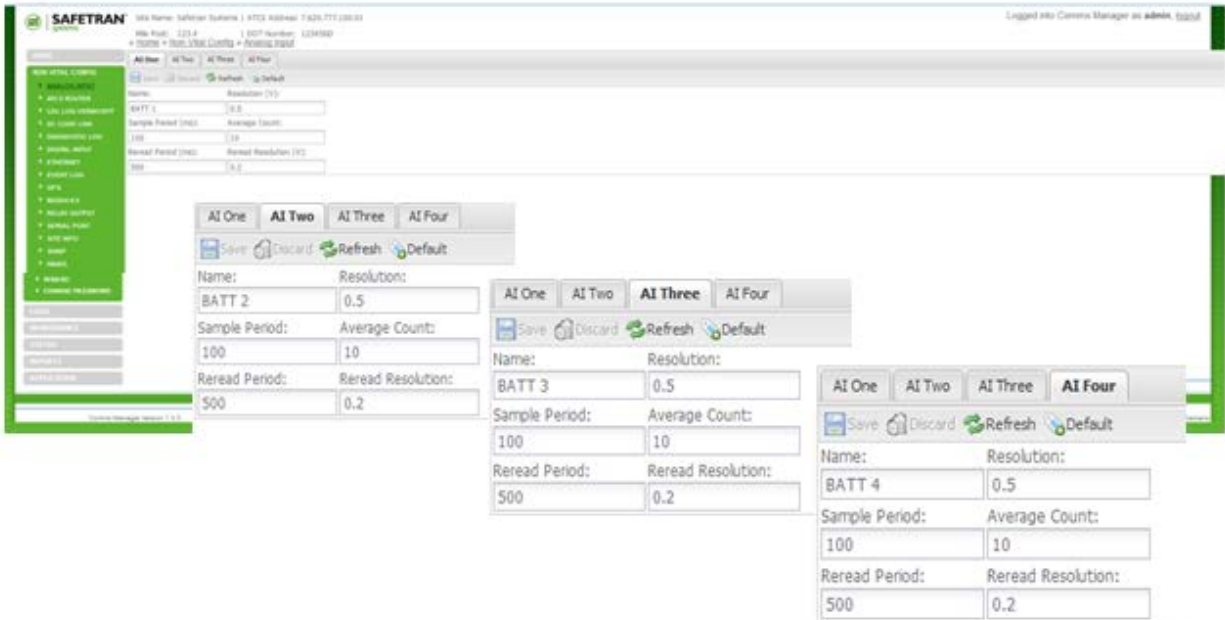

Figure 4-10 Analog Input Configuration Page

Click on the **Refresh** button to re-populate the dialog boxes with the current configuration parameters. Clicking on the **Default** button will insert all of the default values in each parameter.



Save the new entries by clicking on the **Save** button. The **Discard** button will remove all changes and restore all configuration parameters to the values prior to making the changes.



The figure and chart below details the Parameters, Range, and Default settings as well as a description for the four Analog Inputs.

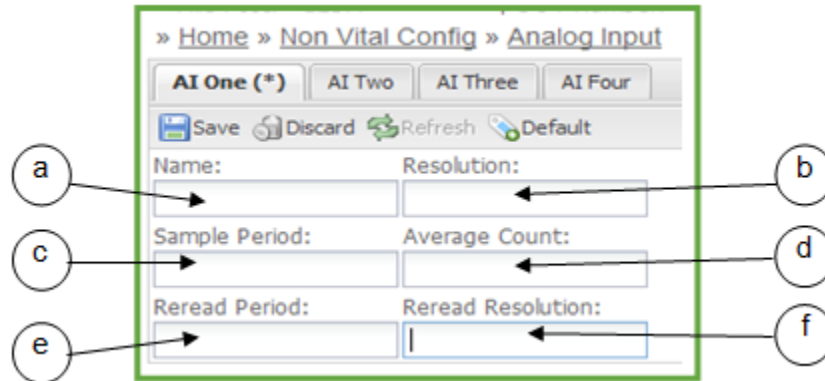

Figure 4-11 Analog Input Parameters

Table 4-1 Analog Input Parameters and Descriptions

	Parameter	Range	Default	Description
a	Name	0 to 10 characters	BATT X (where X is the input number)	Up to 10 characters long and used to describe the input in event reports.
b	Resolution	0.1V to 36.0V	0.5 V	Specifies the change in voltage required before an event will be logged into the event log. The voltage is calculated as the average of the number "Samples to Average".
c	Sample Period	100 – 60000 milliseconds	100 ms	Specifies the number of consecutive samples to average together to determine the voltage present on the input. A list of the last "Samples to Average" samples is kept as the voltage readings are taken. At each sample period, the list of voltage readings is averaged together to determine the voltage value.
d	Average Count	1 – 64 samples	10	Specifies the number of voltage samples to average together to calculate the input voltage.
e	Re-read Period	100 – 60000 milliseconds	500 ms	Specifies the time between voltage samples.
f	Re-read Resolution	0.0V (off) to 36.0V	0.2 V	The voltage difference required to log another event after the re-read comparison is performed.

4.3.4.2 ATCS Router

Click on **ATCS ROUTER**, from the list of configuration sub-menus to bring up the ATCS Router Configuration Page.

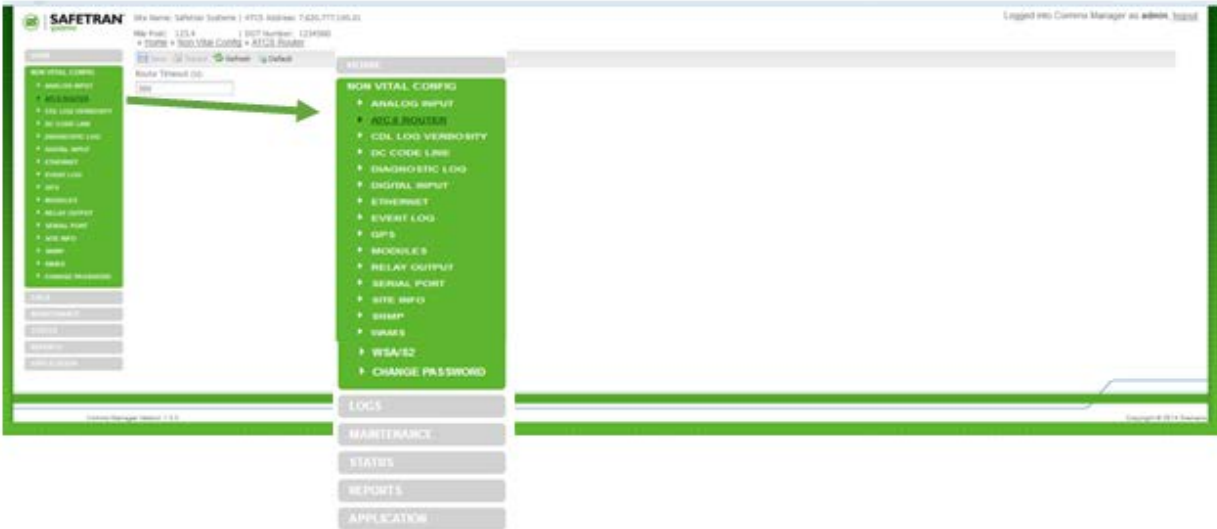

Figure 4-12 ATCS Router Sub-Menu

The Communications Manager will learn ATCS routes from received messages, or in some instances routes configured with external devices. The Route Timeout parameter establishes the amount of time that an ATCS address has not been heard from before Communications Manager removes the address from the route table. The route will be re-established when contact with the address returns. The timeout can be set for up to 48 hours. Communications Manager's routing table can be viewed from the Status Menu selection Route Table.

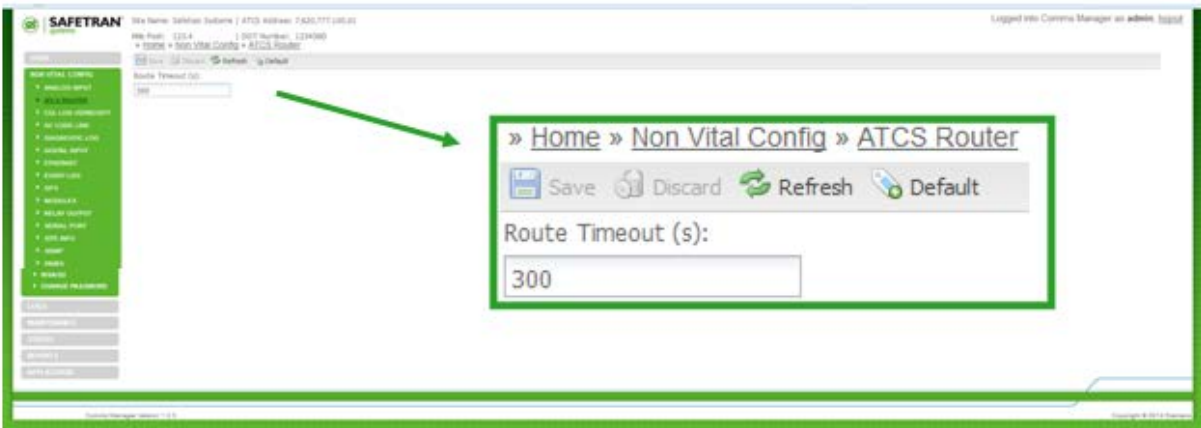

Figure 4-13 ATCS Router Configuration Page

Table 4-2 ATCS Router Configuration Parameters

Option	Range	Default	Description
Route Timeout	0 - 172800 seconds (up to 48 hours). A value of 0 means the routes never expire.	300 seconds	If messages are not heard from an ATCS address for this time period, the address is removed from the route table

4.3.4.3 CDL Log Verbosity Level

The CDL Log Level can be configured in one of five levels:

- **BASIC (level 1)** - Operation and access information.
- **ERROR (level 2)** – Critical problems that may need immediate attention.
- **WARNING (level 3)** – Possible issues that may or may not need correction.
- **INFO (level 4)** – Helpful information about present operation.
- **DEBUG (level 5)** – For Siemens personnel.

The verbosity level of logging may be chosen such that any entry that has the same level or lower will be added to the log. Higher leveled entries will not be added to the log. The default verbosity level is Basic. The system log stores at least 1,000 entries.

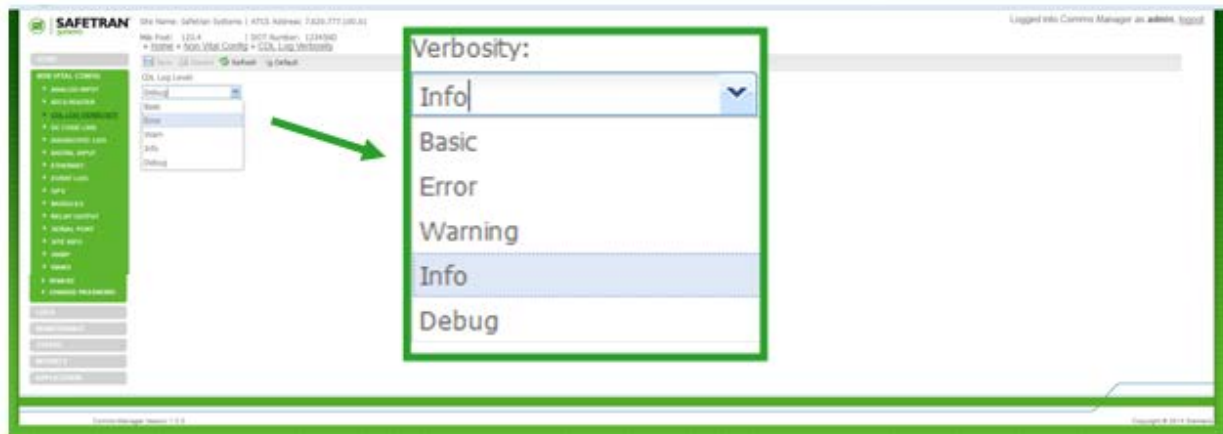

Figure 4-14 Configuration Menu – CDL Log Verbosity

4.3.4.4 DC Code Line

The Communications manager supports a single code unit running a DC Code Line protocol. The Communications Manager currently supports the K2 code line protocol and will support H code and J Code in future releases.

The Communications Manager can operate in two modes; Protocol Conversion and Non-vital Logic Controller.

- **Protocol Conversion Mode**

When the Communications Manager is acting as a protocol converter, it receives K2 indication data on the Code In input (analog input 4 is disabled) and converts the indication data into an ATCS indication message and delivers that message to the office system. The Communications Manager creates an ATCS address for the unit when converting the data. When the Communications Manager receives an ATCS control destined for the created address, the Communications Manager will convert it from ATCS format into K2 format and step out the control on the Communications Manager's Code Out output 1.

When the Communications Manager receives an ATCS recall, it will NOT send a K2 recheck frame but will instead briefly toggle the RLY1 output. RLY1 must be wired into the K2 code unit to trigger it to send an indication. The recheck method prevents the Communications Manager from delivering stale control data in a K2 recheck frame. The user may set the duration RLY1 is on to trigger the indication.

Because an ATCS office system expects an indication message from a location once per minute, the Communications Manager will resend the last received indication from the K2 code unit once per minute. That will prevent the office from going into code fail. However, the Communications Manager can periodically recheck the K2 code unit to ensure it is still operating. If the Communications Manager does not receive any indications (response from a recheck or otherwise) for the configurable Recheck Period plus 5 minutes, it will stop sending the periodic indications to the office. The office will time out the location and report code fail. If Periodic Rechecks are not enabled, the Communications Manager will always send the once per minute indication from its last received data.

In this mode of operation the Communications Manager and the K2 code unit are each independently addressable by the office system.

- **Non-Vital Logic Controller Mode**

When the Communications Manager is in this mode of operation, it does not directly send the K2 indication to the office system or deliver an ATCS control to the code unit. Instead, it copies the indication data received from the K2 code unit into the “I bits” of the ladder logic bit map. That allows the ladder logic program to operate on the data to create the indication sent to the office. The Communications Manager will also copy data from the “O bits” of the ladder logic bit map into the control stepped out to the K2 code unit. That allows the ladder logic program to operate on the ATCS control data before delivering it to the K2 code unit. This mode of operation allows the ladder logic program to perform local or remote control of the location using a ULCP, for example, and is similar to a CM/GEO combination.

In this mode, the Communications Manager will still perform a periodic recheck of the K2 code unit, if configured to do so. Executive bit E0005 will be set if the Communications Manager has received responses to the periodic rechecks and will be clear if the Communications Manager has not received a response from the K2 code unit. The Communications Manager will clear the E0005 bit if has not received an indication from the code unit for the configured Recheck Period plus 5 minutes. The ladder logic can choose to stop indications (using the Indicate Enabled executive bit) or set a bit in the indication messages sent to the office, if the code unit is offline.

- **DC Code Line Settings**

The DC Code Line screen has three modes, None, K2, and H. H is not functional at this time and will be available along with Mode J in a future release.

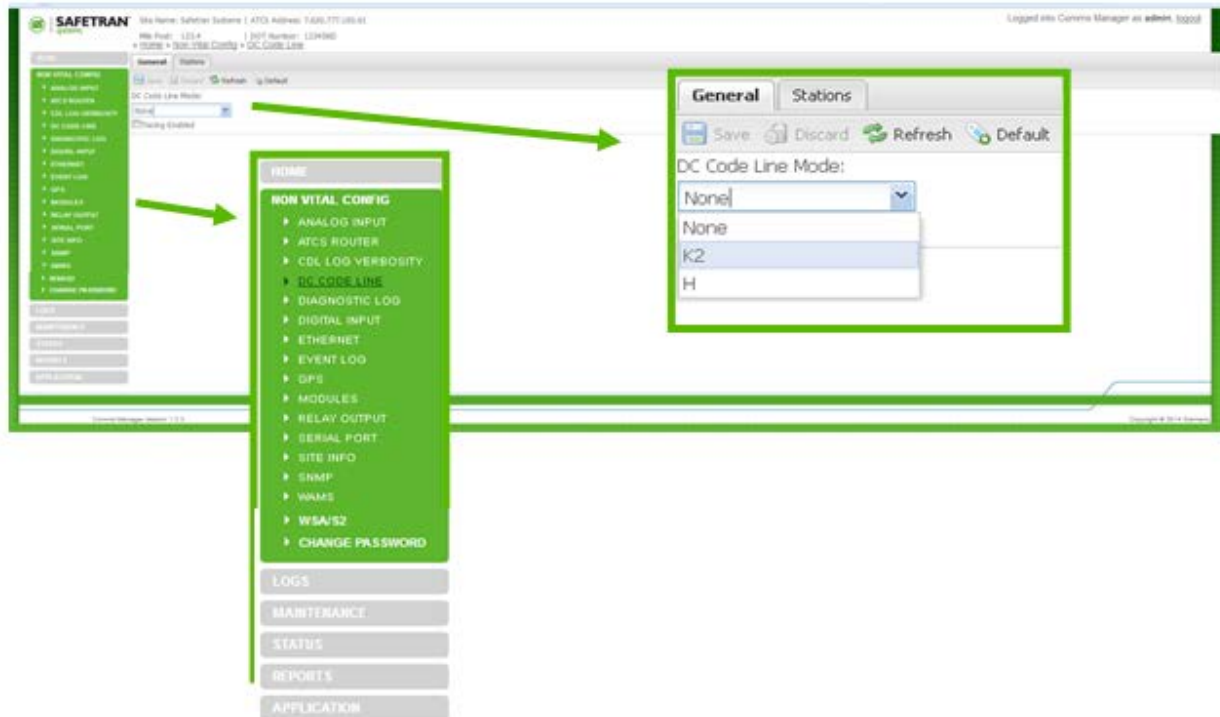

Figure 4-15 DC Code Line Modes

Selecting None on the DC Code Line Mode menu will disable DC Code Line.

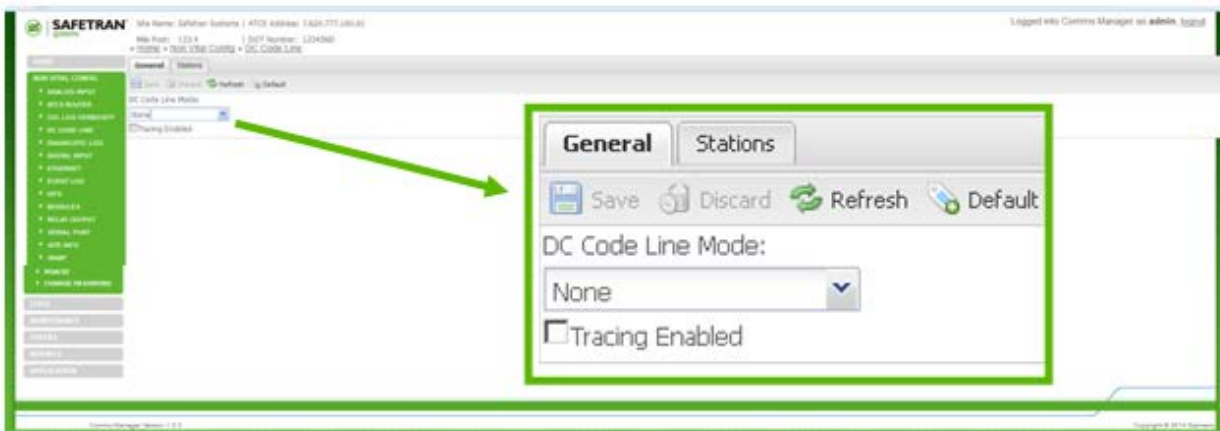

Figure 4-16 DC Code Line Disabled

The K2 DC Code Line Mode screen will display the user programmable parameters as shown in Figure 4-17.

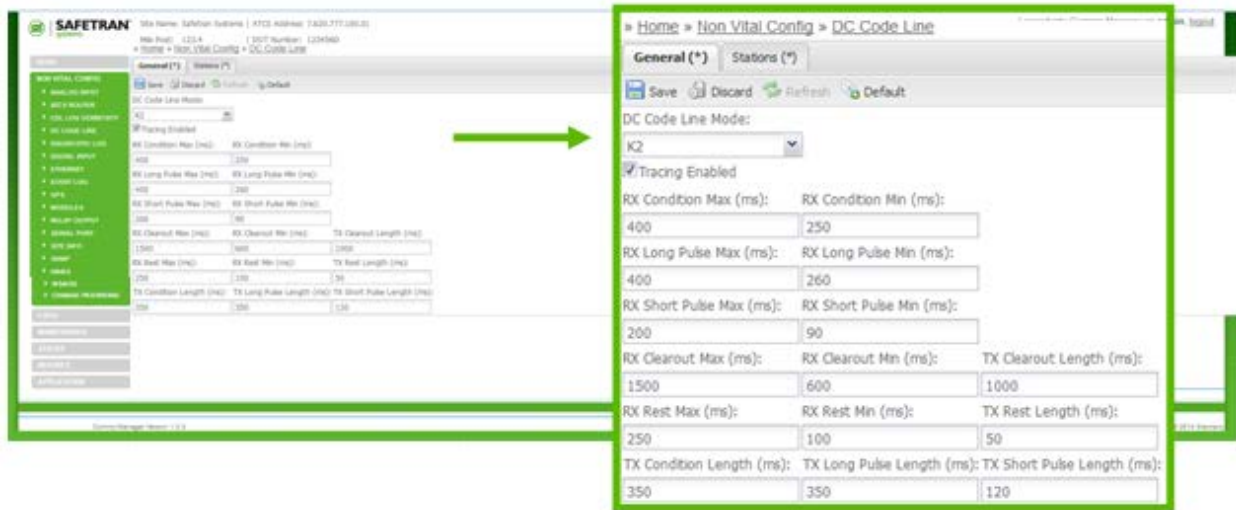

Figure 4-17 DC Code Line Mode K2 General Parameters

Click on the Stations tab to display the Station parameters as shown in Figure 4-18.

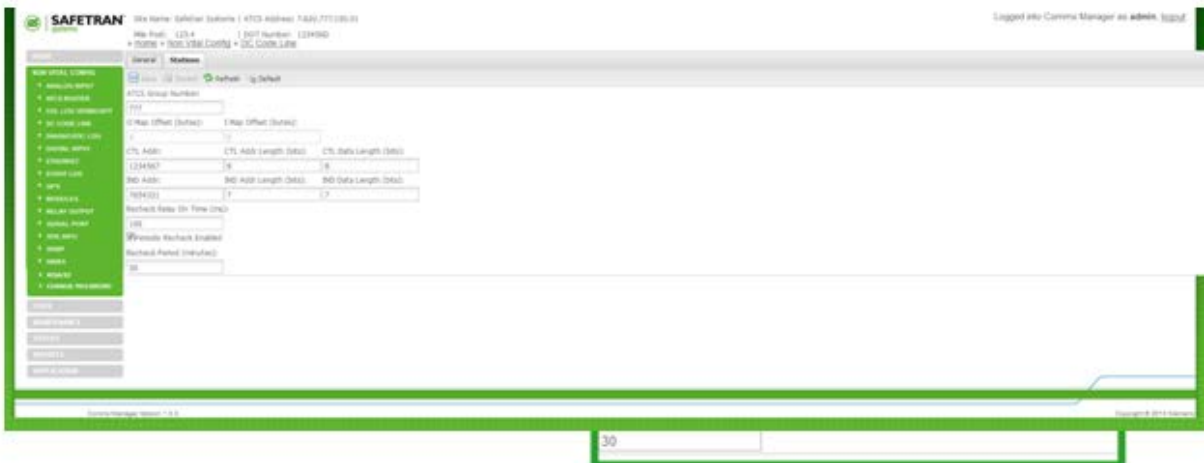

Figure 4-18 DC Code Line Mode K2 Stations Parameters

The following are the user configurable settings for the DC Code Line functions:

Table 4-3 DC Code Line Settings

Setting	Range	Description
DC Code Line Mode	NONE or K2 (H and J will be available in the future)	Sets the DC code line mode and protocol. If set to NONE, no DC code unit is supported and analog input 4 and relay output 2 operate as normal. If set to K2, the CM will attempt to communicate with a K2 code unit relay output 2 will be disabled and instead will operate as 2 DC code outputs. Analog input 4 will be disabled and will operate as the DC code input.
Tracing Enabled	Yes or No	If enabled, the CM will log the timing of each change of the DC code input into the diagnostic log. This can be used to find the proper range of times for the K2 settings.
K2 Specific Settings		
RX Condition Min/Max (ms)	10 – 5000 milliseconds	The range of time the CM will accept for the conditioning period of a K2 indication. If it is not within the expected range, the CM will discard the received data.
RX Long Pulse Min/Max (ms)	10 – 5000 milliseconds	The range of time the CM will accept for a Long Pulse.
RX Short Pulse Min/Max (ms)	10 – 5000 milliseconds	The range of time the CM will accept for a Short Pulse.
RX Clearout Min/Max (ms)	10 – 5000 milliseconds	The range of time the CM will accept for the clearout period.
RX Rest Min/Max (ms)	10 – 5000 milliseconds	The CM doesn't currently use these settings and will immediately be able to receive another indication after the completion of the first. These are reserved for potential future use.
TX Condition Length (ms)	10 – 5000 milliseconds	The length of time the CM will hold the conditioning period.
TX Long Pulse Length (ms)	10 – 5000 milliseconds	The length of time the CM will send a Long Pulse.
TX Short Pulse Length (ms)	10 – 5000 milliseconds	The length of time the CM will send a short pulse.
TX Clearout Length (ms)	10 – 5000 milliseconds	The length of time the CM will send the clearout period.
TX Rest Length (ms)	10 – 5000 milliseconds	The length of time the CM will rest before sending another control.
Station Settings		
ATCS Group Number	0 – 999	If set to 0, the CM will operation in "Non-vital logic controller mode". If set to a non-zero value, the CM will operate in "Protocol Conversion" mode and the created ATCS address for the code unit will use the CM's site ATCS address with the group number replaced by this value.

O Map Offset (bytes)	0 – 31	Only applicable if the ATCS group number is set to 0. This is the offset in bytes into the O map in the ladder logic bits. The CM will copy these bits into the control sent to the code unit. The number of bits is determined by the CTL Data Length setting.
I Map Offset (bytes)	0 – 31	Only applicable if the ATCS group number is set to 0. This is the offset in bytes into the I map in the ladder logic bits. The CM will copy the bits received from the code unit into the map at this offset. The number of bits copied is determined by the IND Data Length setting.
CTL Addr	0 – 2147483647	The control address for the code unit, in decimal.
CTL Addr Length (bits)	0 – 32	The length of the CTL Addr in bits.
CTL Data Length (bits)	0 – 32	The length of the control data stepped out to the code unit (and number of bits to copy from ladder logic bitmap, if enabled).
IND Addr	0 – 2147483647	The indication address for the code unit, in decimal.
IND Addr Length (bits)	0 – 32	The length of the IND Addr in bits.
IND Data Length (bits)	0 – 32	The length of the indication data expected to receive from the code unit (and number of bits to copy into ladder logic bitmap, if enabled).
Recheck Relay On Time (ms)	100 – 10000 milliseconds	The number of milliseconds the CM will turn RLY1 on to trigger the code unit to step out an indication.
Periodic Recheck Enabled	Yes or No	If enabled, the CM will periodically toggle RLY1 to trigger the code unit to step out an indication. The period is determined by the Recheck Period setting.
Recheck Period (minutes)	10 – 65535 minutes	If Periodic Recheck Enabled is yes, the CM will perform the recheck on this interval.

4.3.4.5 Diagnostic Log Configuration

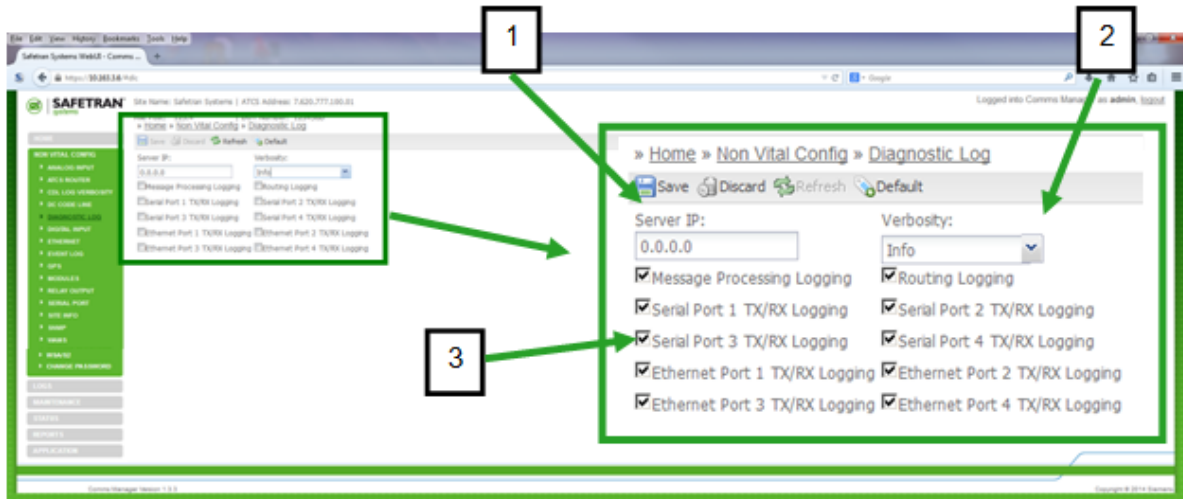

1 Server IP:

When one or more Communication Managers are operating on a network, each Communications Manager can be configured to forward all diagnostic events over the network to a remote "Consolidated Logger" and continue to log events locally. The Logger will maintain all of the events for every reporting Communications Manager.

Enter the IP Address of the remote Logger in the Server IP box. If "0", logging is handled locally only.

2 Verbosity:

BASIC (Level 1) - Operation and access information

ERROR (Level 2) – Critical problems that may need immediate attention

WARNING (Level 3) – Possible issues that may or may not need correction

INFO (Level 4) – Helpful information about present operation (**Default**)

DEBUG (Level 5) –If set to Debug, every event will be logged

The verbosity level of logging may be chosen such that any entry that has the same level or lower will be added to the log. Higher leveled entries will not be added to the log. The default verbosity level is Info. The system log stores at least 7,500 entries.

3 Logging Options:

Checking the box next to each item will enable logging for that function. Only functions selected will be included in the log.

Figure 4-19 Configuration Menu – Diagnostic Log

4.3.4.6 Digital Input Configuration

Click on the **Digital Input** sub-menu to bring up the Digital Input Configuration page.

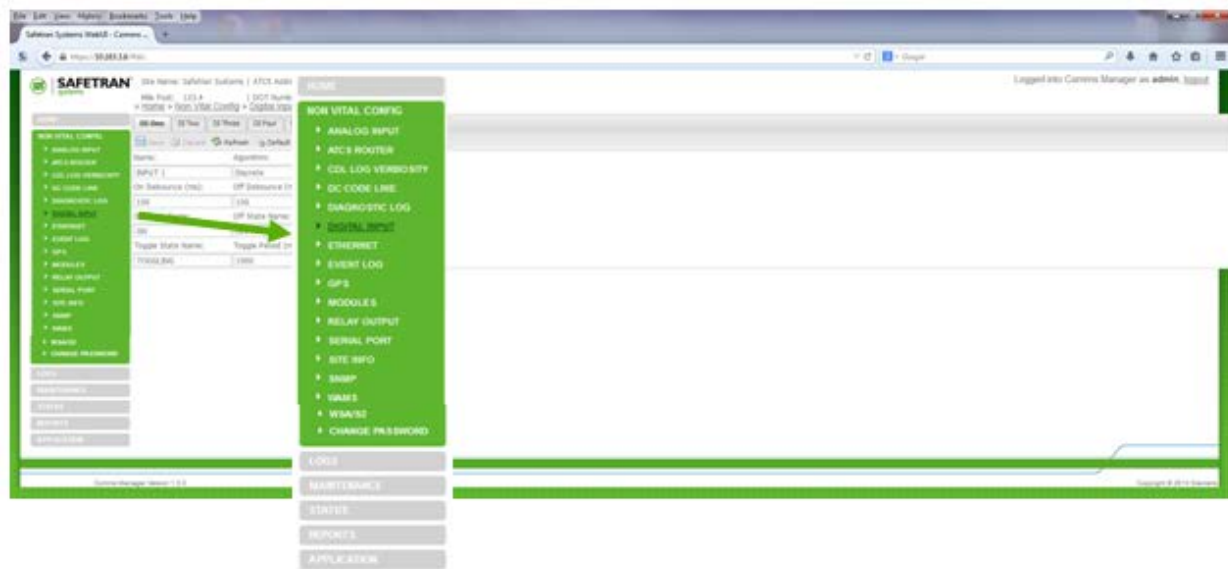

Figure 4-20 Configuration Menu – Digital Input

Each of the eight digital inputs can be configured with a **Discrete** or **GFT** algorithm as shown in the figure below. An input configured with the "**Discrete**" algorithm logs the state of the I/O connected to that input as either **OFF**, **ON**, or **TOGGLING**. An input configured with the "**GFT**" algorithm should be connected to an Siemens Ground Fault Tester. GFT inputs log the fault/no fault state of each of the GFT's connected batteries as well as other status information related to the GFT.

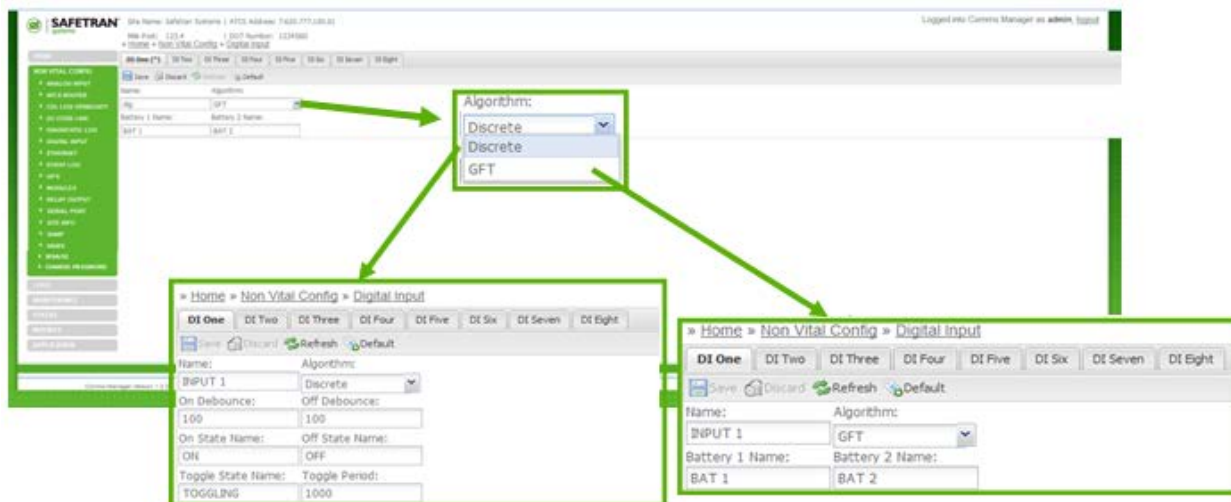

Figure 4-21 Digital Input Configuration Page

Click on the **Refresh** button to re-populate the dialog boxes with the current configuration parameters. Clicking on the **Default** button will insert all of the default values in each parameter.



Save the new entries by clicking on the **Save** button. The **Discard** button will remove all changes and restore all configuration parameters to the values prior to making the changes.



The figure and chart below details the parameters for each Digital I/O port and their default settings for a **Discrete** Algorithm.

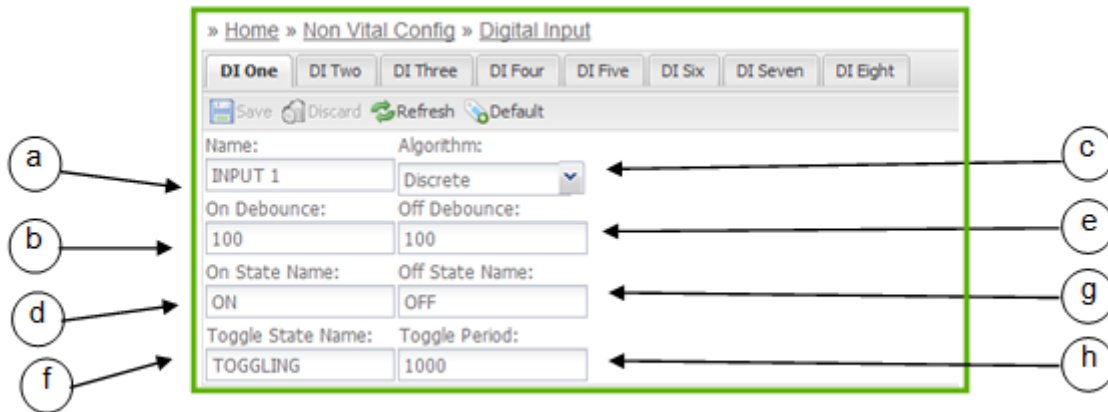

	Parameter	Range	Default
a	Name	0 to 10 characters	INPUT X (where X is the input number)
b	On De-bounce	0 to 60000 milliseconds	100
c	Algorithm	Discrete or GFT	Discrete
d	On State Name	0 to 10 characters	ON
e	Off De-bounce	0 to 60000 milliseconds	100
f	Toggle State Name	0 to 10 characters	TOGGLING
g	Off State Name	0 to 10 characters	OFF
h	Toggle Period	0 to 60000 milliseconds	1000 milliseconds

Figure 4-22 Digital I/O Parameters – Discrete Algorithm

The figure and chart below details the parameters for each Digital I/O port and their default settings for a **GFT** Algorithm.

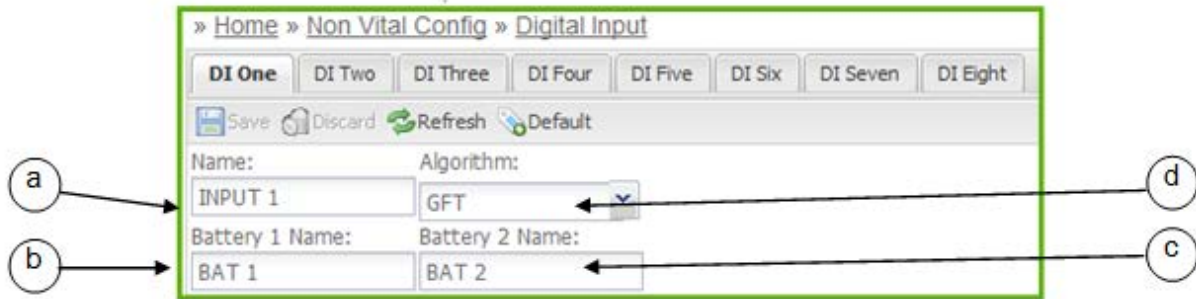

	Parameter	Range	Default
a	Name	0 to 10 characters	INPUT X (where X is the input number)
b	Battery 1 Name	0 to 10 characters	BAT 1
c	Battery 2 Name	0 to 10 characters	BAT 2
d	Algorithm	Discrete or GFT	Discrete

Figure 4-23 Digital I/O Parameters – GFT Algorithm

4.3.4.7 Ethernet Ports

Ethernet Ports include the Laptop Port located on the front panel's Local User Interface section and four Ethernet ports located on the bottom of the unit. Click on **Ethernet** sub-menu on the Non Vital Config menu.

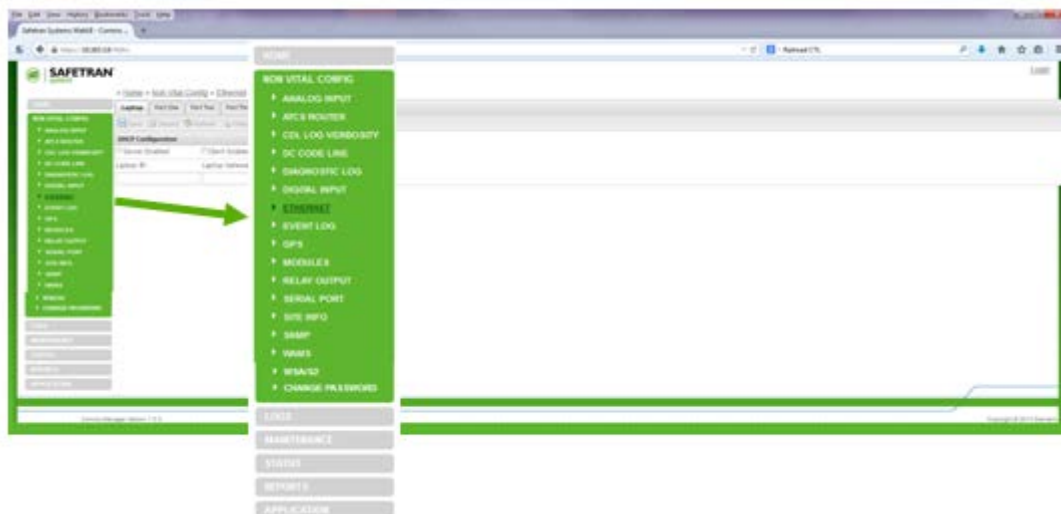
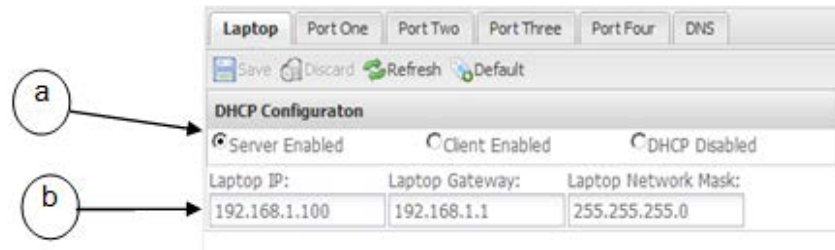

Figure 4-24 Ethernet Ports Configuration Menu

- **Laptop Ethernet Port**

The Laptop Ethernet Port has the following user configuration parameters.



	Parameter	Range	Default	Description
a	DHCP Configuration	Server Enabled Client Enabled DCHP Disabled	Server Enabled	Set DHCP as a Server, Client, or Disables DHCP
b	Laptop IP Laptop Gateway Laptop Network Mask	0.0.0.0 - 255.255.255.255	192.168.1.100 192.168.1.1 255.255.255.0	Sets address for IP, Gateway, and Network Mask

Figure 4-25 Ethernet Ports – Laptop Port

NOTE

NOTE

The internal DHCP server always assigns the IP address to the attached client. Therefore, it is not recommended to change the IP address, gateway, and network mask of the laptop Ethernet port from the defaults if the DHCP server is enabled.

- **Ethernet Port 1 - 4**

The four Ethernet Ports can be configured as **None** (no path type or protocol) or as an **ATCS/IP Protocol** and either an **Office Primary**, **Office Backup 1**, **Office Backup 2**, or an **Office Backup 3**.

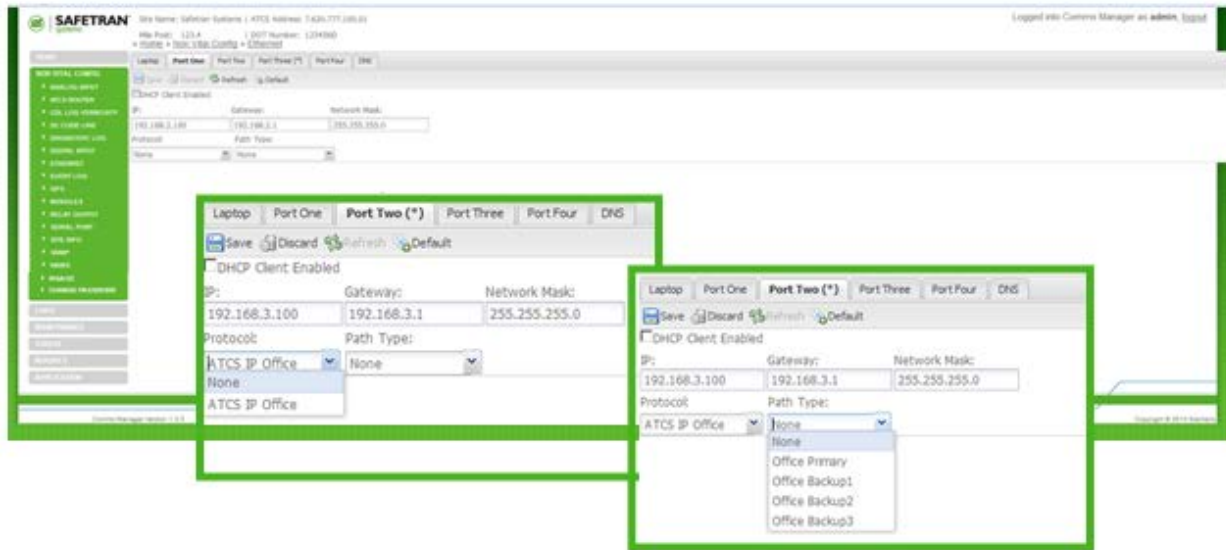

Figure 4-26 Ethernet Port 1 – 4 Path and Protocol Selection

NOTE

NOTE

If a protocol parameter is selected, then a path type parameter must also be selected and vice-versa. Selecting the **ATCS/IP Protocol** will require also selecting one of the Office path types or the unit will revert to no path type and no protocol (Protocol: **None** and Path Type: **None**) when saved. If an Office path type is selected and Protocol is set to **None**, the unit will default the Protocol to **ATCS/IP**.

- **Ethernet Port 1 – 4 ATCS/IP Office Configuration**

The following diagram and chart displays and describes the user configuration options for the ATCS/IP Protocol.

The screenshot displays the SAFETRAN Web User Interface for configuring Ethernet Port One. The configuration panel is highlighted with a green border and contains the following settings:

Field	Value	Field	Value	Field	Value
IP:	192.168.2.100	Gateway:	192.168.2.1	Network Mask:	255.255.255.0
Protocol:	ATCS IP Office	Path Type:	Office Primary		
Path Recovery Time (s):	300	Path Test Period (s):	60		
Path Fail Count:	6	RSSI Value:	61		
<input type="checkbox"/> Operational Traffic Only					
OCG Circuit ID:	620.1.1	Routing Region One:	192.168.2.2	Routing Region Two:	192.168.2.3
OCG Port:	5361	Path Value:	72	Route Search Time (s):	15
Route Search Thres:	4	Route Refresh Time (min):	5		

Figure 4-27 Ethernet Port 1 – 4 ATCS/IP Configuration

Table 4-4 Ethernet Port 1 – 4 ATCS/IP Configuration Parameters

Option	Range	Default	Description
Path Recovery Time	0 - 3600 seconds	300 seconds	The amount of time a path must successfully deliver messages with no losses before the path can be considered "Operational" again.
Path Test Period	0 - 7 Days	60 seconds	The time between attempts to send a test packet on a path in the "Failed", "In Recovery", or "Operational State", If the "Path Test Period" is set to zero the path will not be tested.
Path Fail Count		6	The minimum number of test packets that do not receive a response, causing a path to change from "In Recovery" to "Failed" state.
RSSI Value		61 - Office Primary 51 - Office Backup 1 41 - Office Backup 2 31 - Office Backup 3	Defines the RSSI value the office protocol will attach to the end of all ATCS RF_INFO packets transmitted on an office path. If the user sets the value to 0, the Communications Manager will not attach an RSSI value.
Operational Traffic Only	Yes = Checked box No = Empty box	No	If checked, the Communications Manager sends only controls and indication on the path. All other messages are discarded.
Circuit ID	0.0.0 (disabled)	0.0.0 (disabled)	Used by OCG to uniquely identify this path
Routing Region One	0.0.0.0 - 255.255.255.255 or symbolic name (e.g. google.com)	0.0.0.0 (disabled)	The Destination IP Address to send route requests to.
Routing Region Two	0.0.0.0 - 255.255.255.255 or symbolic name (e.g. google.com)	0.0.0.0 (disabled)	The Destination IP Address to send route requests to should the first routing region not solicit a response.
OCG Port	0 - 65535	5361	The UDP port number to use for route requests
Path Value	0 - 255	72	A byte included in the layer 2 message header that indicates the type of path. This value is used by the OCG to manage connections.
Route Search Time	0 - 65535 seconds	15 seconds	If no office route update message has been received the amount of time to keep requesting a route update message until one is received. This will only occur for the number of tries configured before it gives up and discards the message.
Route Search Tries	0 - 255	4	The maximum number of tries for sending a route request message without receiving a route update message before discarding the message. A value of 0 will cause Communications Manager to not retry route requests.
Route Refresh Time	0 - 65535 minutes	5 minutes	The amount of time between re-requesting the route update message in order to refresh the existing route table. A value of 0 means the route is not refreshed.

- **DNS Configuration**

The Ethernet ports support use of up to three DNS Servers. The figure below displays the DNS configuration screen.

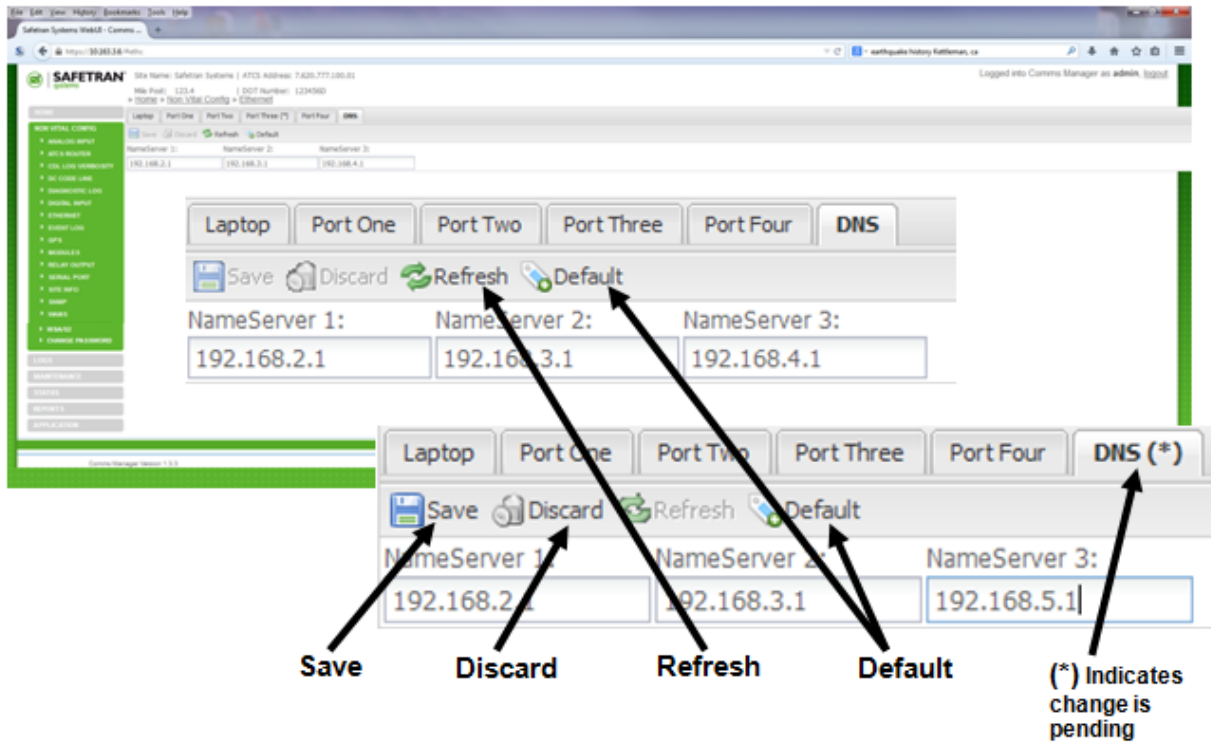

- Refresh** - Refreshes screen
- Save** - Saves changes entered in dialog boxes
- Discard** - Discards changes made in dialog boxes
- Default** - Restores default settings

Figure 4-28 DNS Server Configuration

Table 4-5 DNS Configuration Parameters

Parameter	Range	Default	Description
Nameserver 1	0.0.0.0 - 255.255.255.255	192.168.2.1	IP address of DNS server
Nameserver 2	0.0.0.0 - 255.255.255.255	192.168.3.1	IP address of DNS server
Nameserver 3	0.0.0.0 - 255.255.255.255	192.168.4.1	IP address of DNS server

4.3.4.8 Event Log Configuration

To configure the Event Log parameters click on the **Event Log** sub-menu on the Non Vital Config menu.

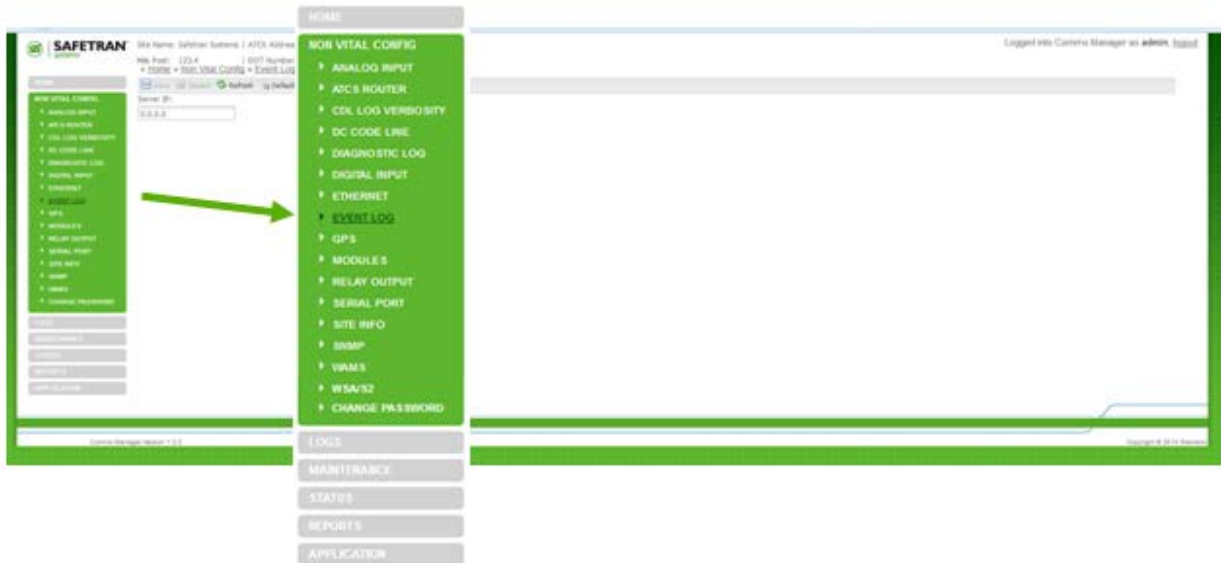

Figure 4-29 Configuration Menu – Event Log

The Event Log configuration has one parameter, Server IP.

Server IP: When one or more Communication Managers are operating on a network, each Communications Manager can be configured to forward all events over the network to a “Consolidated Logger” while continuing to log locally. The Logger will maintain all of the events for every reporting Communications Manager. The Consolidated Logger can be another Communications Manager.

Enter the IP Address of the Consolidated Logger in the **Server IP** box.

Server IP: Valid IP Address (Default is 0.0.0.0) If 0 logging is performed locally only.

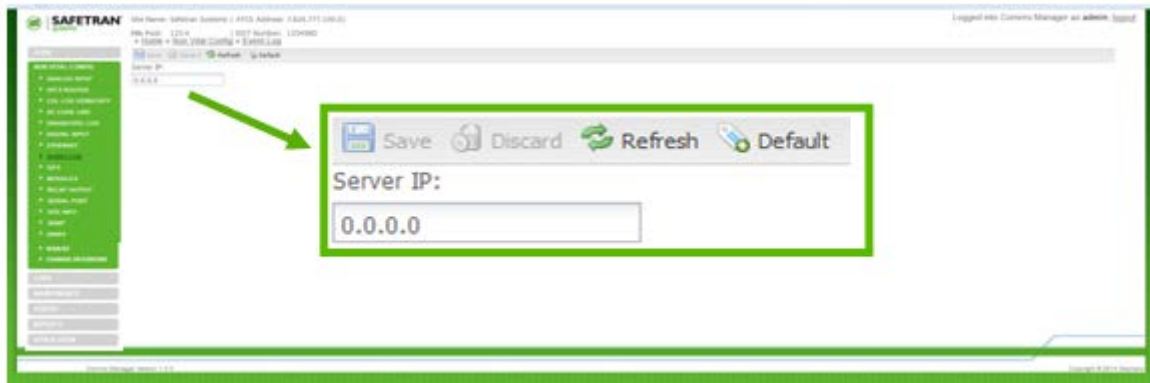

Figure 4-30 Event Log Configuration Page

4.3.4.9 GPS

Click on the **GPS** sub-menu to bring up the GPS configuration window.

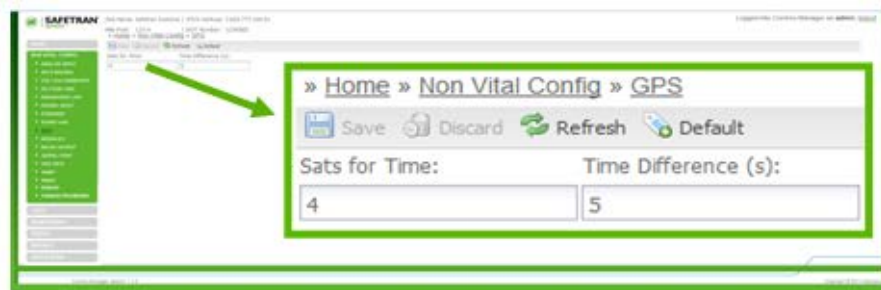

Figure 4-31 Configuration Menu – GPS

NOTE	NOTE
	The GPS feature is no longer available in Communications Manager Model 53475 Revision C3 or later.

- **DNS Configuration**

The GPS Configuration screen and descriptions are listed below.



Option	Range	Default	Description
Sats For Time	1 - 4	4	The number of satellites that must be in view before the Communications Manager will set its date/time from the GPS receiver's date/time information.
Time Difference	1 - 300 seconds	5 seconds	The number of seconds the GPS receiver's date/time and the system's present date/time must differ before the Communications Manager will set the date/time from the GPS.

Figure 4-32 GPS Configuration

4.3.4.10 Modules

To configure the Module parameters click on the **Modules** sub-menu on the Non Vital Config menu.



Figure 4-33 Configuration Menu - Modules

- **Module Configuration**

The Modules Configuration window shows installed Echelon® modules. Expanding the module drop down menu will display the parameters for each installed Echelon® module.

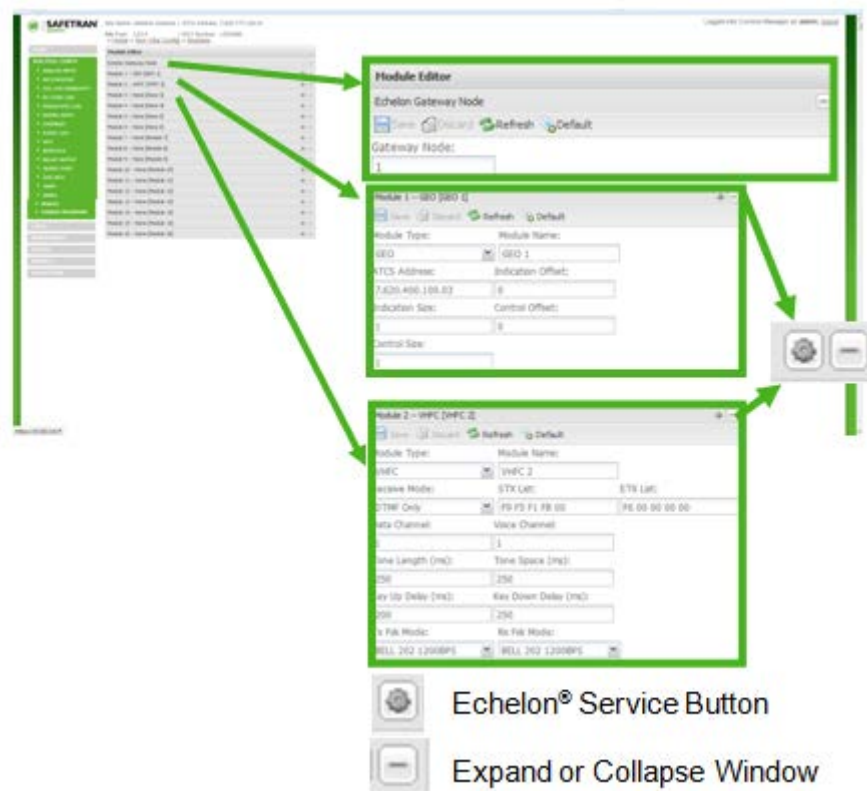

Figure 4-34 Module Configuration

- **Module Editor**

The following figures show the various module configurations supported by the Communication Manager.

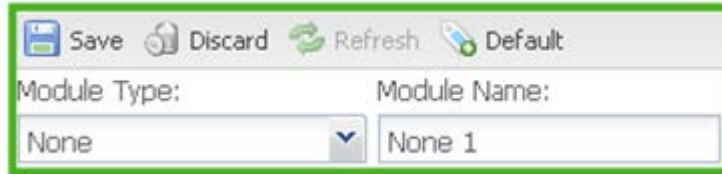

Figure 4-35 No Module Installed

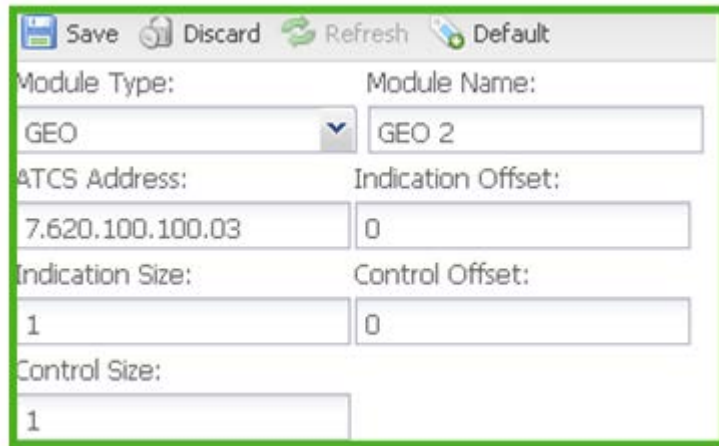

Figure 4-36 GEO

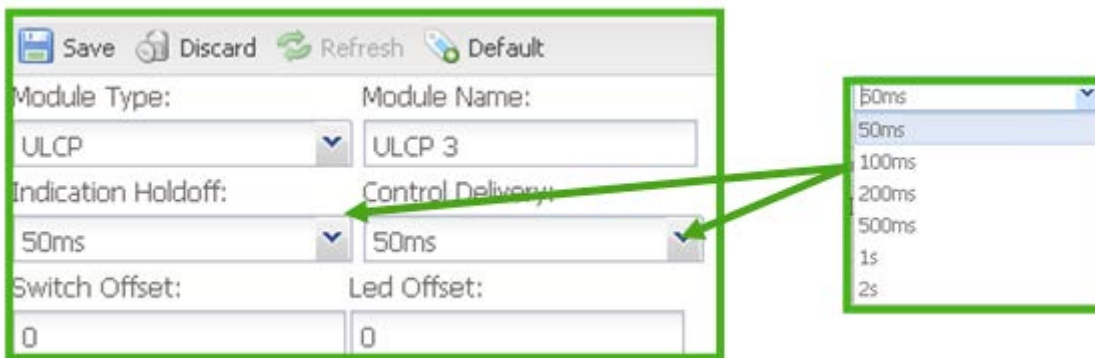

Figure 4-37 Universal Local Control Panel (ULCP)

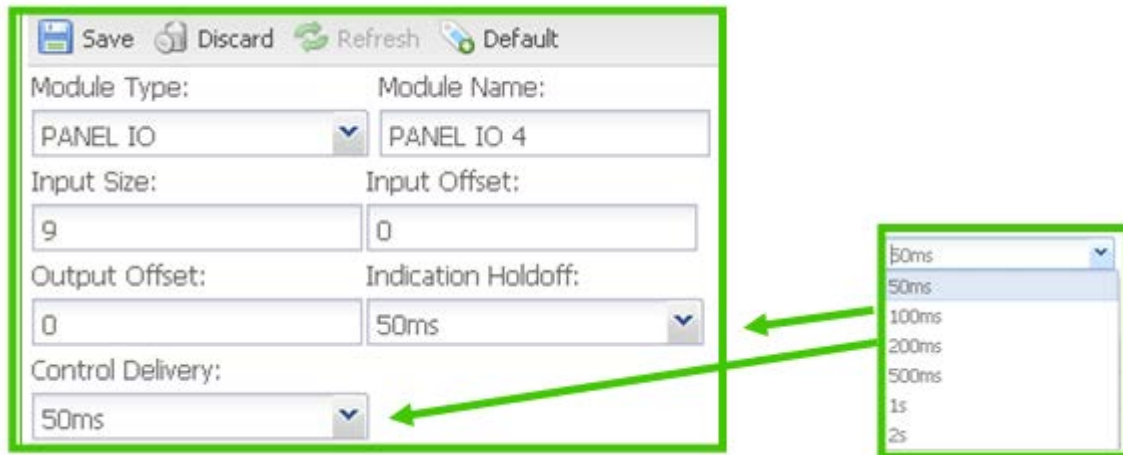

Figure 4-38 Panel I/O



Figure 4-39 VHF Communicator (VHFC)

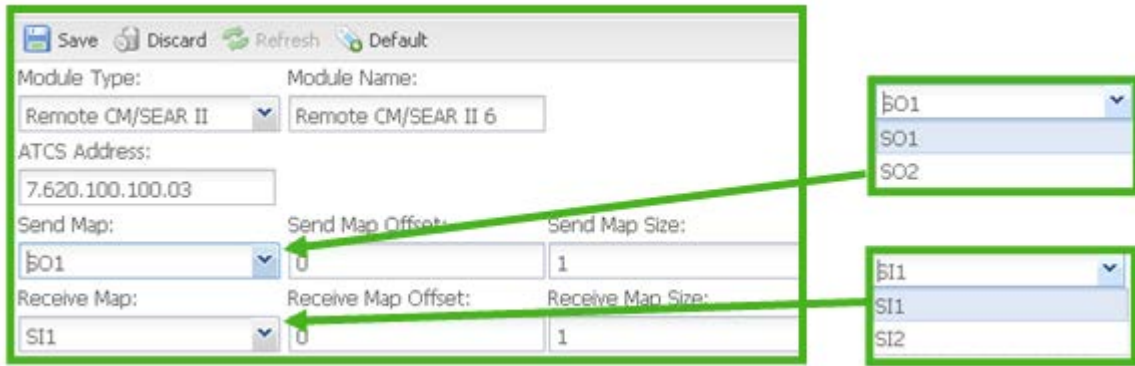

Figure 4-40 Remote CM/SEAR II

The following are the user configurable settings specific to the Remote CM/SEAR II:

Table 4-6 Remote CM/SEAR II Configurable Parameters

Setting	Range	Description
ATCS Address	Type 7 ATCS Address	The ATCS address of the remote unit.
Send Map	SO1 (X bits) or SO2 (Y bits)	The CM will copy the bits from this area of the bitmap into the messages it sends to the remote unit.
Send Map Offset (bytes)	0 – 31	The offset into the selected Send Map for the bits to send to the remote unit, in bytes, and starting at 0.
Send Map Size (bytes)	0 – 32	The number of bytes of ladder logic bits to send in the message to the remote unit.
Receive Map	SI1 (A bits) or SI2 (B bits)	The area of the ladder logic bit map the CM will copy received bits from the remote unit into.
Receive Map Offset (bytes)	0 – 31	The offset into the selected Receive Map for the bits copied from messages received from the remote unit.
Receive Map Size (bytes)	0 – 32	The number of bytes of ladder logic bits copied from the message from the remote unit.

4.3.4.11 Relay Output

To configure the Relay Output click on the **Relay Output** sub-menu on the Non Vital Config Menu.

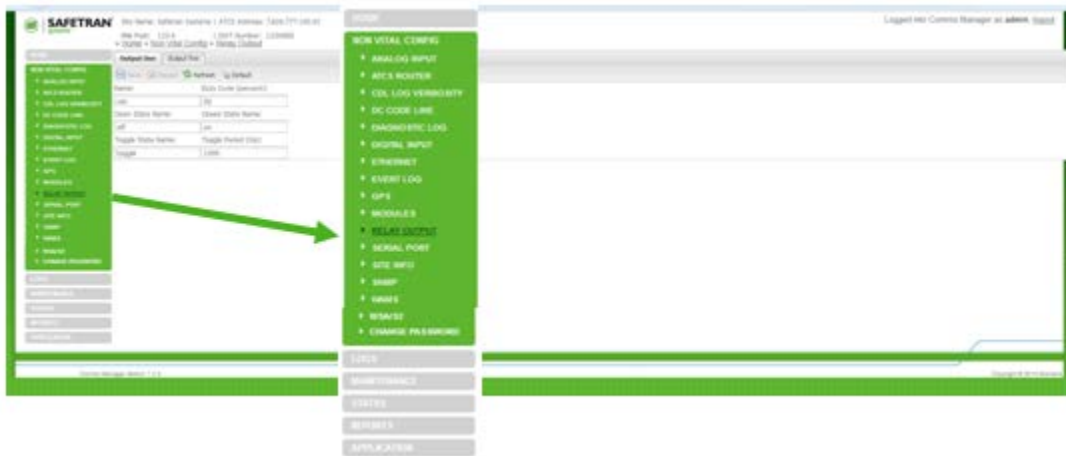

Figure 4-41 Configuration Menu – Relay Output

The Relay Output page has tabs for the two relay output configurations.

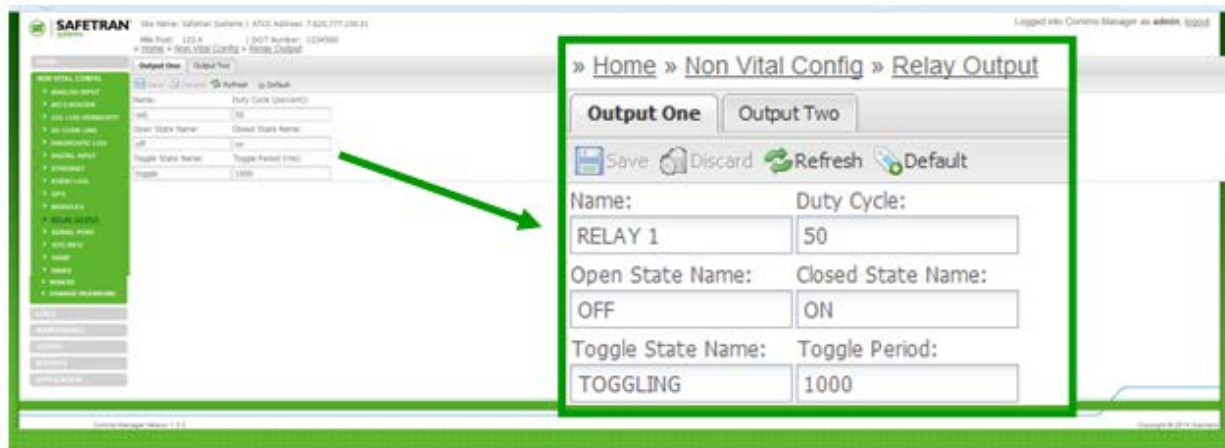

Figure 4-42 Relay Output Configuration Page

Click on the **Refresh** button to populate the relay output boxes with the current configuration parameters. Clicking on the **Default** button will insert all of the default values in each parameter.



Save the new entries by clicking on the **Save** button. The **Discard** button will remove all changes and restore all configuration parameters to the values prior to making the changes.



The figure and chart below details the parameters for each Relay I/O port and their default settings.

The screenshot shows a web interface for configuring Relay I/O parameters. It features two tabs: "Output One" (selected) and "Output Two". Below the tabs are four action buttons: "Save", "Discard", "Refresh", and "Default". The main configuration area contains six input fields arranged in three rows and two columns:

- Row 1: "Name:" (input: RELAY 1) and "Duty Cycle:" (input: 50)
- Row 2: "Open State Name:" (input: OFF) and "Closed State Name:" (input: ON)
- Row 3: "Toggle State Name:" (input: TOGGLING) and "Toggle Period:" (input: 1000)

Callouts a-f are placed around the interface:

- a: Points to the Name input field.
- b: Points to the Duty Cycle input field.
- c: Points to the Open State Name input field.
- d: Points to the Closed State Name input field.
- e: Points to the Toggle State Name input field.
- f: Points to the Toggle Period input field.

	Parameter	Range	Default
a	Name	0 to 10 characters	RELAY X (where X is the input number)
b	Duty Cycle	0 to 100 percent	50
c	Open State Name	0 to 10 characters	OPEN
d	Closed State Name	0 to 10 characters	CLOSED
e	Toggling State Name	0 to 10 characters	TOGGLING
f	Toggle Period	0 to 60000 milliseconds	1000

Figure 4-43 Relay I/O Parameters

4.3.4.12 Serial Ports

The Serial Ports are configured by clicking on the **Serial Port** sub-menu on the Non Vital Config Menu.



Figure 4-44 Serial Port Menu

- **Laptop Port**

The first tab is the **Laptop Port**. The following screen and chart detail the user configurable parameters.

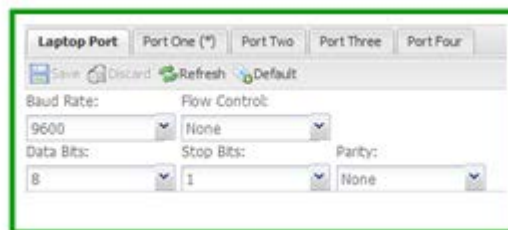

Parameter	Range	Default
Baud Rate	1200, 9600, 57600, or 115200	9600
Flow Control	None or Hardware	None
Data Bits	7 or 8	8
Parity	None, even, or odd	None
Stop Bits	1 or 2	1

Figure 4-45 Serial Laptop Port Parameters

- Serial Ports 1-2 (Full-Feature) – Field Path Type

The following are configuration options for full-featured serial ports 1-2 when the **Path Type** configuration parameter is selected as "**Field**". With Path Type set to "**Field**", this allows for nine protocol configuration parameter selections.

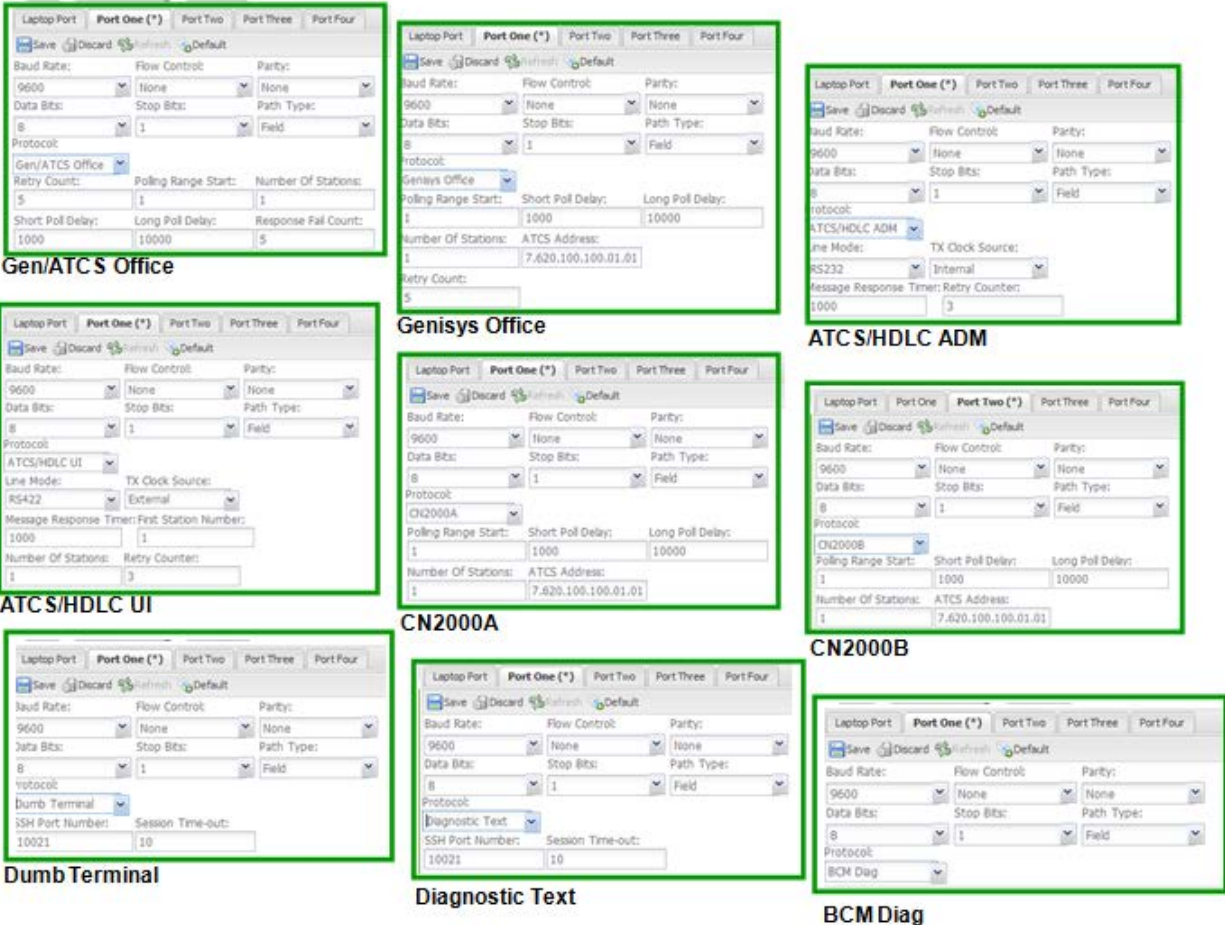

Figure 4-46 Serial Port 1-2 Field Path and Protocols

- **Serial Ports 1-2 (Full-Feature) – Office Primary/Office Backup 1,2, or 3 Path Type**

The following are configuration options for full-featured serial ports 1-2 when the **Path Type** configuration parameter is selected as "**Office Primary/Office Backup 1, 2, or 3**". With **Path Type** set to "**Office Primary/Office Backup 1, 2, or 3**", this allows for the following protocol configuration parameter selections.

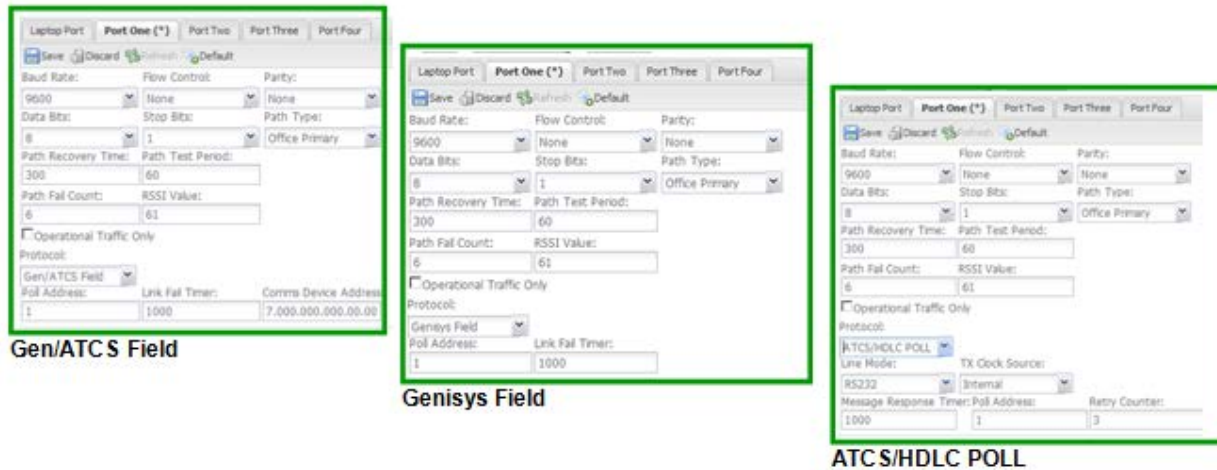

Figure 4-47 Serial Port 1-2 Office Primary and Backup 1, 2, & 3 Paths and Protocols

- **Serial Ports 3-4 (Partial-Feature) – Field Path Type**

The following are configuration options for partial-featured serial ports 3-4 when the **Path Type** configuration parameter is selected as "**Field**". With **Path Type** set to "**Field**", this allows for seven protocol configuration parameter selections.

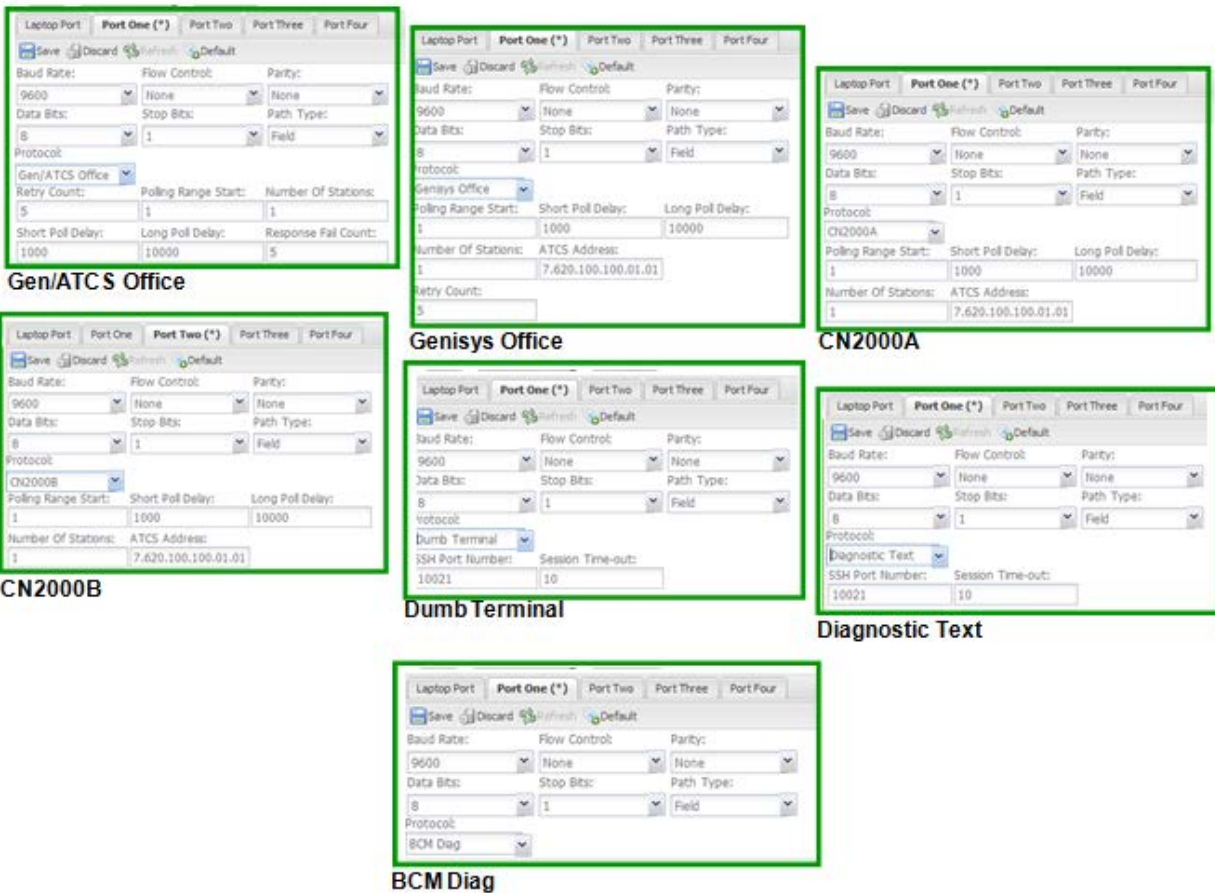

Figure 4-48 Serial Port 3-4 Field Path and Protocols

- **Serial Ports 3-4 (Partial-Feature) – Office Primary/Office Backup 1,2, or 3 Path Type**

The following are configuration options for partial-featured serial ports 3-4 when the **Path Type** configuration parameter is selected as "**Office Primary/Office Backup 1, 2, or 3**". With **Path Type** set to "**Office Primary/Office Backup 1, 2, or 3**", this allows for two protocol configuration parameter selections.

Gen/ATCS Field

Genisys Field

Figure 4-49 Serial Port 3-4 Office Primary and Backup 1, 2, & 3 Protocols

- **Site Info**

Click on the **Site Info** selection in the Non Vital Config menu to bring up the Site Info configuration page.



Figure 4-50 Site Info Configuration Menu

The Site Info configuration window is shown in the figure below. The following table lists and describes all of the available user options.

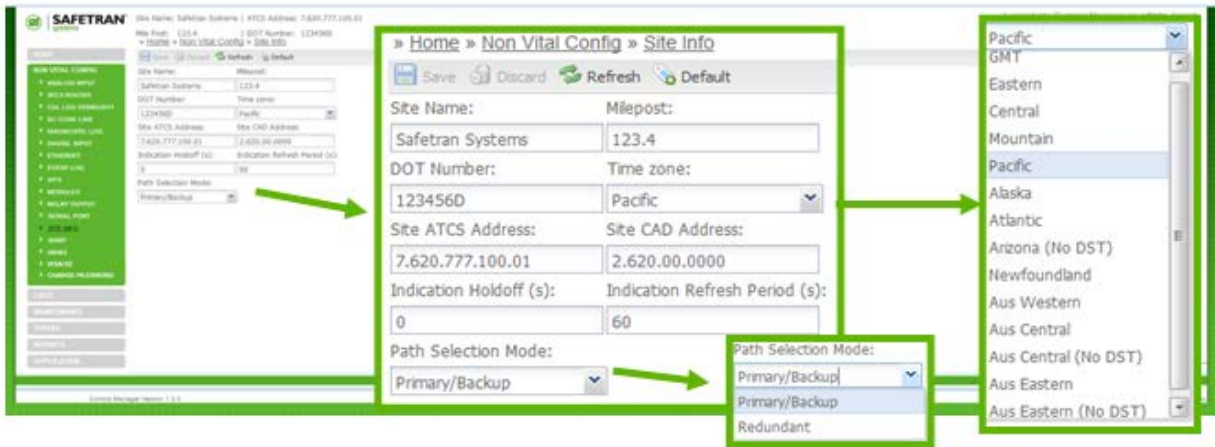

Figure 4-51 Site Info Configuration

Table 4-7 Site Info Configuration Options

Parameter	Range	Default	Description
Site Name	1 - 20 Characters	Safetran Systems	Communications Manager site name
Milepost	0 - 20 Characters	000.0	
DOT Number:	1 - 7 Characters	000000A	
Time zone:	GMT, EASTERN, CENTRAL, MOUNTAIN, PACIFIC, ALASKA, ATLANTIC, ARIZONA (NO DST), NEWFOUNDLAND, AUS WESTERN, AUS CENTRAL, AUS CNTRL (NO DST), AUS EASTERN, AUS EASTERN (NO DST)	EASTERN	
Site ATCS Address	7.000.000.000.00 - 7.999.999.999.99	7,620.100.100.01	Communications Manager ATCS address
CAD Address	2.000.00.0000 - 2.999.99.9999	2.620.00.0000	Office Dispatch ATCS address
Path Selection Mode	Primary/Backup or Redundant	Primary/Backup	Determines the method Communications Manager will use to send messages
Indication Refresh Period	0 (no refresh) - 600 seconds	60 seconds	Time interval for sending locally-generated indications
Indication Holdoff	0 (no holdoff) - 10 seconds	0 seconds	

4.3.4.13 SNMP Configuration

Select the **SNMP** sub-menu on the Non Vital Config menu to bring up the SNMP configuration window.



Figure 4-52 SNMP Configuration Menu

The SNMP configuration window is shown in the figure below. The following table lists and describes the user options. The SNMP trap can be disabled by entering **0.0.0.0** as the IP Address.

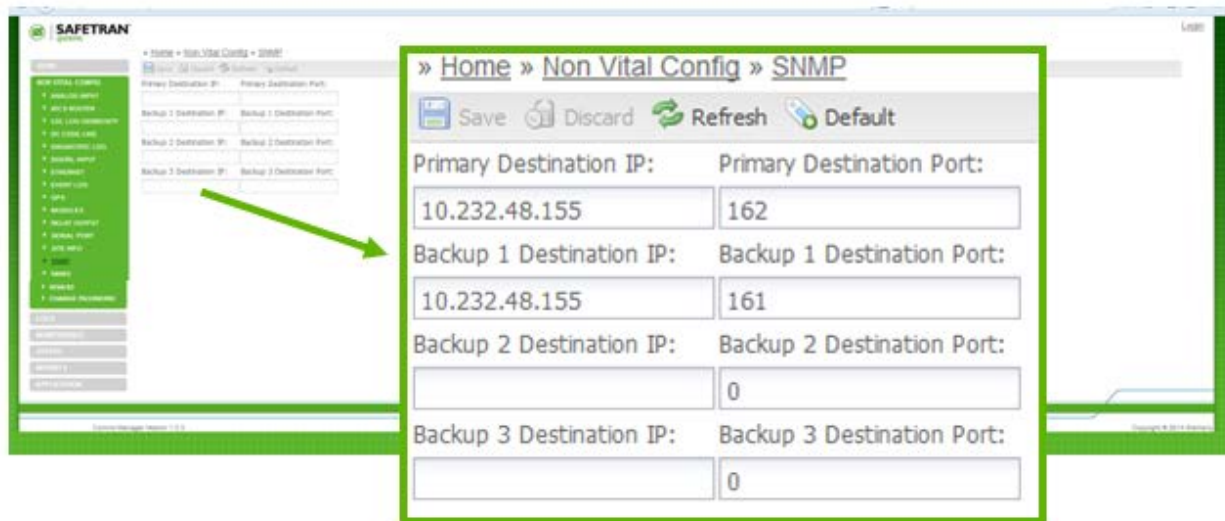

Figure 4-53 SNMP Configuration Options

Table 4-8 SNMP Configuration Parameters

Option	Range	Default	Description
Primary Destination IP	0.0.0.0 - 255.255.255.255 or symbolic name	0.0.0.0 (disabled)	The destination IP address to send SNMP traps when the currently active path is the primary path.
Primary Destination Port	0 - 65535	162	The destination IP Port Number to send SNMP Traps when the currently active path is the primary path.
Backup 1 Destination IP	0.0.0.0 - 255.255.255.255 or symbolic name	0.0.0.0 (disabled)	The destination IP address to send SNMP traps when the currently active path is the backup 1 path.
Backup 1 Destination Port	0 - 65535	162	The destination IP Port Number to send SNMP Traps when the currently active path is the backup 1 path.
Backup 2 Destination IP	0.0.0.0 - 255.255.255.255 or symbolic name	0.0.0.0 (disabled)	The destination IP address to send SNMP traps when the currently active path is the backup 2 path.
Backup 2 Destination Port	0 - 65535	162	The destination IP Port Number to send SNMP Traps when the currently active path is the backup 2 path.
Backup 3 Destination IP	0.0.0.0 - 255.255.255.255 or symbolic name	0.0.0.0 (disabled)	The destination IP address to send SNMP traps when the currently active path is the backup 3 path.
Backup 3 Destination Port	0 - 65535	162	The destination IP Port Number to send SNMP Traps when the currently active path is the backup 3 path.

NOTE**NOTE**

SNMP Traps can be disabled by setting the Destination IP addresses to the default value (0.0.0.0).

4.3.4.14 WAMS Configuration

Click on the **WAMS** sub-menu on the Non Vital Menu to bring up the WAMS Configuration window.

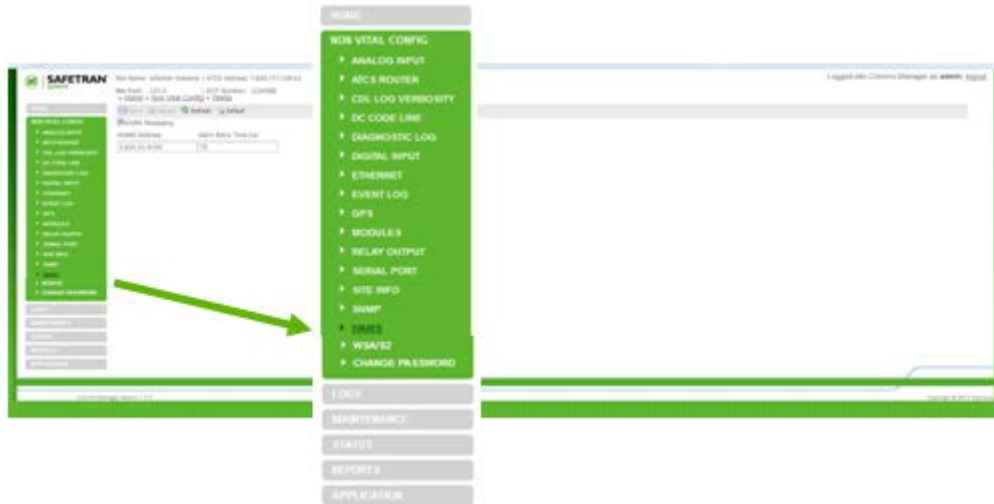

Figure 4-54 WAMS Configuration Menu

The WAMS Configuration window is shown in the figure below. The table describes the user configurable parameters.

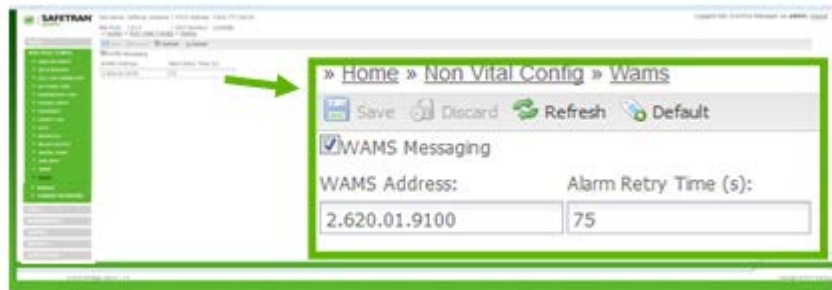

Figure 4-55 WAMS Configuration Window

Table 4-9 WAMS Configuration Parameters

Parameter	Range	Default	Description
WAMS Address	2.RRR.NN.DDDD	2.620.01.9100	When sending unsolicited messages to WAMS, the Communications Manager will send them to this destination ATCS address.
Alarm Retry Time	0 - 65535 seconds	75 seconds	When Communications Manager sends an alarm to WAMS it will wait the retry time for WAMS to acknowledge. If WAMS does not acknowledge within the retry time Communications Manager will send the alarm again.

4.3.4.15 WSA/S2 Configuration

Click on the WSA/S2 sub-menu on the Non Vital Menu to bring up the Westrace Freight configuration window.



Figure 4-56 WSA/S2 (Westrace Freight) Configuration Menu

The WSA/S2 configuration window is shown in Figure 4-57. Table 4-10 details the WSA/S2 parameters and the setting limits.

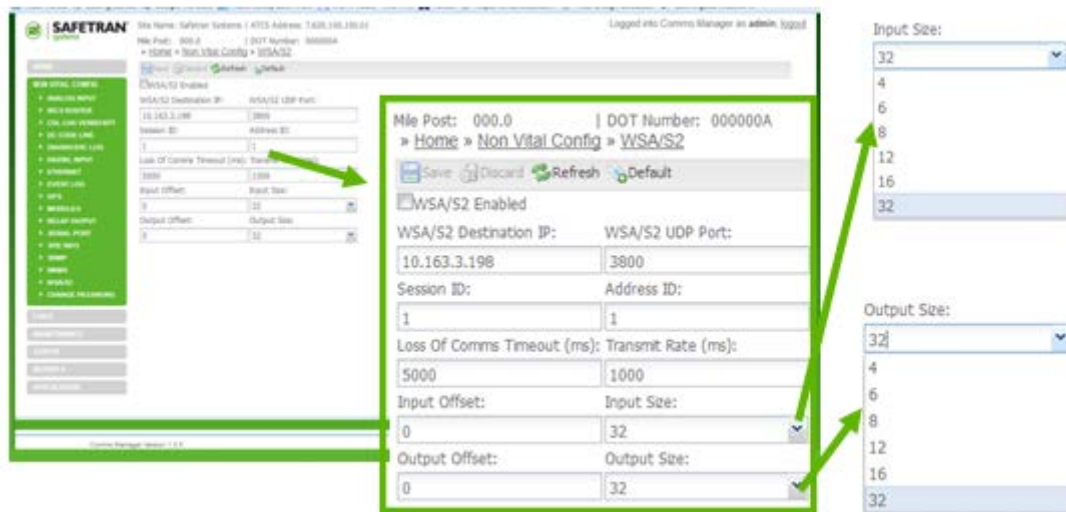

Figure 4-57 WSA/S2 Parameters

Table 4-10 WSA/S2 Parameters

Parameter Name	Range	Default	Description
WSA/S2 Enabled	Yes or No	No	Set to Yes to enable the WSA/S2 protocol functions.
WSA/S2 UDP Port	0..65535	3800	The UDP port number used to send and receive WSA/S2 messages.
WSA/S2 Destination IP	<IPv4 Address>	192.168.1.1	The IP address of the Westrace Freight unit.
Session ID	1..255	1	An identifier associated with the session. Must match the ID provided in WTRF.
Address ID	1..62	1	The WSA/S2 address of the WTRF.
Loss of Comms Timeout	100..30000 (ms) in 100 ms increments	5000 (ms)	If no WSA/S2 messages are received within this timeout, the Comms Manager will declare the session as "failed".
Transmit Rate	100..30000 (ms) in 100 ms increments	1000 (ms)	The rate at which the Comms Manager will transmit WSA/S2 control messages to the destination system.
Input Offset	0..28	0	Offset, in bytes, into the input logic states ("I" bits) of the ladder logic bitmap to copy the received WSA/S2 logic states.
Input Size	4, 6, 8, 12, 16, or 32	4	The size, in bytes, of data to copy from the received WSA/S2 logic states. Selected from drop down menu.
Output Offset	0..28	0	Offset, in bytes, into the output logic states ("O" bits) of the ladder logic bitmap to copy the sent WSA/S2 logic states.
Output Size	4, 6, 8, 12, 16, or 32	4	The size, in bytes, to copy the sent WSA/S2 logic states. Selected from drop down menu.

4.3.4.16 Change Password

A password may be set up in conjunction with a CDL application to limit access to system parameters. A default password (**772**) is programmed into the Communications Manager. This password is not used unless incorporated into a CDL program. To change the password, click on **CHANGE PASSWORD** on the Non-Vital configuration menu.



Figure 4-58 Change Password Sub-menu

The Change Password screen will appear as shown in the figure below.

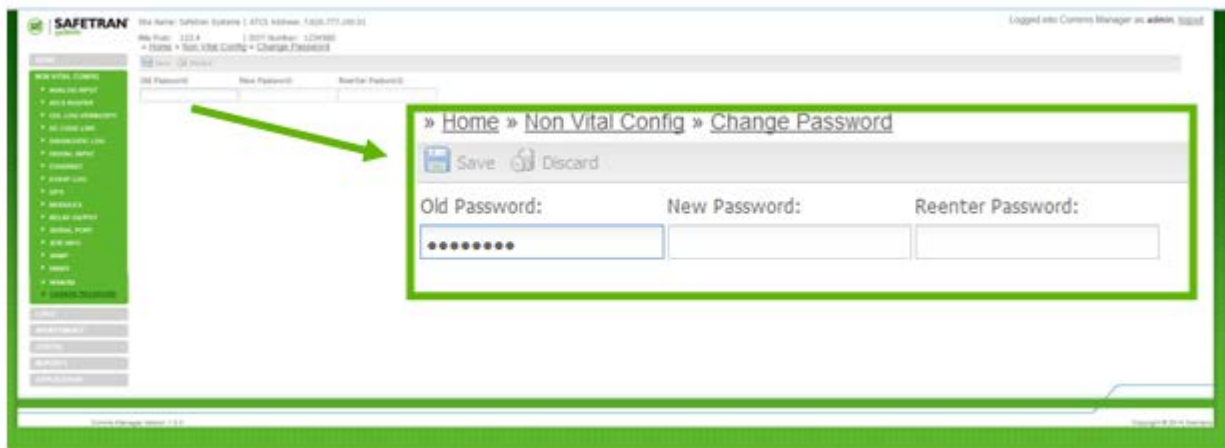

Figure 4-59 Change Password Screen

Using the procedure outlined in the figure below, a new password will be saved into the Communications Manager.

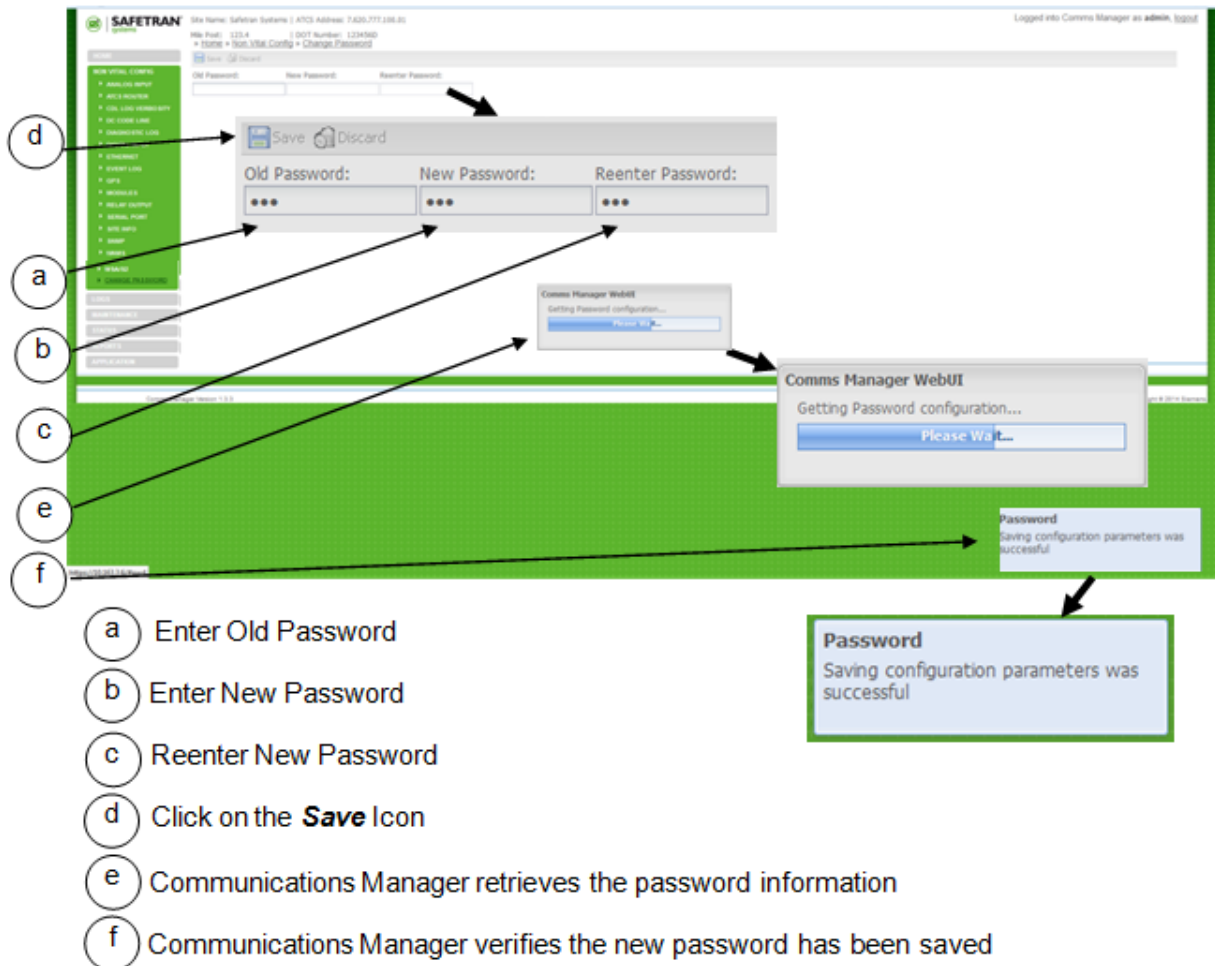

Figure 4-60 Change Password Procedure

4.3.5 Logs

The WebUI Logs Menu provides sub menus to the Diagnostic Log, Event Log, and CDL Log.

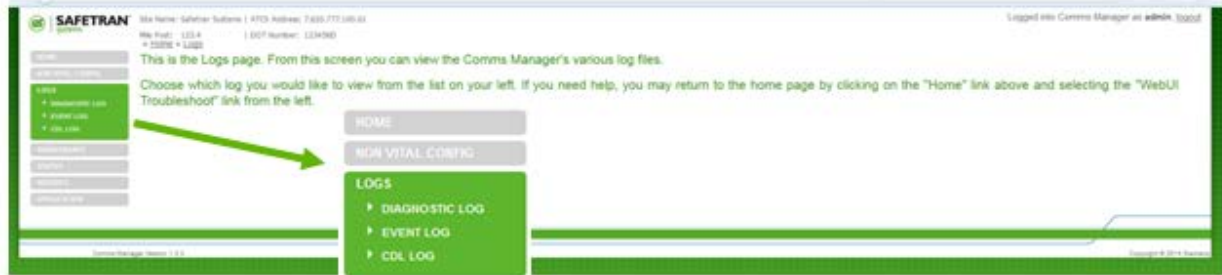

Figure 4-61 Logs Menu

4.3.5.1 Diagnostic Log

Click on the **Diagnostic Log** sub-menu to bring up the Diagnostic Log page.



Figure 4-62 Diagnostic Log Menu

- **Diagnostic Log – Basic View**

The Diagnostic Log defaults to the **Basic View** (Figure 4-63).

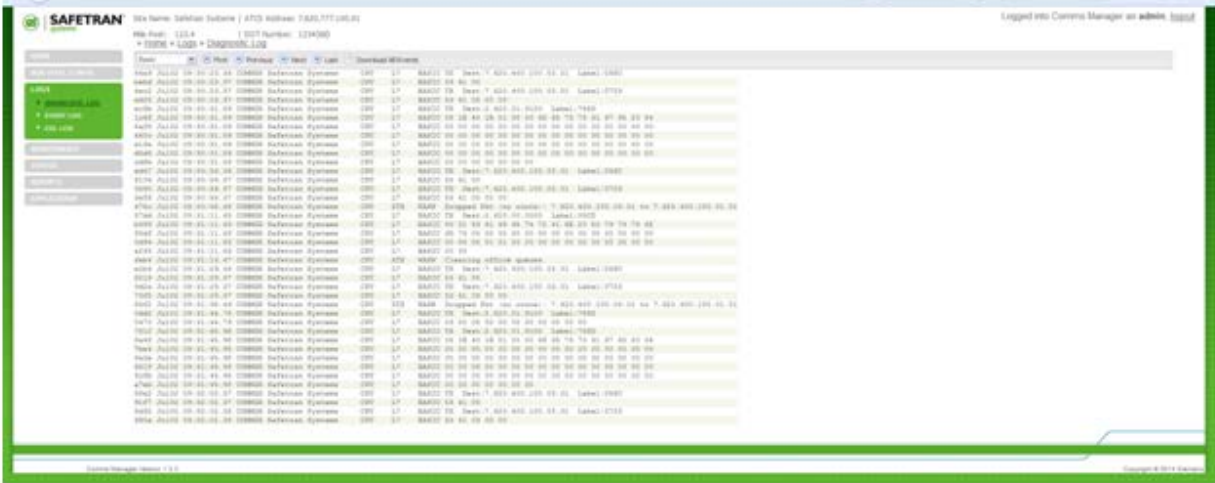
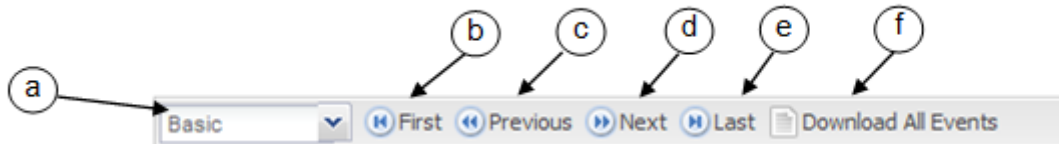

Figure 4-63 Diagnostic Log – Basic View

Buttons provided at the top of the log display allow the user to view the first events in the log, the last events in the log and to progress through the log one screen-full at a time using **Next** and **Previous** buttons. A button is also provided to download the entire log contents to a PC.



	Selection	Description
a	Search Level	Basic, Advanced, Trace Events
b	First	Events at the beginning of the log are displayed.
c	Previous	Selects the previous group of events.
d	Next	Selects the next group of events.
e	Last	Events at the end of the log are displayed.
f	Download All Events	Downloads all events to text file.

Figure 4-64 Diagnostic Log Basic View Navigation Buttons

- **Diagnostic Log – Advanced View**

The **Advanced** view provides the same navigation buttons as the Basic view (Figure 4-65). However, below these buttons are additional buttons for data entry fields that allow the log to be searched within date and time parameters.

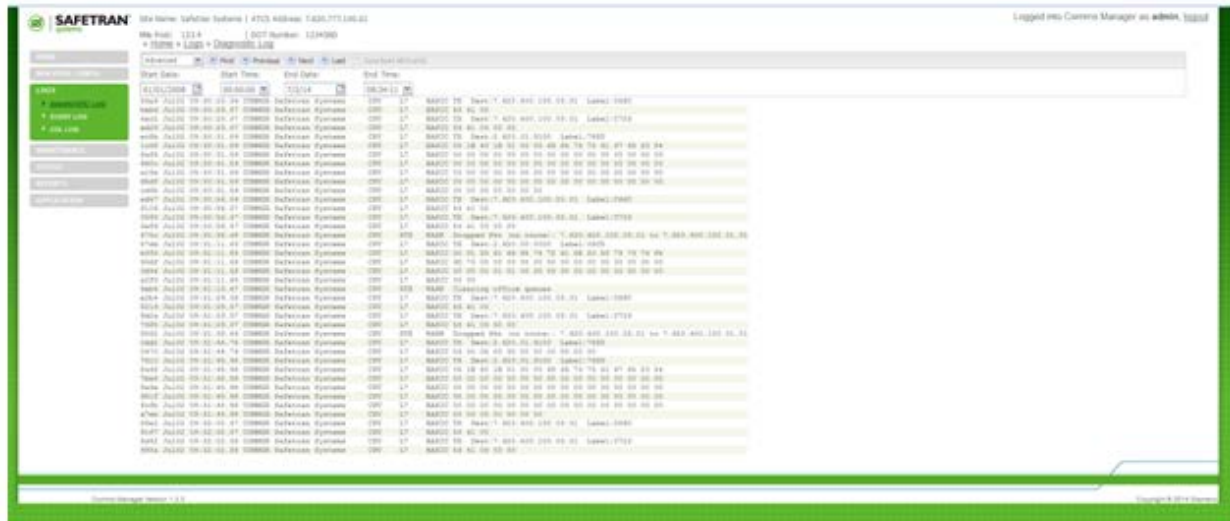

Figure 4-65 Diagnostic Log – Advanced View

In the **Advanced** Mode, dates can be entered either directly in the date fields or the calendar icon at the right end of the date field can be selected to display a calendar. The time fields are similar except that a drop down list provides a list of times or the time can be entered directly in the field.

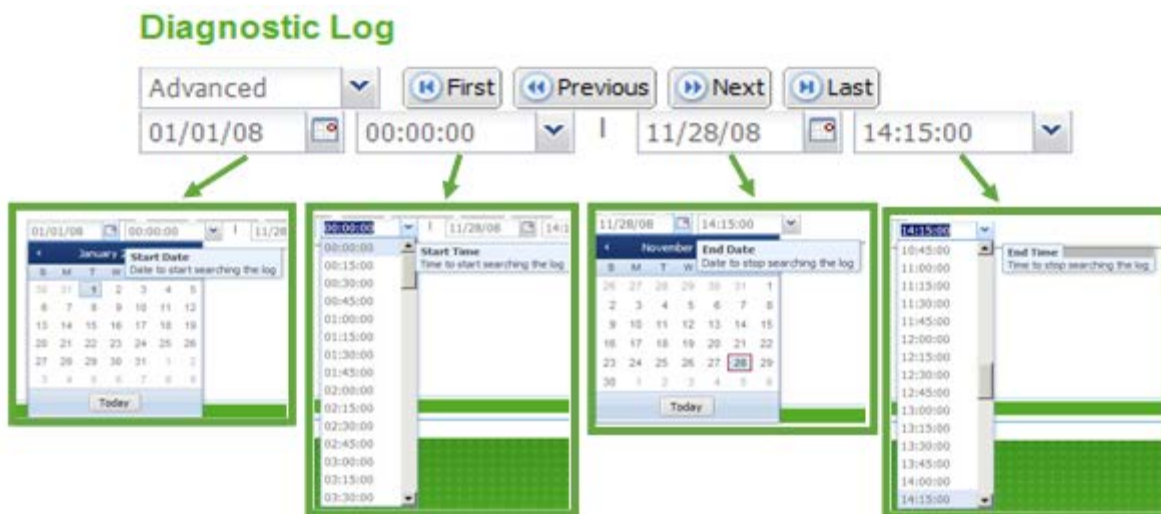

Figure 4-66 Diagnostic Log Advanced View Navigation Buttons

- **Diagnostic Log – Trace Events View**

The final selection from the view drop down list is **Trace Events** (Figure 4-67). Select this view to see events as they are logged into the Diagnostic Log. This screen refreshes every 5 seconds so there is a short delay between the time the event occurs and it is displayed. As the screen becomes full, the screen will scroll up to show new events.

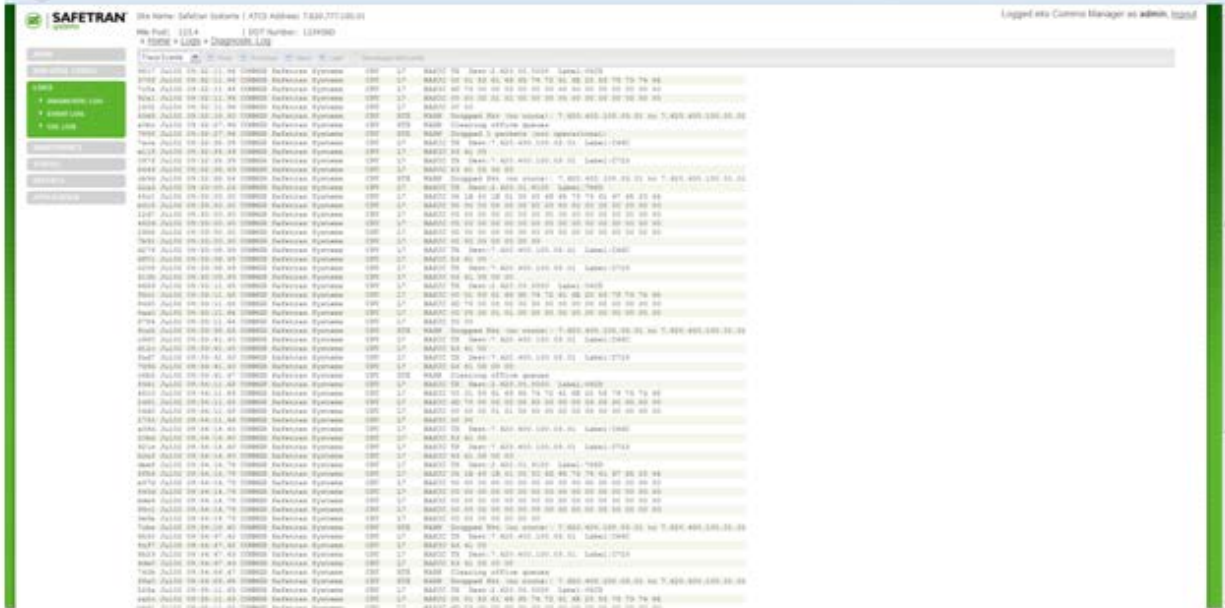

Figure 4-67 Diagnostic Log – Trace Events

4.3.5.2 Event Log

Click on the **Event Log** sub-menu to bring up the Event Log Page.



Figure 4-68 Event Log Menu

- Event Log – Basic View

The Event Log defaults to the **Basic** view.

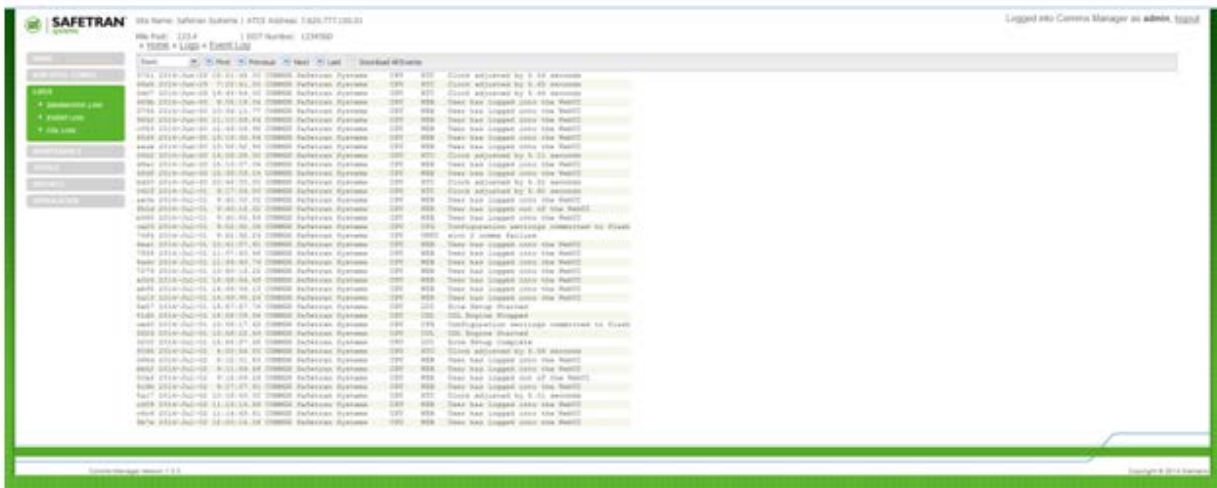
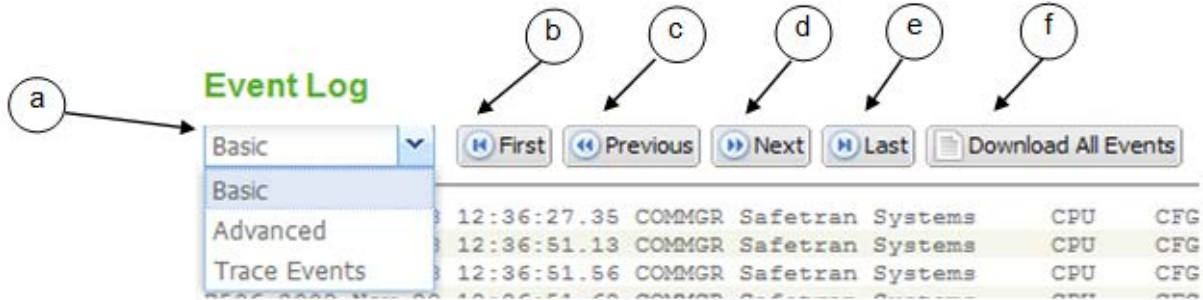

Figure 4-69 Event Log Menu Basic View

Buttons provided at the top of the log display allow the user to view the **First** events in the log, the **Last** events in the log. The **Next** and **Previous** buttons navigate through events a screen full at a time. A button is also provided to **Download All Events** in the log contents to a PC.



	Selection	Description
a	Search Level	Basic, Advanced, Trace Events
b	First	Events at the beginning of the log are displayed.
c	Previous	Selects the previous group of events.
d	Next	Selects the next group of events.
e	Last	Events at the end of the log are displayed.
f	Download All Events	Downloads all events to text file.

Figure 4-70 Event Log Basic View Navigation Buttons

- **Event Log – Advanced View**

The **Advanced** view provides the same navigation buttons as the **Basic** view (Figure 4-71). Below these buttons are additional buttons for entry fields that allow the log to be searched within date and time parameters.

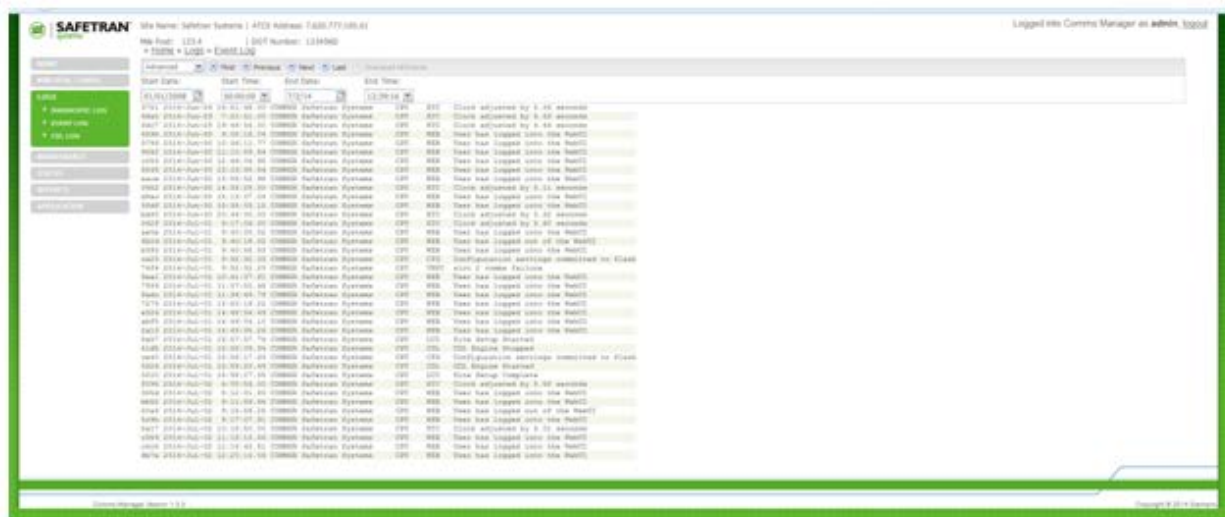

Figure 4-71 Event Log – Advanced View

In the **Advanced** view, dates can be entered either directly in the date fields or the calendar icon at the right end of the date field can be selected to display a calendar. The time fields are similar except that a drop down list provides a list of times or the time can be entered directly in the field.

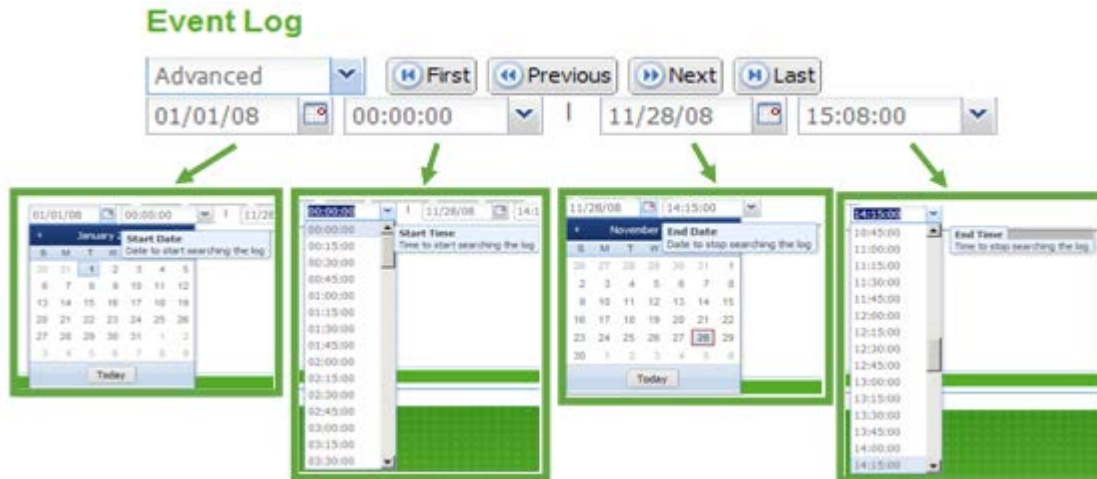

Figure 4-72 Event Log Advanced View Navigation Buttons

- Event Log – Trace Event View



Figure 4-73 Event Log – Trace Events

4.3.5.3 CDL Log

The Communications Manager will generate a log of CDL program information. The CDL Log is generated during the compilation of a CDL program. This function is only useful to the Application Engineer writing CDL Logic.

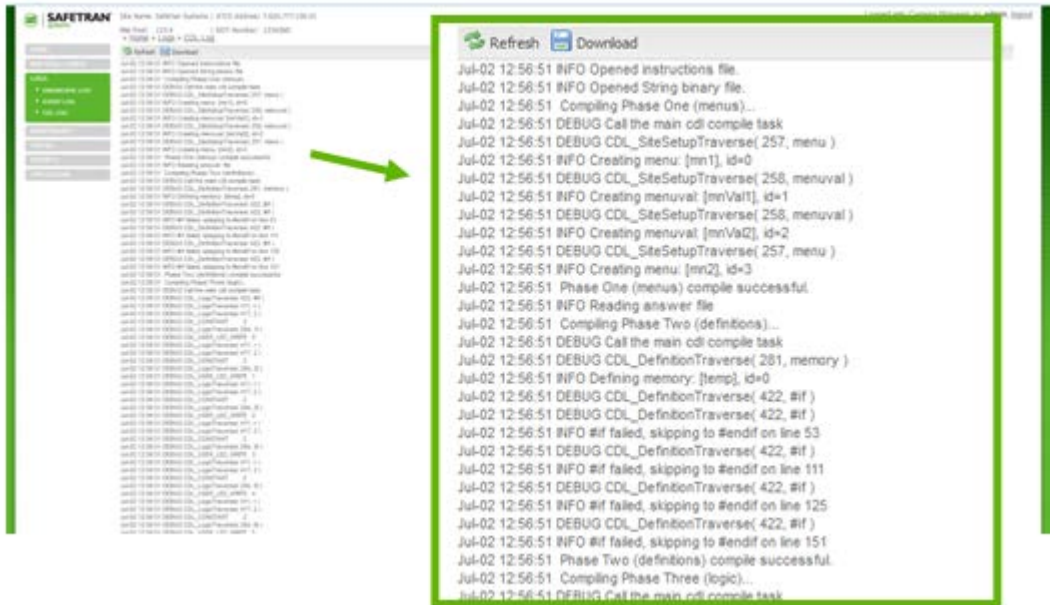

Figure 4-74 CDL Log

4.3.6 Maintenance

The Maintenance Menu can be accessed by clicking on the *Maintenance* menu.

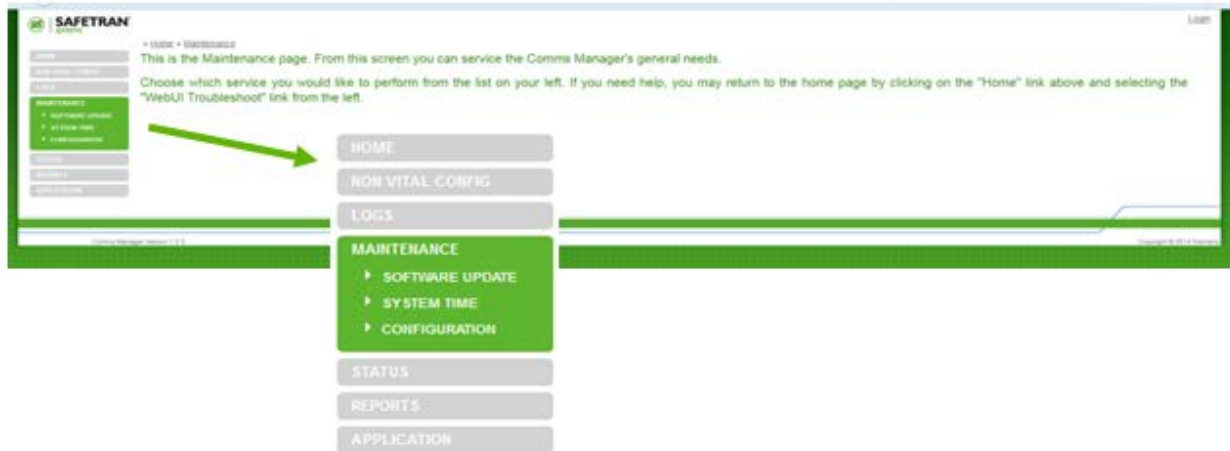

Figure 4-75 Maintenance Menu

4.3.6.1 Software Upgrade

The following is the procedure for software upgrade using Web UI. First, click on **SOFTWARE UPDATE**. Then, follow the steps below.

a Press **BROWSE** to software file.

b Locate file, highlight, and press **OPEN**.

c Click on **UPLOAD**

d Uploading **cm_mef_1.11.1N.tgz** to Comms Manager...

The file will upload to **Communications Manager**

e Click on **YES** to upgrade software.

f The **Communications Manager** will monitor the upgrade progress.

g **Communications Manager** will request **OK** to Reboot when upgrade is completed.

h **Communications Manager** will reboot. Click **OK** to refresh your screen and login.

Figure 4-76 Software Upgrade Procedure

4.3.6.2 System Time

The System Time can be set using Web UI. Communications Manager derives its time source from manual setting, network system time, or GPS if the receiver is enabled and a GPS antenna is installed. First, click on **SYSTEM TIME**. Then, to manually set the time click on the **Date** drop menu and either select the date from the calendar or manually type it in using the proper format. Click on the **Time** drop menu and either select the time or type it in using the proper format. Then, click **Set Time** to save the entry. To set Communications Manager to the Network Time, simply click on **Computer Time** icon. The computer date and time will display in the Time Window. Click the **Set Time** button to set the time.

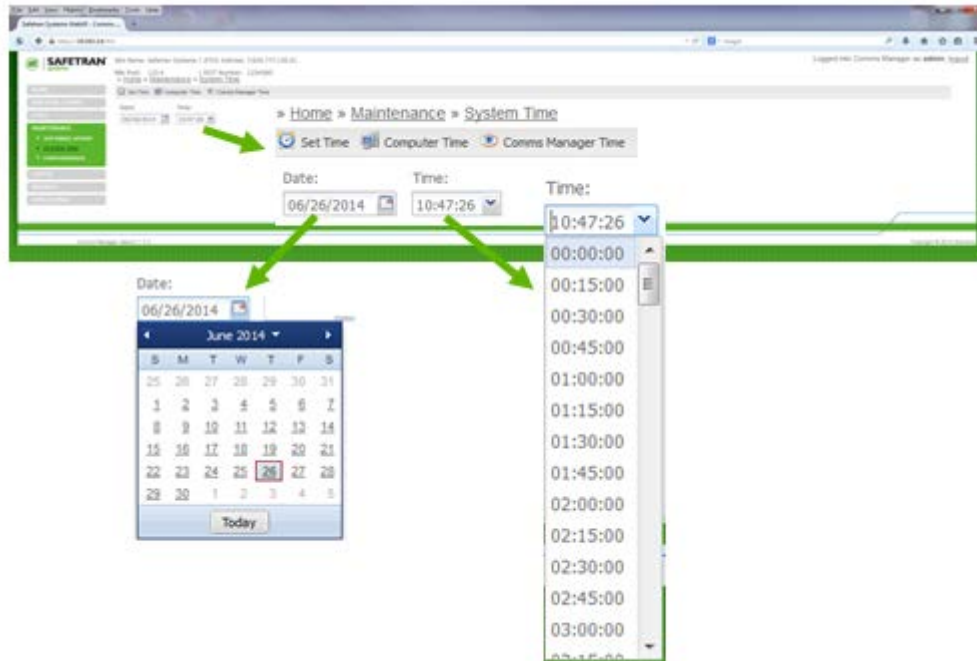

Figure 4-77 Maintenance Menu – Setting System Time

4.3.6.3 Configuration

The Communication Manager's configuration can be downloaded and saved to a computer file. Also, a configuration file can be uploaded and installed into the Communications Manager. The following procedures detail the processes.



Figure 4-78 Maintenance Menu – Configuration

- **Downloading a Configuration File**

Click on the **Configuration** sub-menu on the Maintenance menu. The following procedure is used to download the Configuration file.

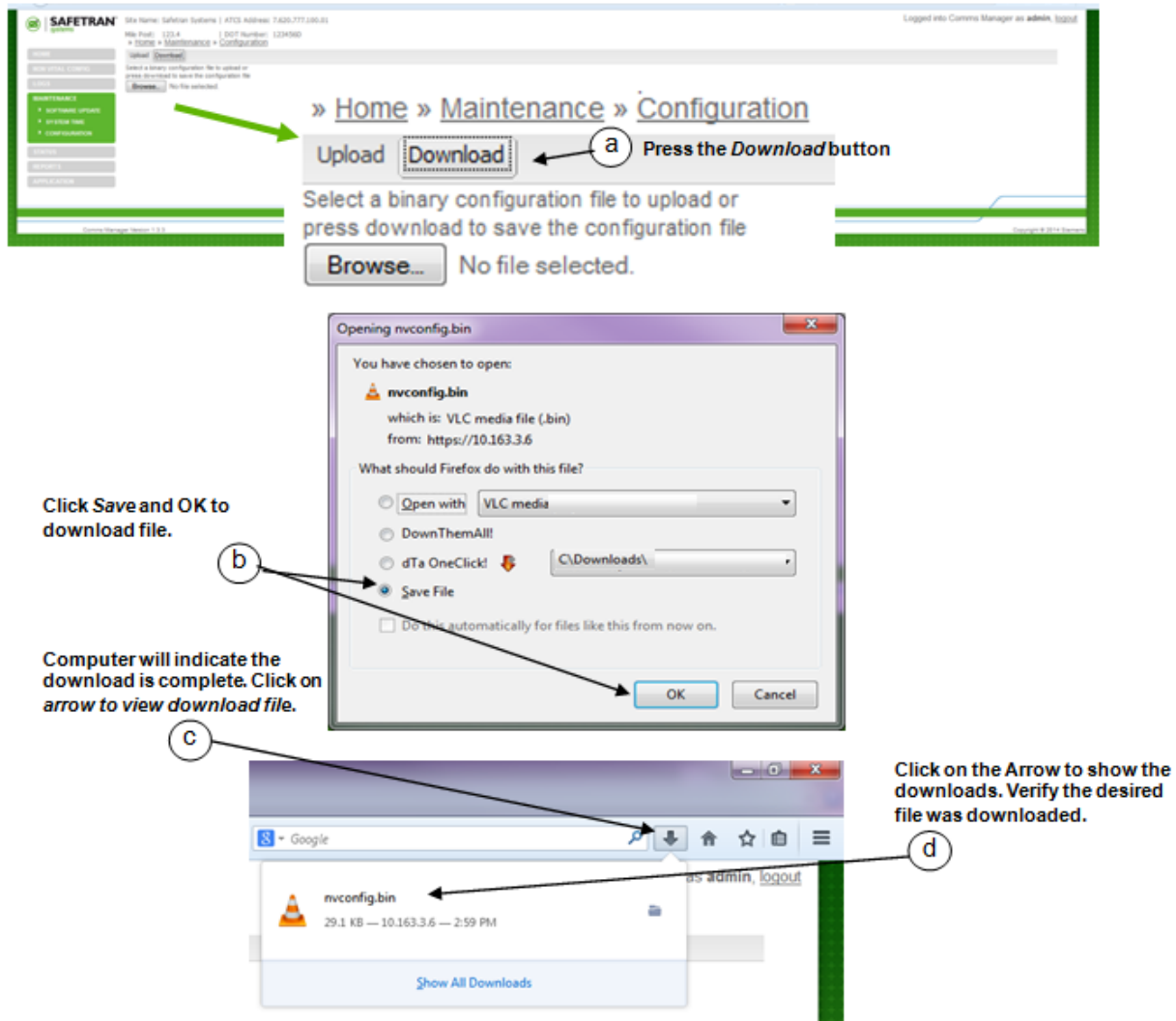

Figure 4-79 Downloading the Configuration File

- **Uploading a Configuration File**

The figure below details the Configuration Uploading process in order to save a new configuration file to ECD (flash memory).

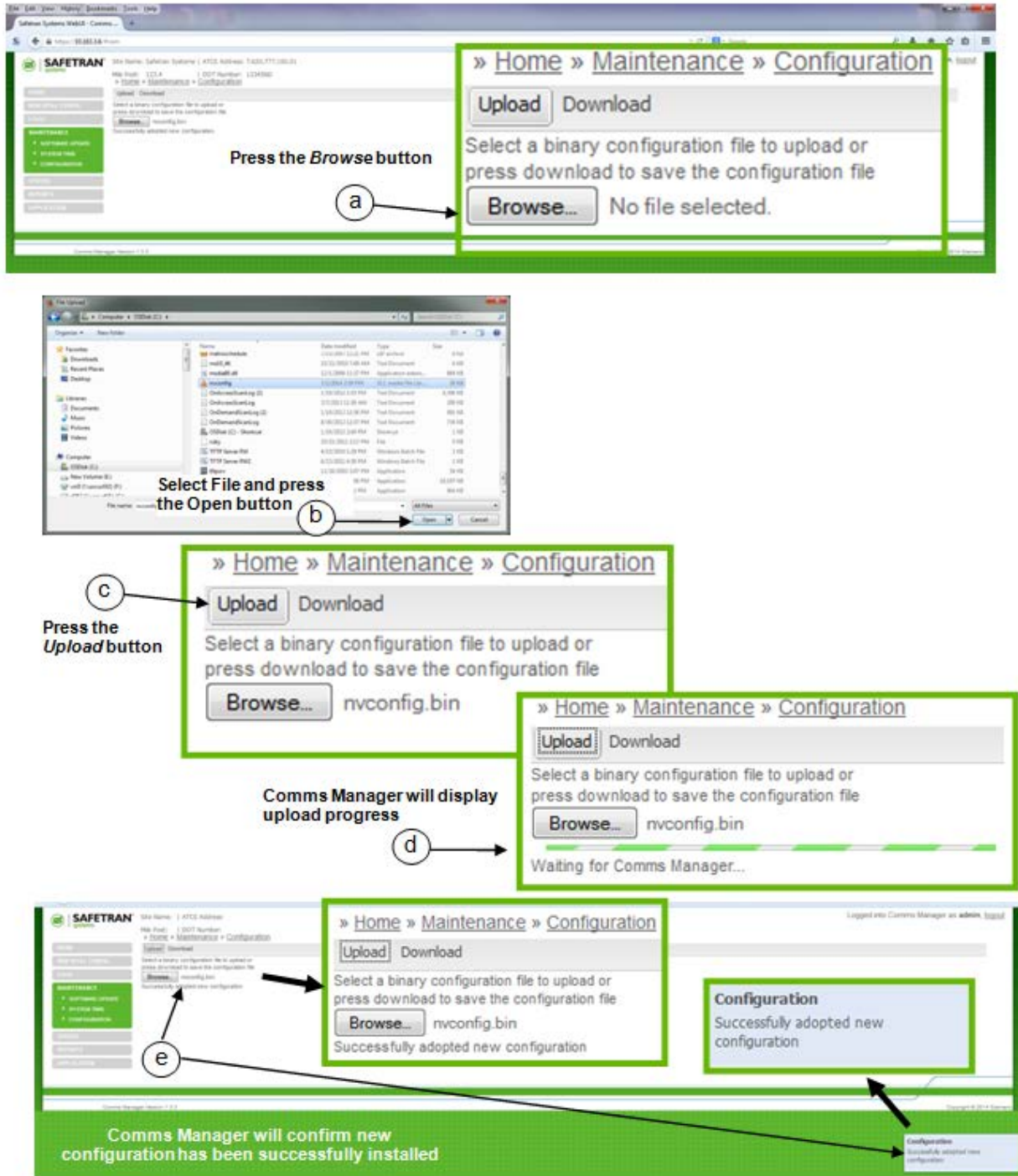

Figure 4-80 Uploading the Configuration File

4.3.7 Status

The Status Menu is accessed by clicking on the **Status** interactive text on the Menu. The Status Menu has eleven sub-menus. Each sub-menu provides a live status screen for the application selected.



Figure 4-81 Status Menu

4.3.7.1 Status Menu - GPS

Selecting the **GPS** sub-menu will display the GPS information as shown below.



Figure 4-82 GPS Status

NOTE

NOTE
The GPS feature is no longer available in Communications Manager Model 53475 Revision C3 or later.

4.3.7.2 Status Menu – I/O

Selecting the *I/O* sub-menu displays the Relay Out, Analog Input, Ground Fault Tester (GFT), and Digital Input status as shown in the figure below.

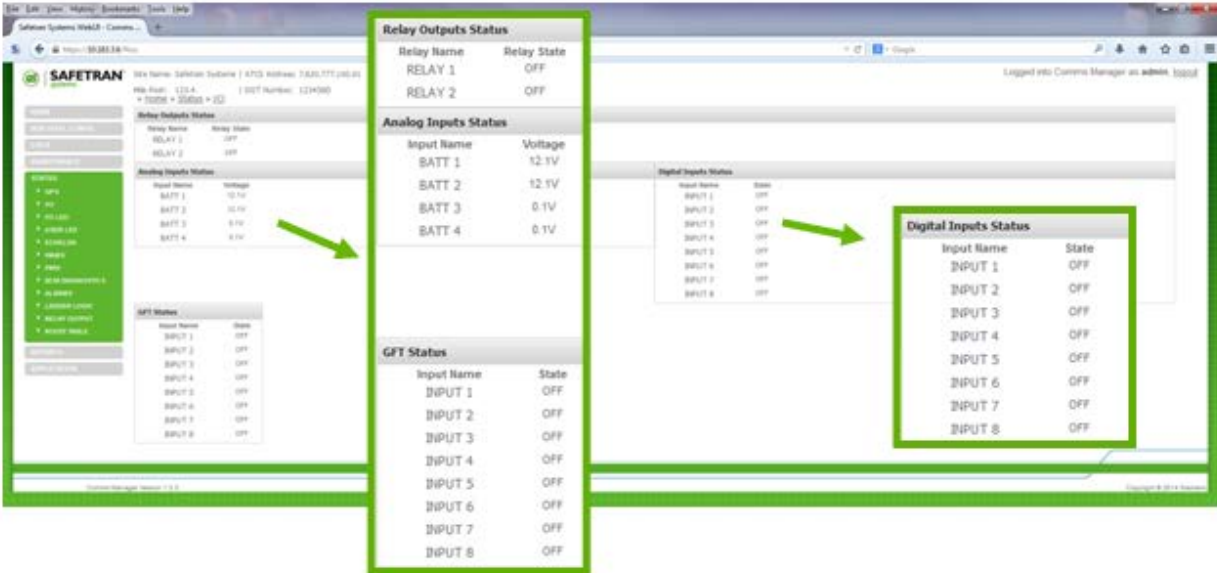

Figure 4-83 I/O Status

4.3.7.3 Status Menu – I/O LED

Selecting the *I/O LED* sub-menu will display the Input and Output LED status information. The *I/O LED* status provides information of the live status of the Communications Manager's **Digital**, **Analog**, and **Relay Output** LEDs. The *I/O LED* status will identify the **Input Name** as well as the **LED indication state**, whether it is **ON**, **OFF**, or **TOGGLING**.

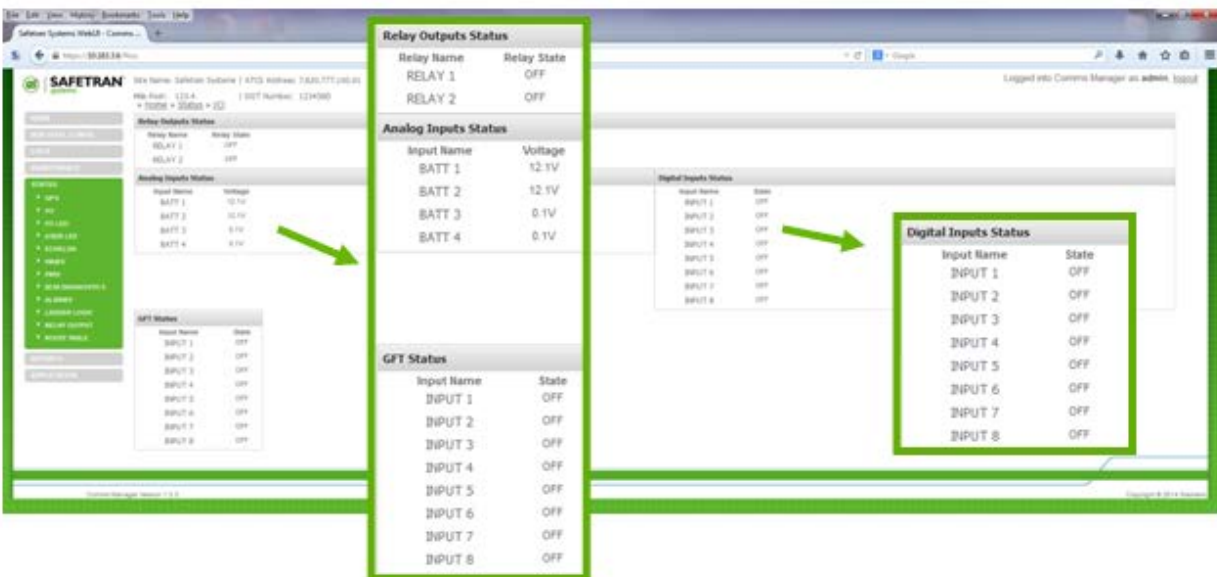

Figure 4-84 I/O LED Status

4.3.7.4 Status Menu - User LED

Selecting the *User LED* sub-menu will display the *User LED* live status. The *User LED* status will identify the *Input Name* as well as the *LED indication state*.

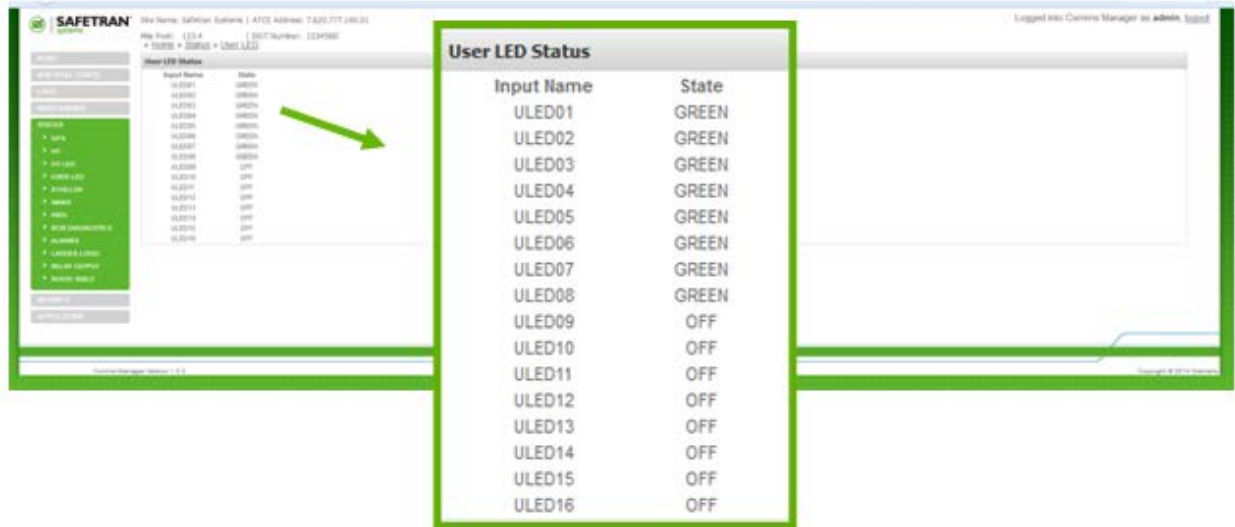

Figure 4-85 User LED Status

4.3.7.5 Status Menu – Echelon®

Selecting the *Echelon* sub-menu will display the status of the 16 Echelon Nodes, listing the *Slot Number*, *Module Name*, and *Status*. The figure below displays the Echelon screen.

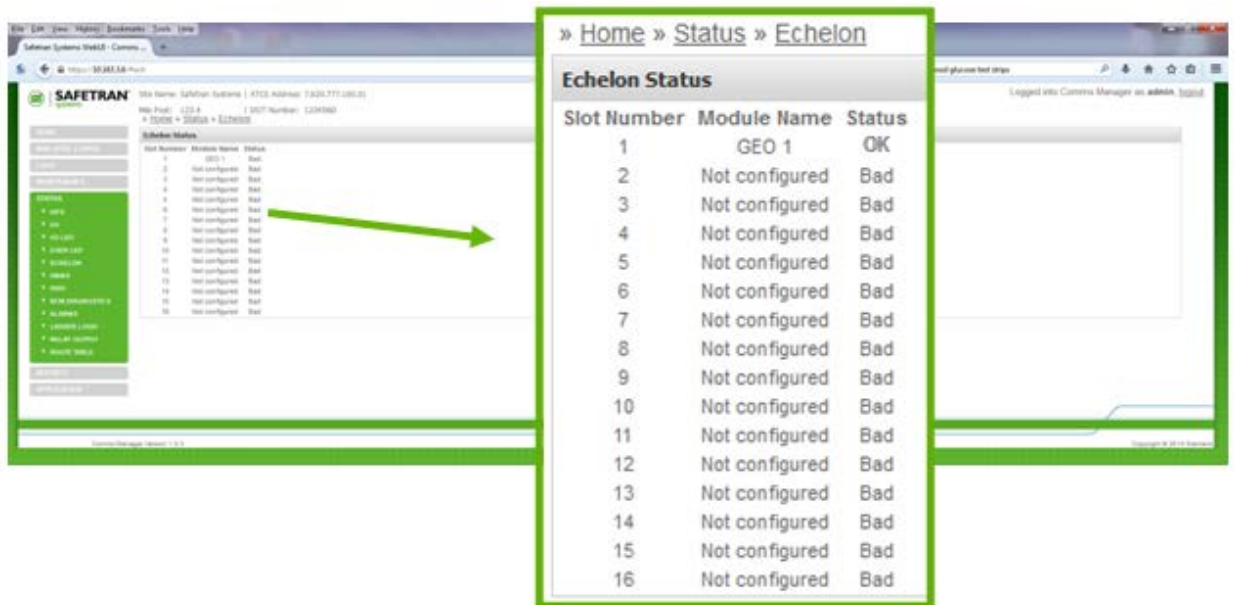

Figure 4-86 Echelon® Node Status

4.3.7.6 Status Menu – WAMS

Selecting the **WAMS** sub-menu displays the WAMS Test Packet screen. Click on the **Send WAMS Test Packet** button. A test packet will be sent to WAMS which will respond with an acknowledge message. If the acknowledge is successfully received a message will be displayed "**WAMS Test Packet Status OK**". If the acknowledge is not successfully received, a message will be displayed "**WAMS Test Packet Status NOK**".

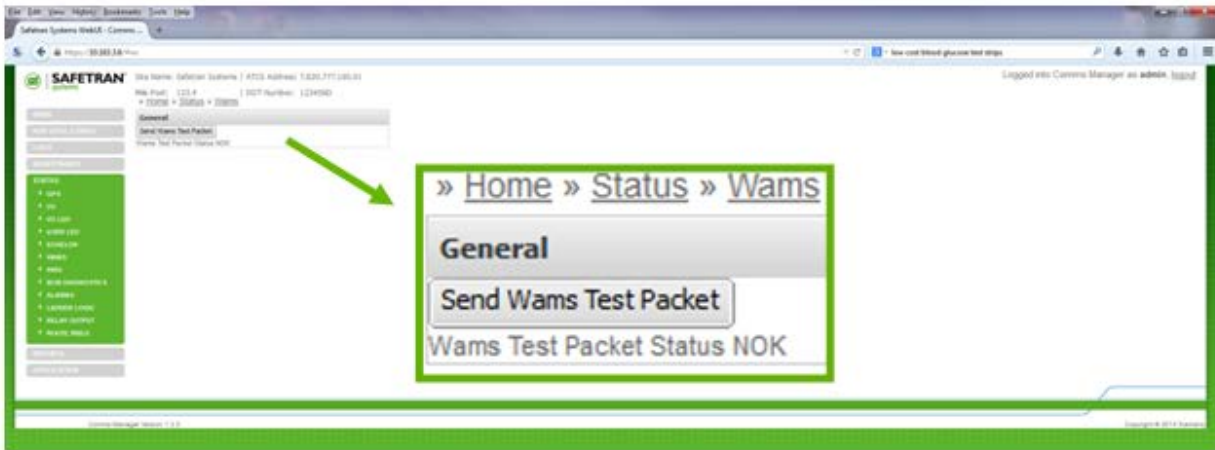

Figure 4-87 WAMS Status

4.3.7.7 Status Menu - Path

Selection of the **Path** sub-menu displays the Communications Manager's path status information and their operational status. The figure below shows the Path information screen.

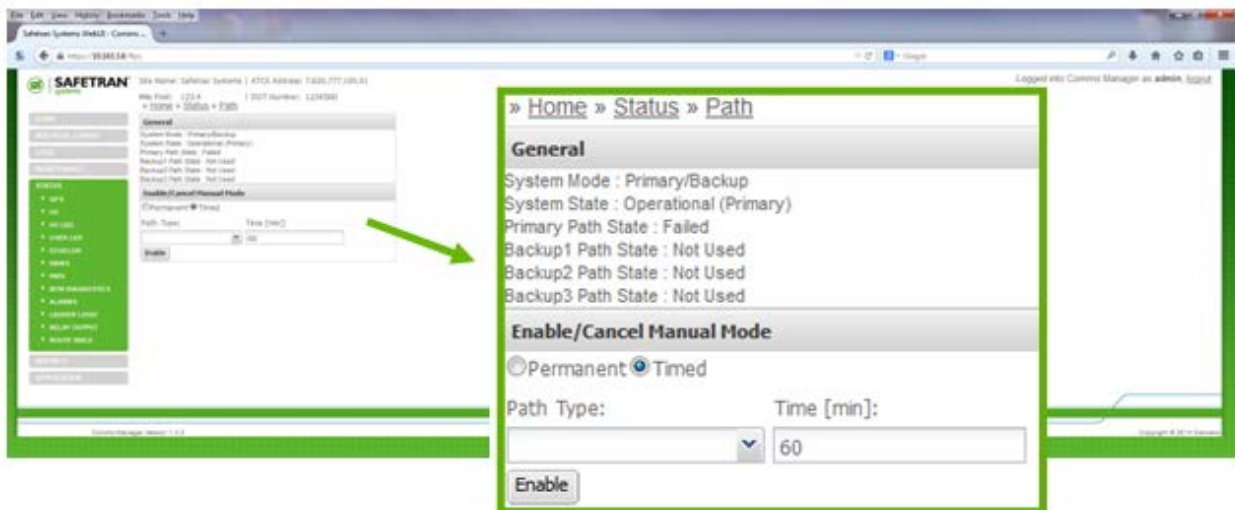

Figure 4-88 Path Status

4.3.7.8 Status Menu – BCM Diagnostics

The **BCM Diagnostics** selection on the Status Menu opens the BCM Diagnostics window which consists of a list of buttons to interrogate and test the BCM module. Click on each button to view the status of that function.

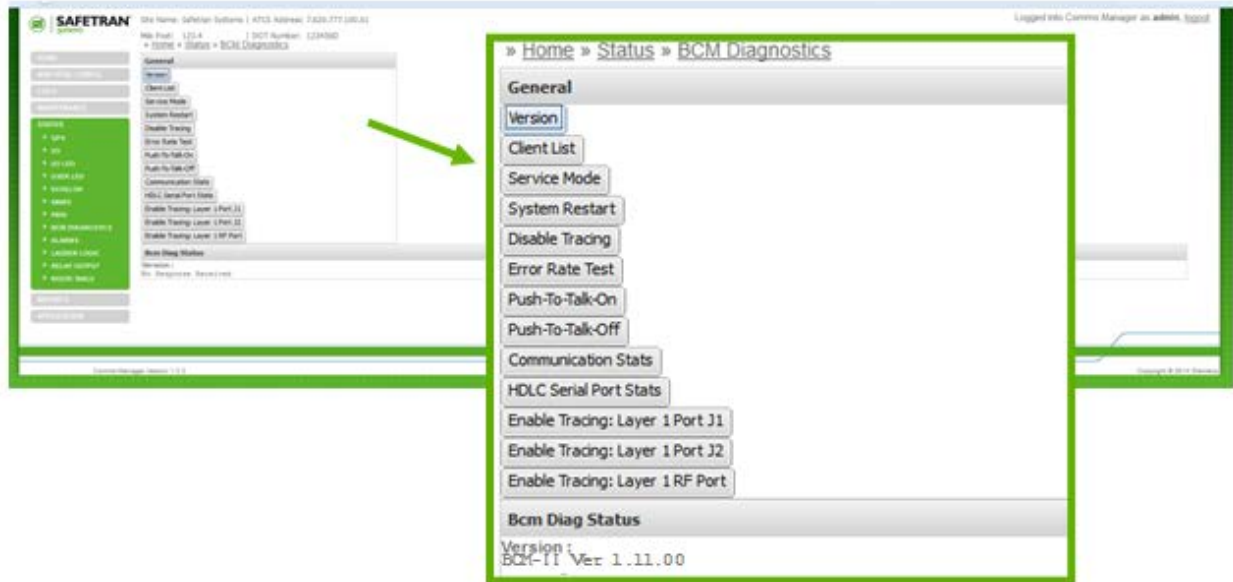

Figure 4-89 BCM Diagnostics

4.3.7.9 Status Menu – Alarms

The **Alarms** selection displays a list of alarms sent to WAMS or SNMP. The alarm list can be saved. Alarms can be selected and disabled.

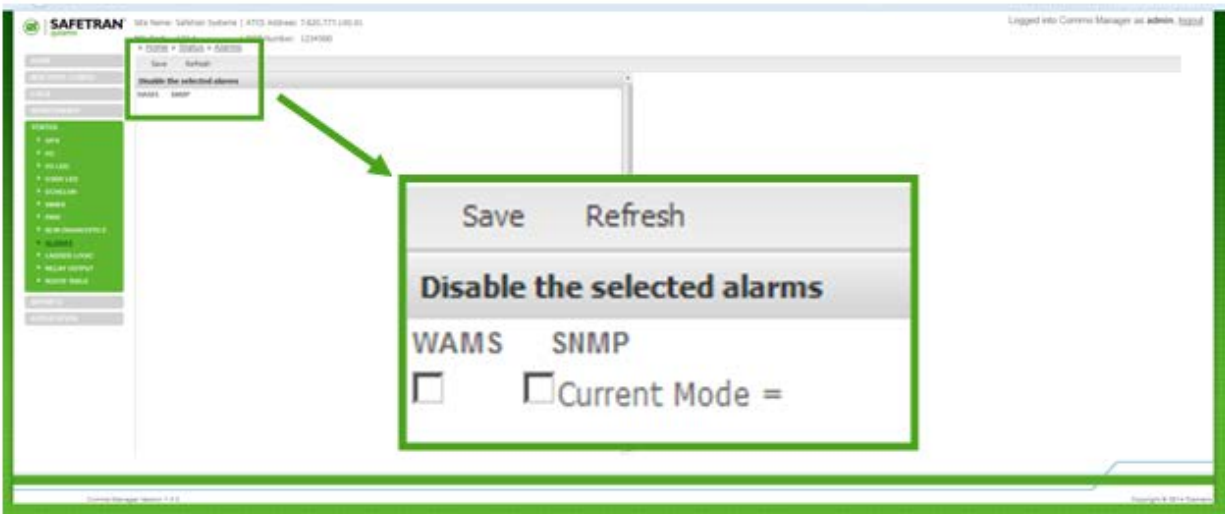

Figure 4-90 Status Menu - Alarms

4.3.7.10 Status Menu – Ladder Logic

Selection of **Ladder Logic** on the Status Menu brings up the Ladder Logic matrix. The matrix consists of individual bitmap areas, each of which are 256 bits(32 bytes) big. If a ladder logic program is installed, the program will process specific bitmap areas, resulting in updates to various bitmap areas. The net result of a ladder logic program’s processing is the updating of bitmap areas that cause output messages to be generated to office system or CDL engine.

The ladder logic matrix is dynamically updated as the input and output statuses that the bitmap areas represent change. The matrix may also be manually changed by double-clicking on an individual bit. This will cause its value to change from 1 to 0 or 0 to 1. Then, upon either a dynamic or manual change to ladder logic matrix, ladder logic program will automatically process the ladder logic matrix.

The bitmap areas represent the various functions used in the processing of input and output data statuses. These functions include office indication bits, office control bits, GEO control bits, GEO indication bits, executive bits, etc.

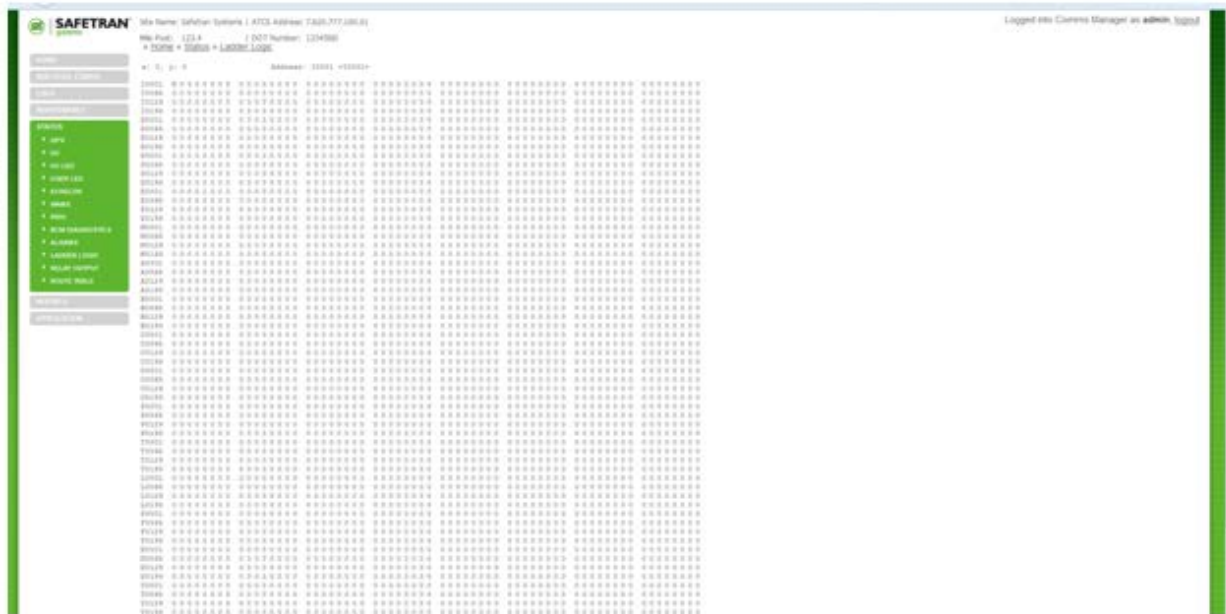

Figure 4-91 Status Menu – Ladder Logic

4.3.7.11 Status Menu – Relay Outputs

The **Relay Output** selection of the Status Menu shows the present status of the relay outputs. The user can also change the relay output state to one of three selections, **ON**, **OFF**, and **TOGGLING**. The figure below details the procedure to change the relay states. As a relay is driven to the selected output state, the 'Present State of Relays' window will be update with the new output state. For TOGGLING output state, the relay will be toggled according the relay's configured toggle rate.

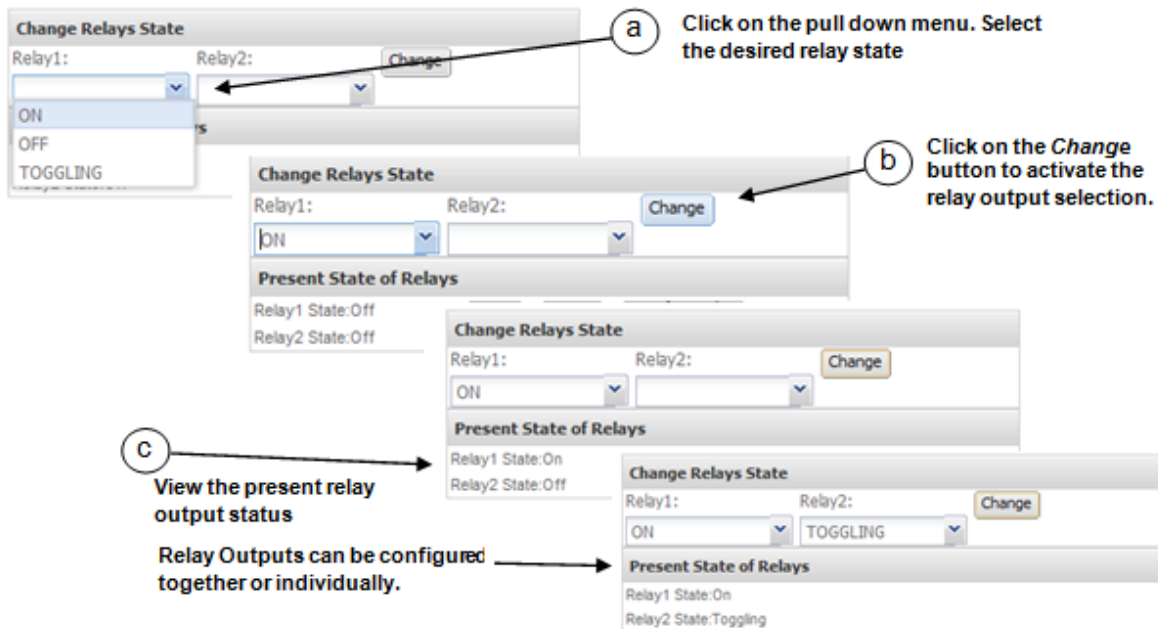
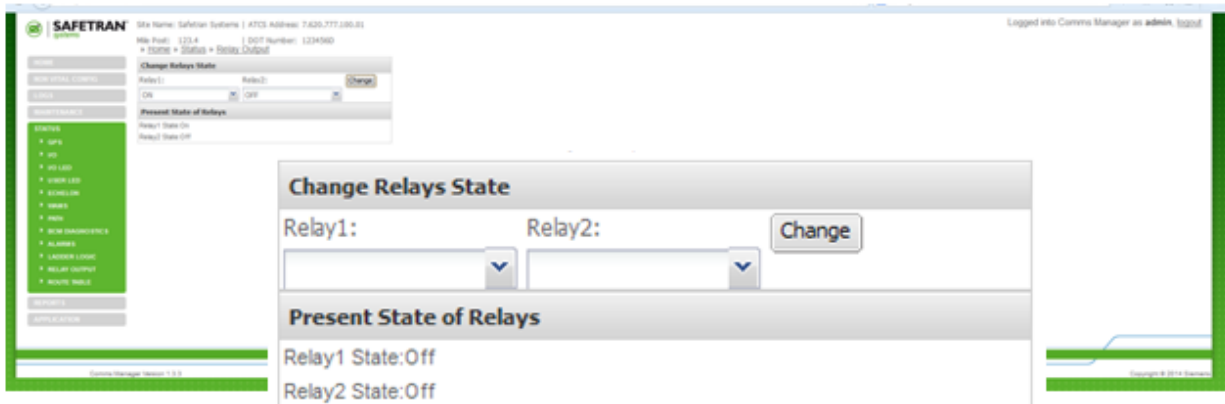

Figure 4-92 Relay Outputs – Change Relay State

4.3.7.12 Status Menu – Route Table

The **Route Table** selection of the Status Menu displays the ATCS route table. These routes are placed in the table as ATCS messages are received from various stations using Ethernet ports, serial ports, and the Echelon port. The Table lists the **Address**, **Path Type**, **Port Number**, and **Timer Setting**.

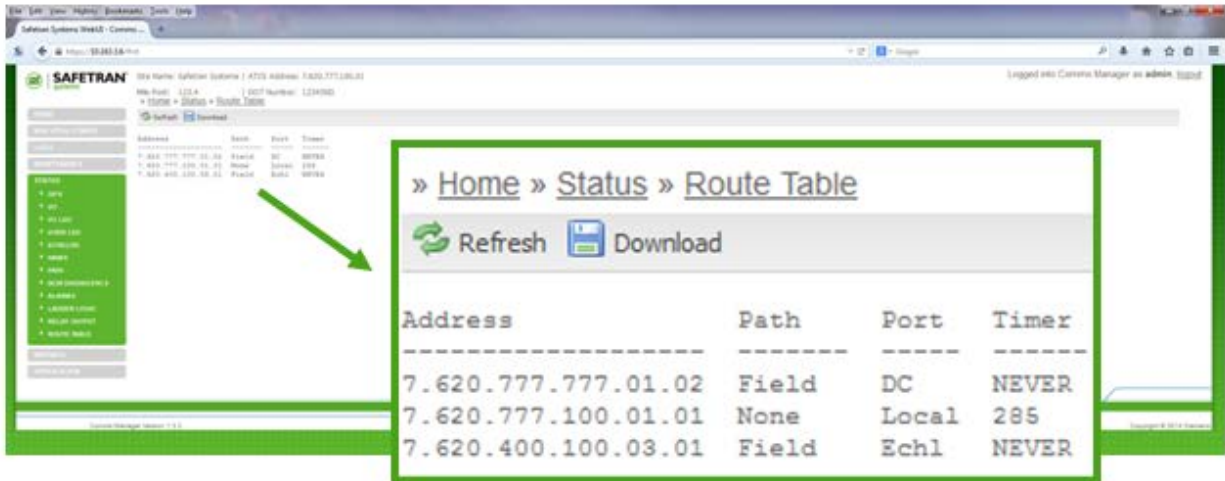

Figure 4-93 Route Table

4.3.8 Reports

Click on the **Reports** menu, two sub menus are available, **Configuration Report** and **Versions Report**.

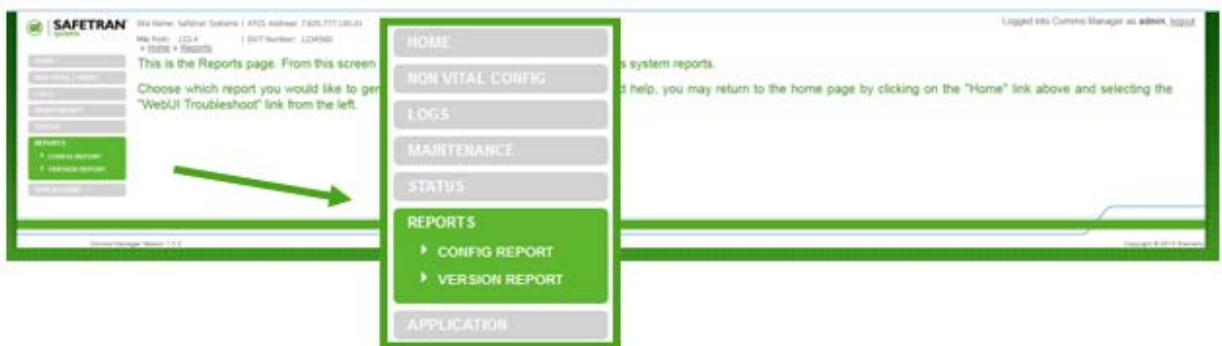

Figure 4-94 Reports Menu

4.3.8.1 Reports – Config Report

The first of the two sub-menus is the Configuration Report. To view the report information click on the **Config Report** sub-menu. The report will appear on the screen. The **Refresh** button updates the screen. The configuration report contains all the configuration parameters as they are stored on ECD (flash memory).

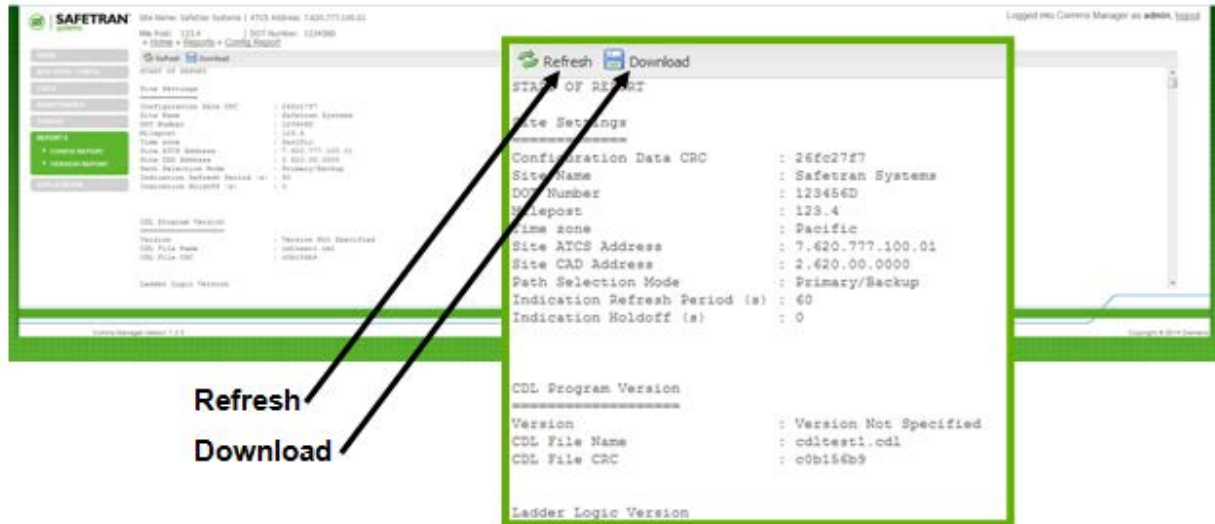

Figure 4-95 Reports Menu – Config Report

Click on the **Download** button to **Open** the file or **Save** the file to the computer as shown below.

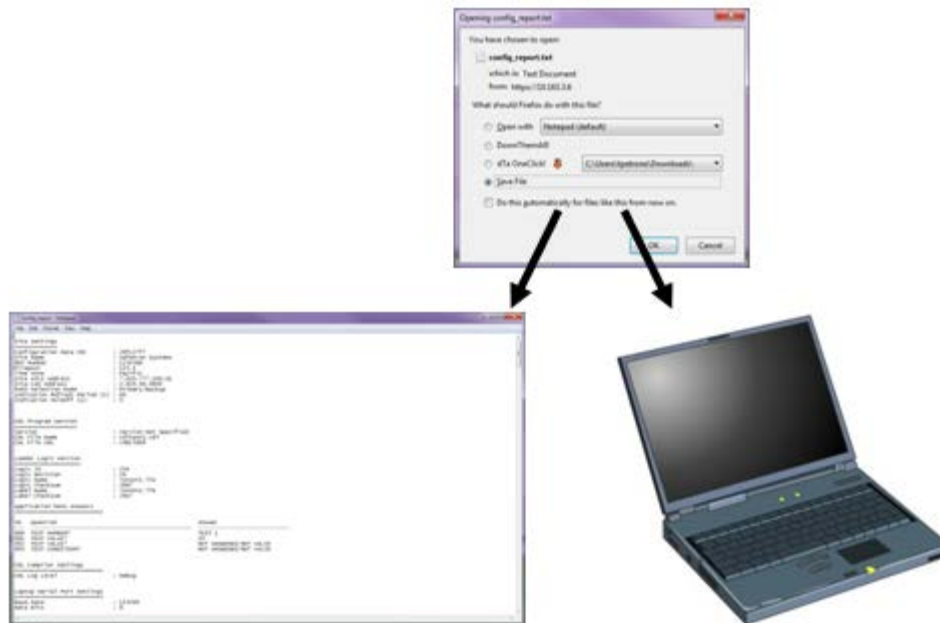

Figure 4-96 Downloading Configuration Information

4.3.8.2 Reports – Version Report

The second of the two sub-menus is the **Version Report**. To view the report information click on the **Version Report** interactive text. The report will appear on the screen. The **Refresh** button updates the screen. The version report will contain version numbers for executive software, CDL program (if installed), ladder logic program(if installed), Linux kernel, FPGA, CPLD, and hardware modules.

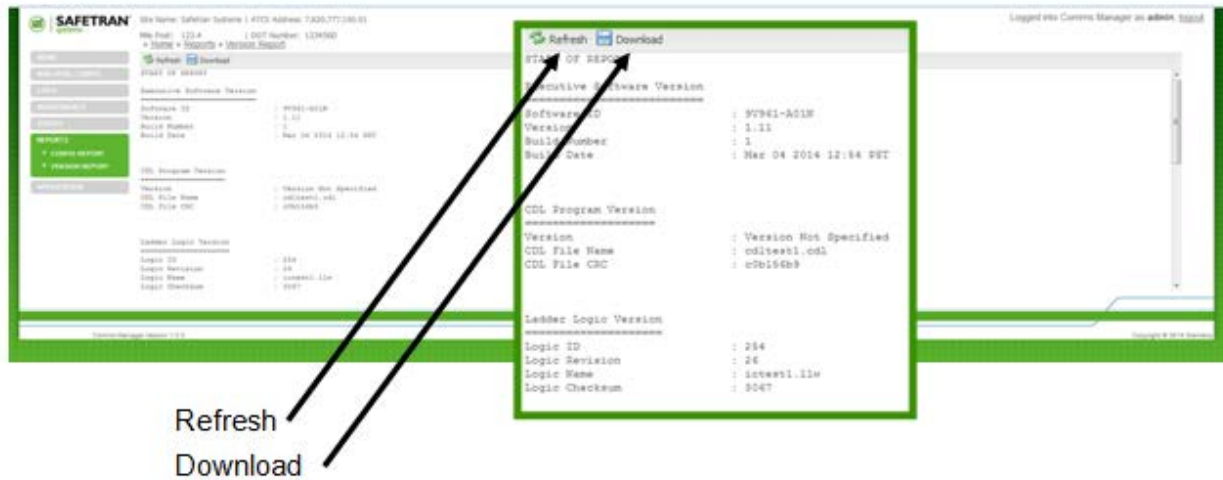

Figure 4-97 Version Report

Click on the **Download** button to **Open** the file or **Save** the file to the computer as shown below.

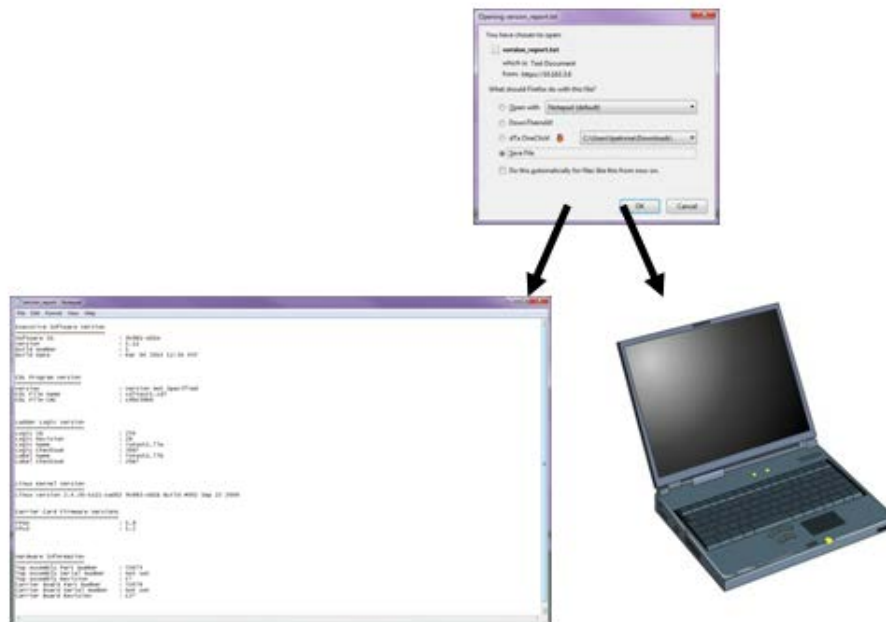

Figure 4-98 Downloading Version Report

4.3.8.3 Application

The Communications Manager is designed to support applications written in the CDL programming language. The **Application** menu is used to upload and install CDL applications and upload or remove ladder logic. The **Application** menu has three sub-menus for **Site Setup**, **Uploading Ladder Logic**, and **Upload CDL**.



Figure 4-99 Application Menu

- **Site Setup**

The Site Setup sub-menu allows the user to run Site Setup with a CDL application that has been previously installed as detailed in the Section above.



Figure 4-100 Applications – Site Setup Using CDL Application

Click on '**Start**' to run Site Setup.

» [Home](#) » [Application](#) » [Site Setup](#)

[Back](#) [Next](#) [Start](#)

When Site Setup is completed the following screen will appear. Click on '**Finish**'. Note that '**Restart**' will run the Site Setup again.

» [Home](#) » [Application](#) » [Site Setup](#)

[Back](#) [Finish](#) [Restart](#)

The CDL file will be saved to ECD's flash memory
Observe the following status window will appear in lower right corner.

Site Setup
CDL compiled successfully

- **Upload Ladder Logic**

The **Upload Ladder Logic** selection is used to manage Ladder Logic files for uploading into the Communications Manager.

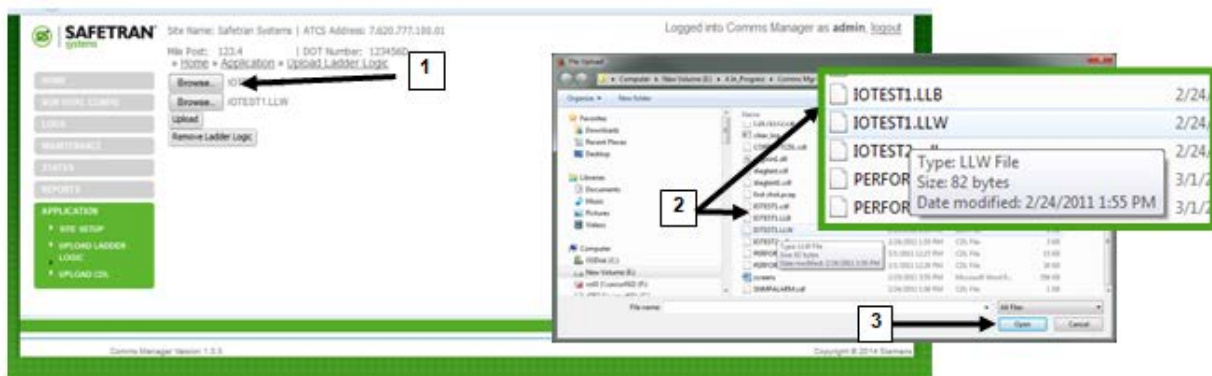

- 1 Click on upper **Browse** button.
- 2 A Choose-file-to-Upload window will appear. Select the Ladder Logic File with the .LLB extension.
- 3 Click the **Open** button.

Figure 4-101 Upload Ladder Logic Files – Select First File (LLB)

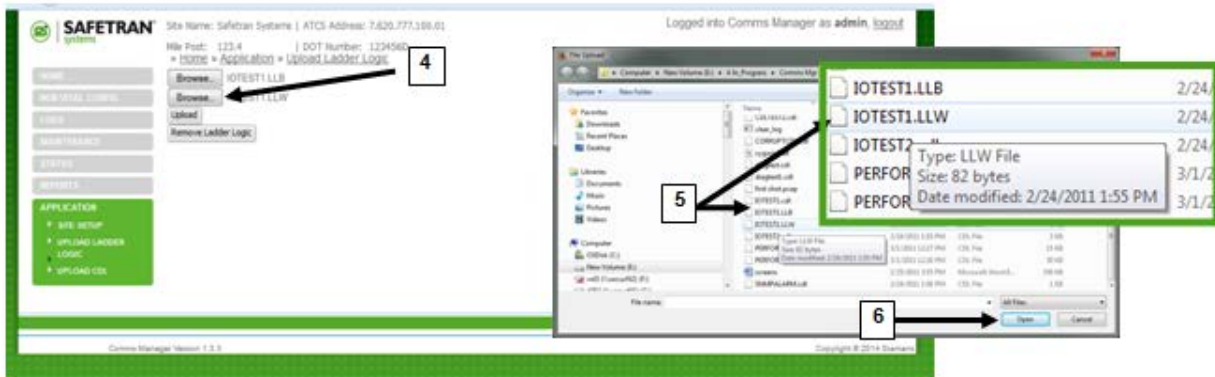

- 4 Click on lower **Browse** button.
- 5 A Choose-file-to-Upload window will appear. Select the Ladder Logic File with the .LLW extension.
- 6 Click the **Open** button.

Figure 4-102 Upload Ladder Logic Files – Select Second Files (LLW)

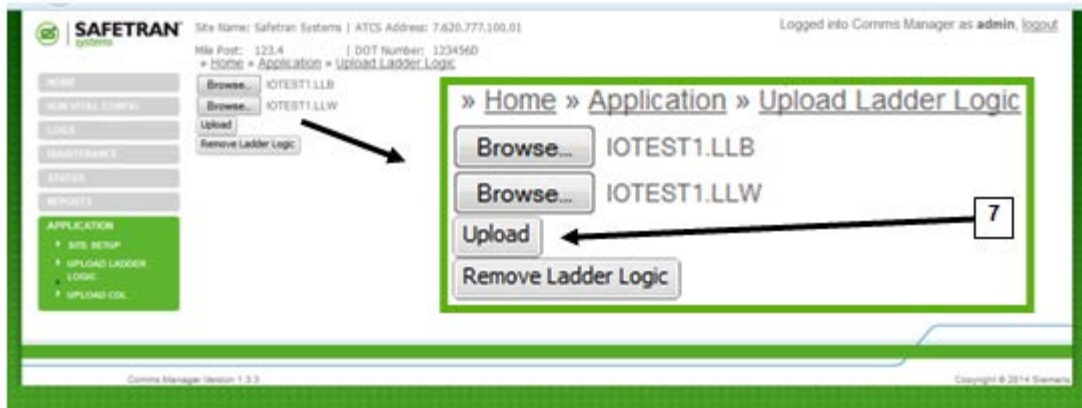

- 7 Click on the **Upload** button.

Figure 4-103 Upload Ladder Logic Files - Upload

Communications Manager will display the uploading progress.



Figure 4-104 Upload Ladder Logic Files – Uploading in Progress

Communications Manager will display a message that the upload was successful.



Figure 4-105 Upload Ladder Logic Files – Files Uploaded Successfully

- **Remove Ladder Logic**



CAUTION

REMOVING LADDER LOGIC FILES WILL AFFECT PERIPHERAL EQUIPMENT USING LADDER LOGIC. ENSURE LADDER LOGIC IS NOT REQUIRED BEFORE DELETING FILES.

To remove an existing Ladder Logic file click on the ***Remove Ladder Logic*** button. Communications Manager will remove the previously installed Ladder Logic file.

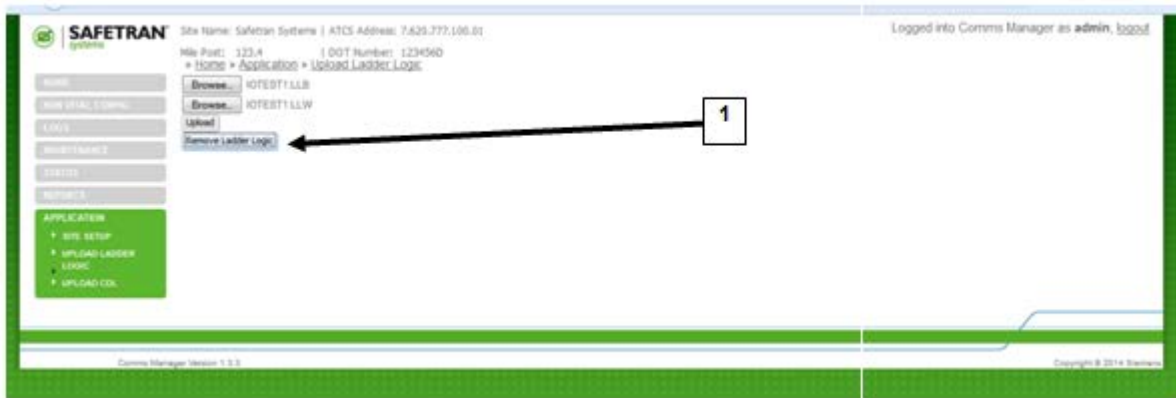

1 Click on the ***Remove Ladder Logic*** button.

Figure 4-106 Remove Ladder Logic Files

Communications Manager will confirm the removal of the Ladder Logic files and listed the file names that were deleted. At this point the Ladder Logic engine will not be running.

```

» Home » Application » Upload Ladder Logic
Browse... IOTEST1.LLB
Browse... IOTEST1.LLW
Upload
Remove Ladder Logic
iostat1.llb file deleted
iostat1.llw file deleted
All ladder logic files have been deleted successfully.The ladderlogic engine is not running.
    
```

Figure 4-107 Ladder Logic Files Removed

- **Upload CDL**

The **Upload CDL** selection uploads a CDL application file into the Communications Manager.

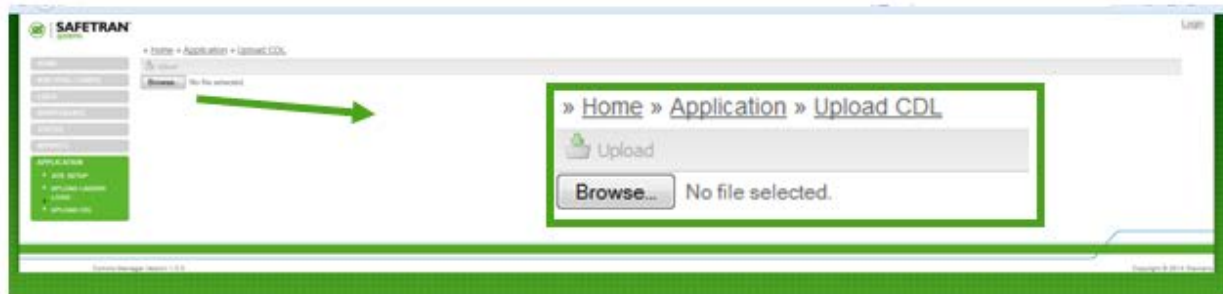

Figure 4-108 Upload CDL Application File

The following procedure details uploading the CDL into Communications Manager:

Click on Application from WebUI's main menu. Select '**Upload CDL**'. Observe the following window.

Select '**Browse**' and select file from list of CDL files.

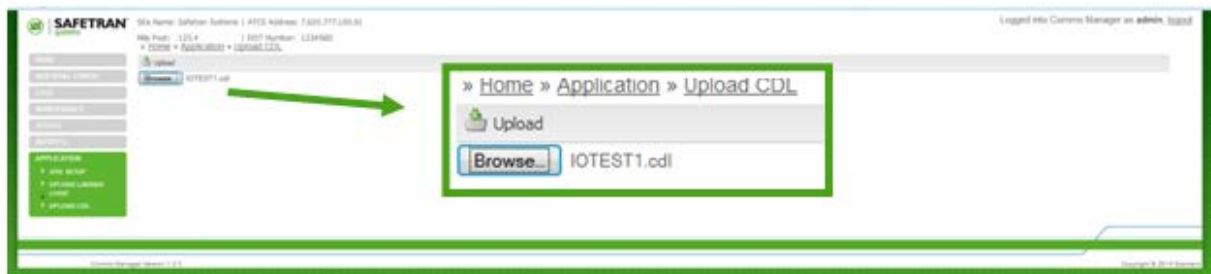

Figure 4-109 Browse CDL List

Click on '**Upload**'.

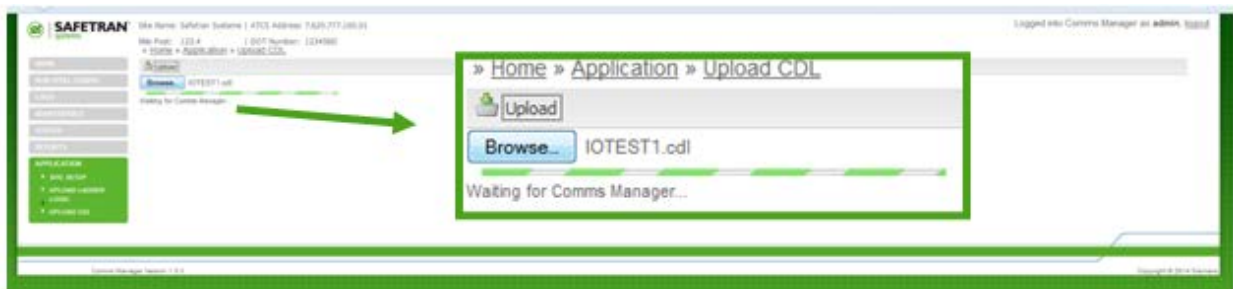

Figure 4-110: Upload CDL File

When uploading is finished observe the following window and click on '**Click here to run site setup**'

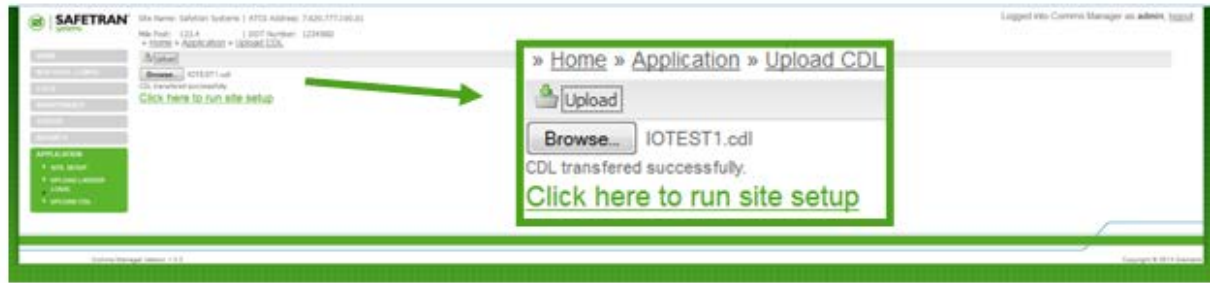

Figure 4-111 Run Site Setup

Click on '**Start**'

» [Home](#) » [Application](#) » [Site Setup](#)



Click on '**Finish**'.

» [Home](#) » [Application](#) » [Site Setup](#)



The CDL file will be saved to ECD's flash memory
Observe the following status window will appear in lower right corner.

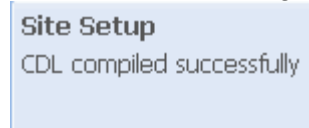

4.3.9 Web UI Logout

To logout of a Web UI session, click on the **logout** interactive text in the upper right corner of the page as shown in the figure below.

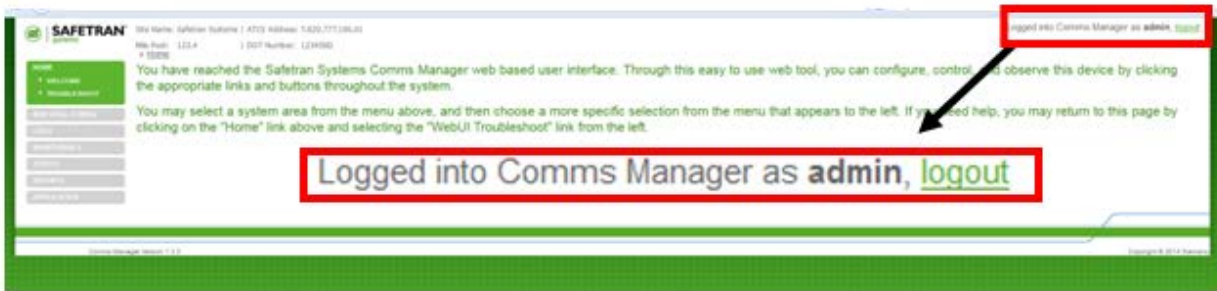

Figure 4-112 Web UI Logout

A window will appear verifying the logout procedure is complete, as shown in the figure below.



Figure 4-113 Web UI Logout Confirmation

This Page Intentionally Left Blank

SECTION 5 LOCAL USER INTERFACE

5.0 LOCALUSER INTERFACE

The Communications Manager comes equipped with a 2X20 Alphanumeric Vacuum Fluorescent Display (VFD) and a 5 x 5 matrix keypad for configuration, option selections, and data entry.



Figure 5-1 Local User Interface Display and Keypad

5.1 LOCAL USER INTERFACE KEYPAD

The Local User Interface keypad is provided for local navigation through the Communications Manager Menus and data entry. The Keypad Key functions are detailed in Figure 5-2.

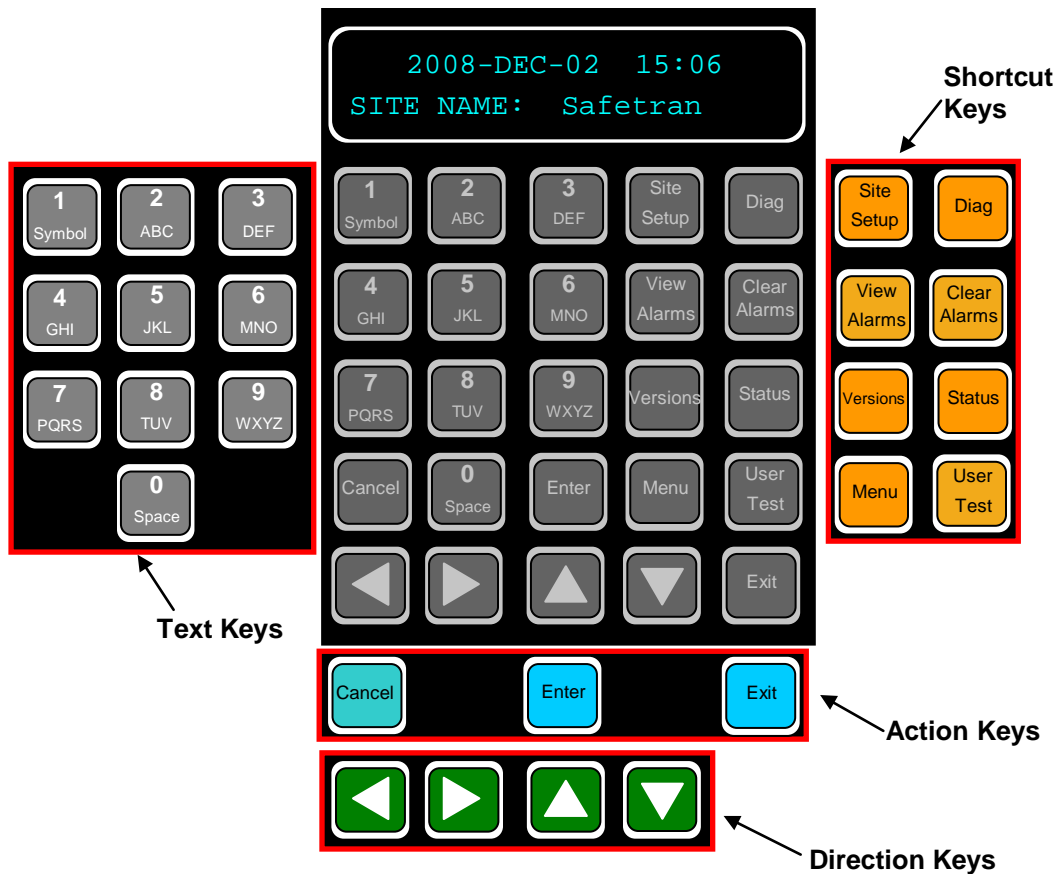

- **TEXT KEYS** – These keys operate in the same manner as a Cell Phone Keypad. Letters and numbers cycle as the key is pressed.
- **SHORTCUT KEYS** – These keys are shortcuts to specific menus.
- **ACTION KEYS** – These keys Enter, Exit, or Cancel an entry.
- **DIRECTION KEYS** – These keys move through the menus horizontally and vertically. Pressing an action key enters or exits the entry or menu.

Figure 5-2 Local User Interface Keypad Functions

5.2 LOCAL USER INTERFACE MENUS

The Local User Interface provides access to all of the Communications Manager menus from the front panel. Set up and configuration functions can be performed locally without the need of a computer or other external interface.

5.2.1 Shortcut Keys

Shortcut keys provide direct access to key menus. The following details the available shortcut keys and their respective function.

- **MENU** – Opens the Main Menu which contains all sub menus. Press Menu from any sub menu to return to the Main Menu starting point.
- **SITE SETUP** – Open Site Setup Menu.
- **DIAG** – Open the Diagnostic Log.
- **VIEW ALARMS** – Open the Alarm Log. (Future Use)
- **CLEAR ALARMS** – Resets alarms in all applications.
- **VERSIONS** – Opens the Display Version Menu which details the current versions of
 - Software Version, Build Date, and ID number
 - CDL Name and Version
 - Ladder Logic Name, Revision, ID number, and Checksum
 - Linux Kernel Version
 - FPGA Version
 - CPLD Version
 - Top Assembly Part Number, Serial Number, and Revision
 - Carrier Part Number, Serial Number, and Revision
- **STATUS** – Opens Status display menu for:
 - Digital Inputs
 - Analog Inputs
 - Relay Outputs
 - GPS Info

- **USER TEST** – Trigger CDL function if programmed.

5.2.2 Test Keys

These keys function in the same manner as most cell phone keypads. Entering text for Site Info or naming inputs and outputs can be performed using the text keys. Each key steps through the letters and numbers associated to that key.

5.2.3 Direction Keys

The Action keys provide the following functions:

- **CANCEL** – Cancels the entry, exits all menus, and returns to the Home Information display screen.
- **ENTER** – Enters the Menu or Data Entry information.
- **EXIT** – Exits to the top of the current menu. Repeat entry will cycle back up through the menu structure to the Home Information display.

5.3 MENU STRUCTURES

The following Menu Structure displays provide the path of each Menu and Sub-menu. Configuration, Function, and Data options are listed for each entry. Structure for the Main Menu will be detailed first, followed by details of the Menu using the Shortcut keys.

5.3.1 Menu

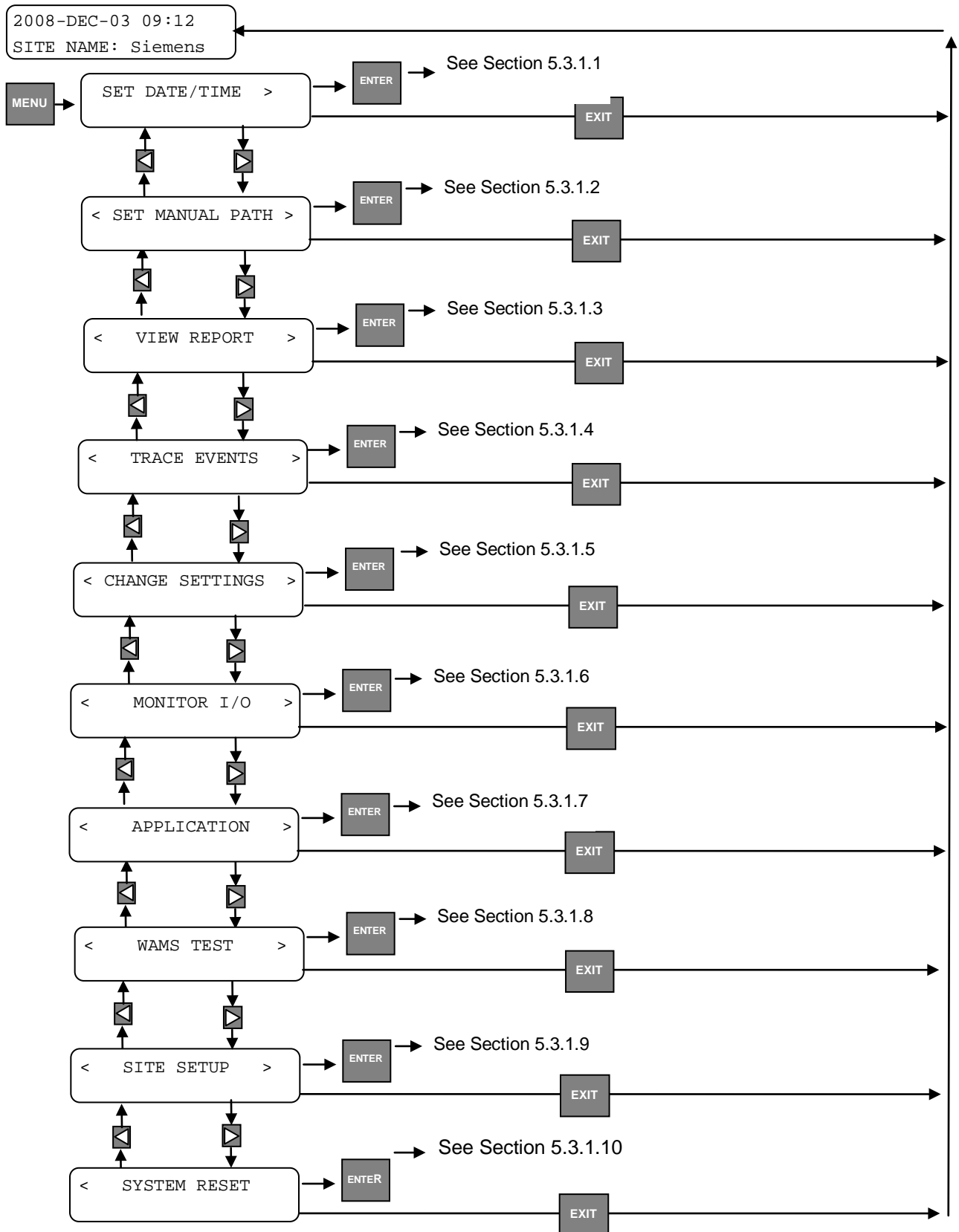

5.3.1.1 Set Date/Time

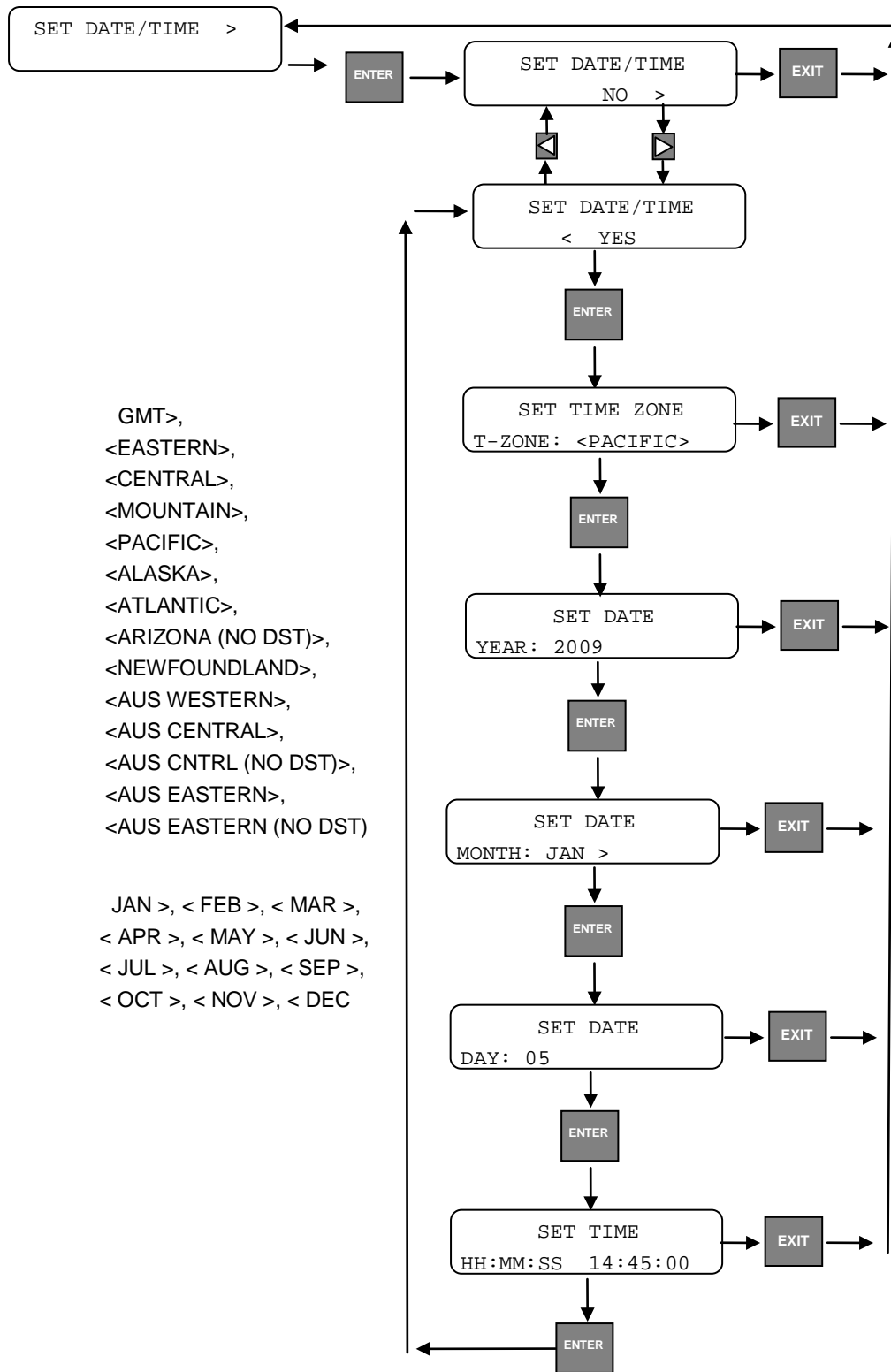

5.3.1.2 Set Manual Path

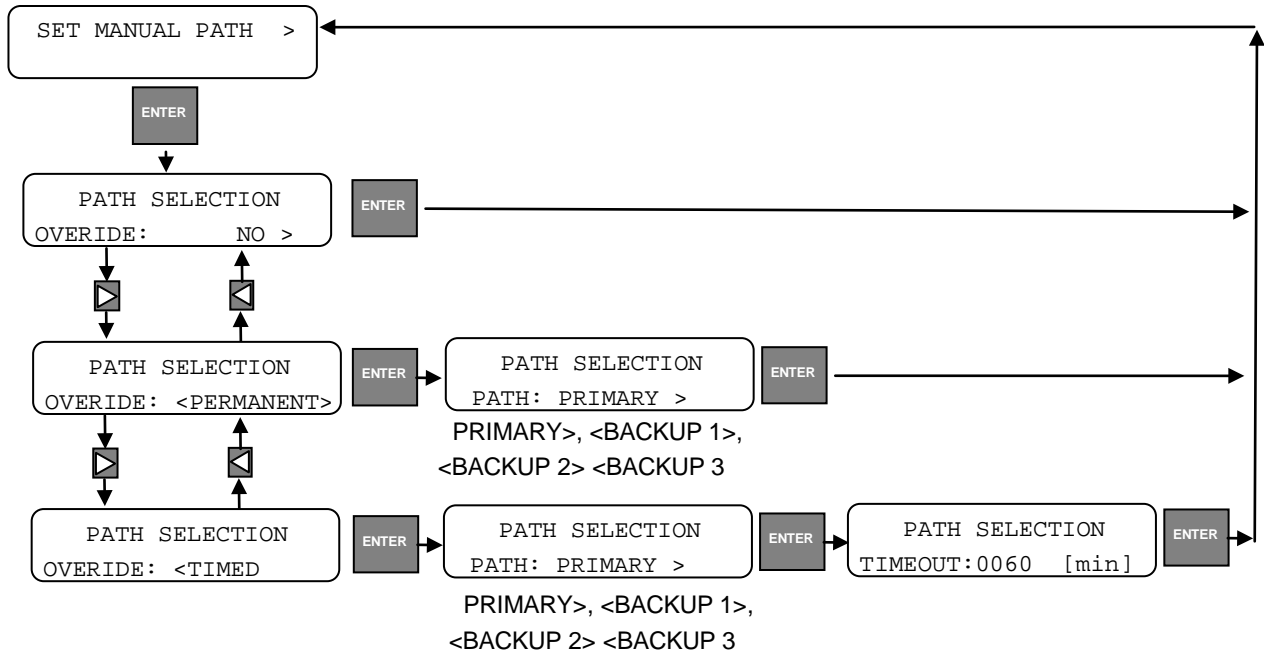

5.3.1.3 View Report

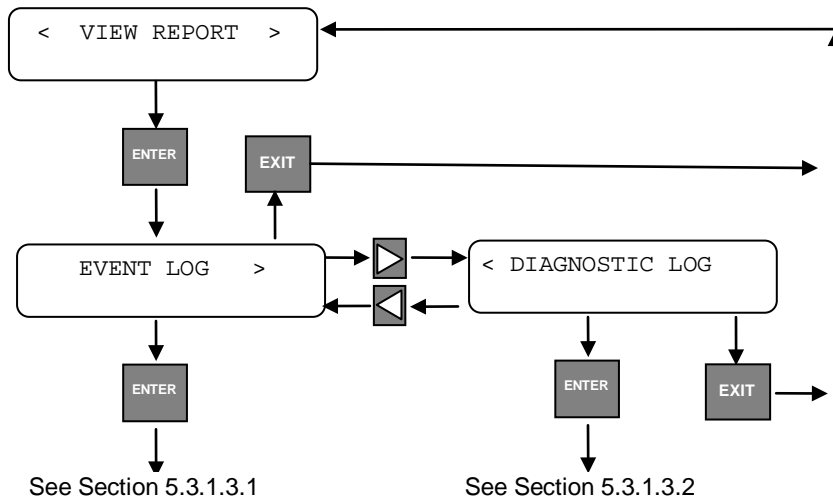

• **Event Log**

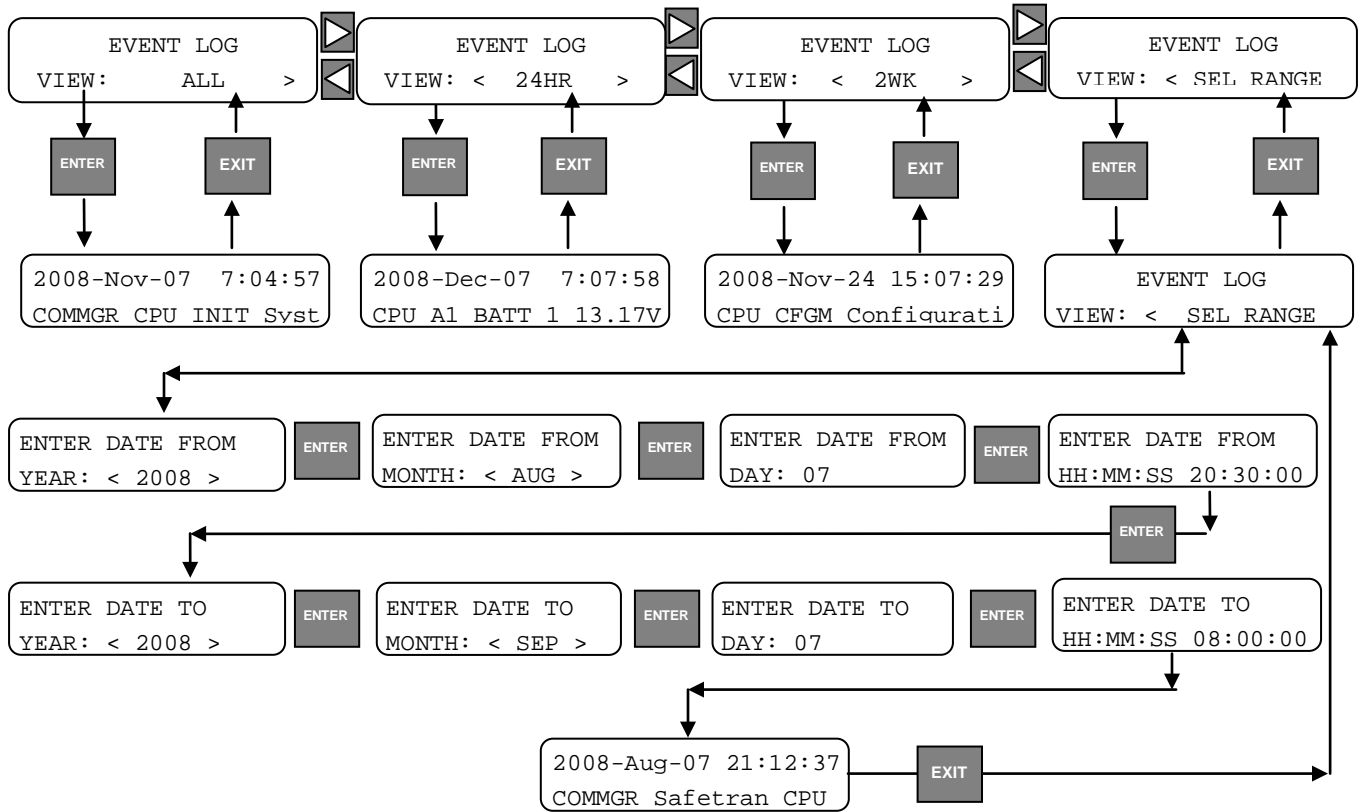

• Diagnostic Log

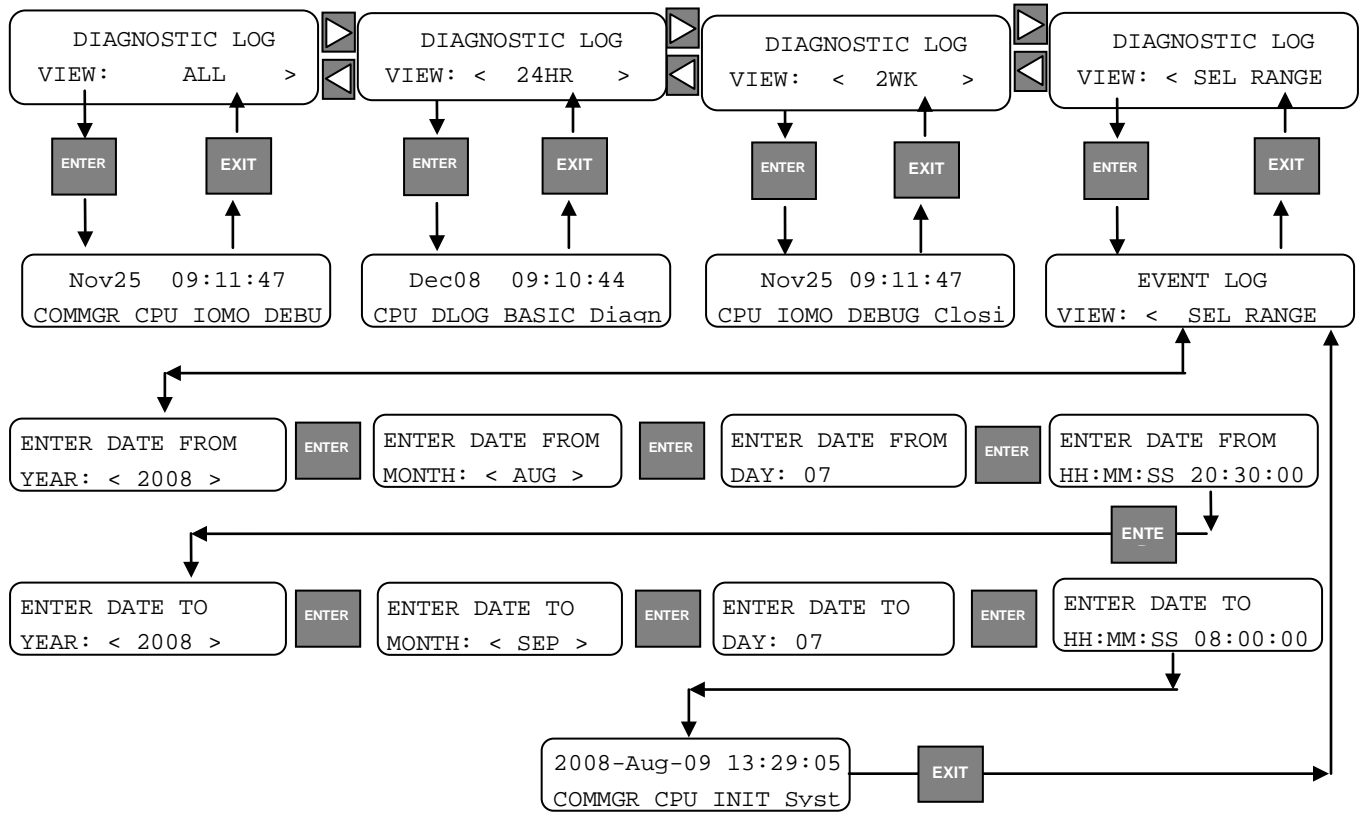

5.3.1.4 Trace Events

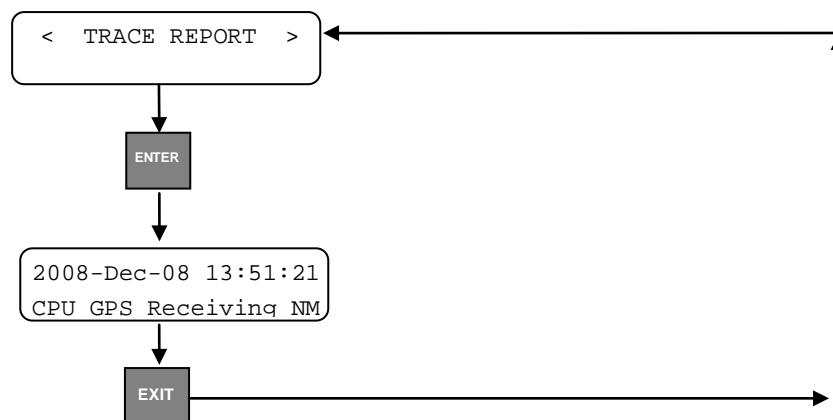

5.3.1.5 Change Settings

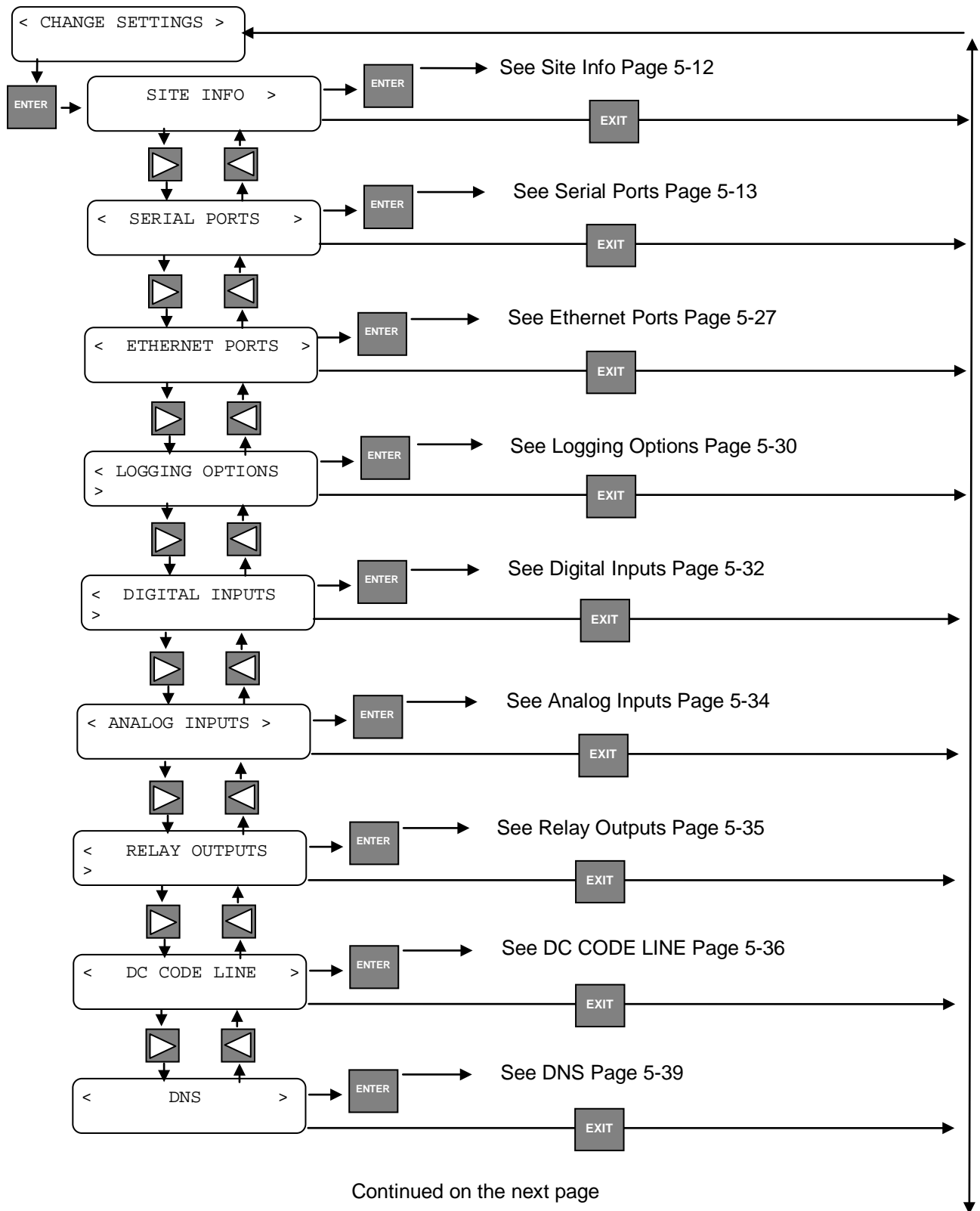

Continued from previous page

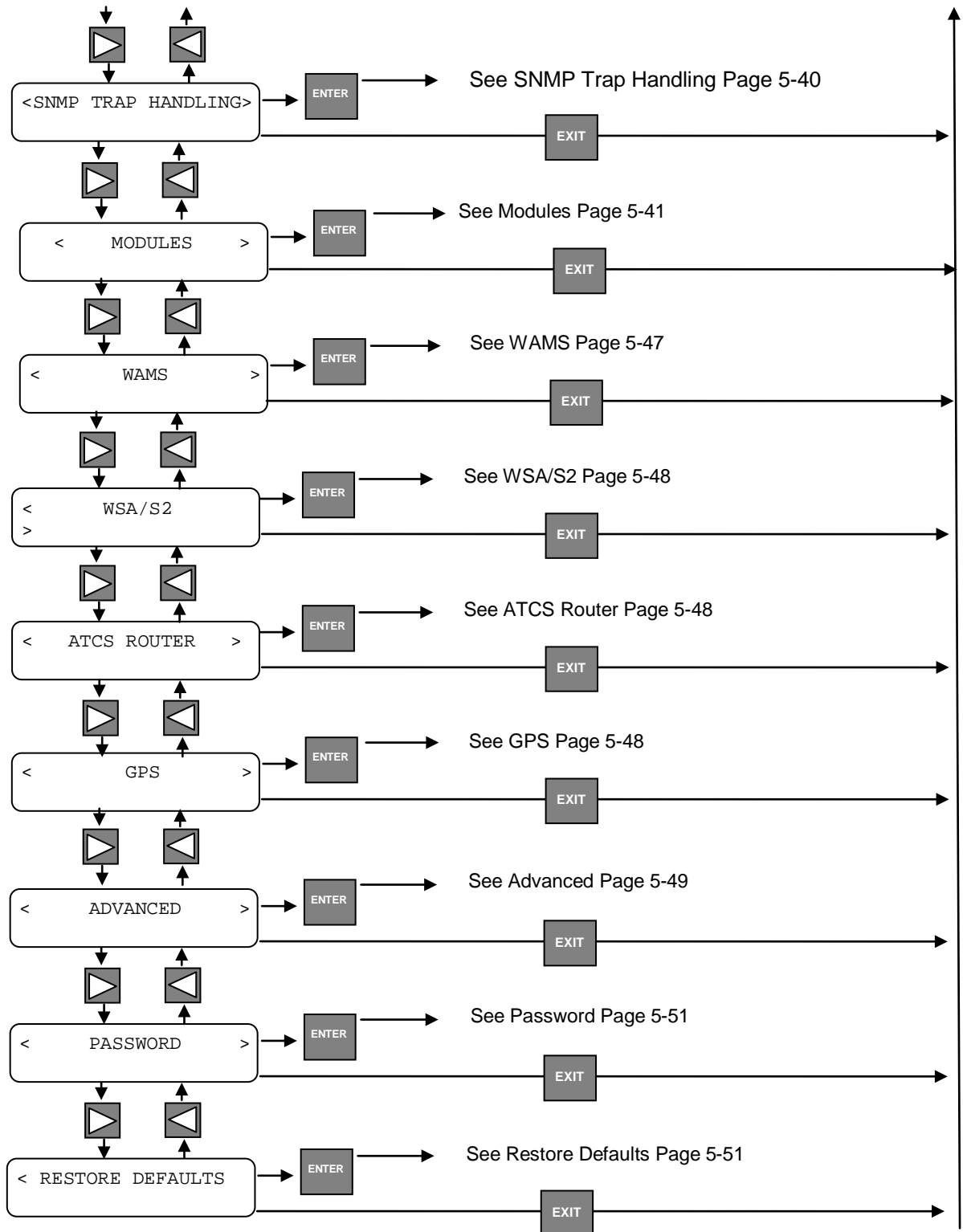

• Site Info

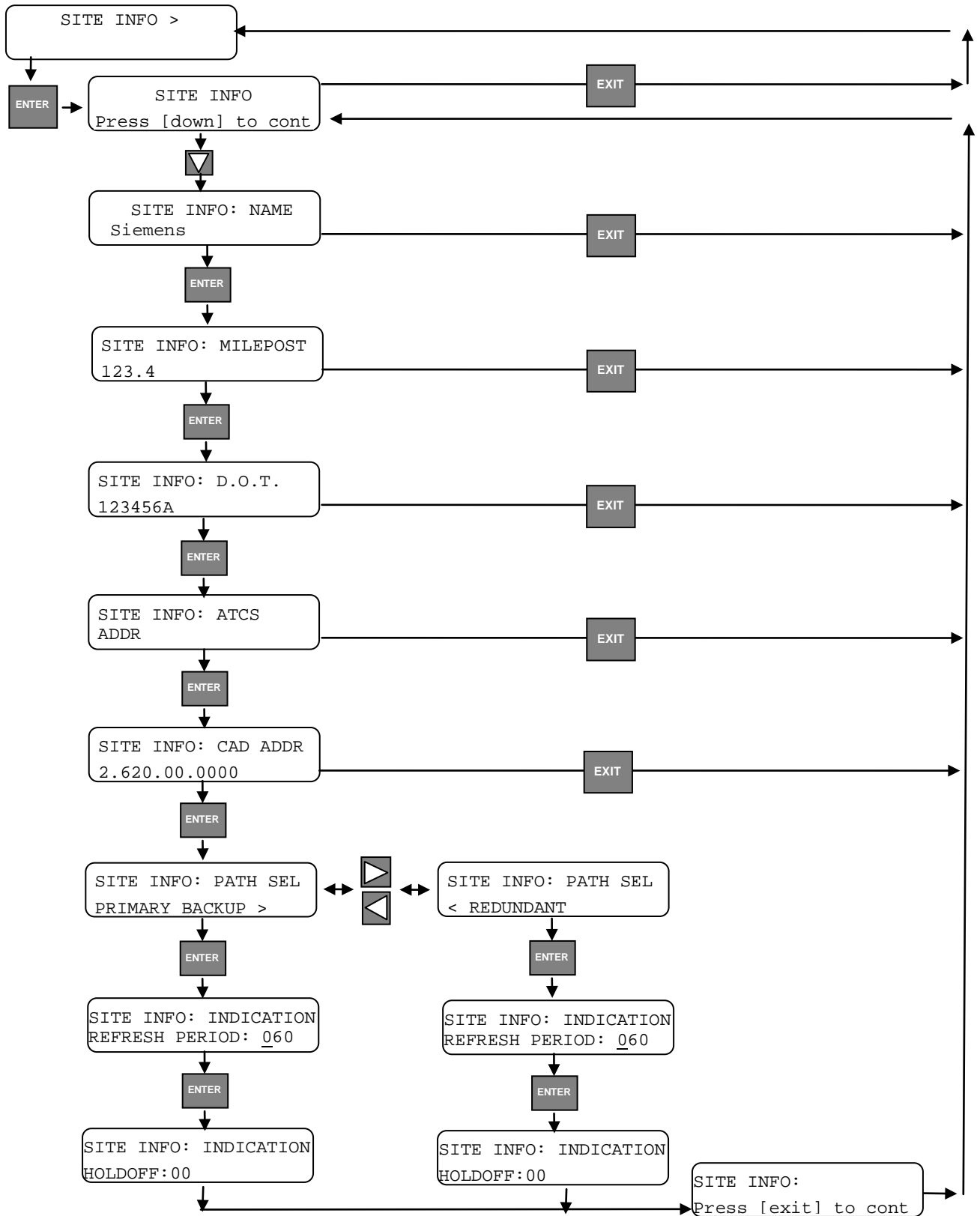

• **Serial Ports**

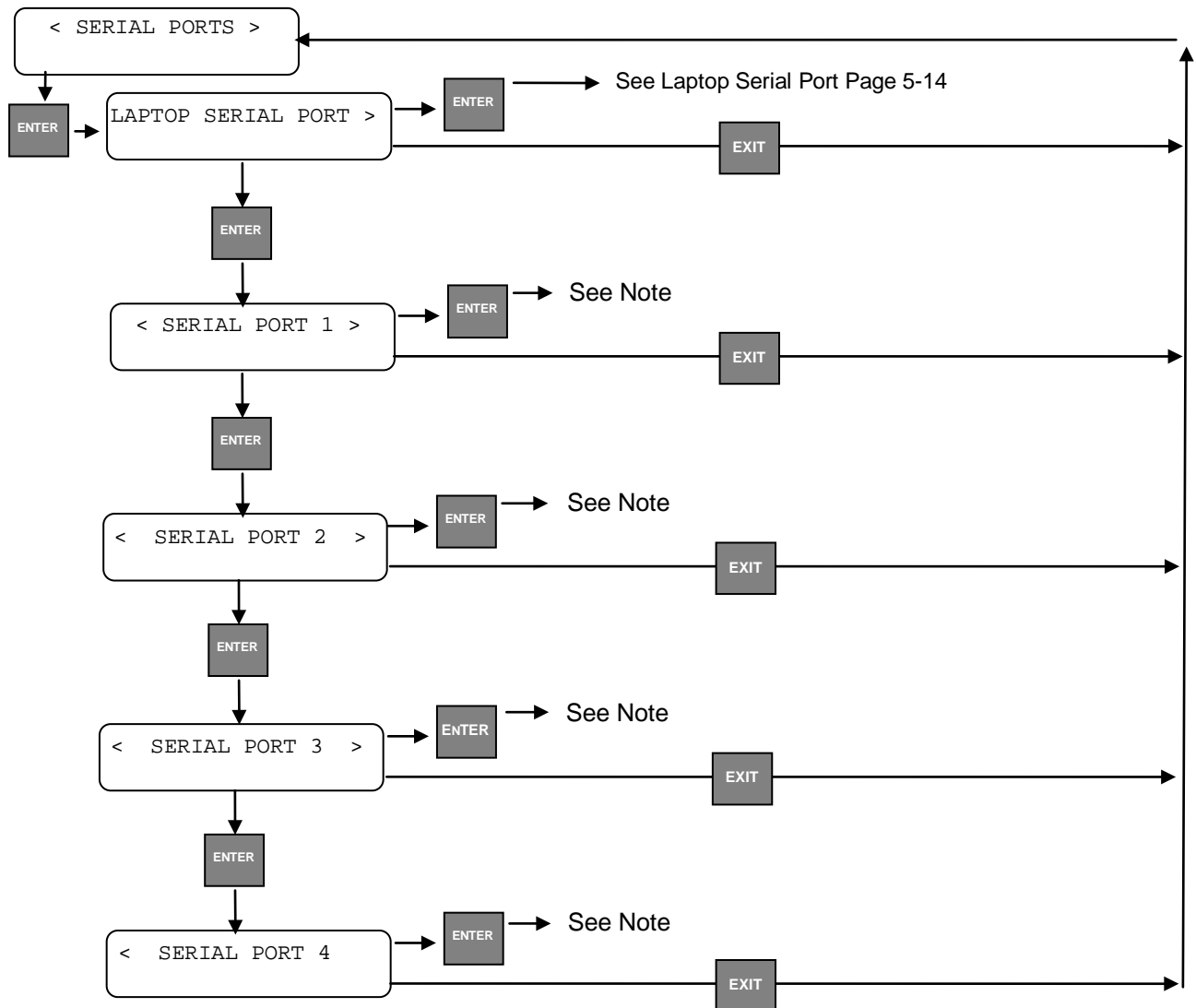

NOTE

NOTE
 Serial and Ethernet Ports can be configured using several paths and protocols. The following menus describe various options relative to each path and protocol combination.

• Laptop Serial Port

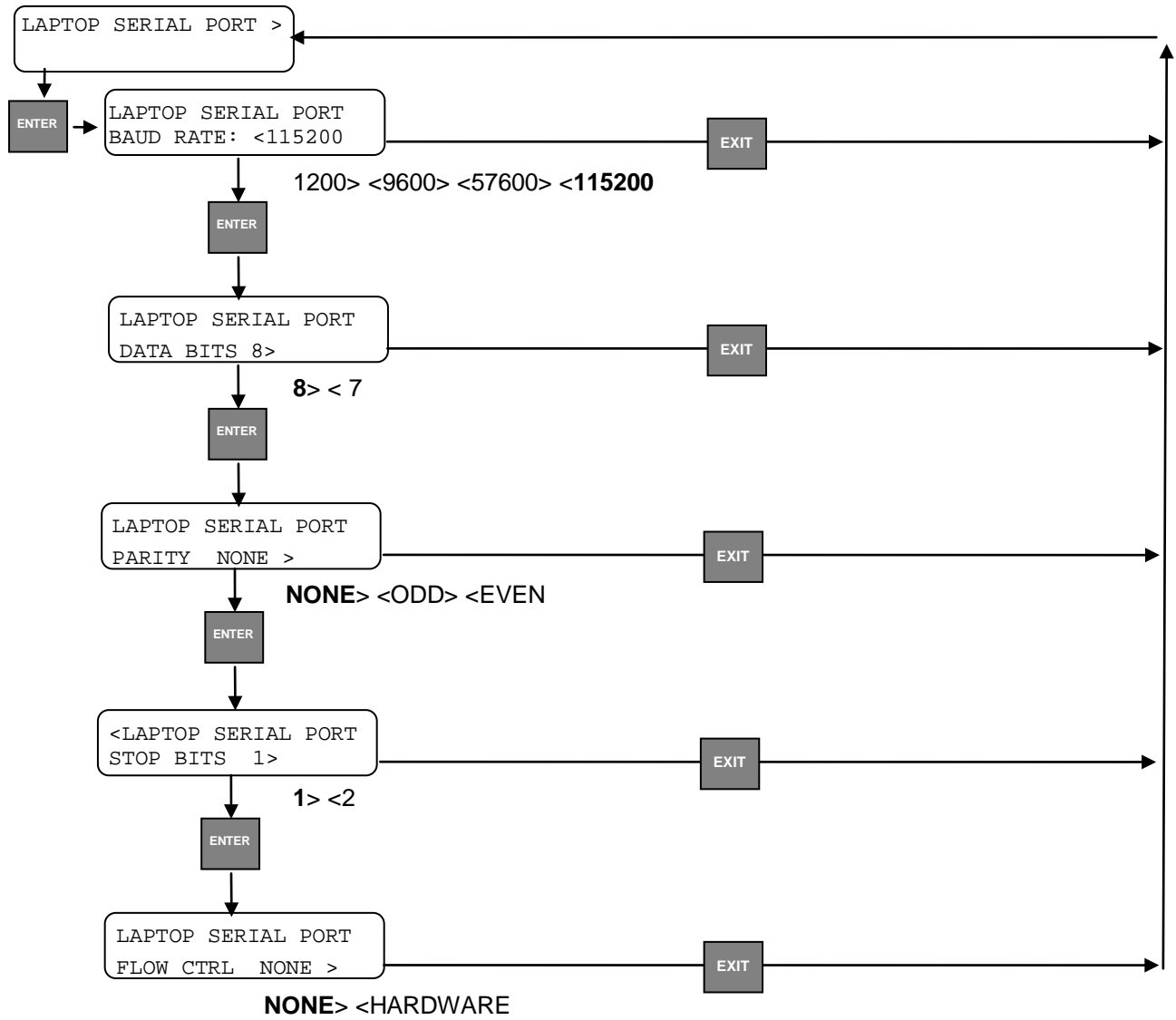

• **Serial Ports 1 – 4 (Path Type: NONE)**

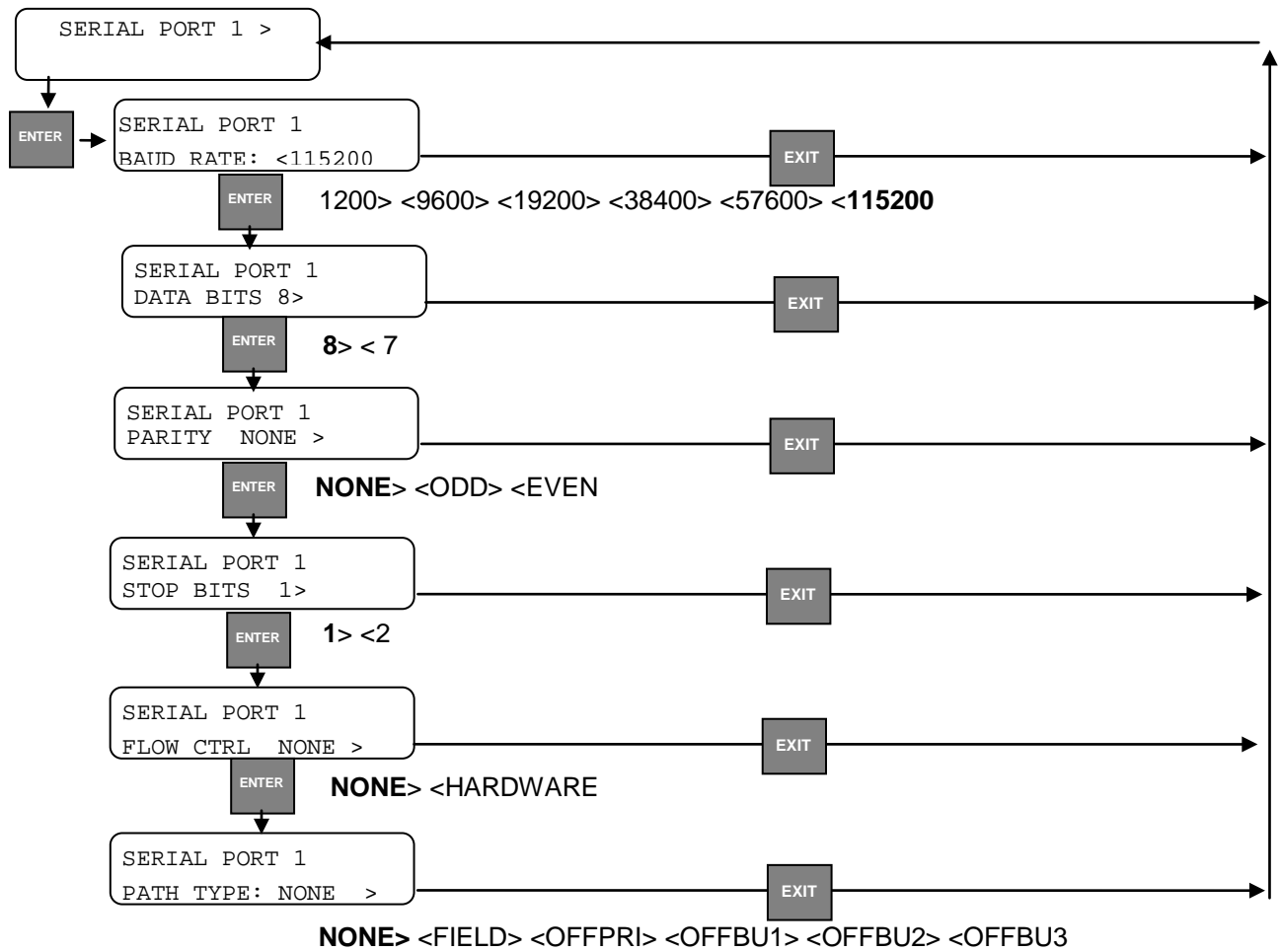

• **Serial Ports 1 – 4 (Path Type: FIELD)**

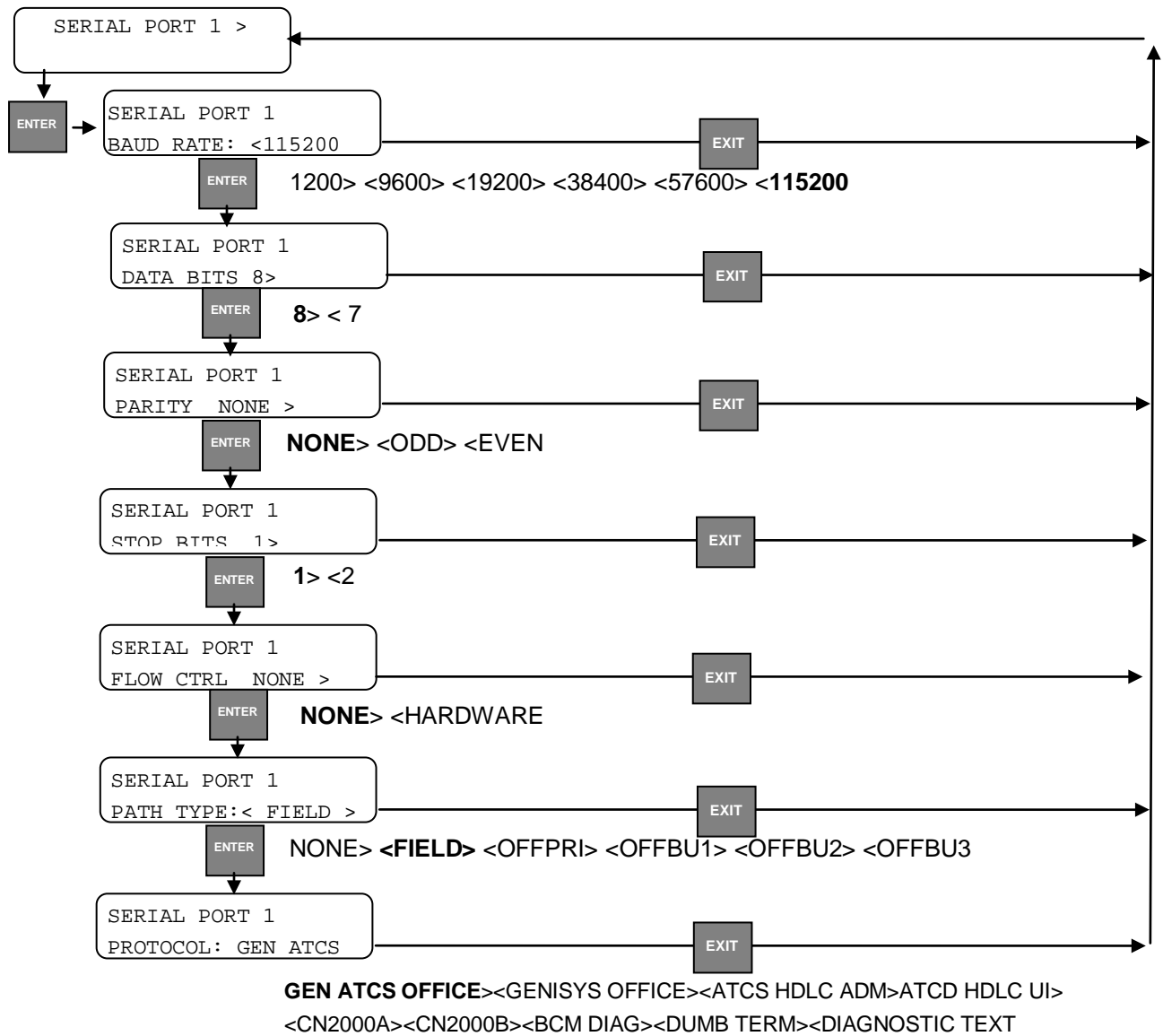

- Serial Ports 1 – 4 (Protocol: GEN ATCS OFFICE)

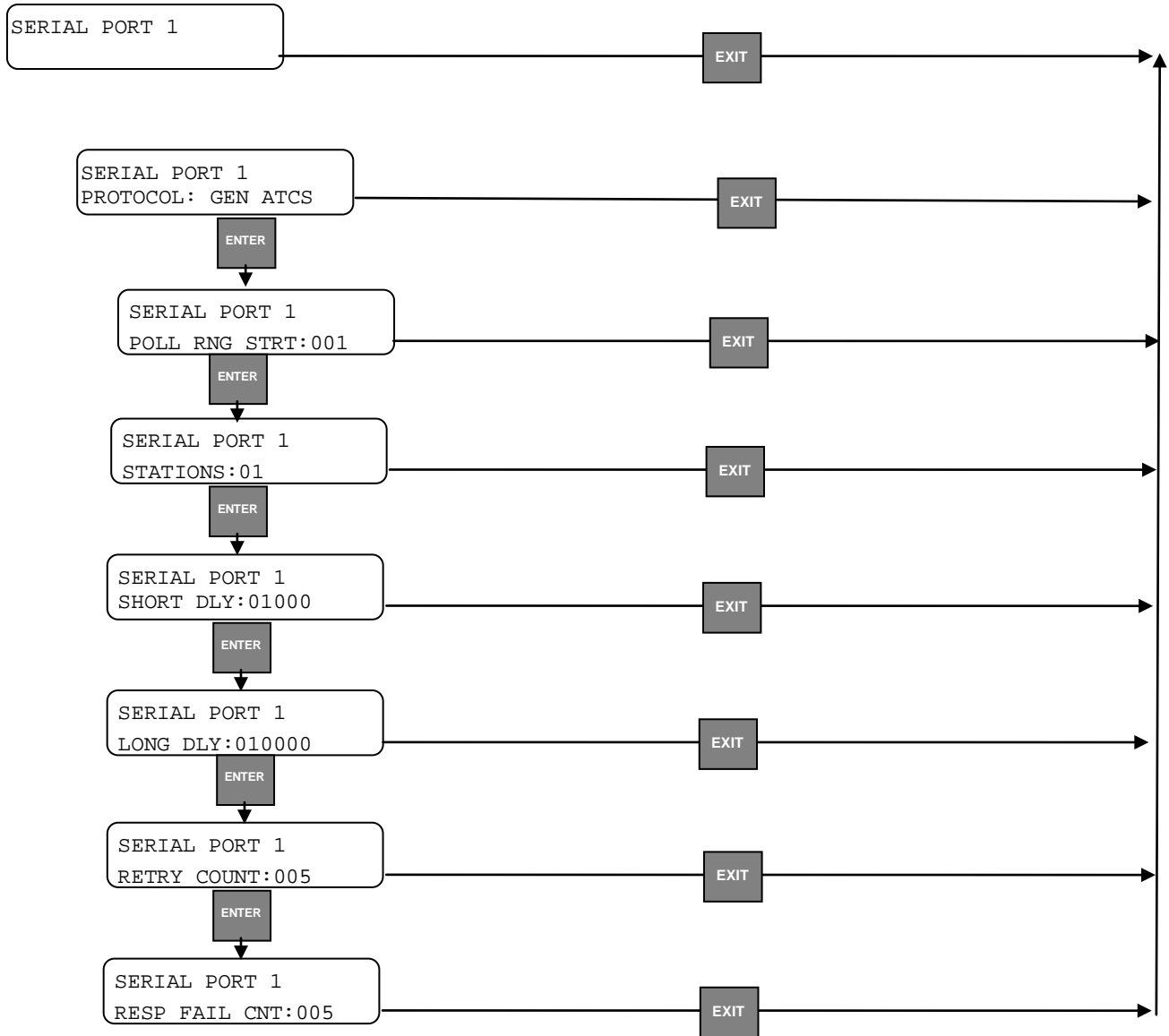

• **Serial Ports 1 – 4 (Protocol: GENISYS OFFICE)**

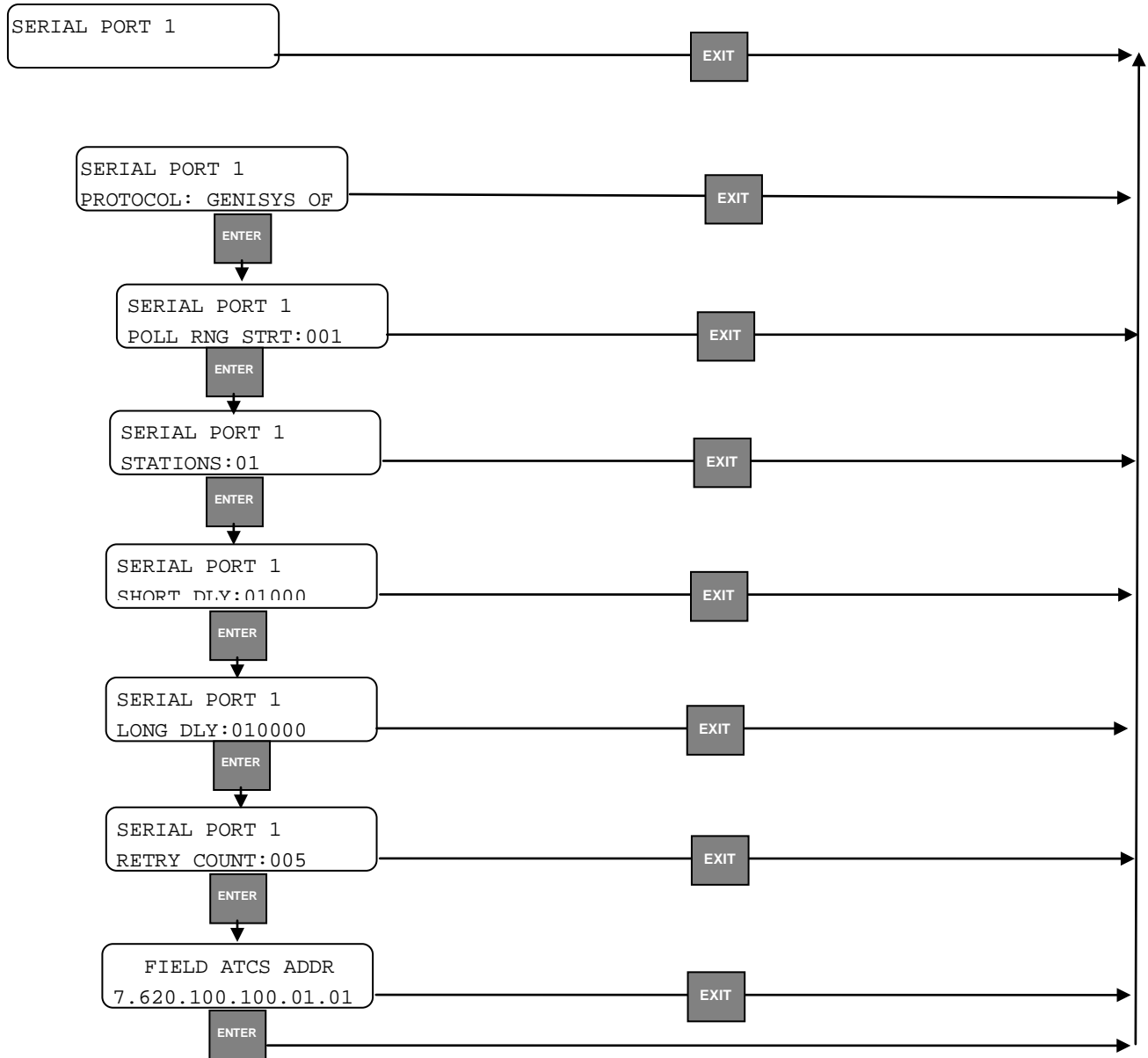

- Serial Ports 1 – 4 (Protocol: ATCS HDLC UI)

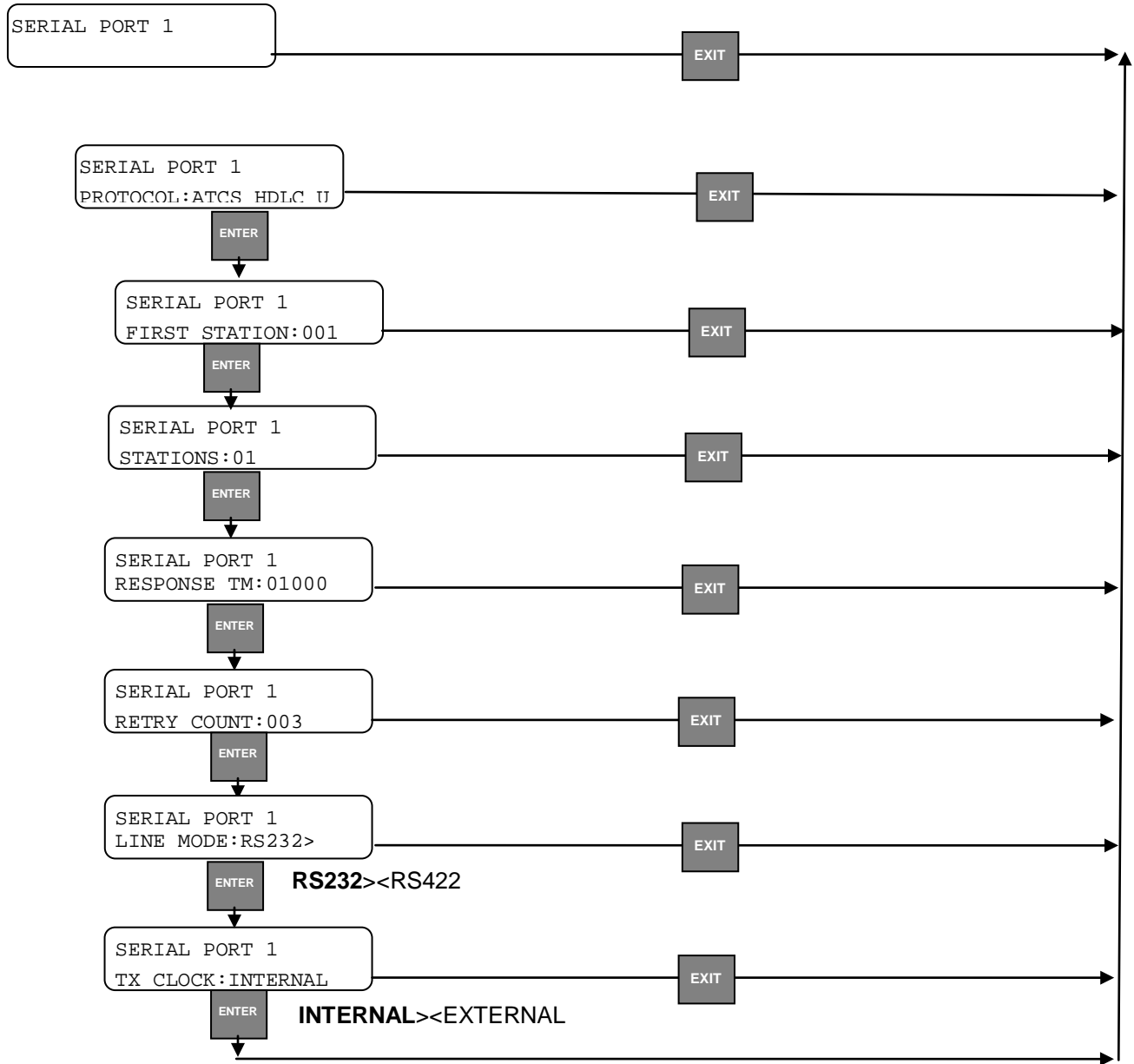

- Serial Ports 1 – 4 (Protocol: CN2000A & CN2000B)

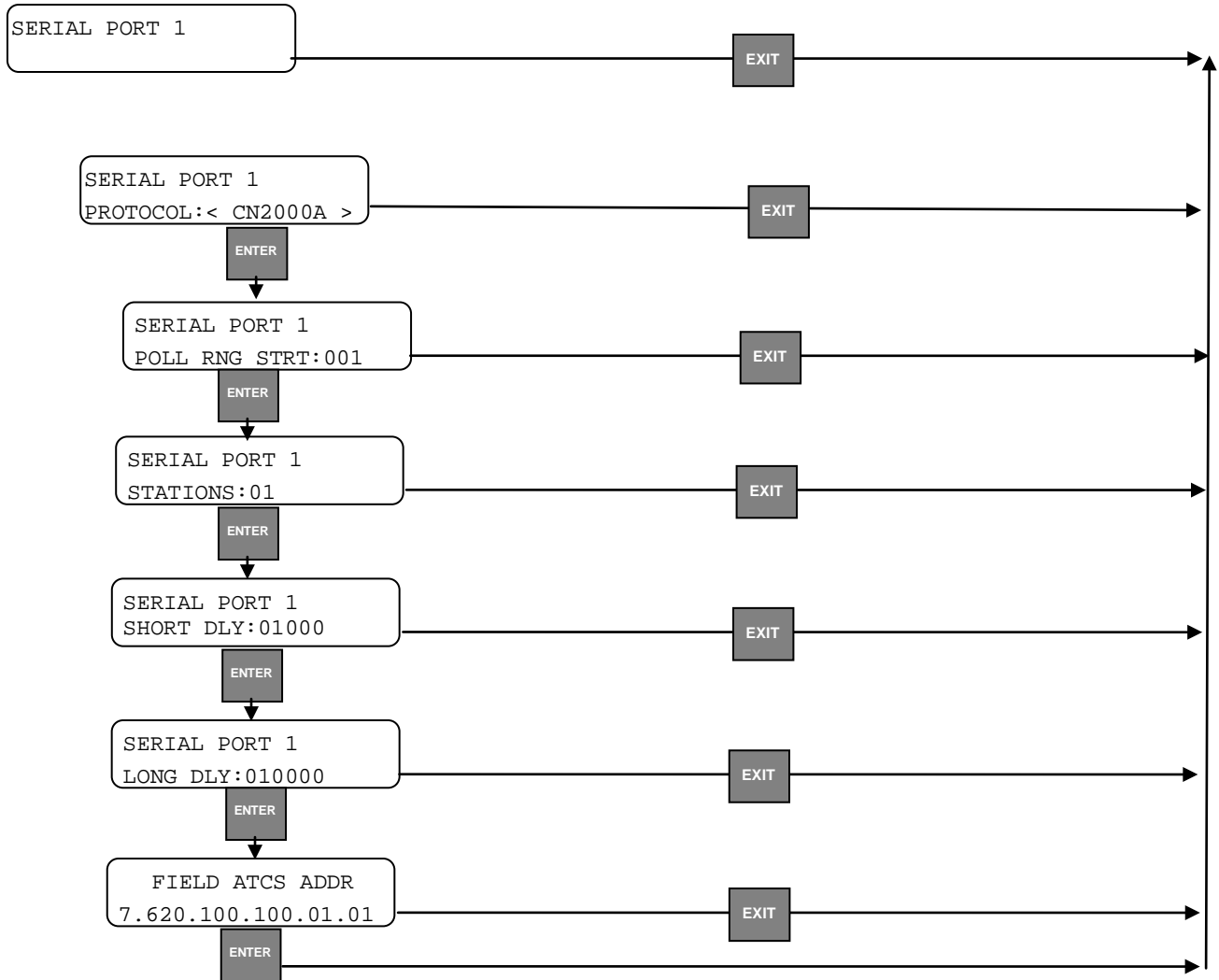

- **Serial Ports 1 – 4 (Protocol: BCM Diag)**

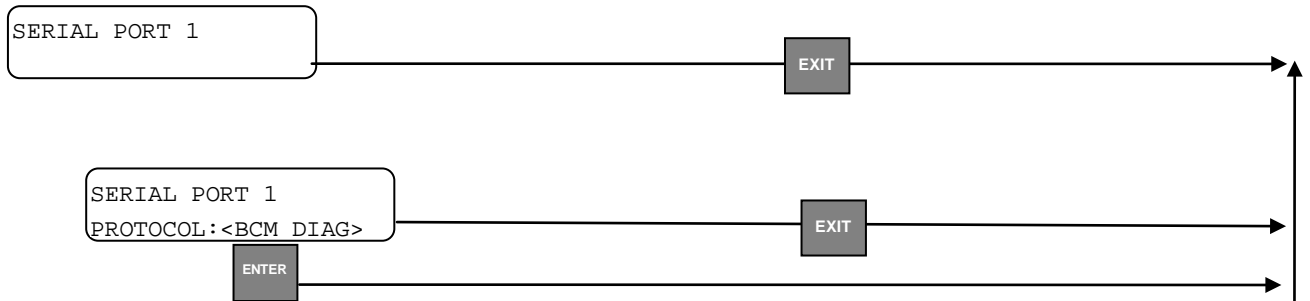

- **Serial Ports 1 – 4 (Protocol: Dumb Terminal & Diagnostic Text)**

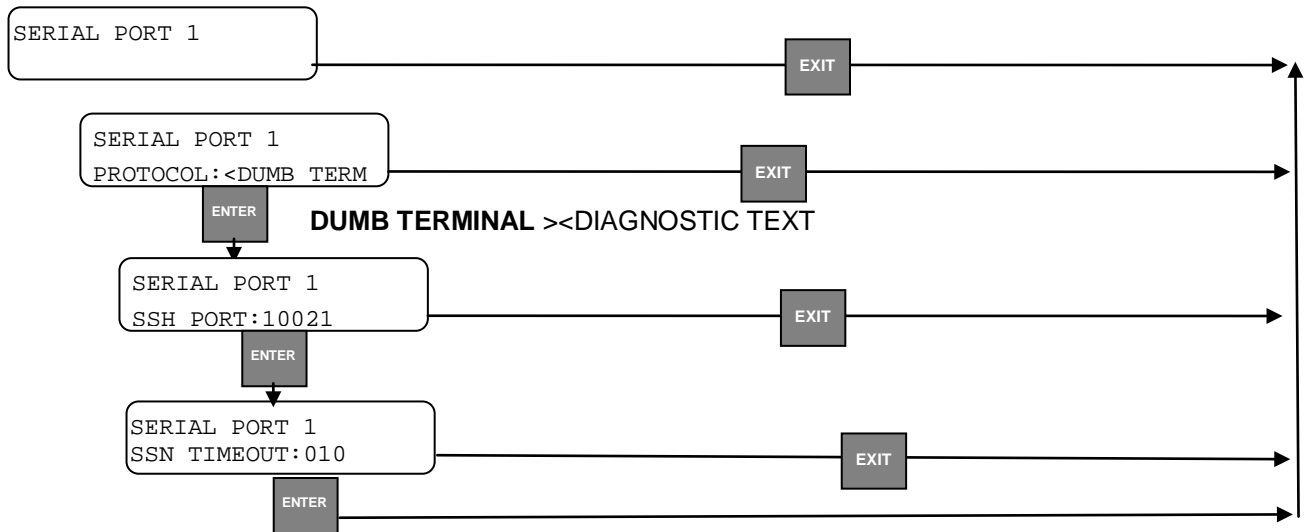

• **Serial Ports 1 – 4 (Path Type: Office Primary, Office Backup 1, 2, & 3)**

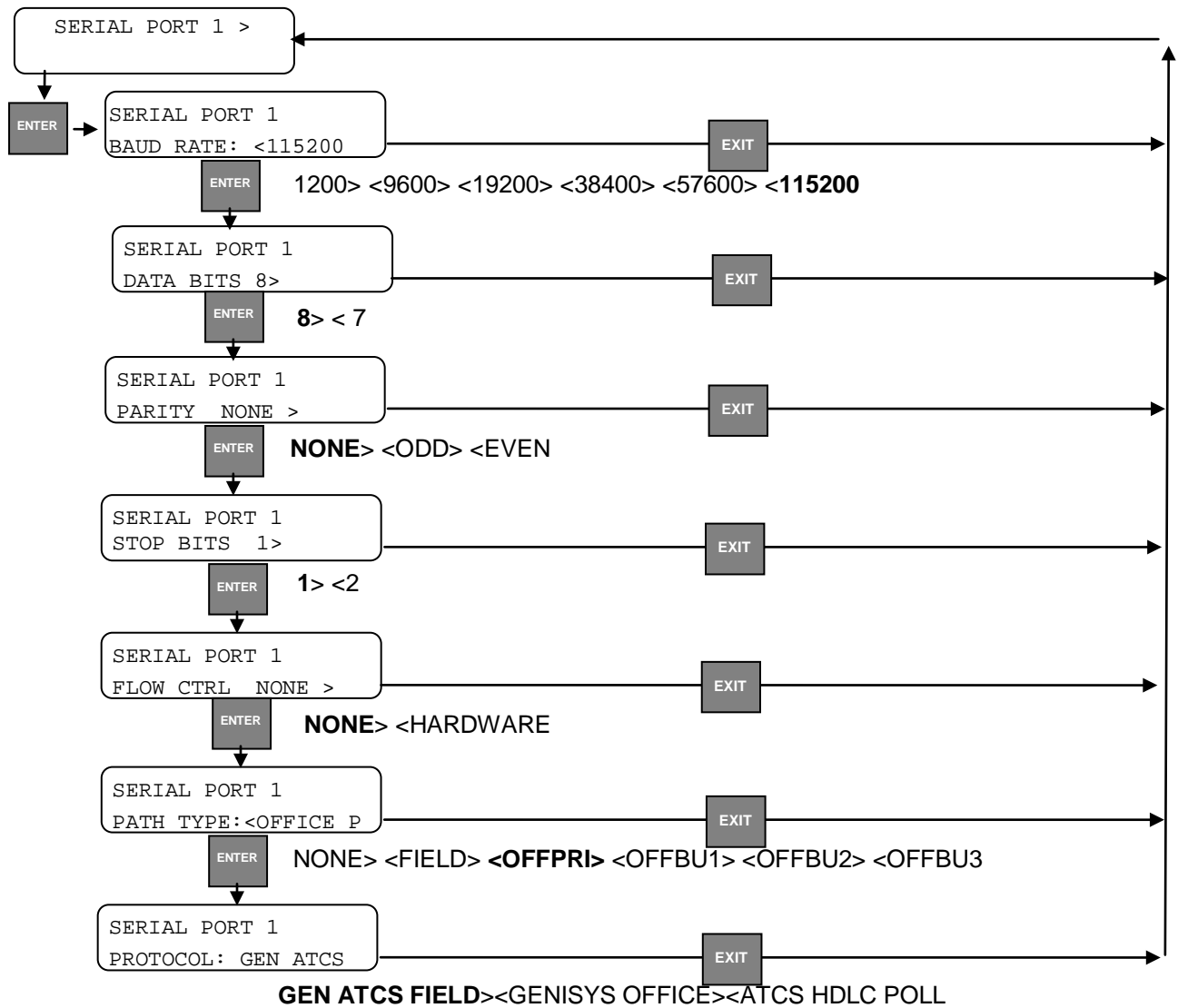

• **Serial Ports 1 – 4 (Protocol: GEN ATCS FIELD)**

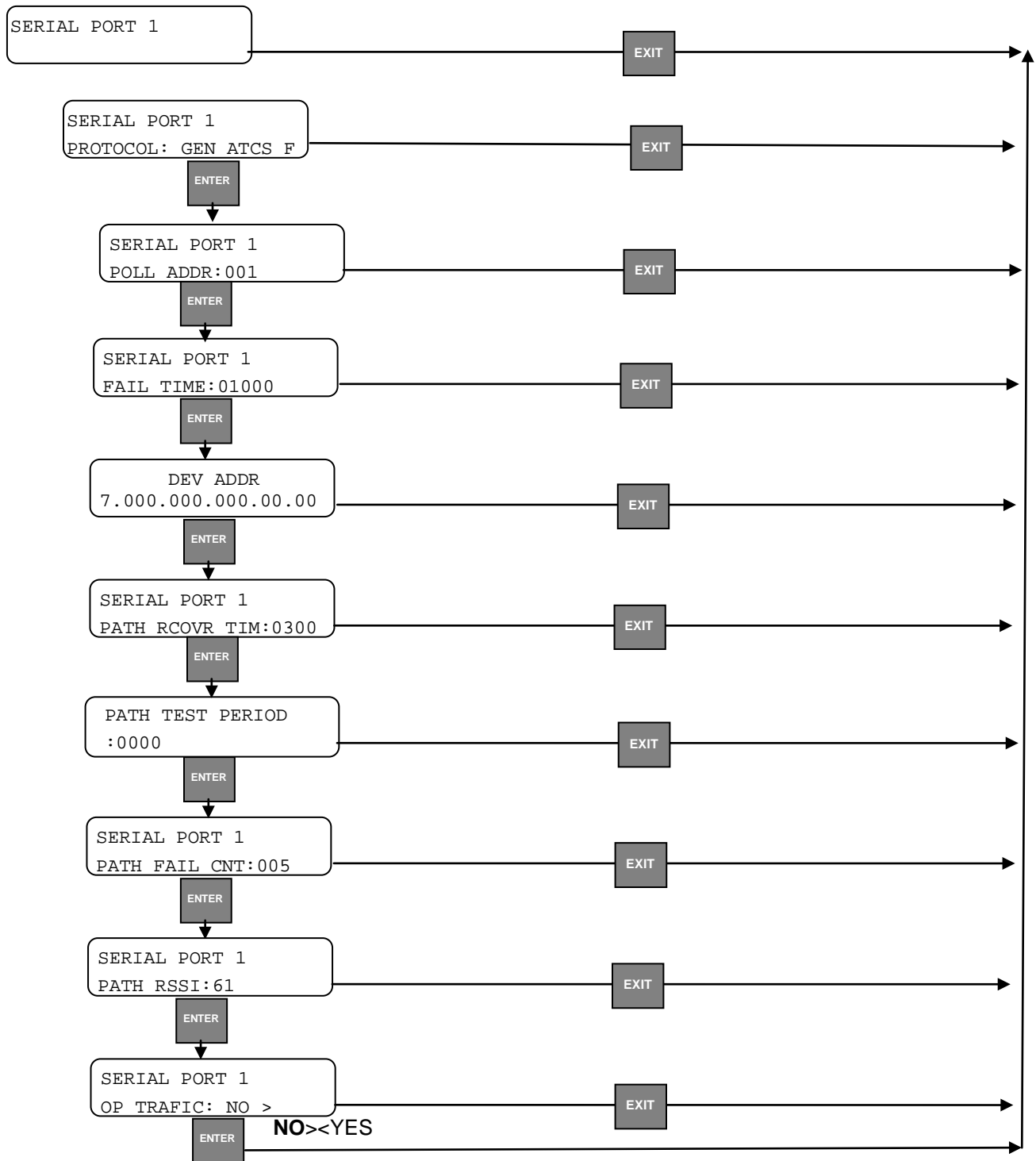

• **Serial Ports 1 – 4 (Protocol: GENISYS FIELD)**

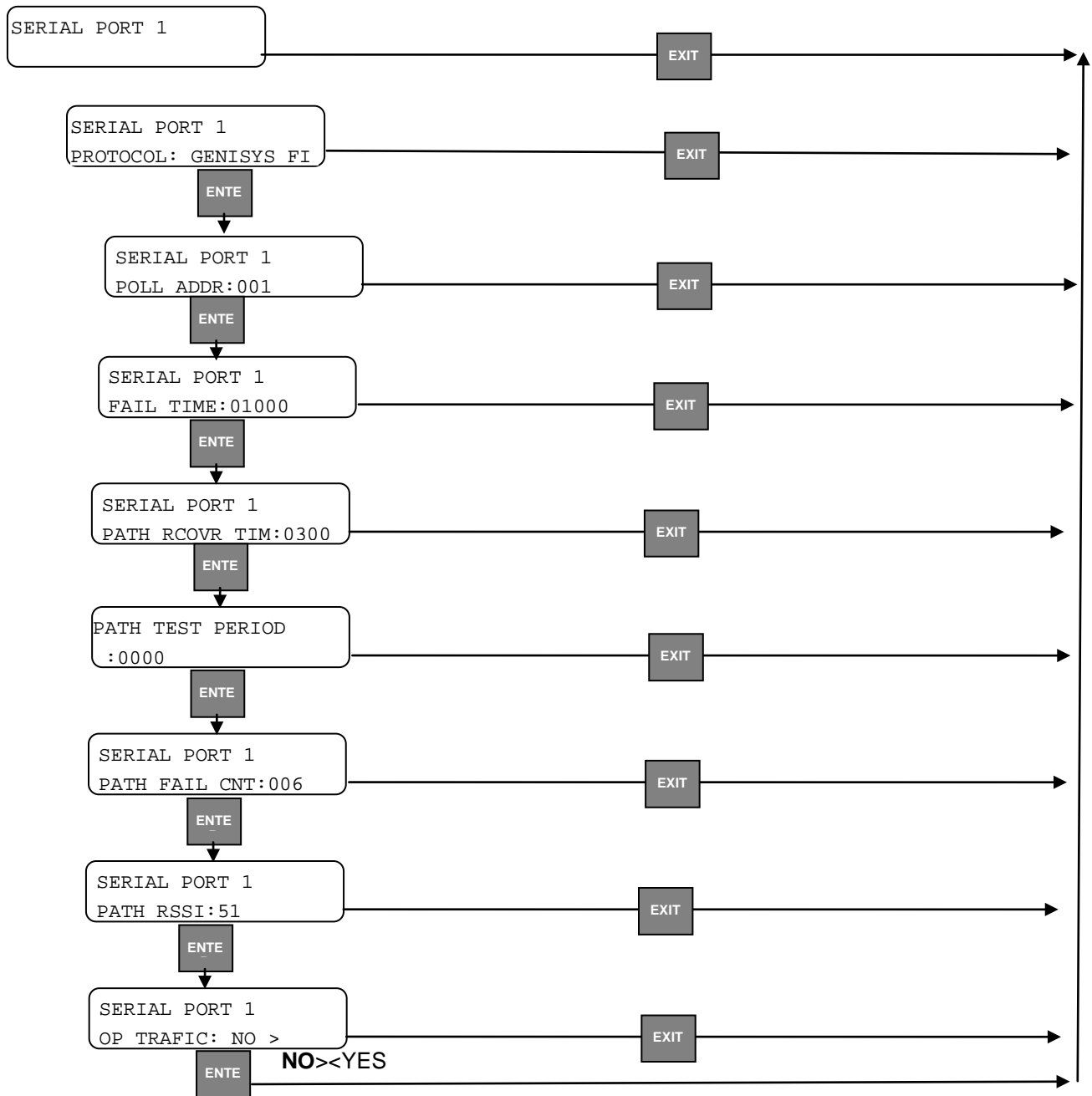

• **Serial Ports 1 – 4 (Protocol: ATCS HDLC)**

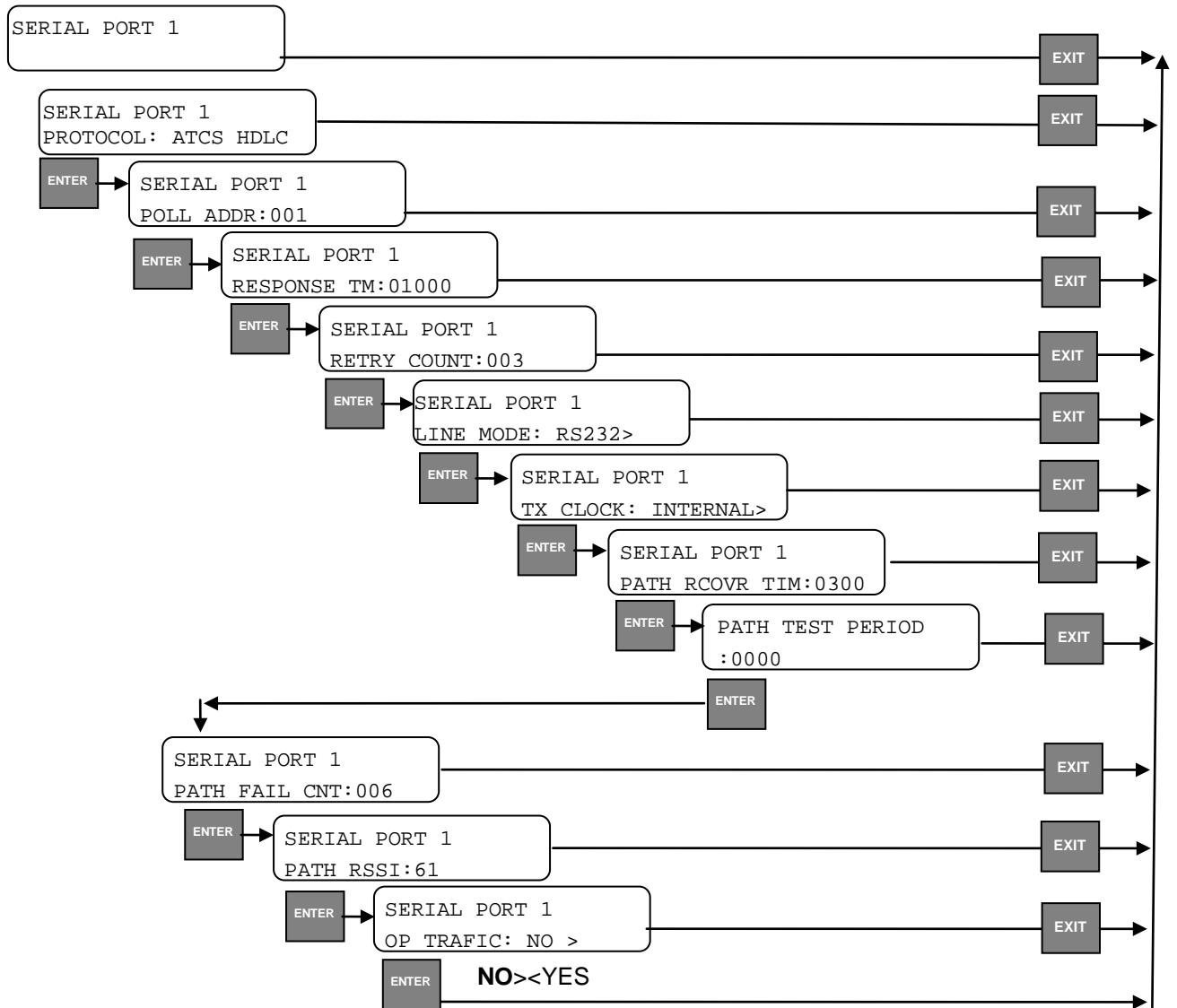

• Ethernet Ports

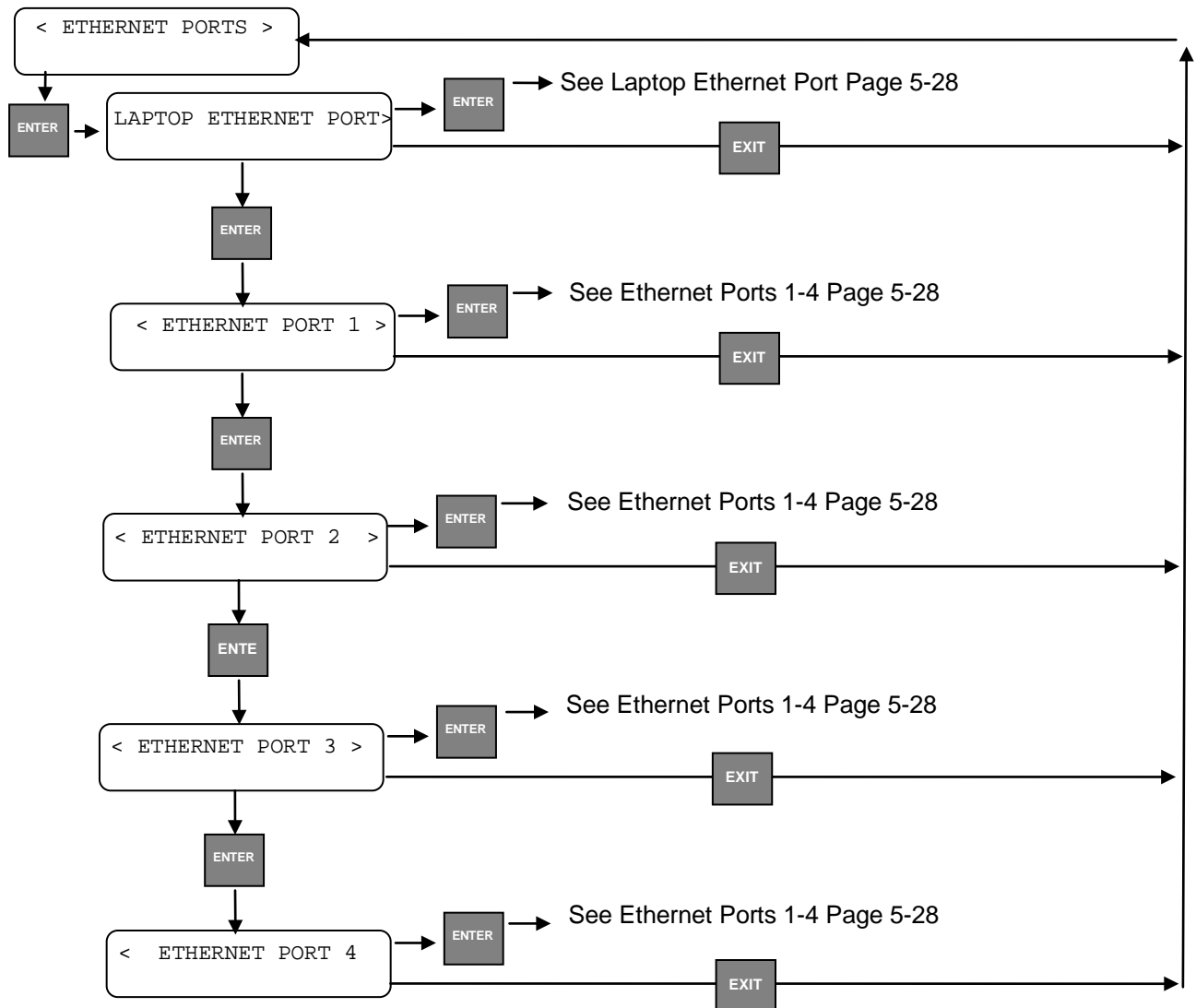

- Laptop Ethernet Port**

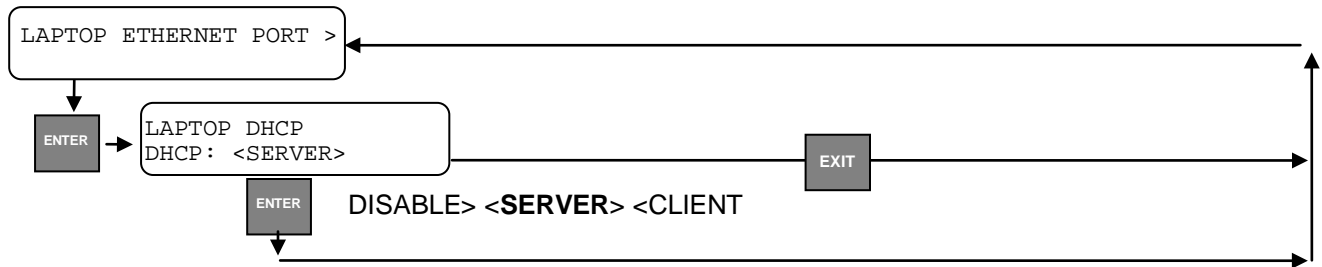

- Ethernet Ports 1 – 4 (DHCP Client Disable)**

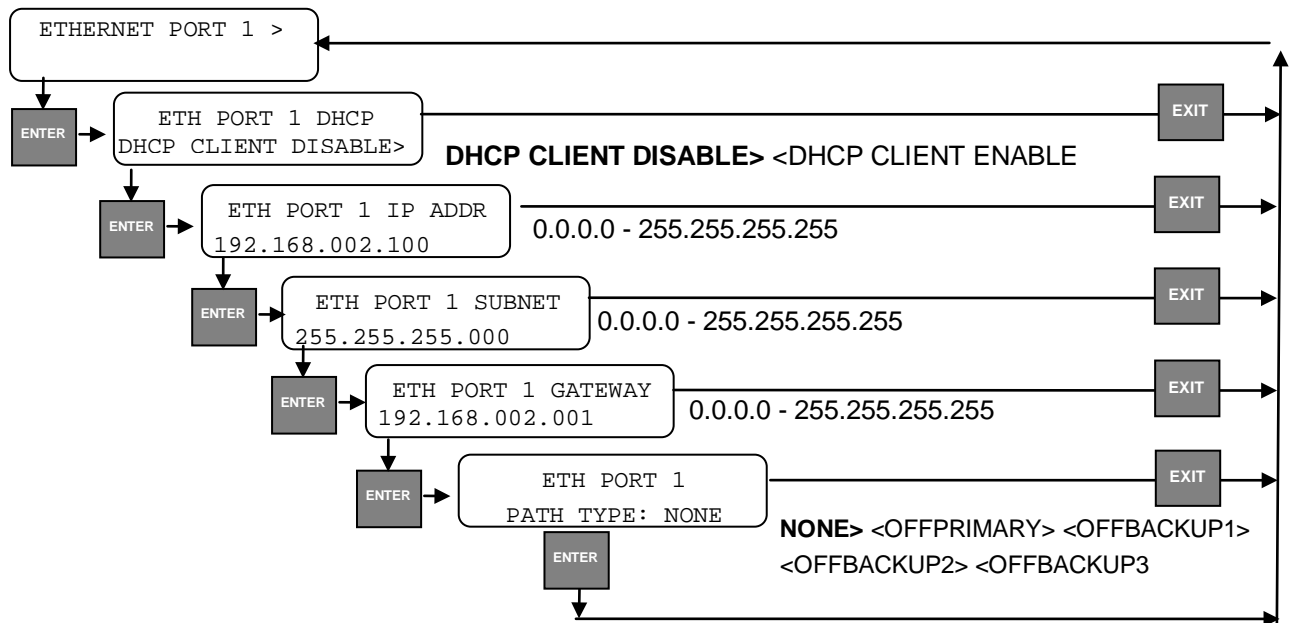

- Ethernet Ports 1 – 4 (DHCP Client Enable)**

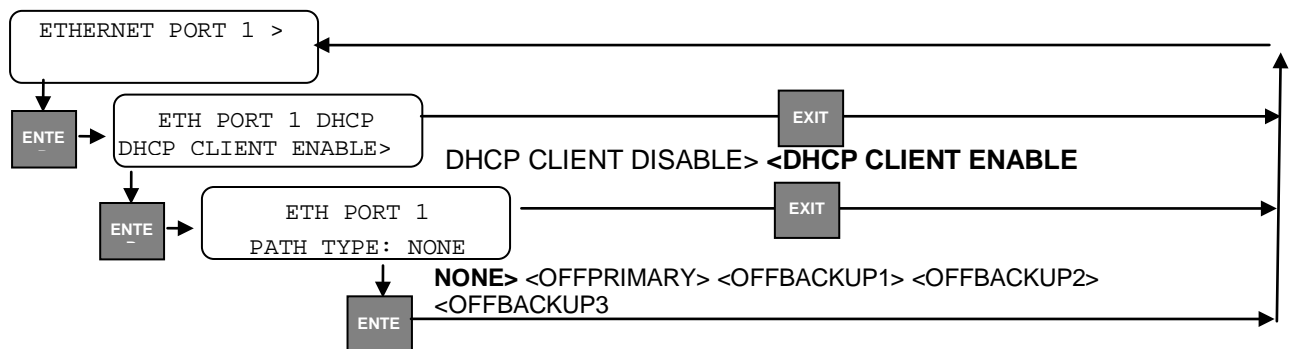

- Ethernet Ports 1 – 4 (Path Type: Office Primary, Office Backup 1, 2, & 3)

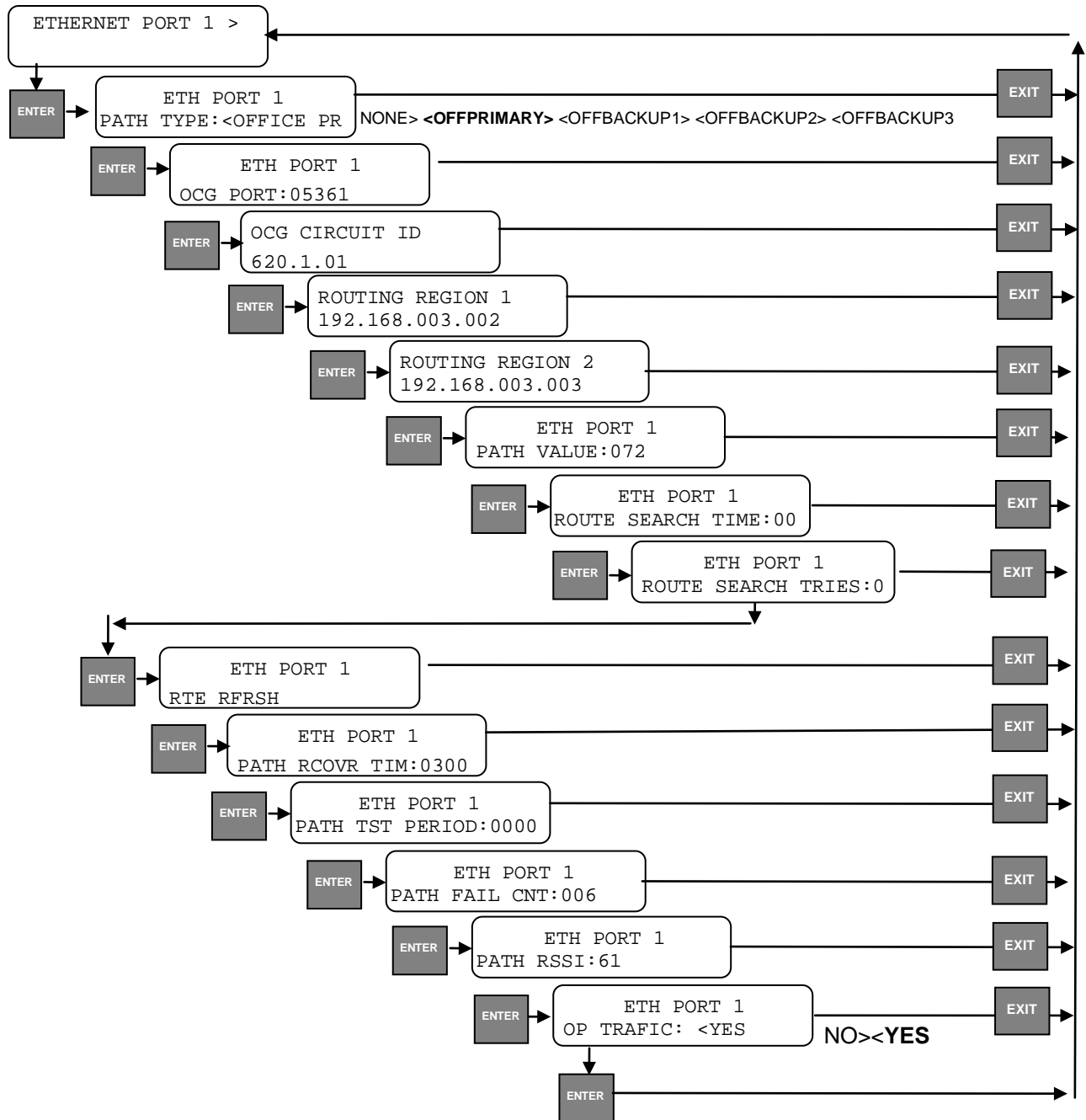

- **Logging Options**

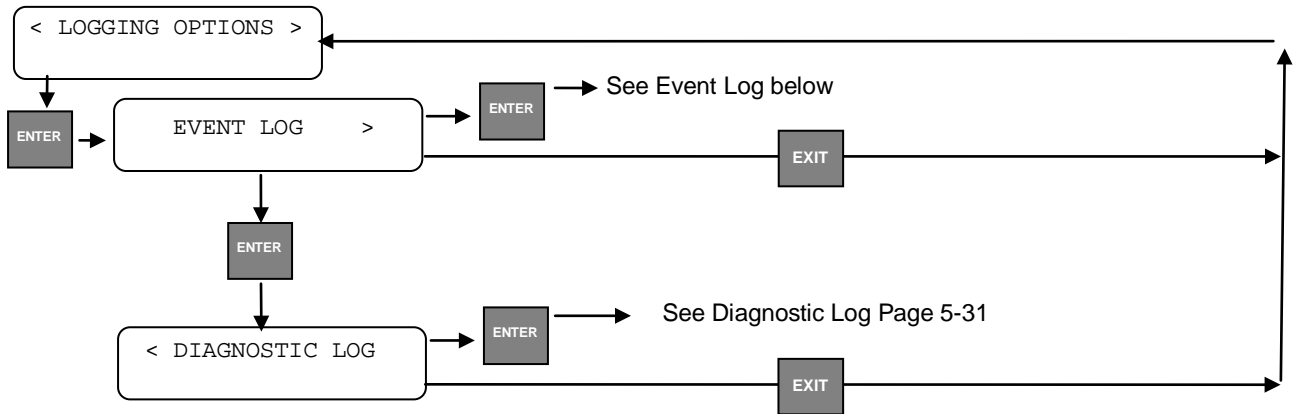

- **Event Log**

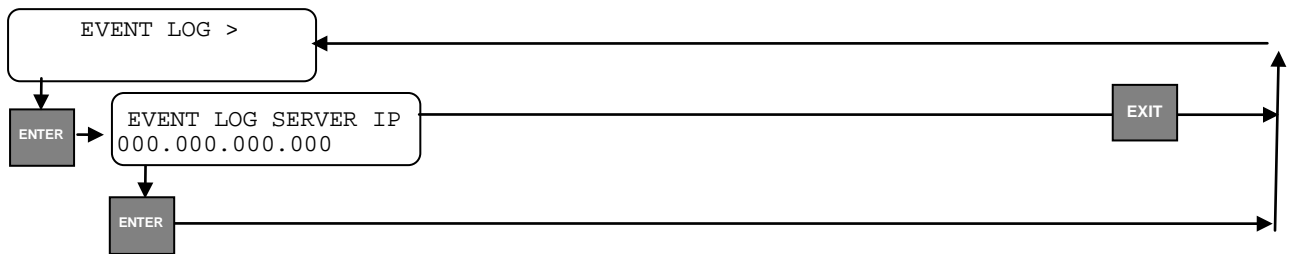

• Diagnostic Log

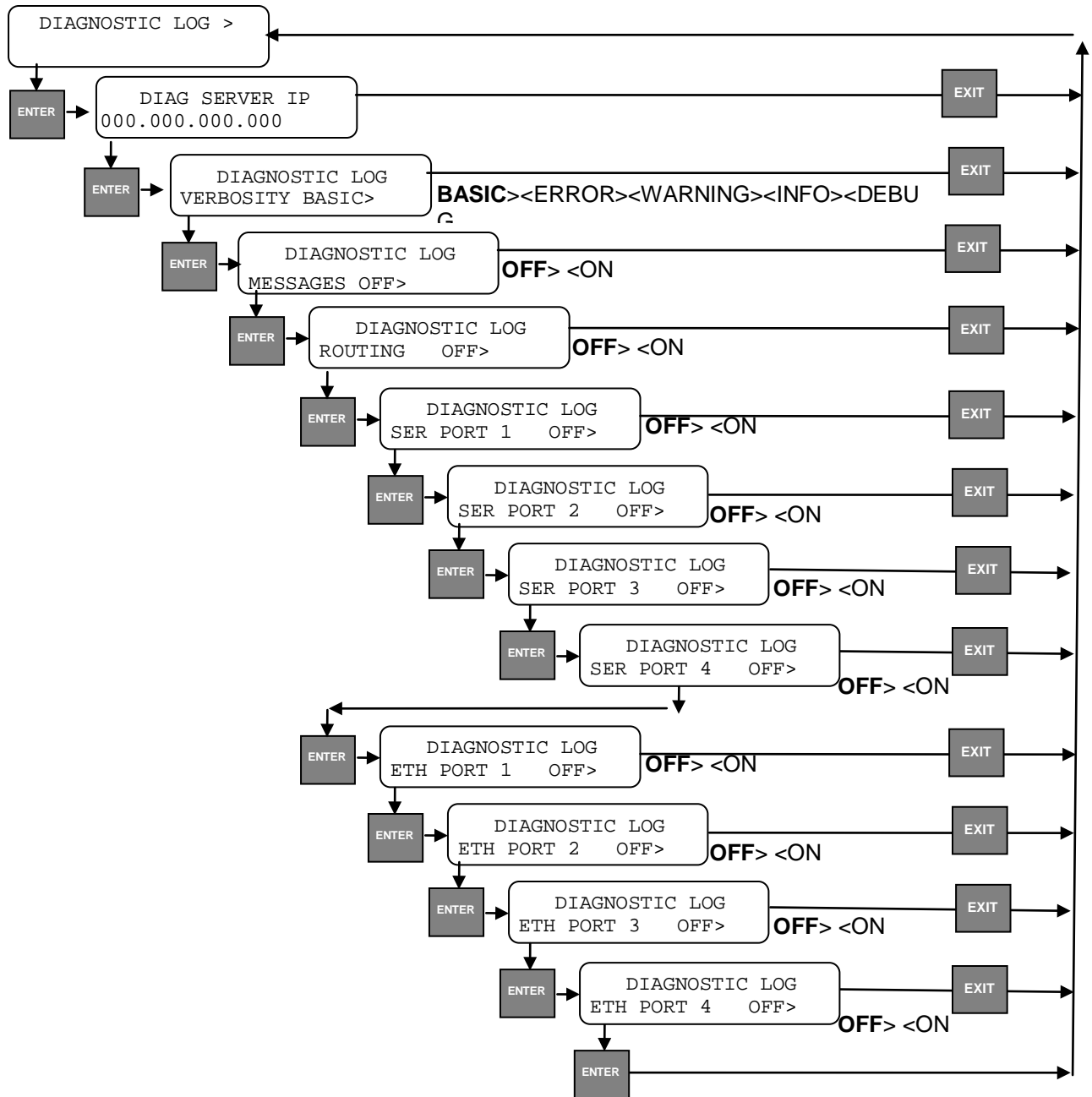

• **Digital Inputs**

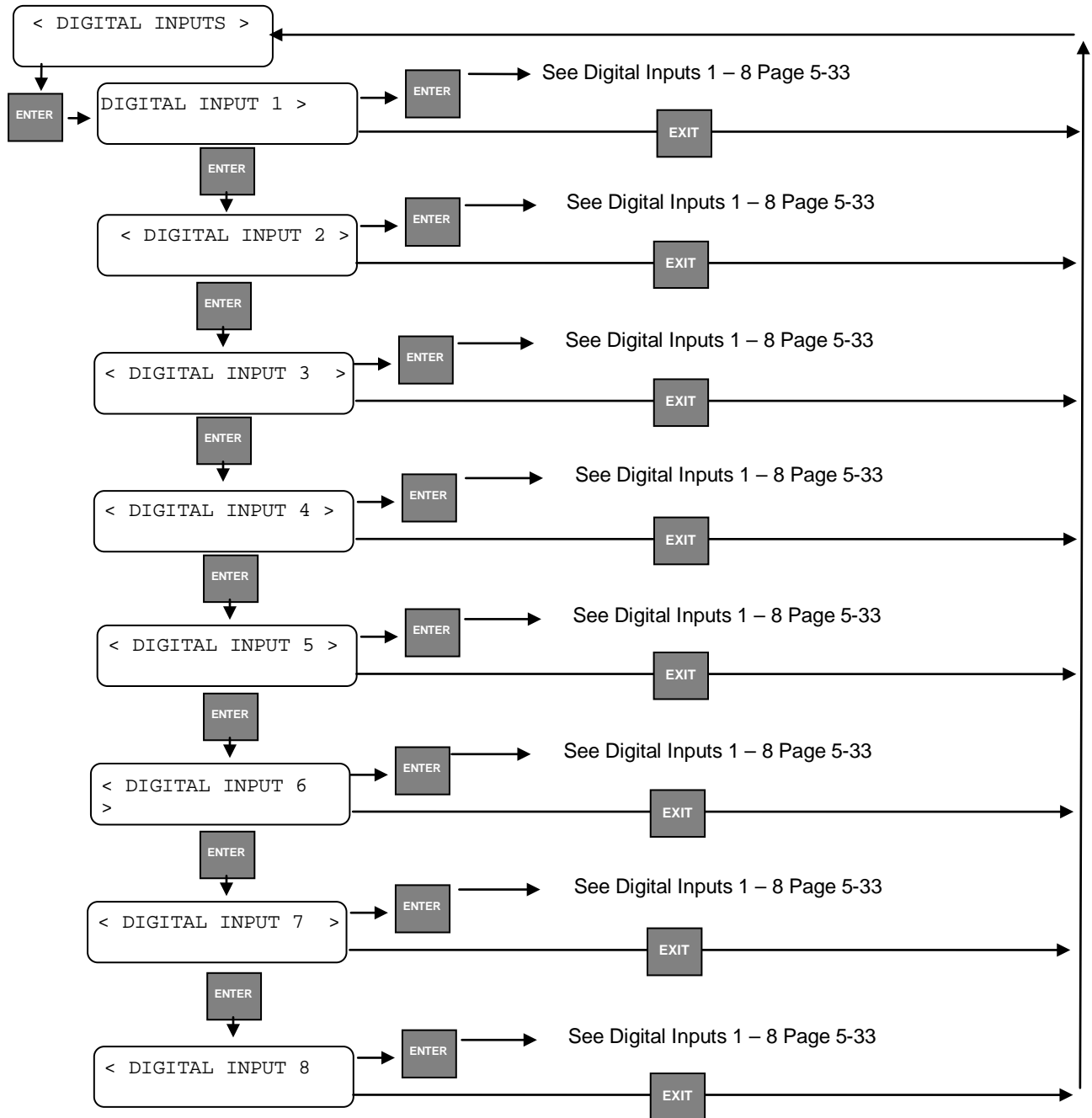

- Digital Inputs 1 - 8

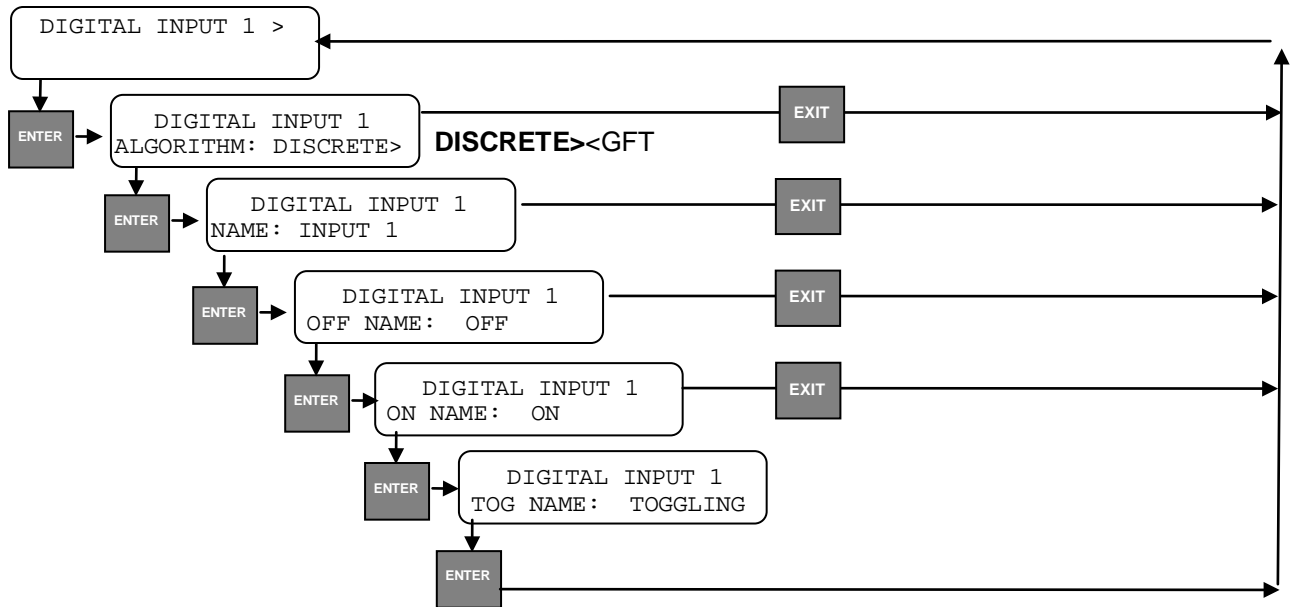

- **Analog Inputs**

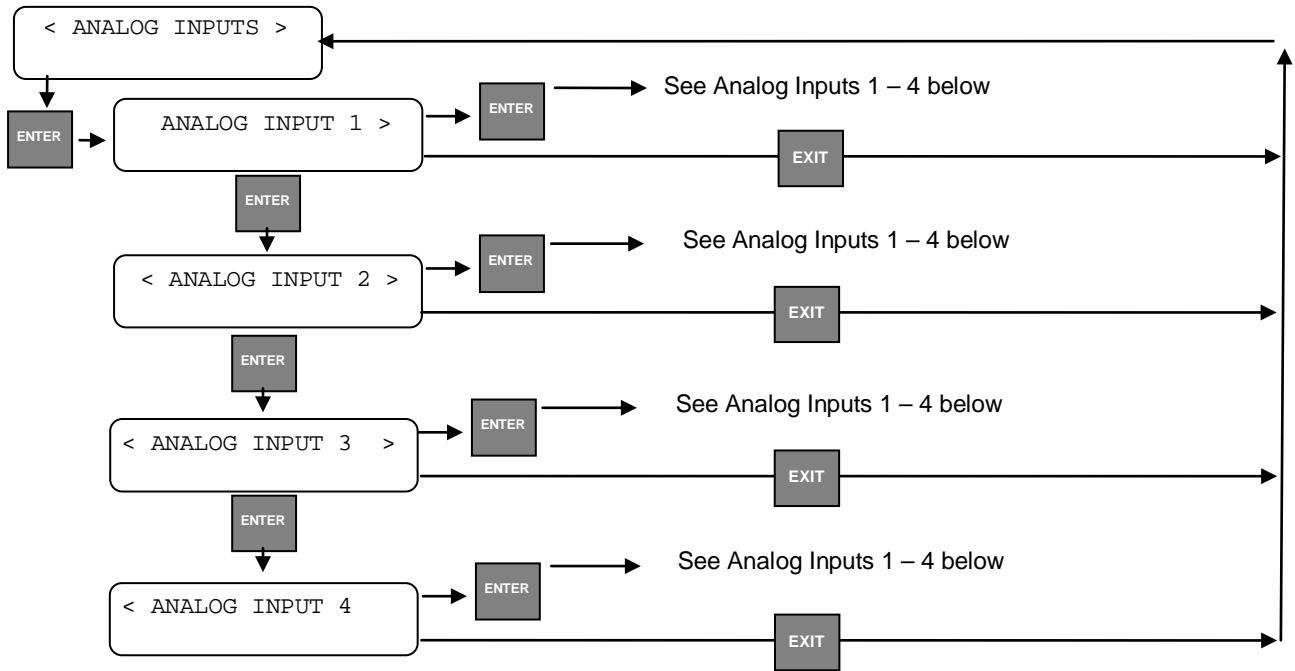

- **Analog Inputs 1 - 4**

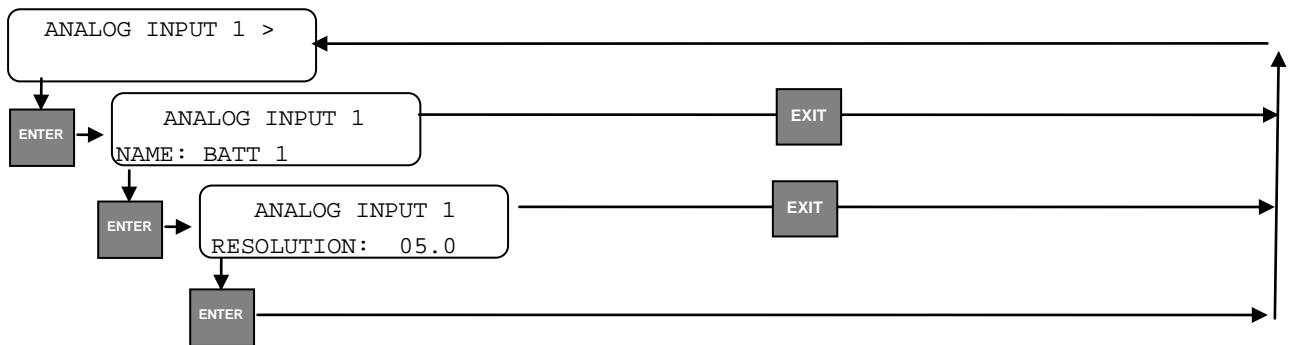

- **Relay Outputs**

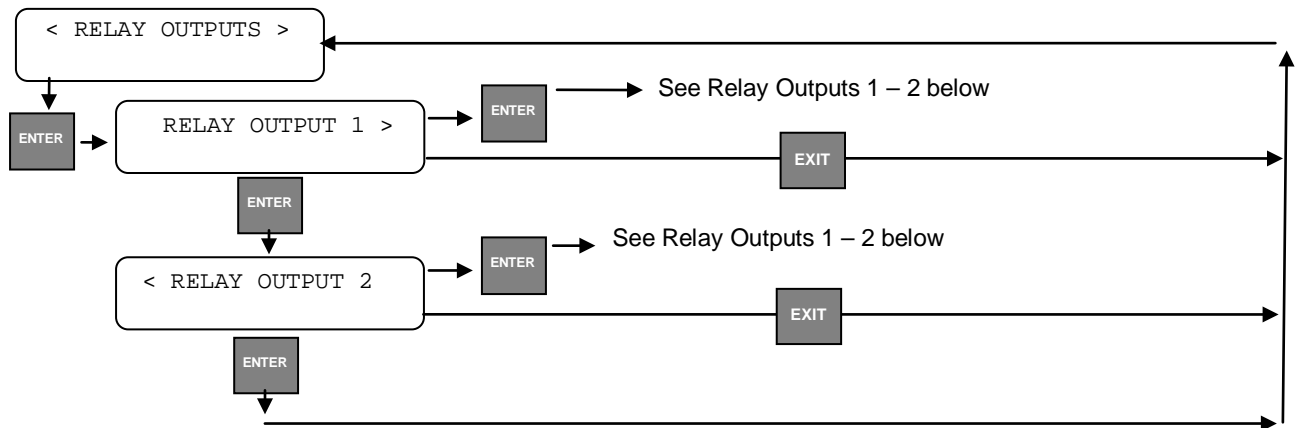

- **Relay Outputs 1 - 2**

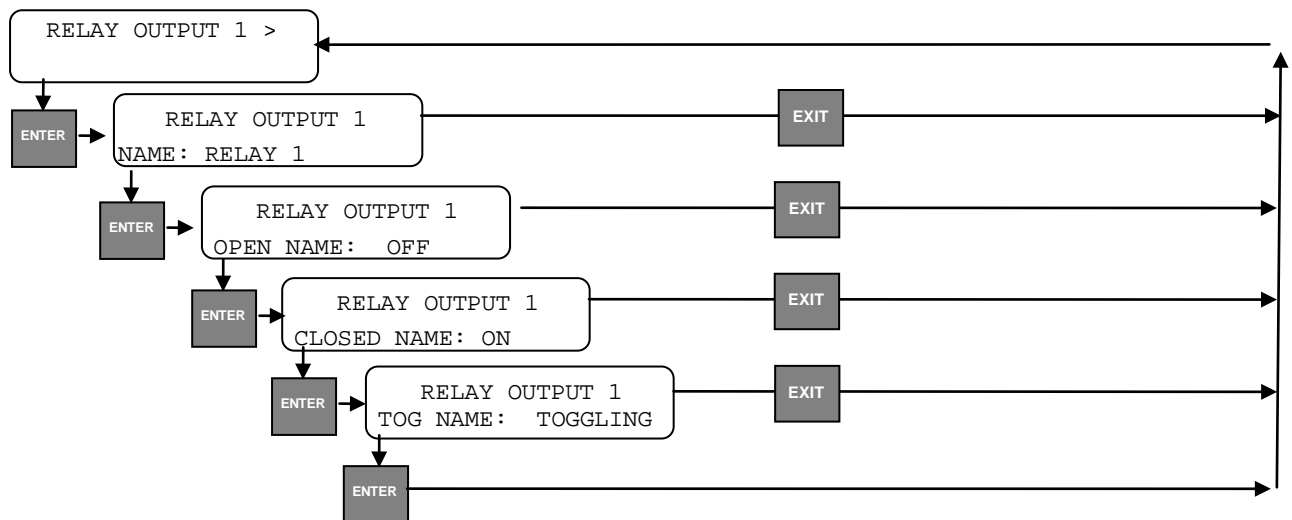

- **DC Code Line - NONE**

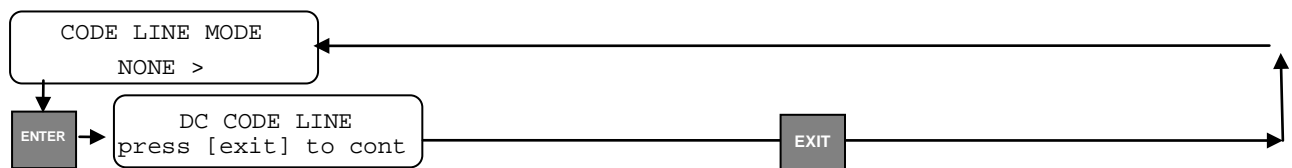

• DC Code Line – K2

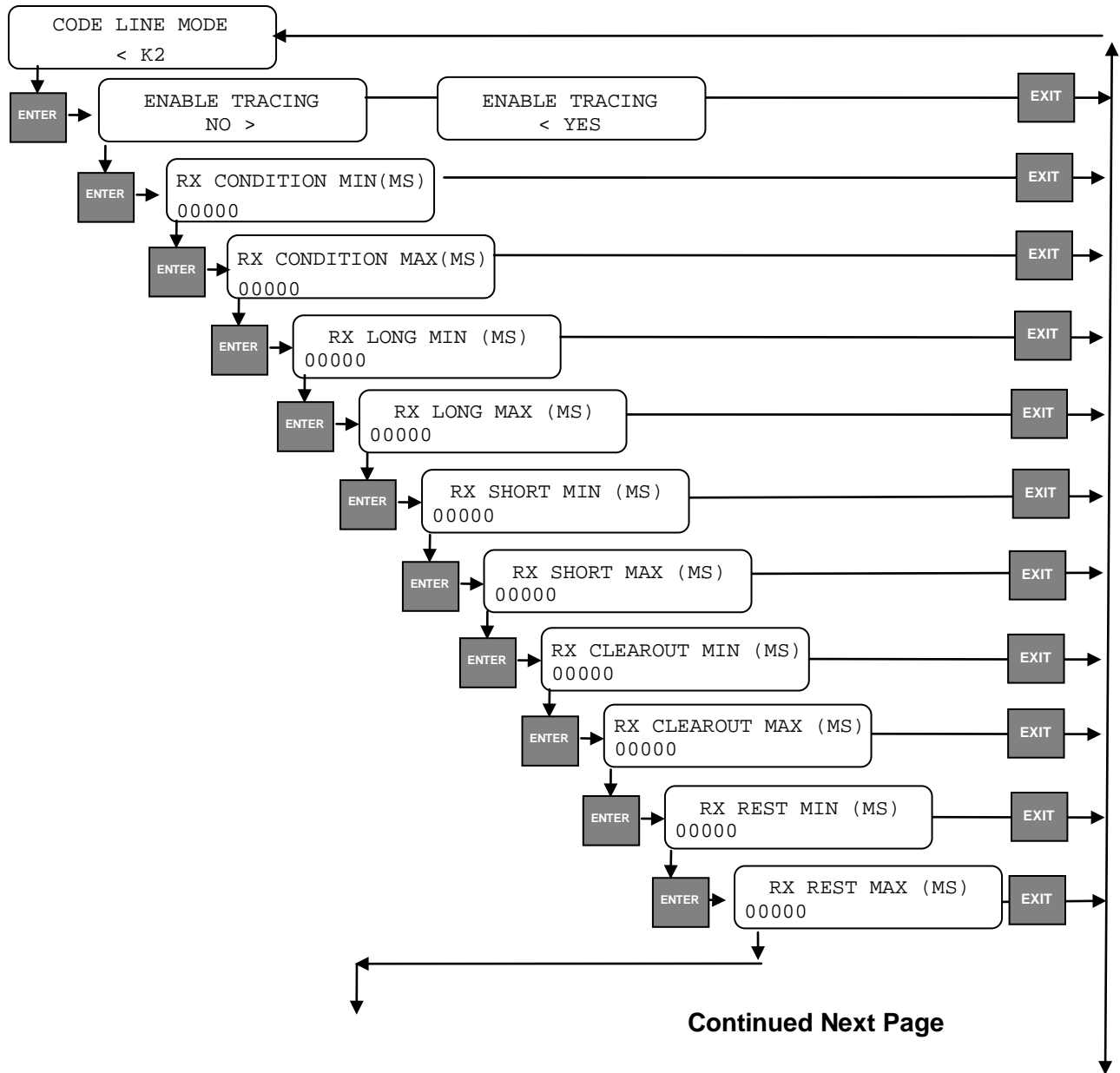

Continued Next Page

Continued from previous page

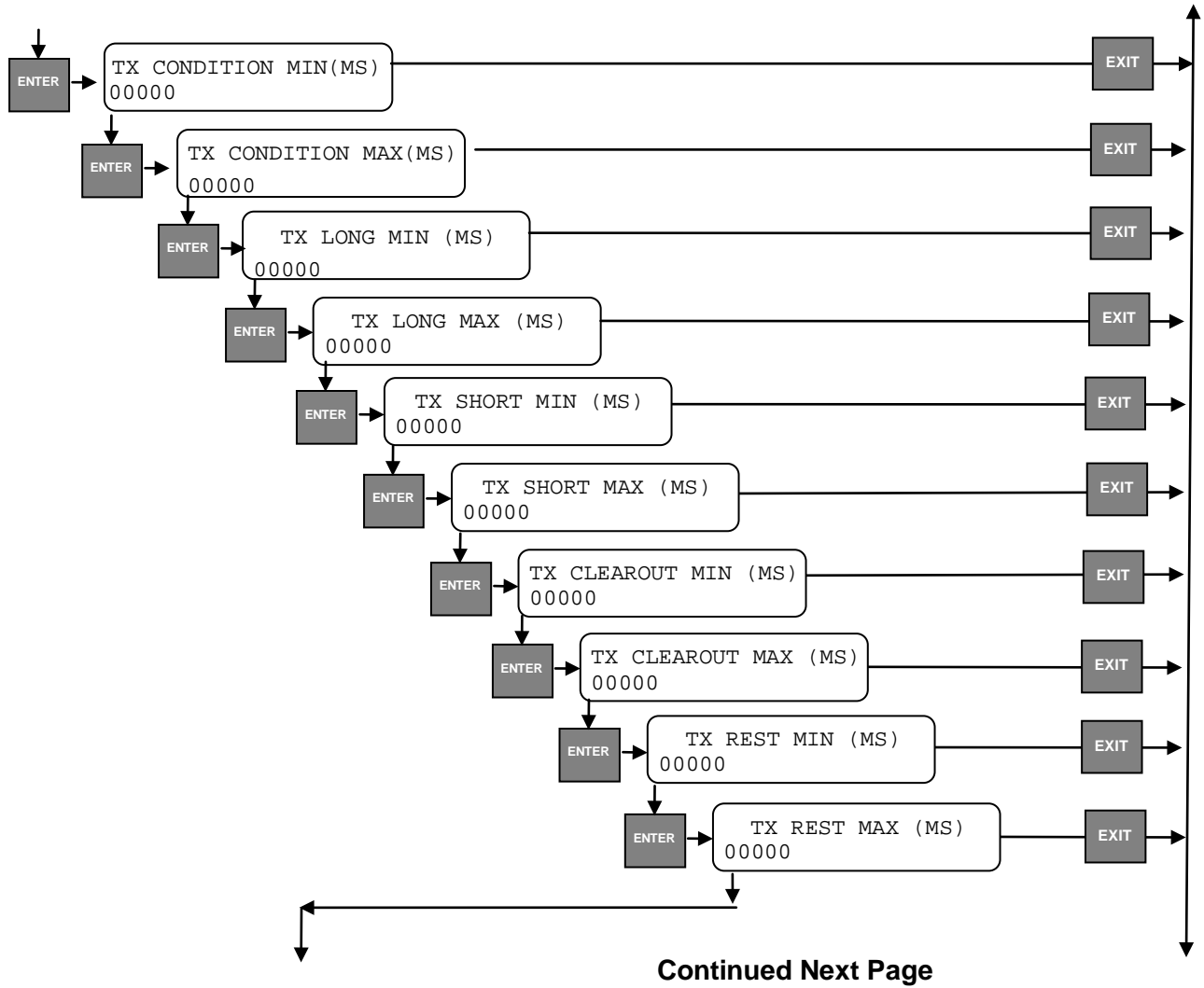

Continued from previous page

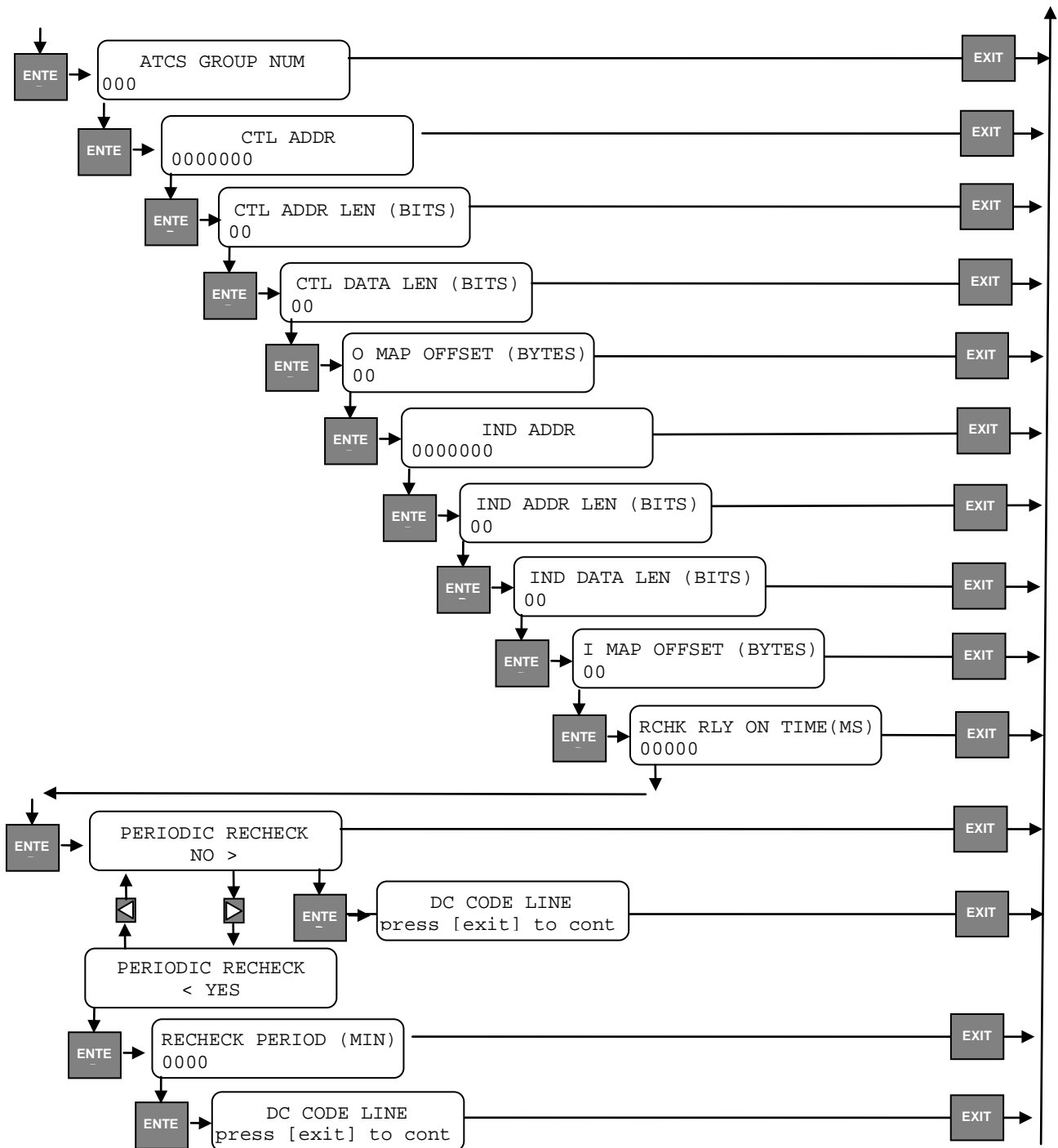

- DNS

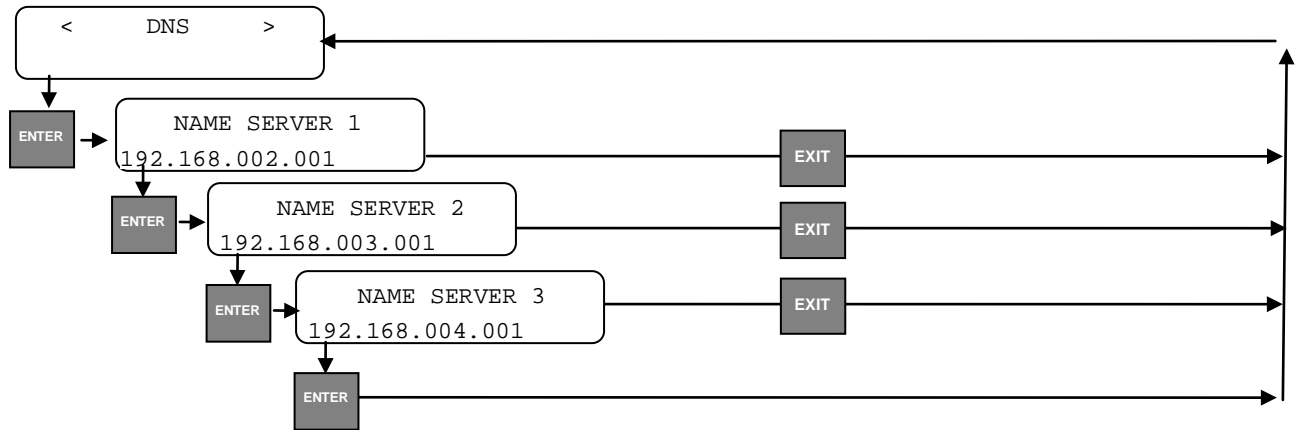

• **SNMP Trap Handling**

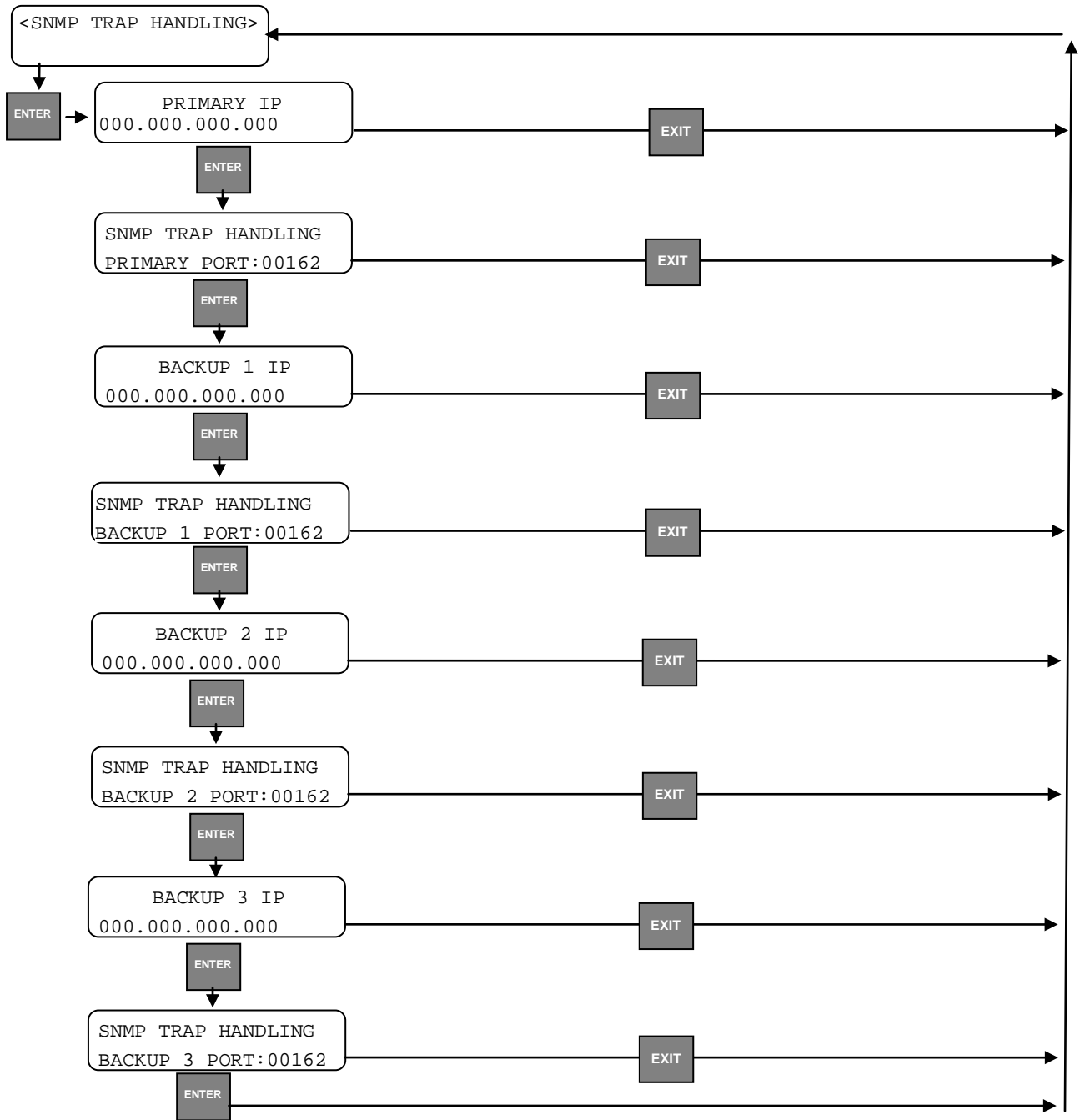

• **Modules**

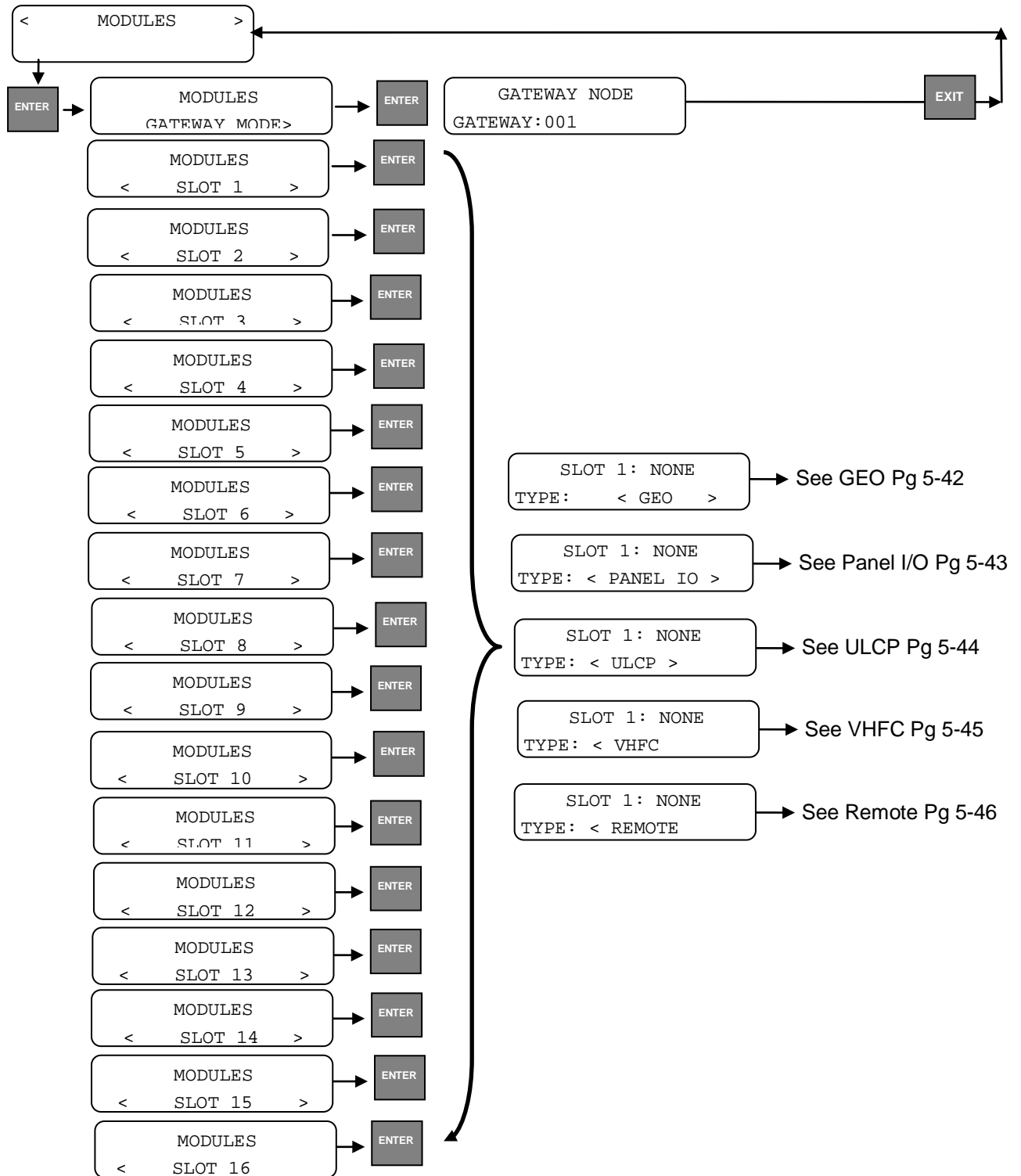

• **Modules - GEO**

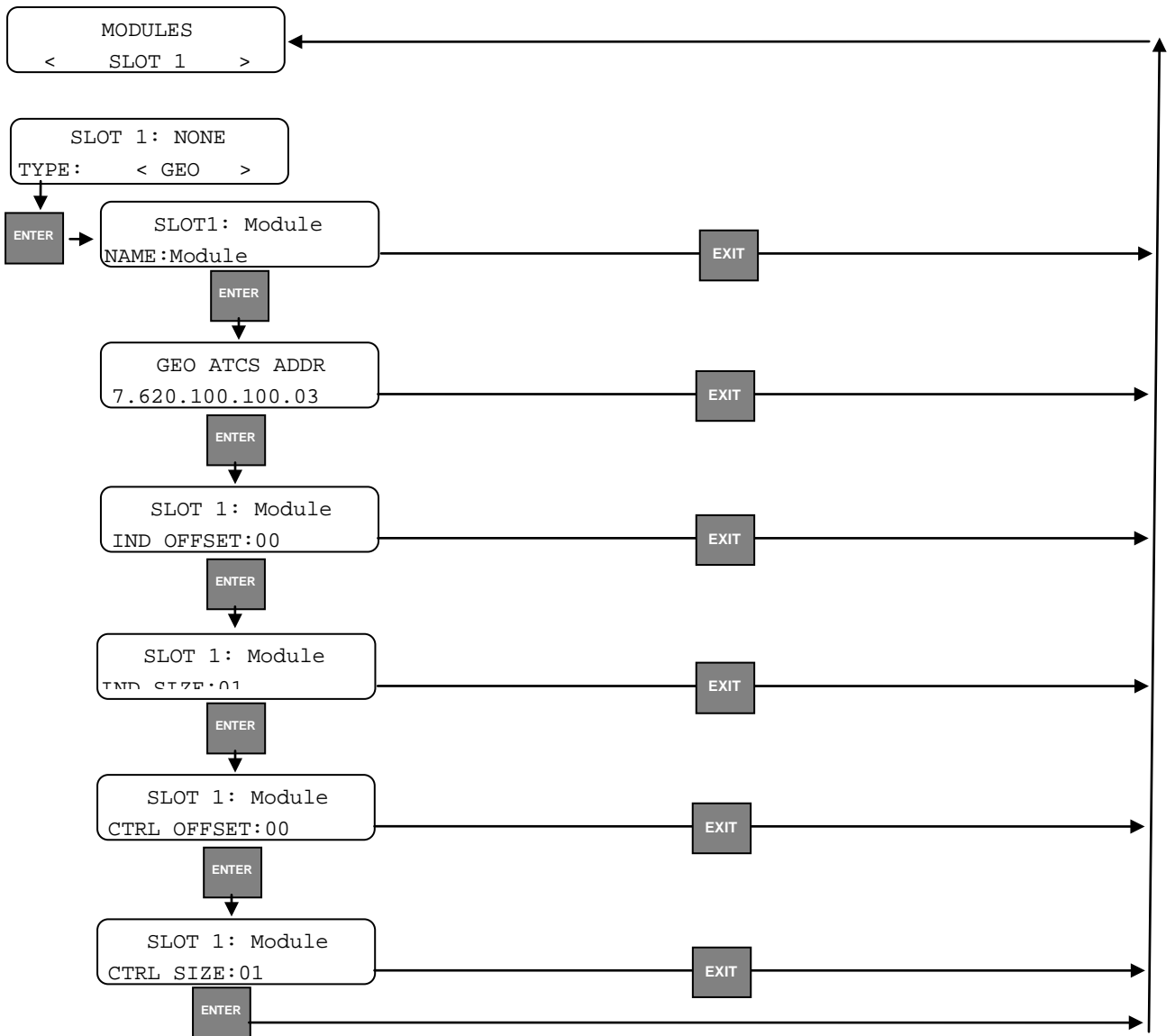

• **Modules – Panel I/O**

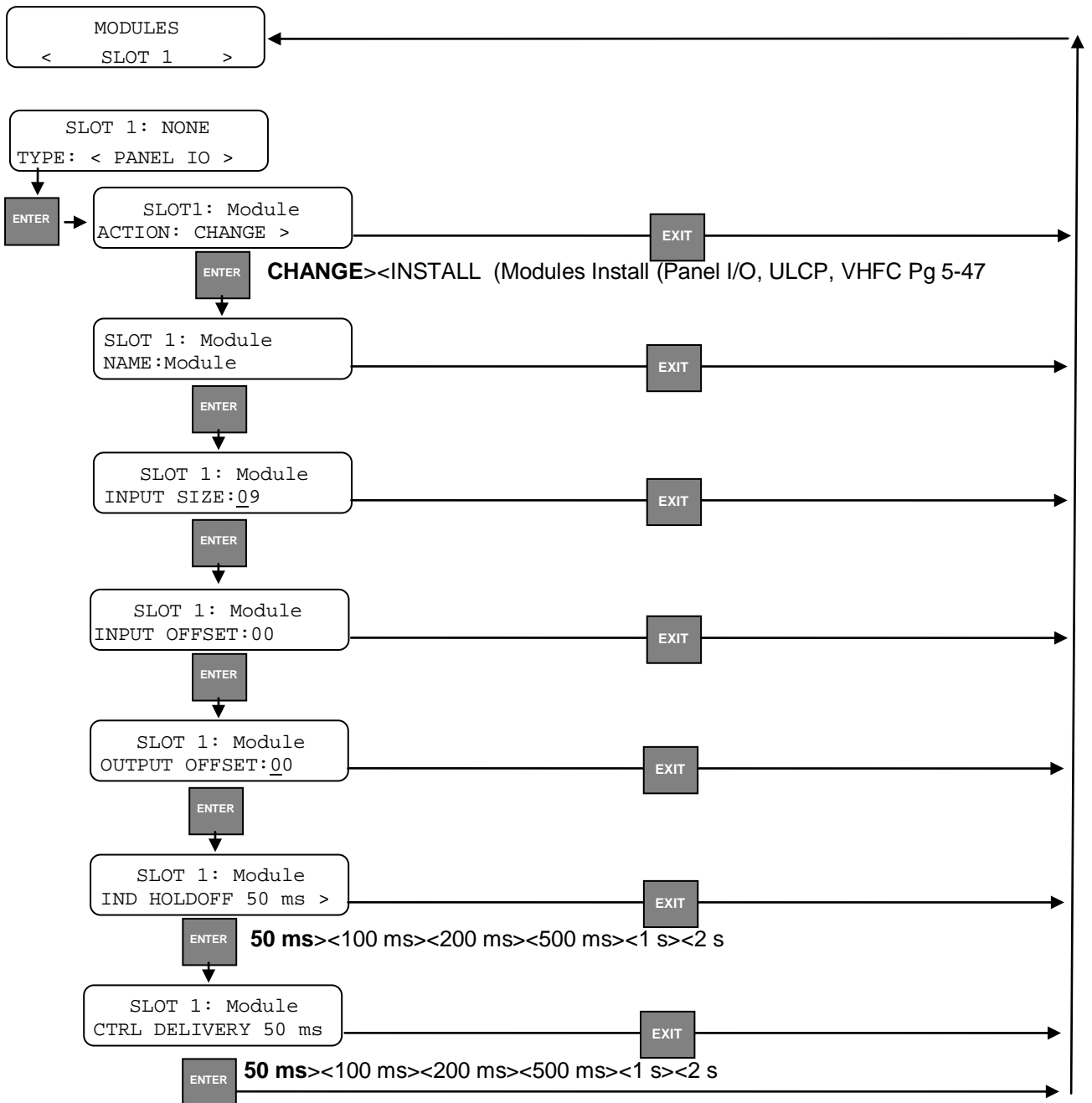

• **Modules – ULCP**

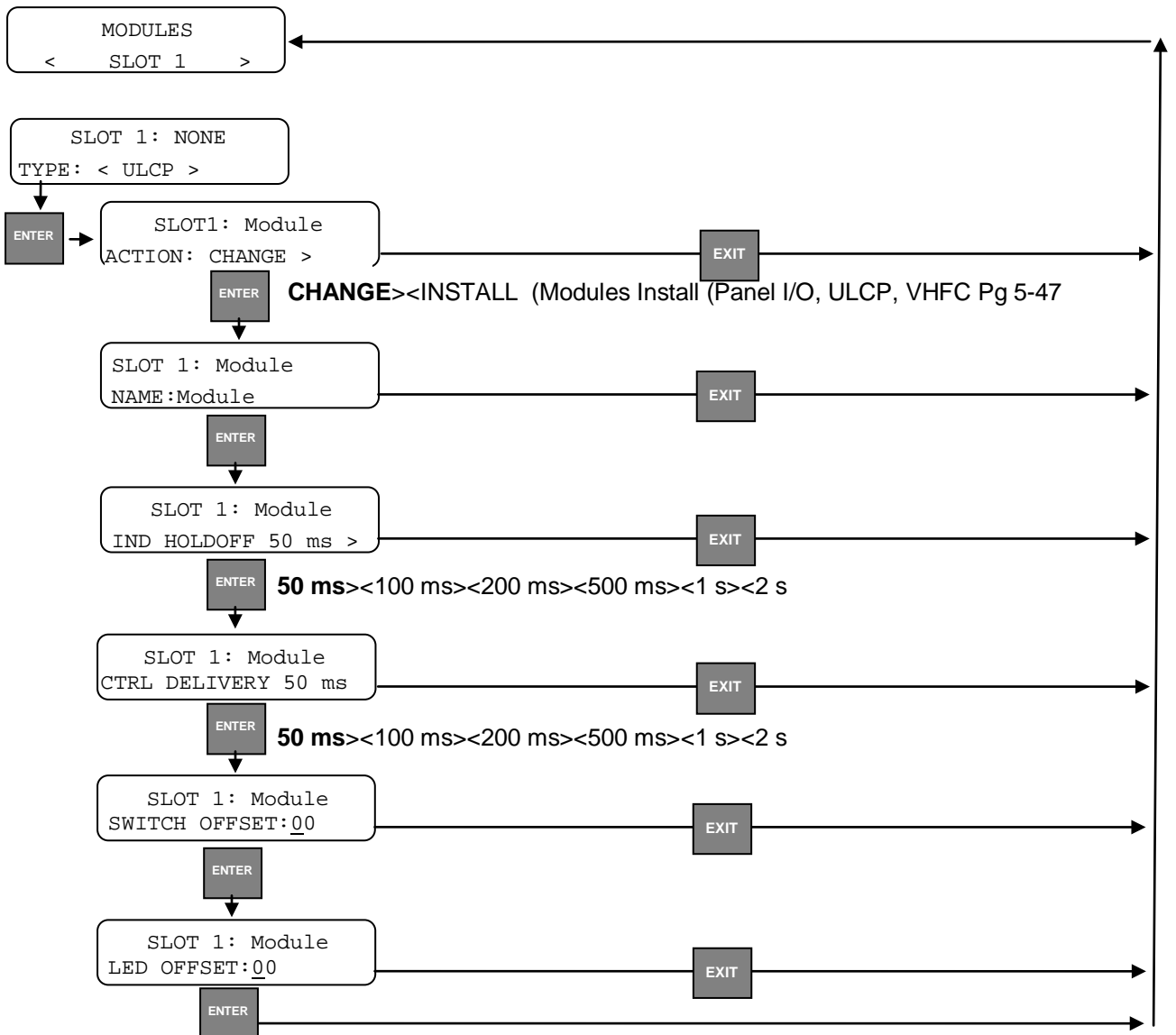

• Modules – VHFC

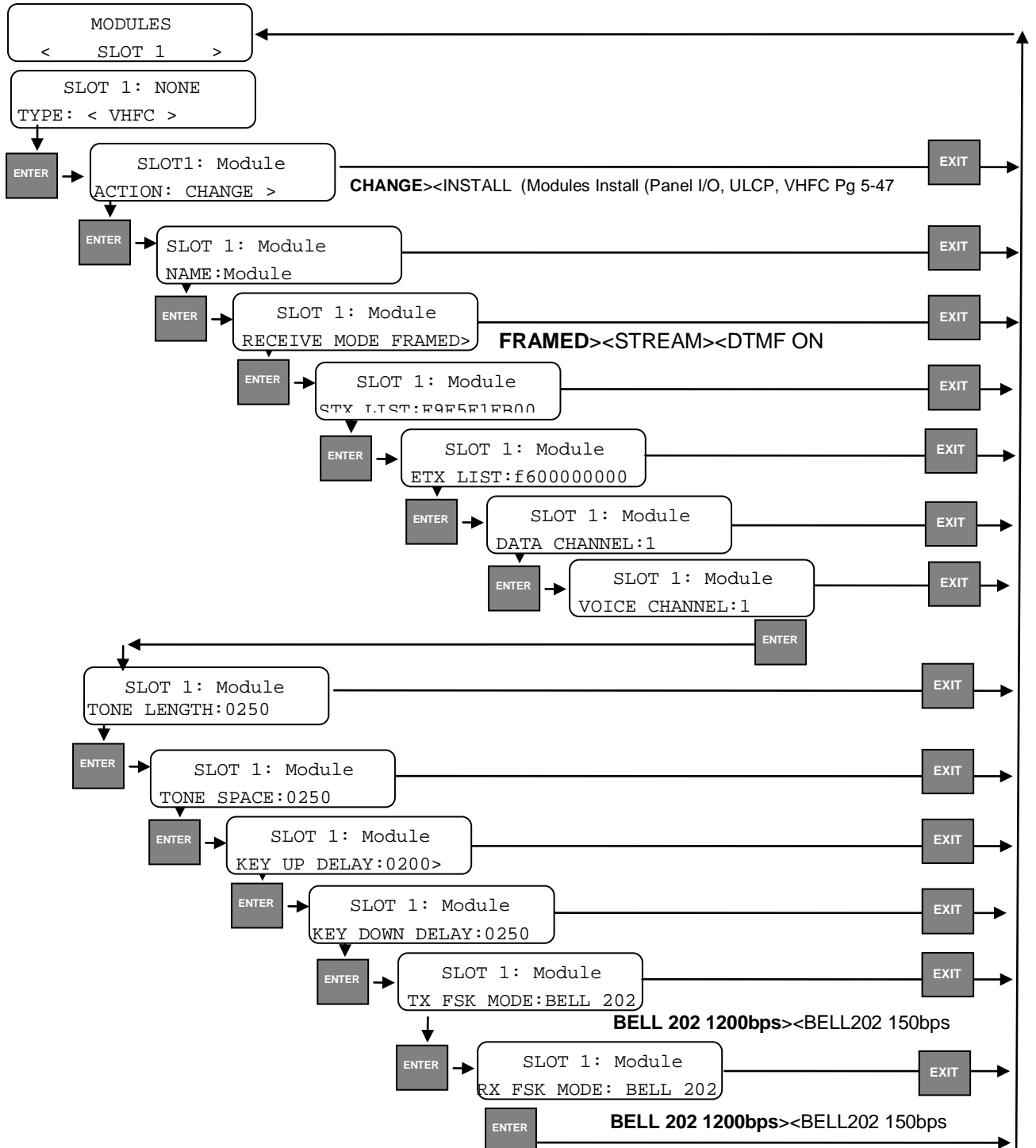

• **Modules – Remote**

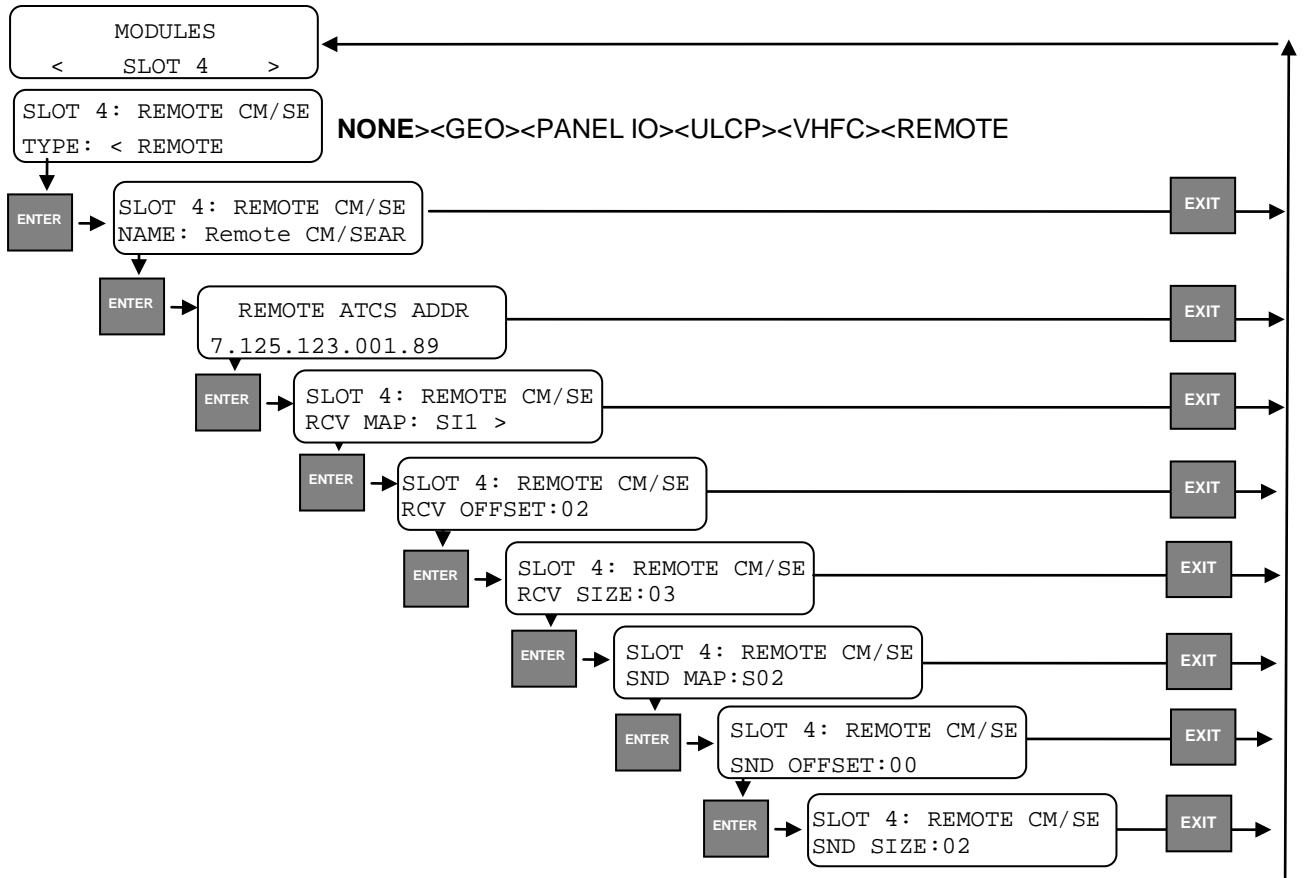

See Table 4-6 for configurable parameters specific to the Remote CM/SEAR II.

• **Modules Install (Panel I/O, ULCP, VHFC)**

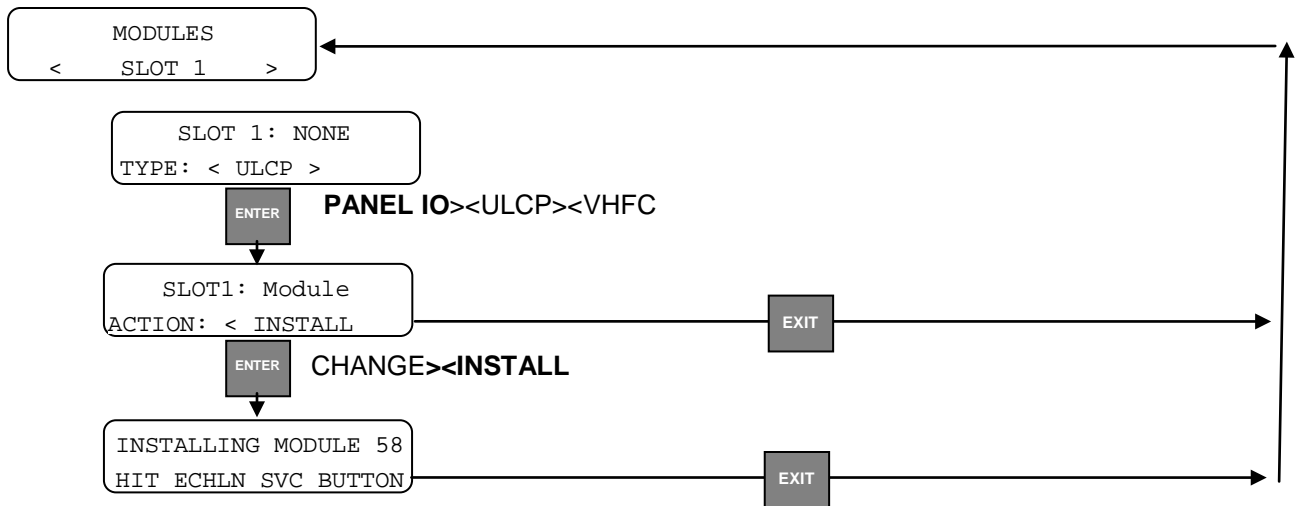

• **WAMS**

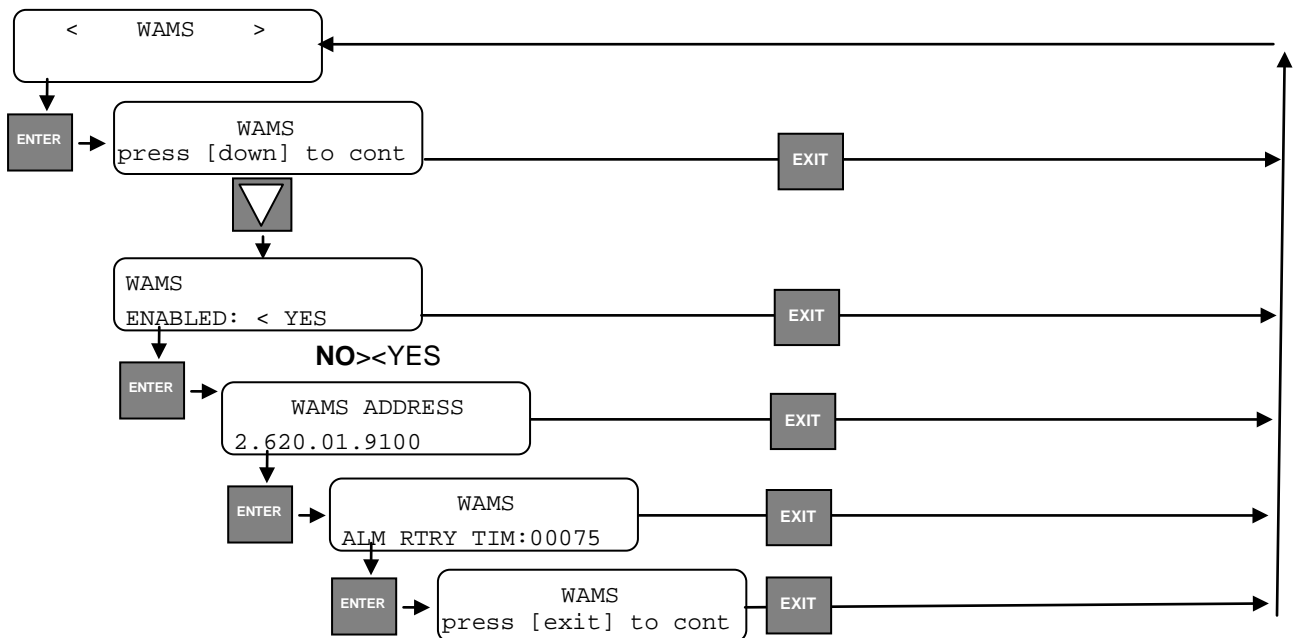

• WSA/S2

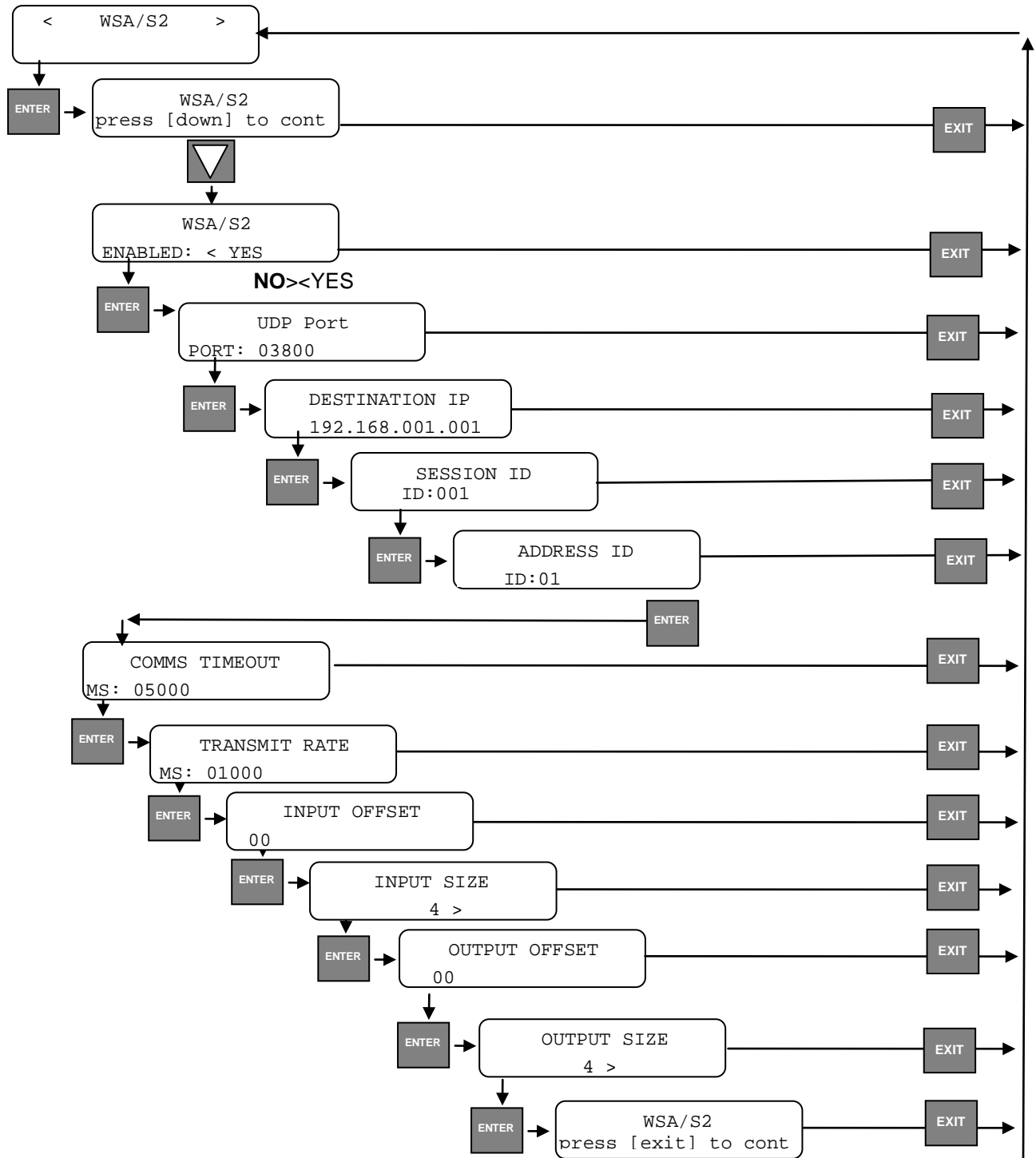

• **ATCS Router**

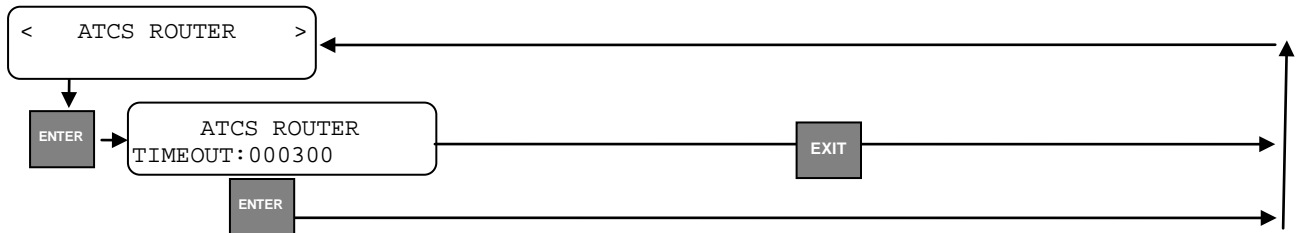

• **GPS**

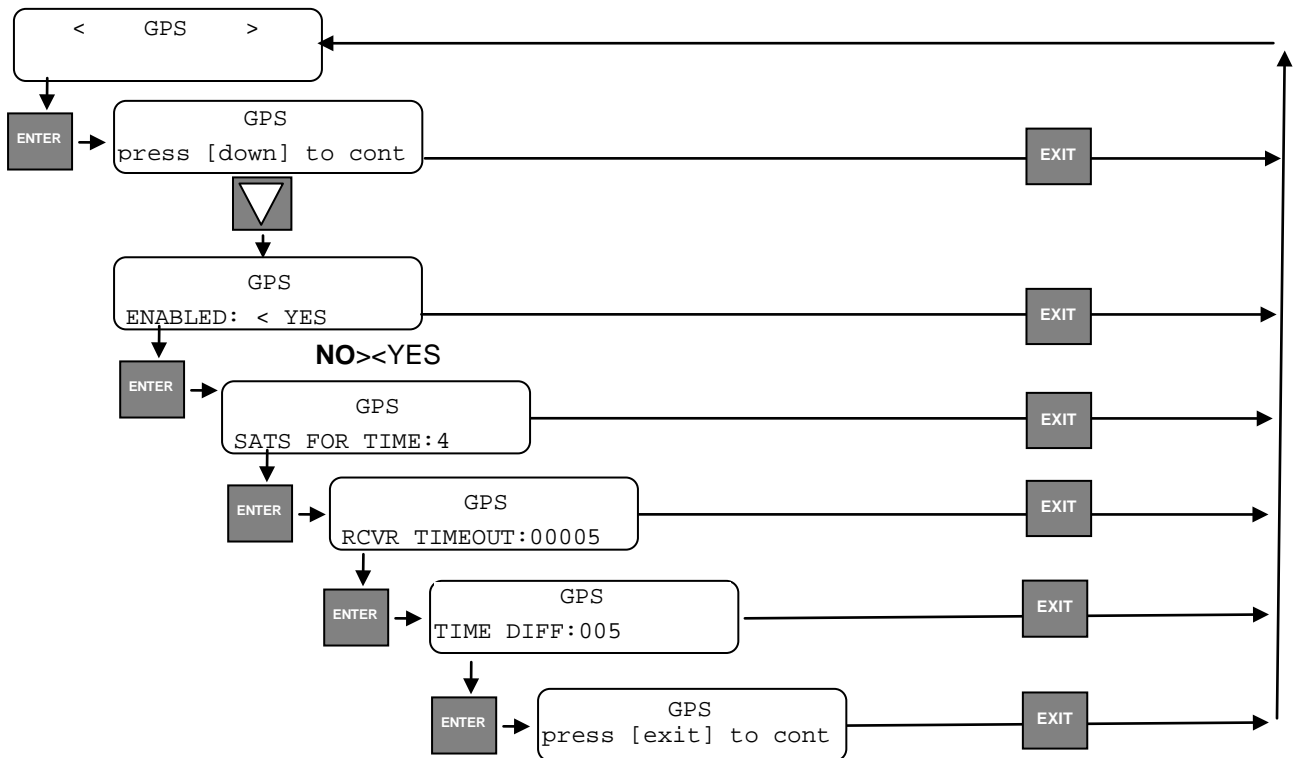

NOTE

The GPS feature is no longer available in Communications Manager Model 53475 Revision C3 or later.

- **Advanced**

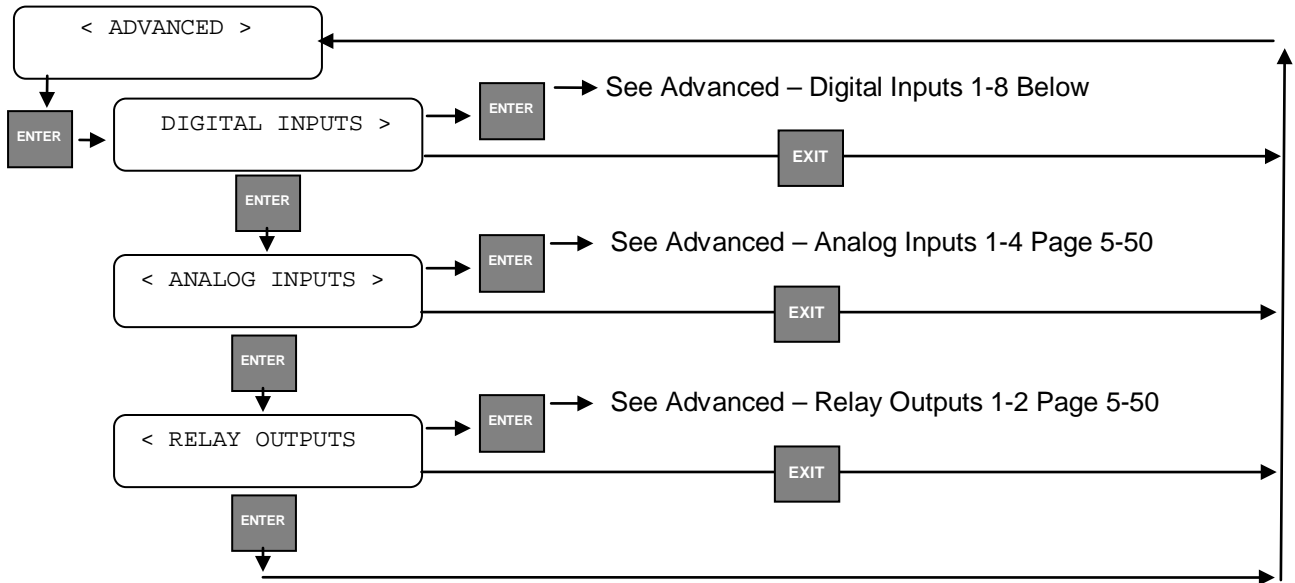

- **Advanced – Digital Inputs 1 - 8**

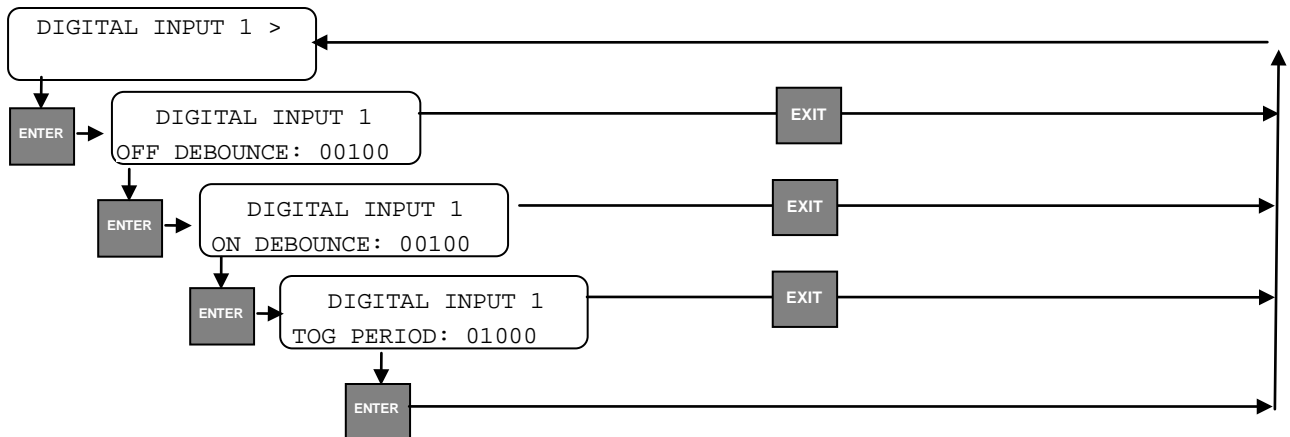

- **Advanced – Analog Inputs 1 - 4**

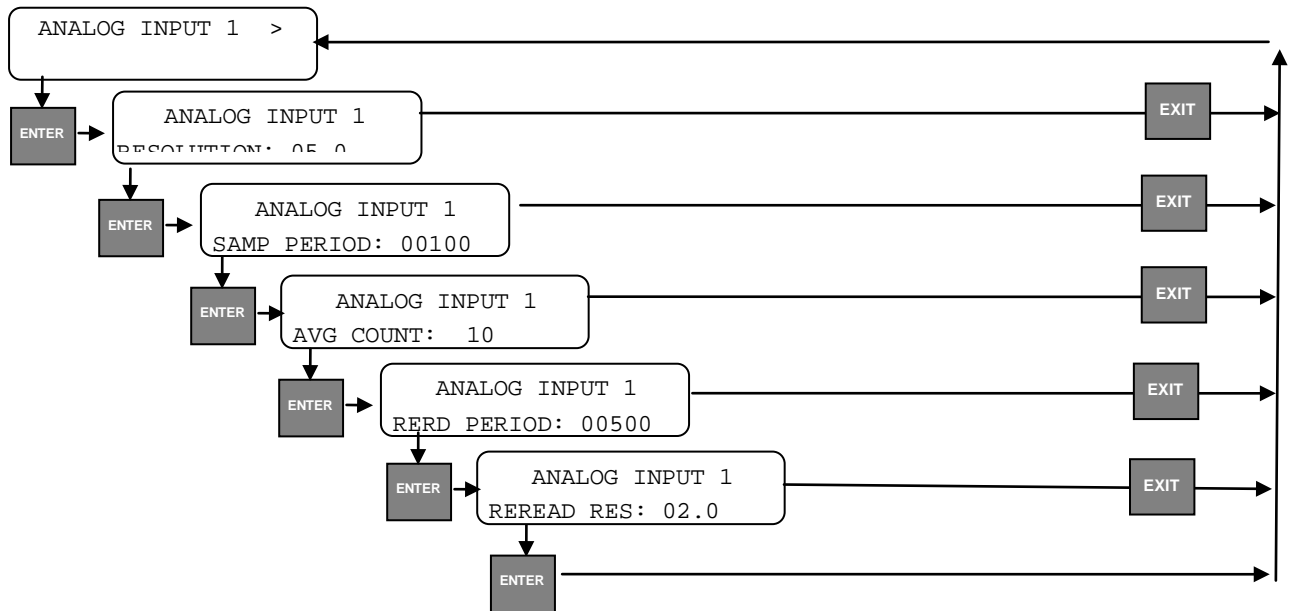

- **Advanced – Relay Outputs 1 - 2**

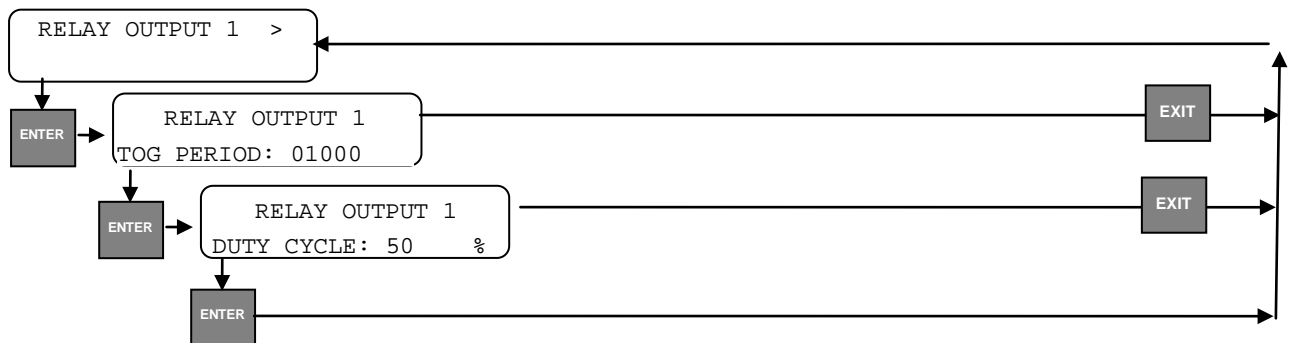

- Password

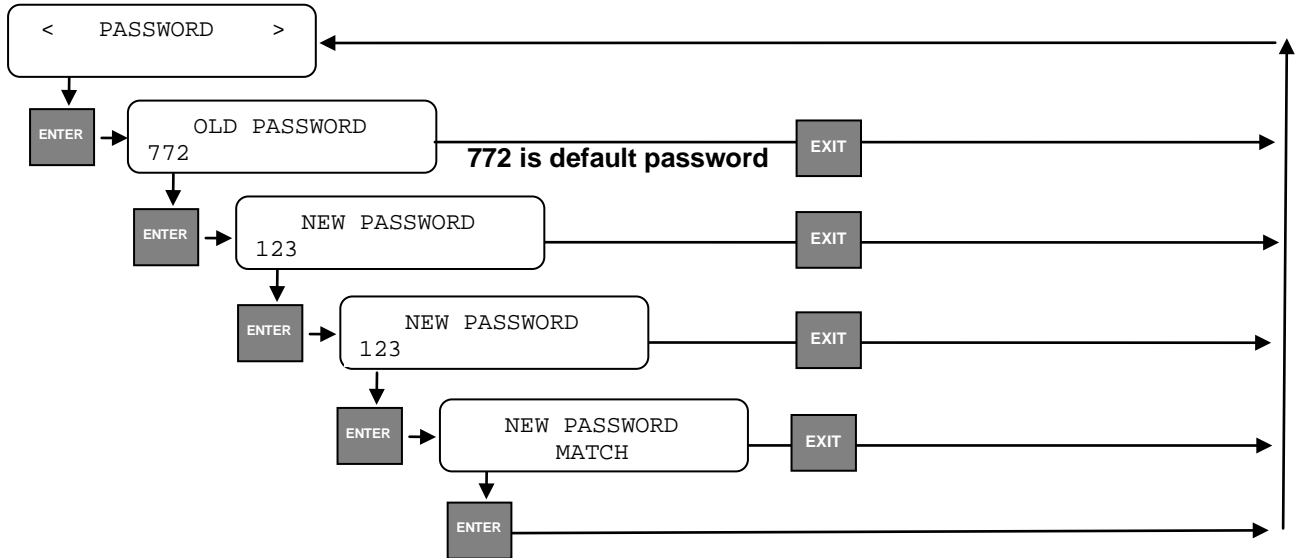

- Restore Defaults

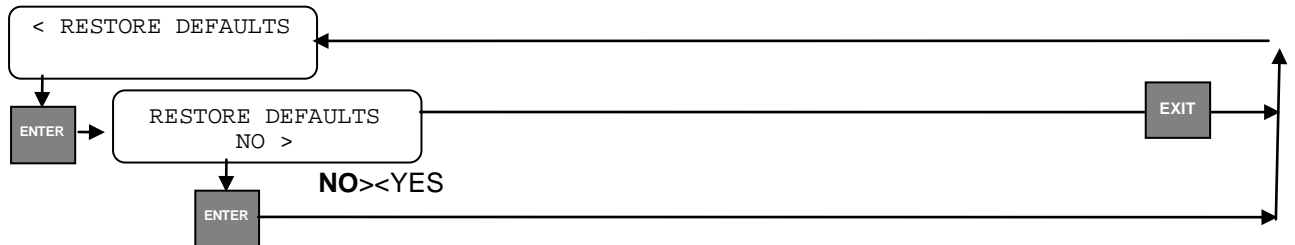

5.3.1.6 Monitor I/O

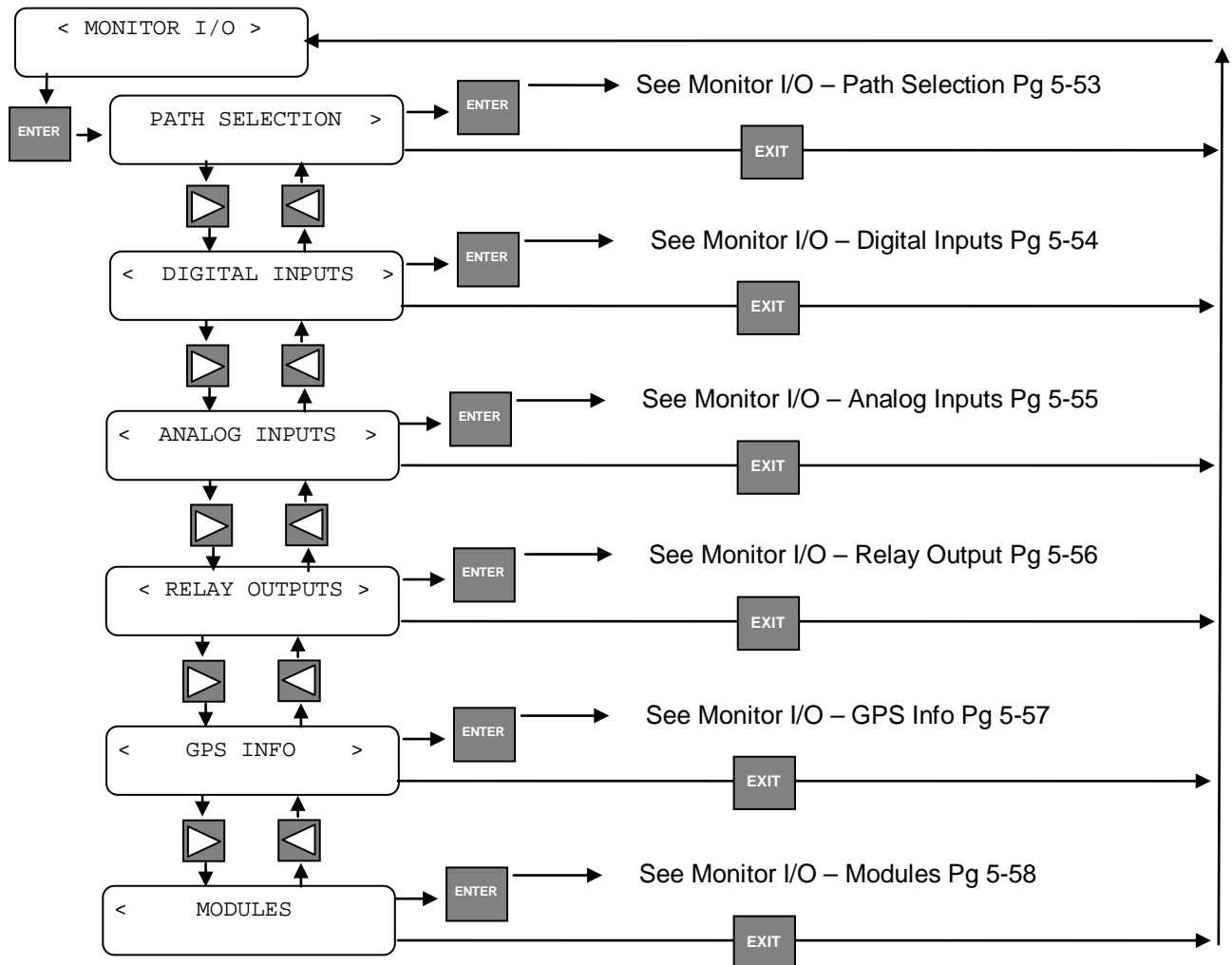

- **Monitor I/O – Path Selection**

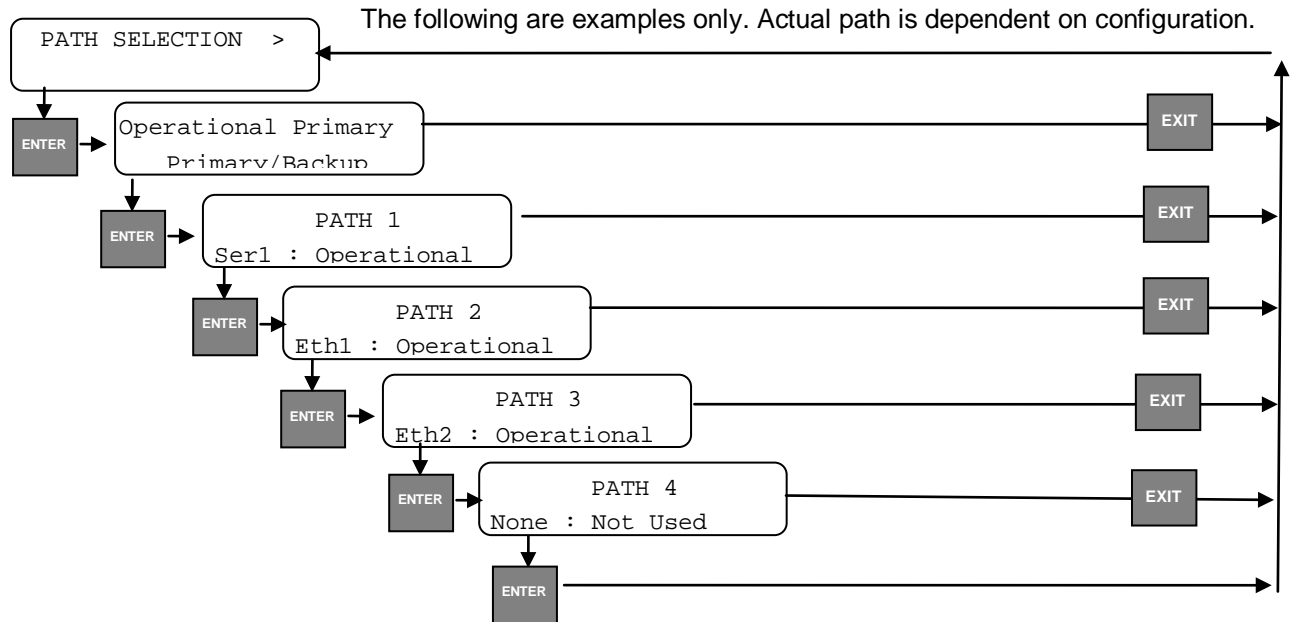

• Monitor I/O – Digital Inputs

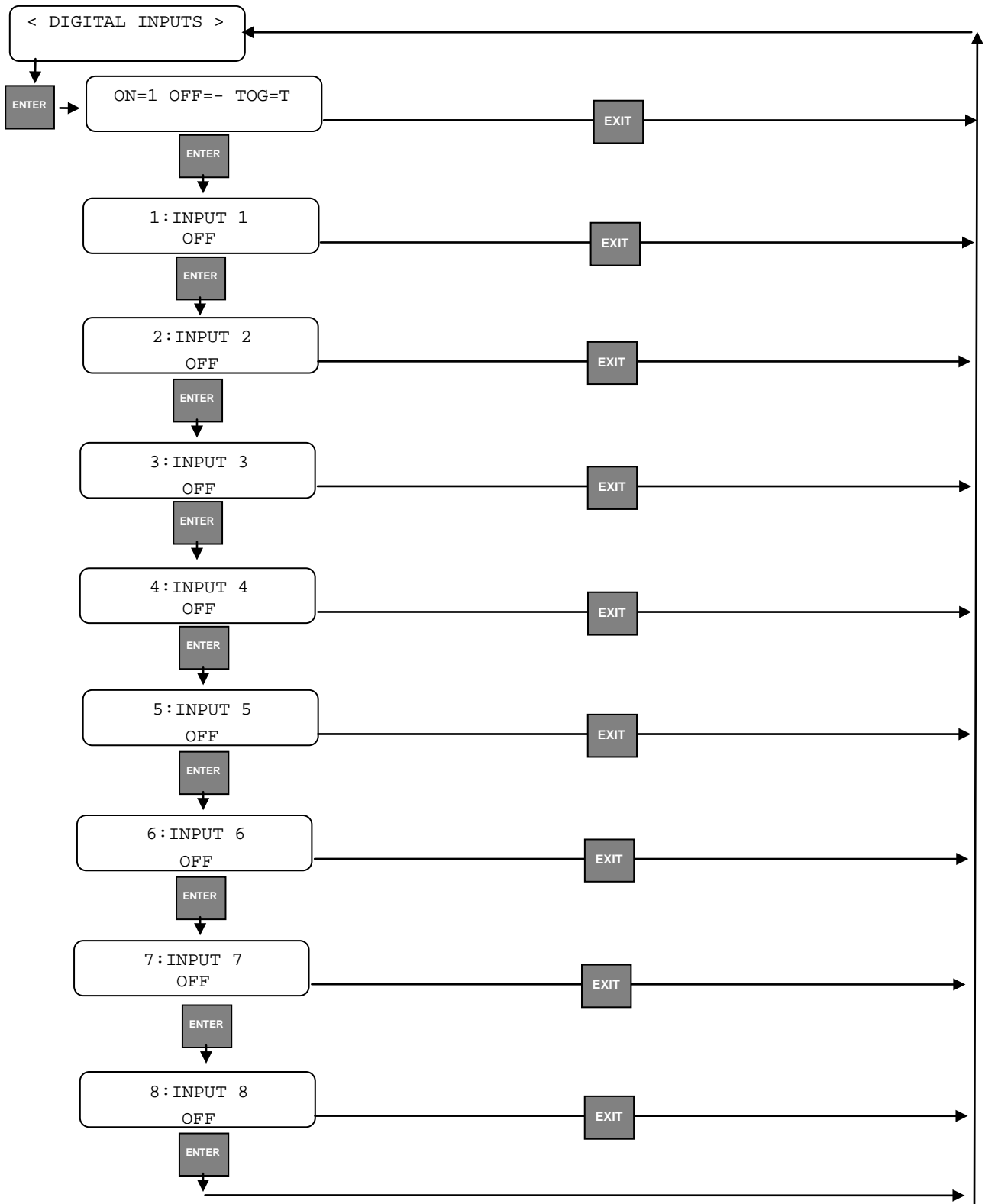

- **Monitor I/O – Analog Inputs**

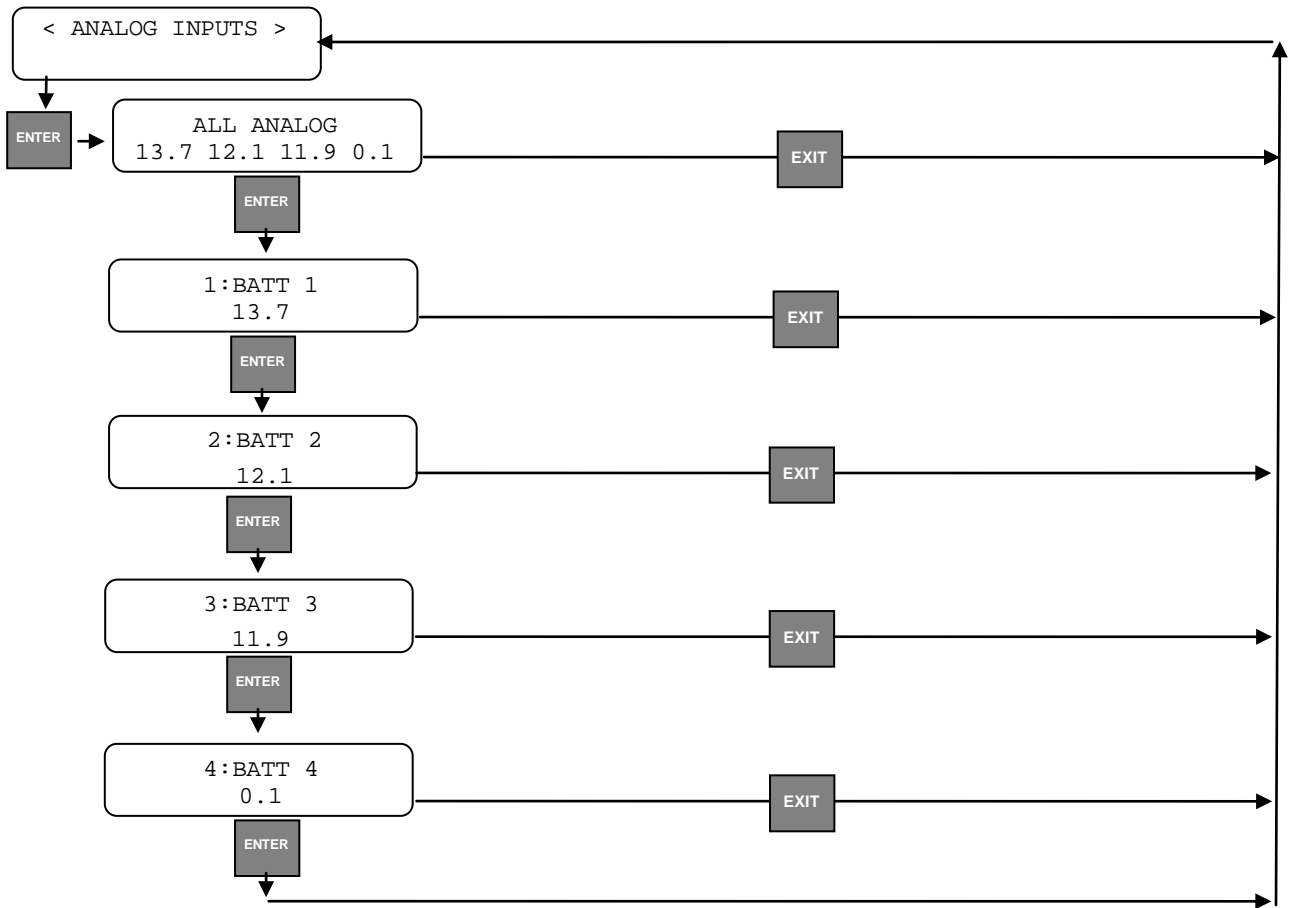

• Monitor I/O – Relay Output

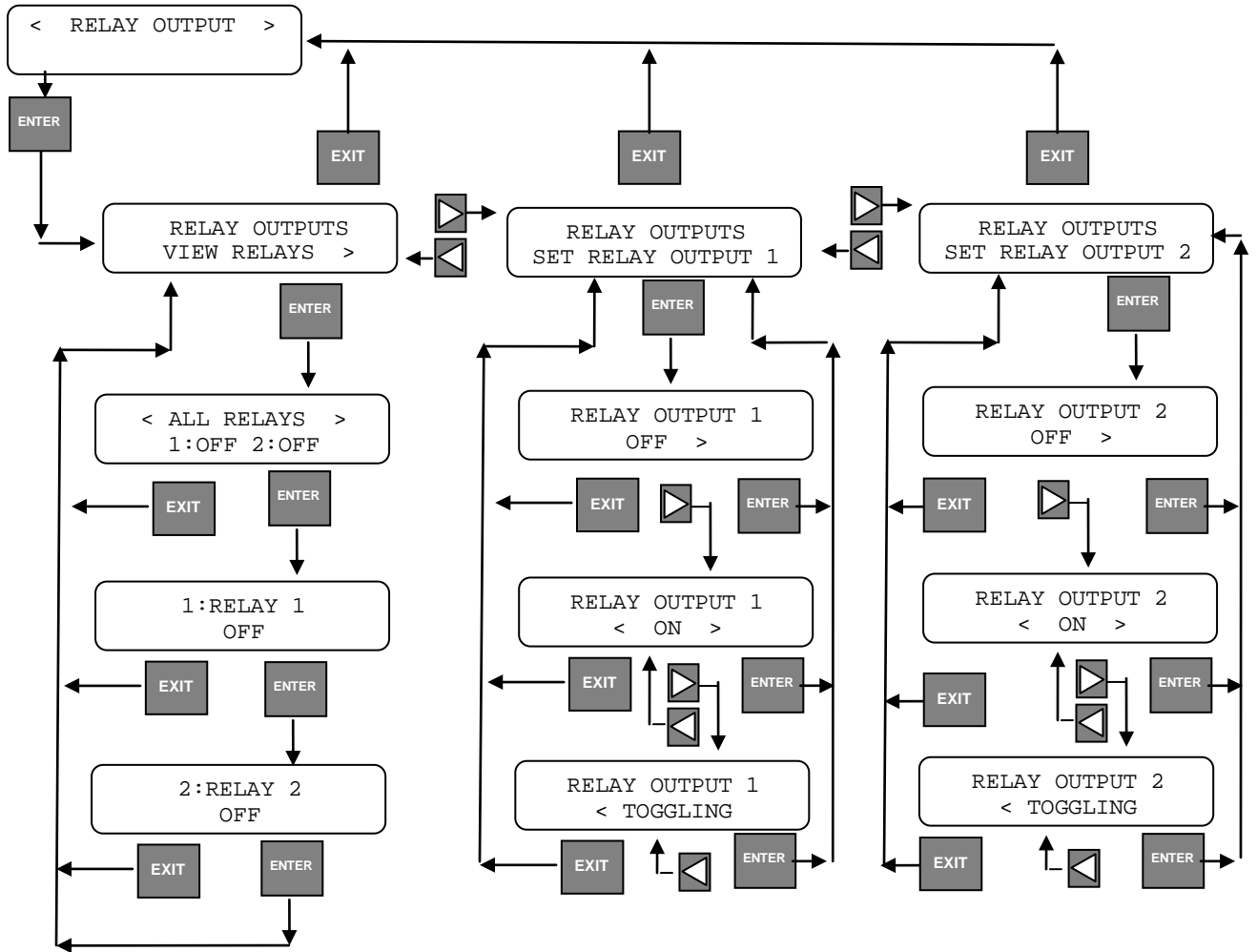

• Monitor I/O – GPS Info

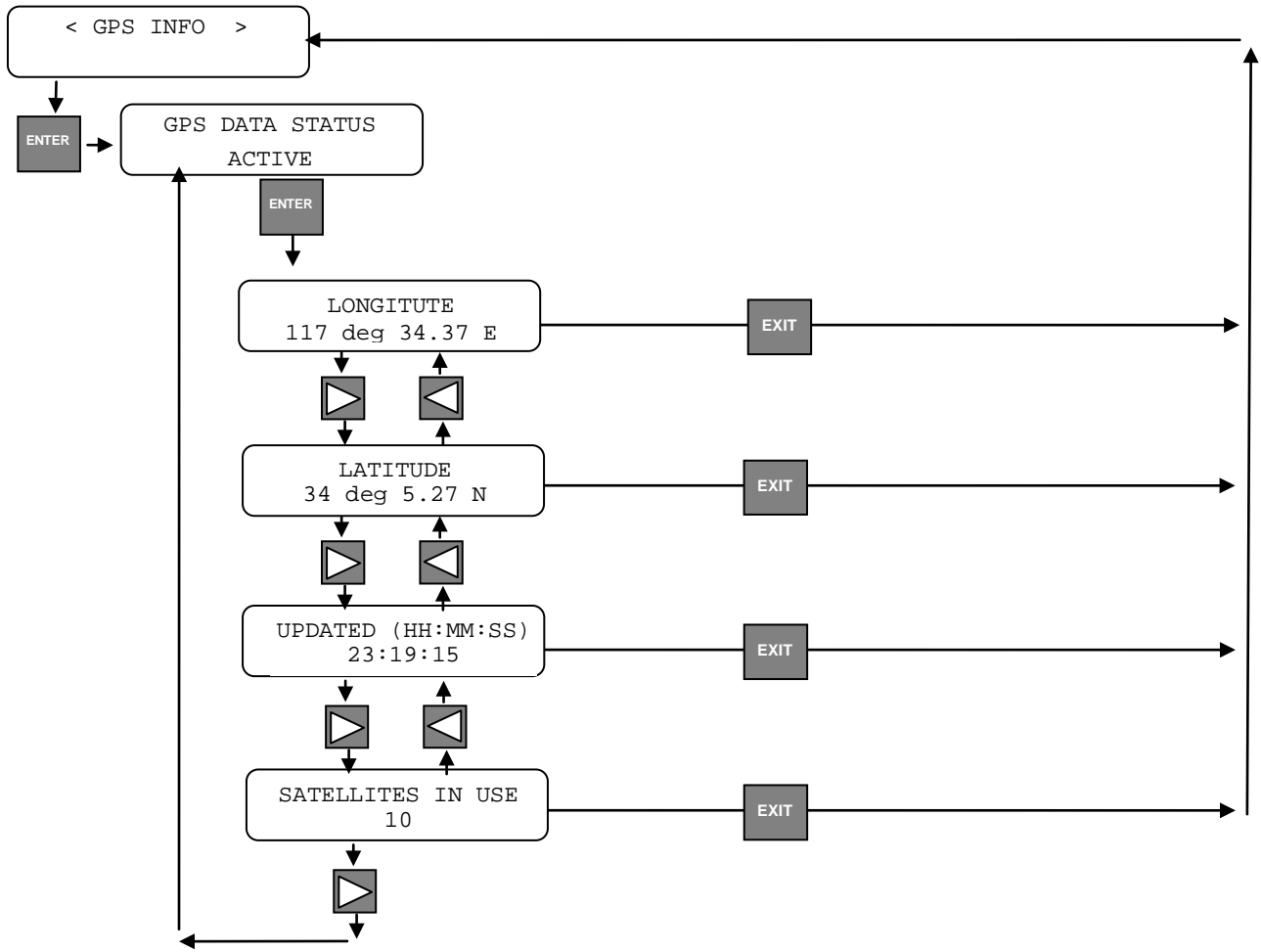

NOTE Communications Manager Model 53475 Revision C3 and newer do not have GPS available.

• Monitor I/O – Modules

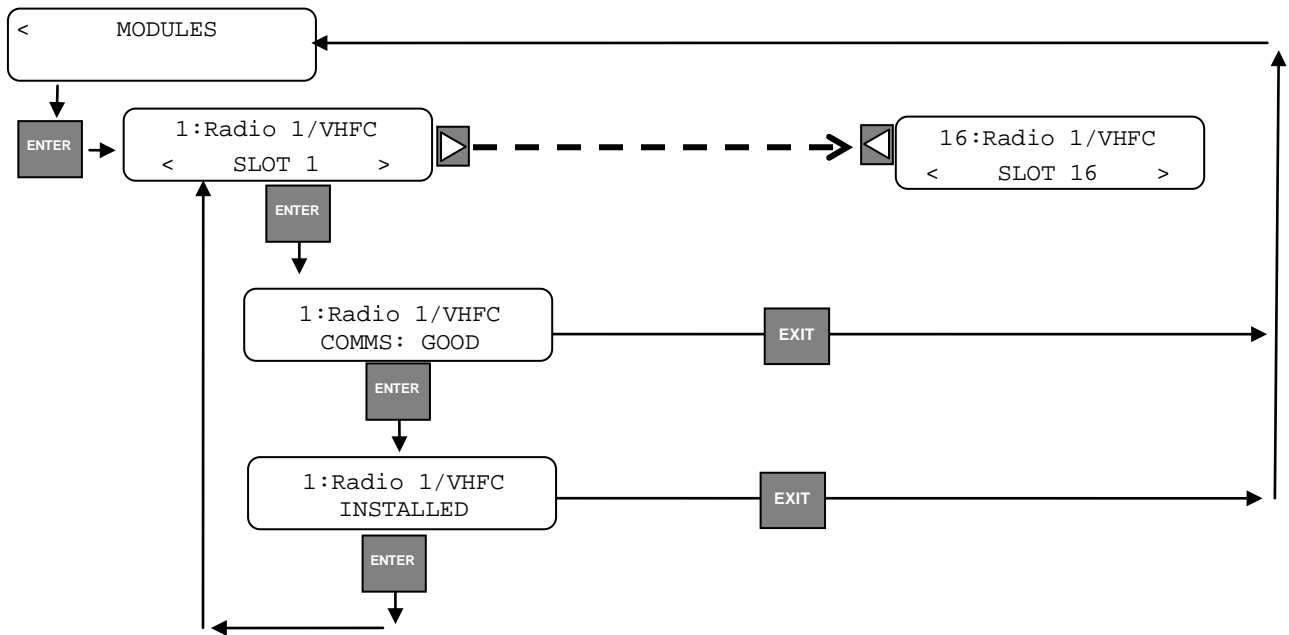

5.3.1.7 Application

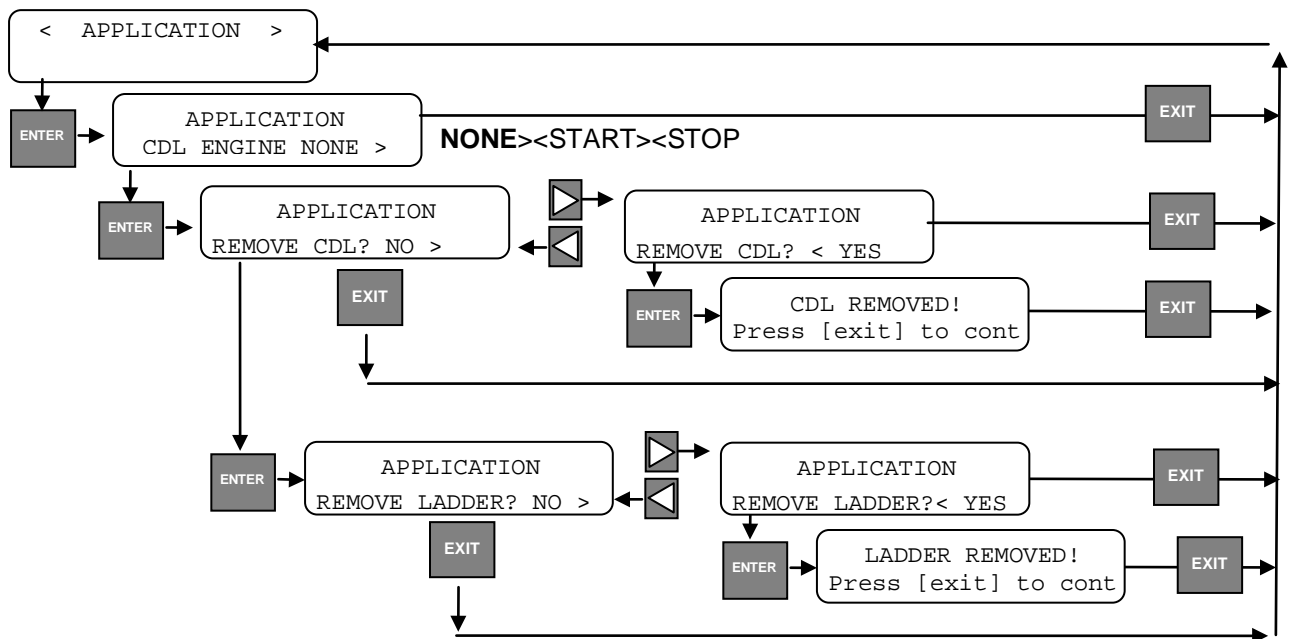

5.3.1.8 WAMS Test

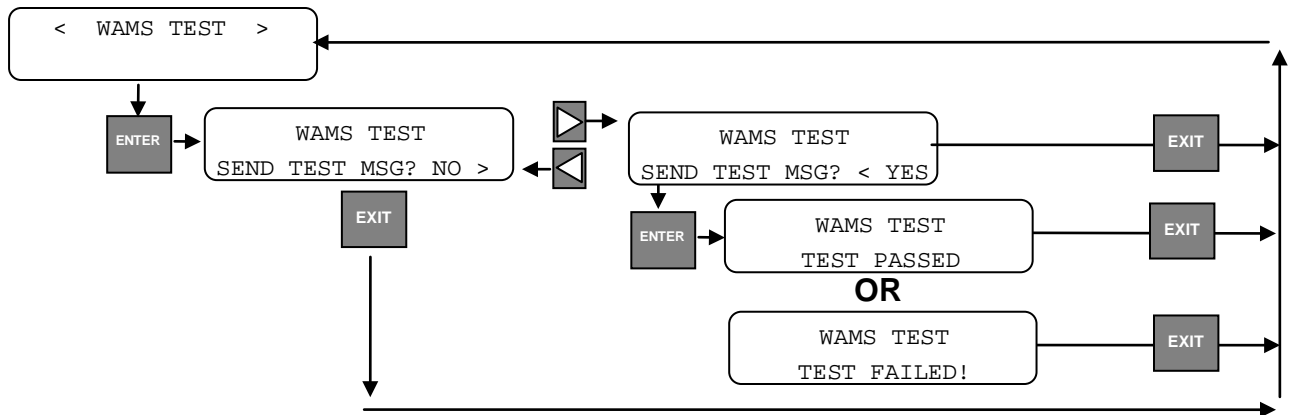

5.3.1.9 Site Setup

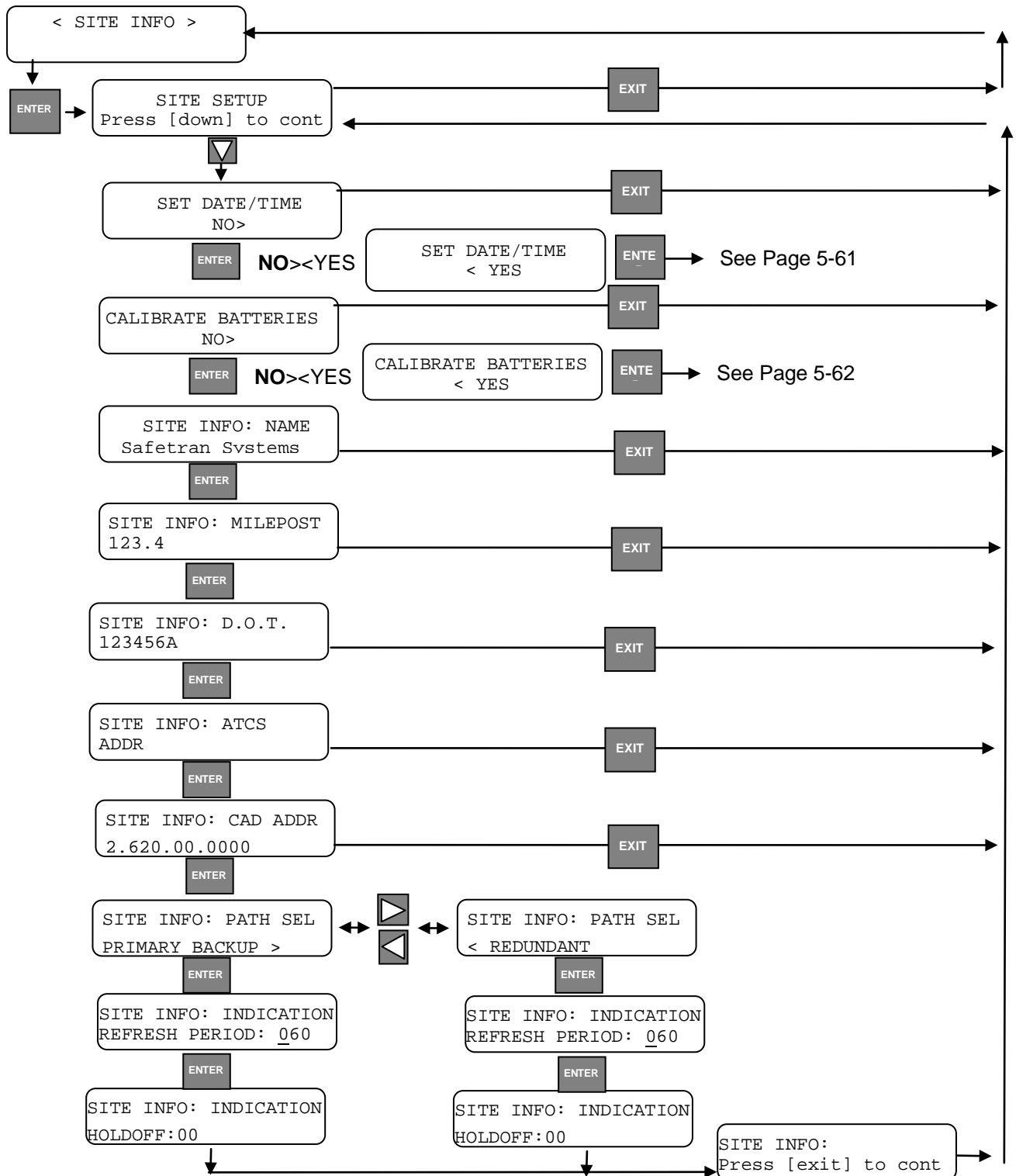

• **Site Setup – Set Date/Time**

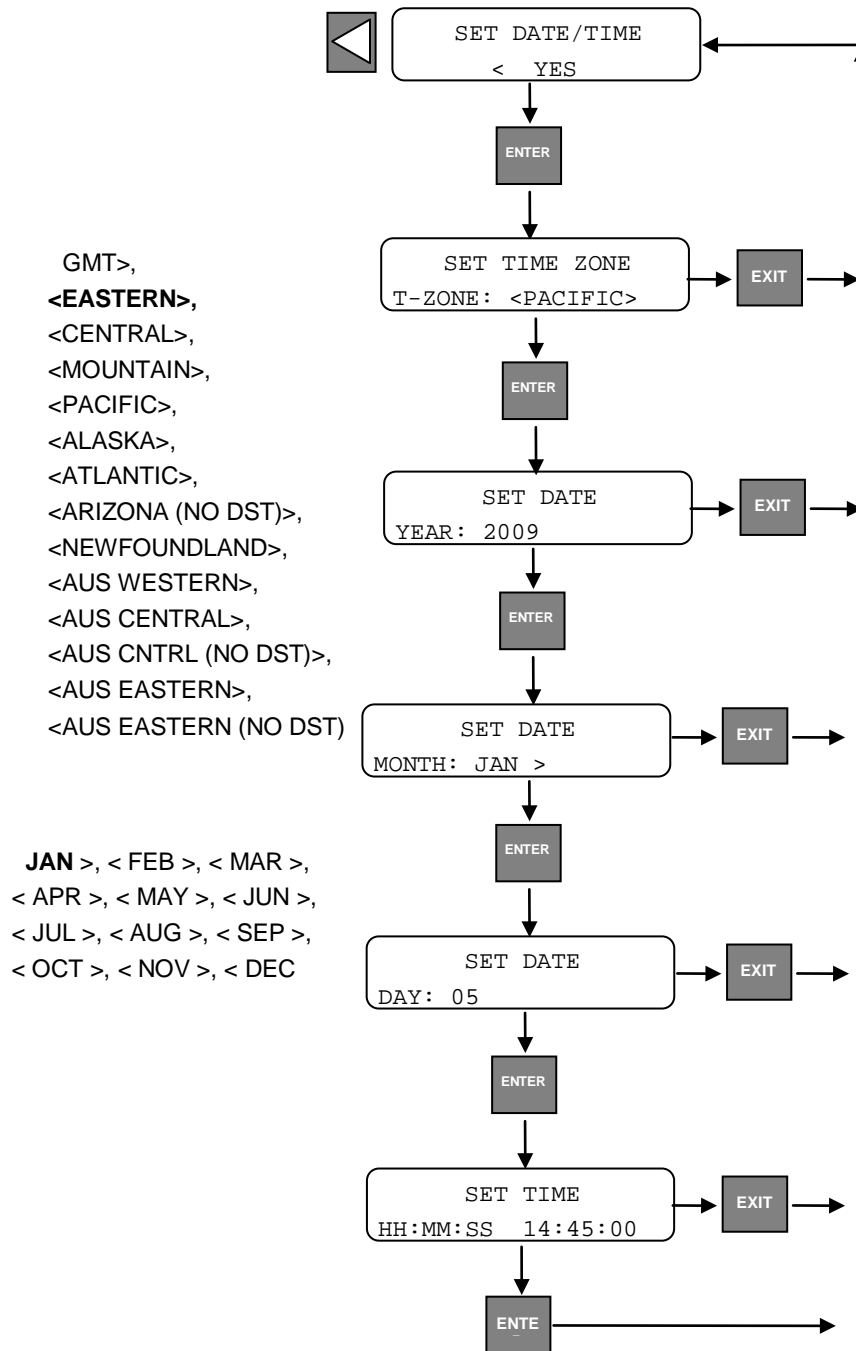

• Site Setup – Battery Calibration

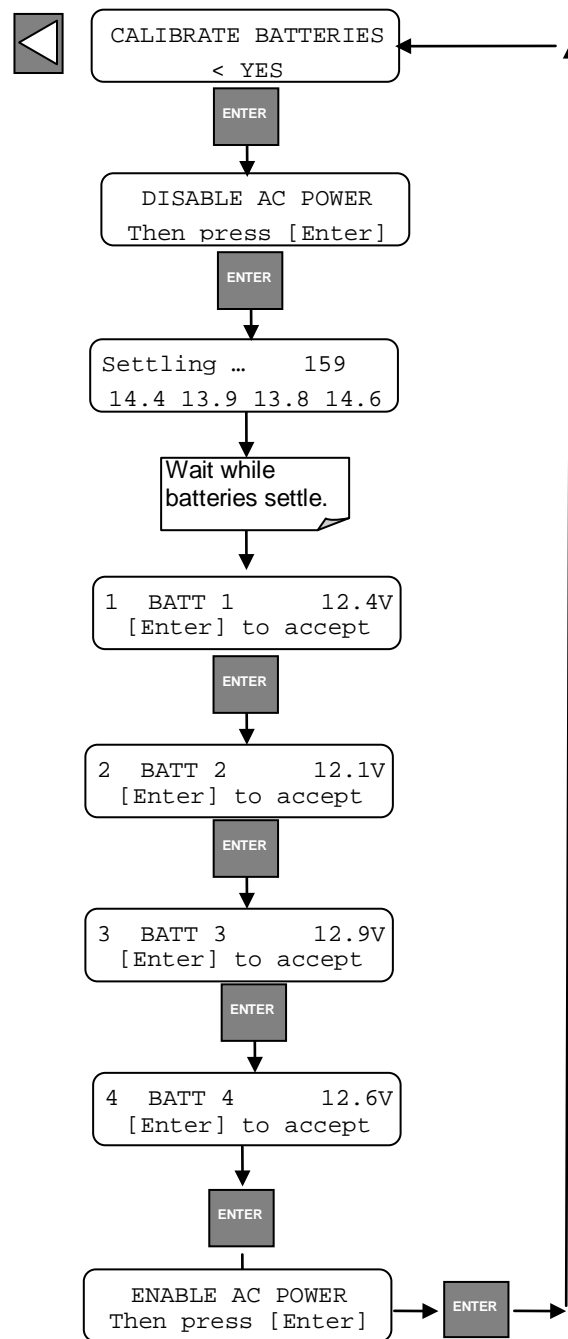

5.3.1.10 System Reset

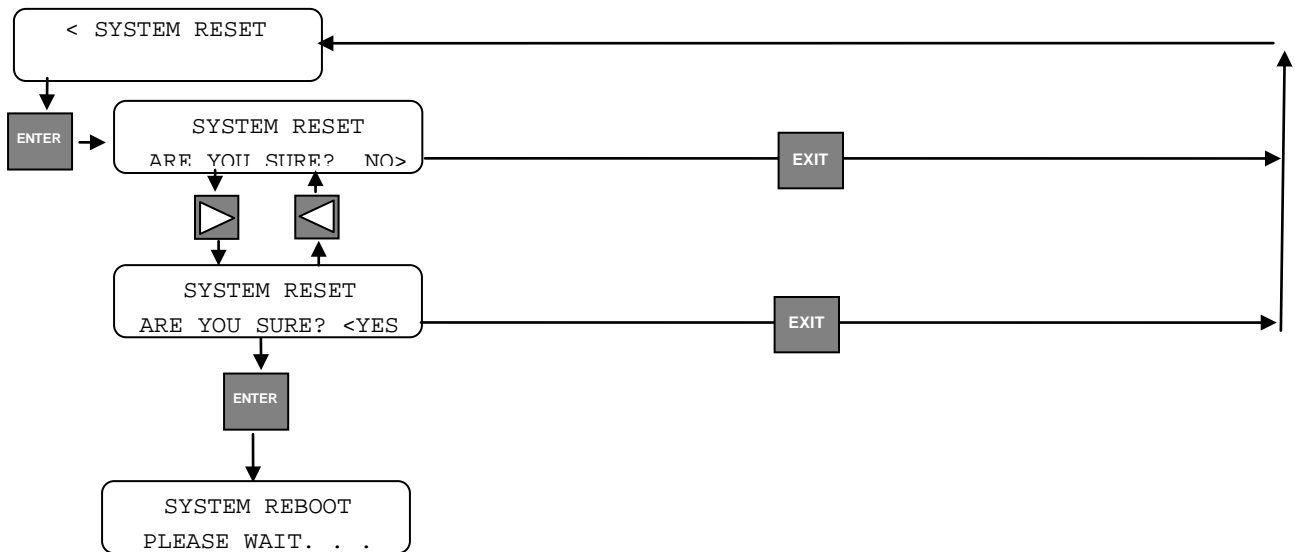

5.3.2 Shortcut Key – Site Setup

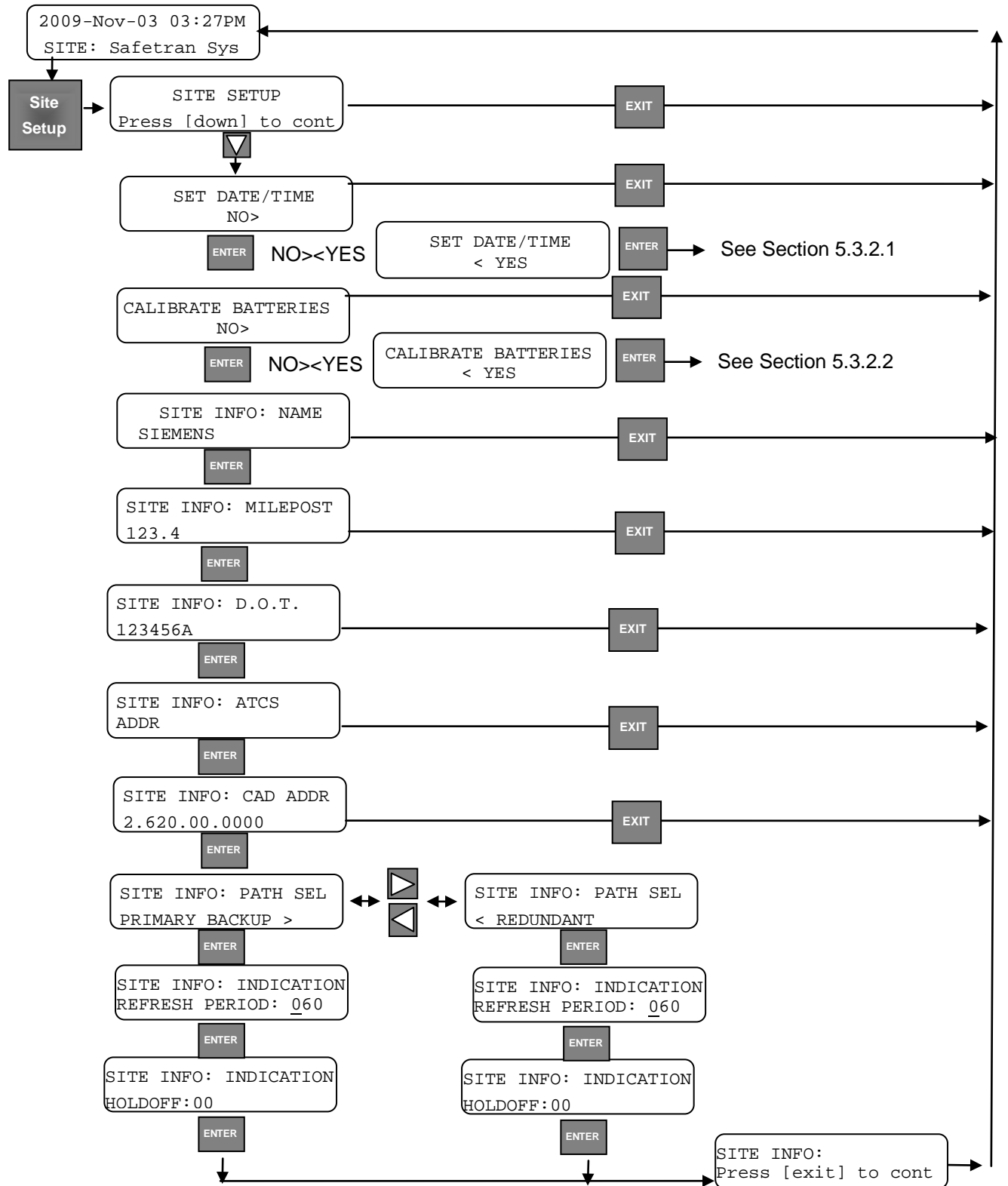

5.3.2.1 Shortcut Key – Site Setup – Set Date/Time

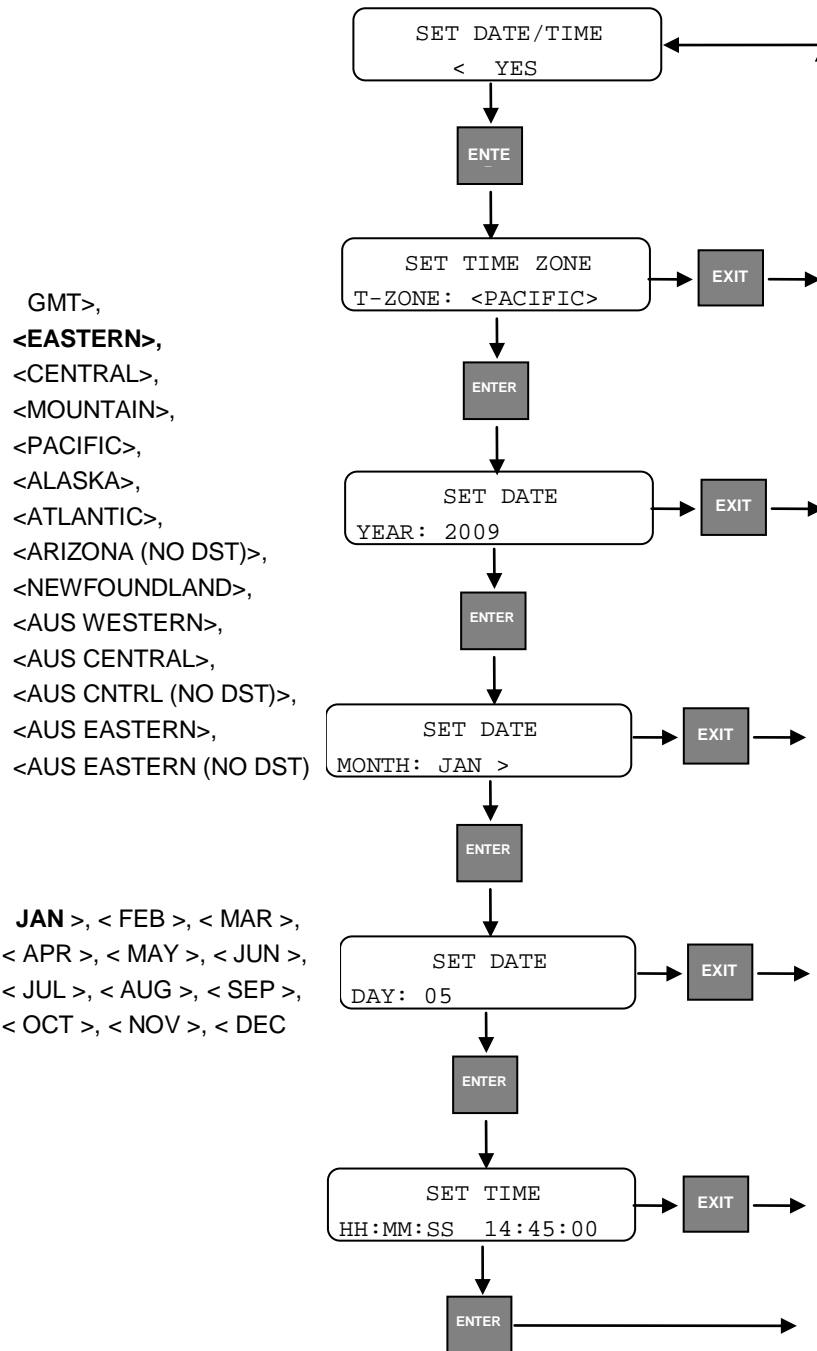

- Site Setup – Battery Calibration

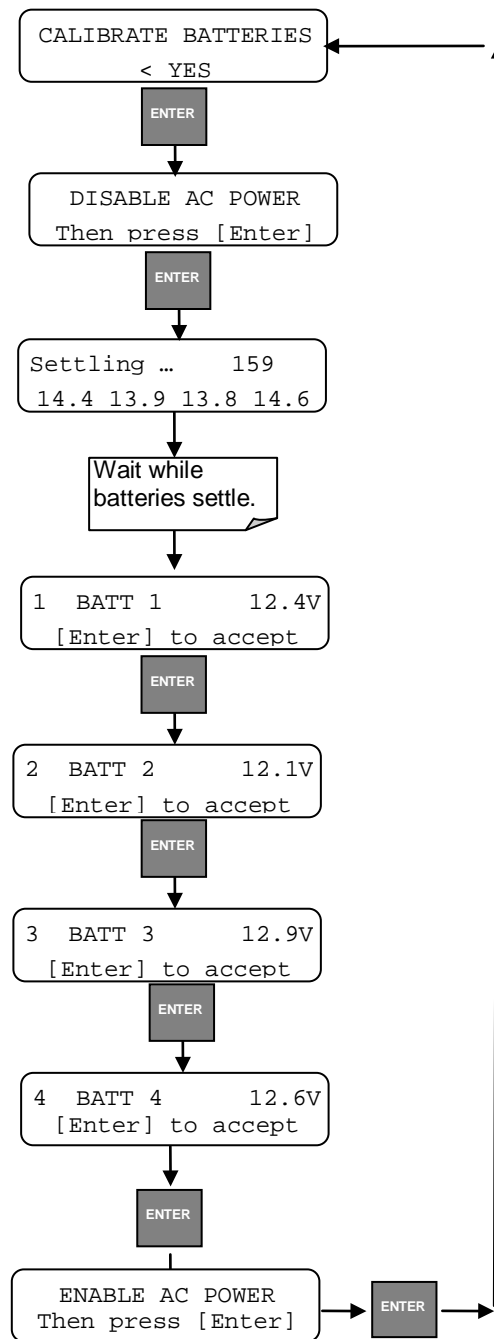

5.3.3 Shortcut Key - Diag

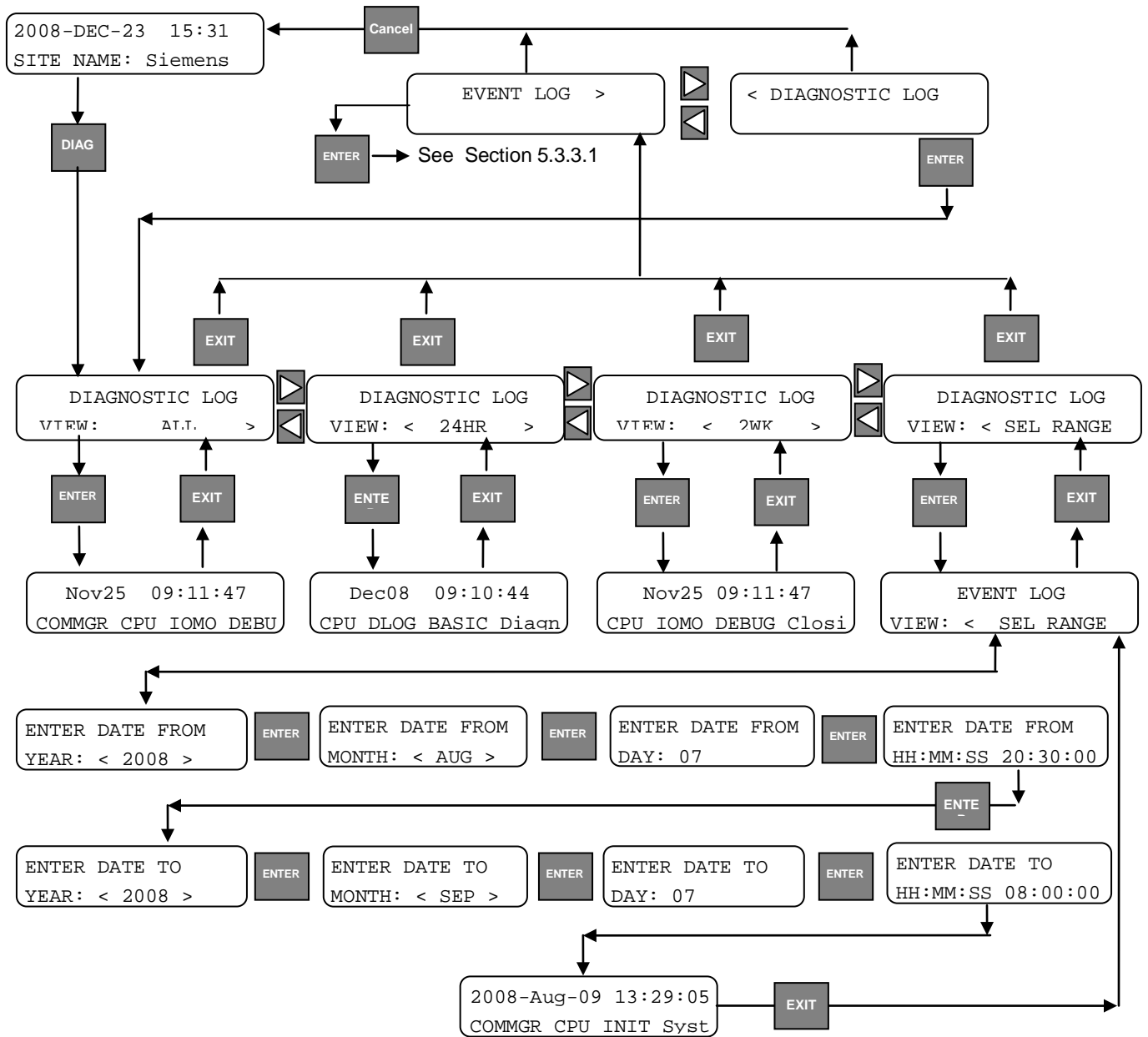

5.3.3.1 Shortcut Key – Diag – Exit to Event Log

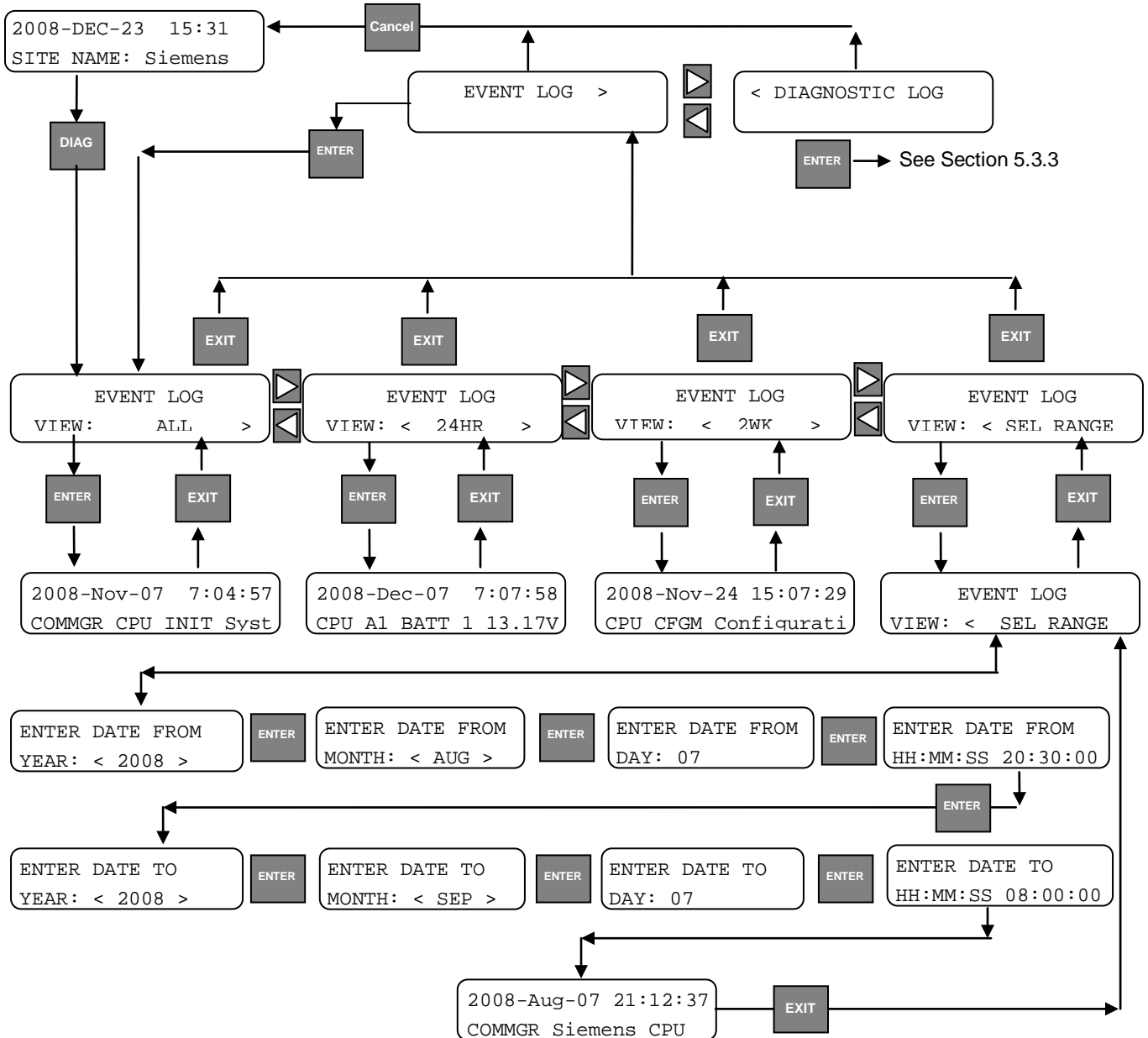

5.3.4 Shortcut Key - Versions

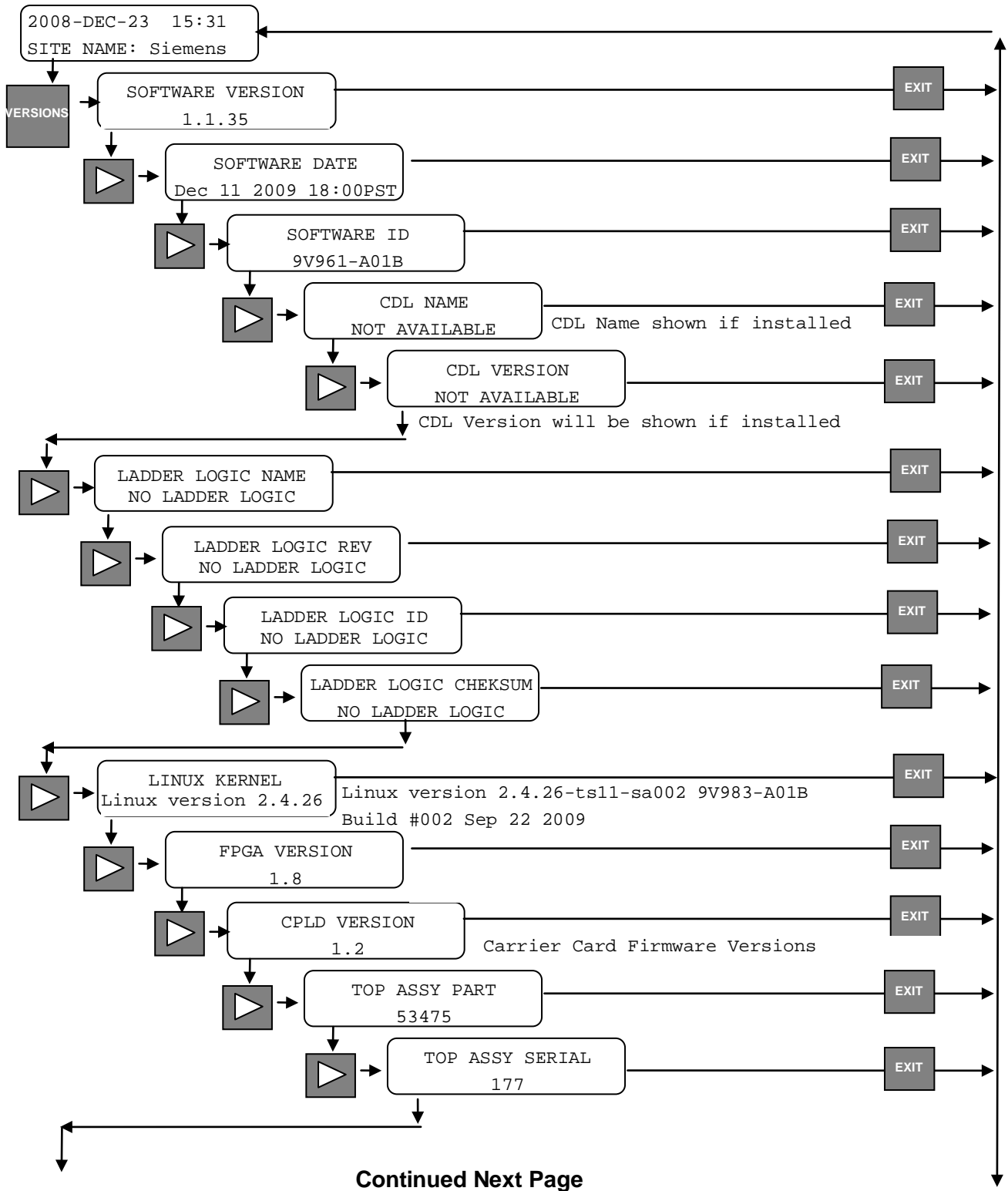

Continued From Previous Page

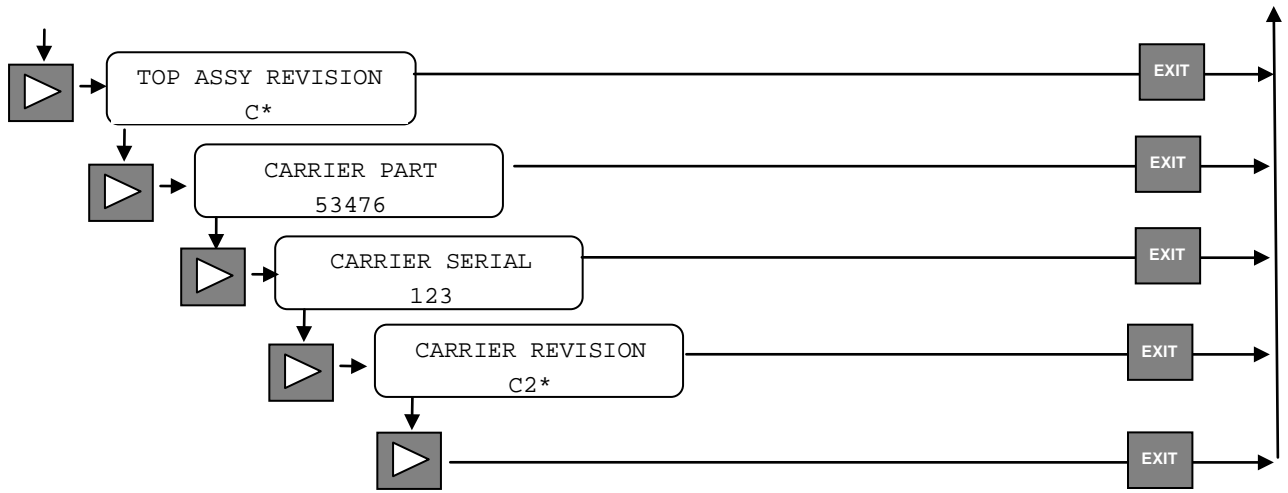

5.3.5 Shortcut Key - Status

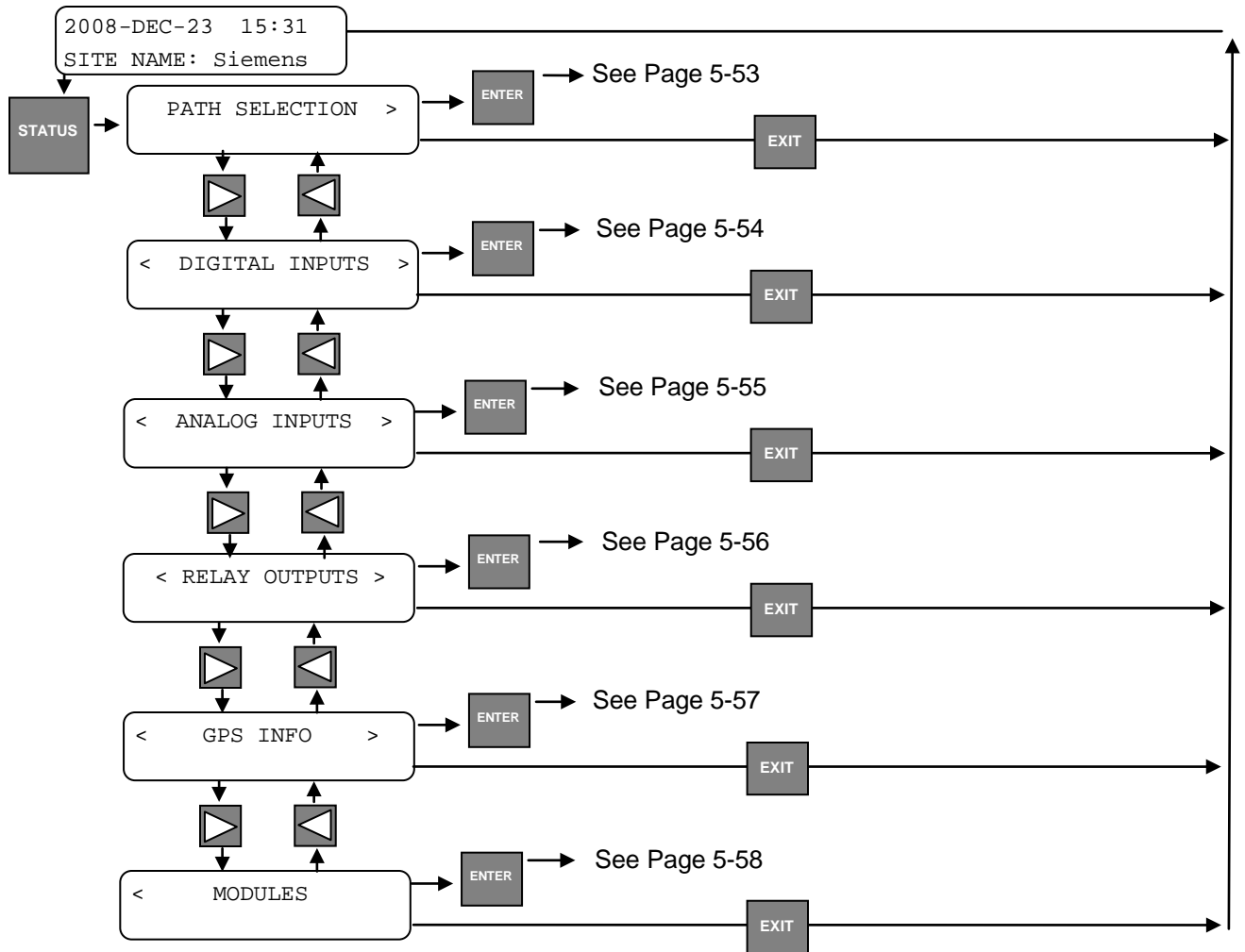

SECTION 6 OPERATION AND MAINTENANCE

6.0 OPERATION AND MAINTENANCE

6.1 GENERAL

The Communications Manager operates transparently once setup and configuration is completed. Monitoring of the Communications Manager is available locally or via the Web UI utility.

6.2 MAINTENANCE

Periodic housekeeping maintenance is advised, to remove dirt and debris on and around the unit. Verify all connections are secure and wiring is not damaged. Keep mating connectors on unused connections to avoid dirt and debris build up.

6.3 USER USB CONNECTOR

The User USB Connector is used to download logs and upload software upgrades and configuration information. Use of a flash memory stick is ideal for this operation, or a computer may be used as well.

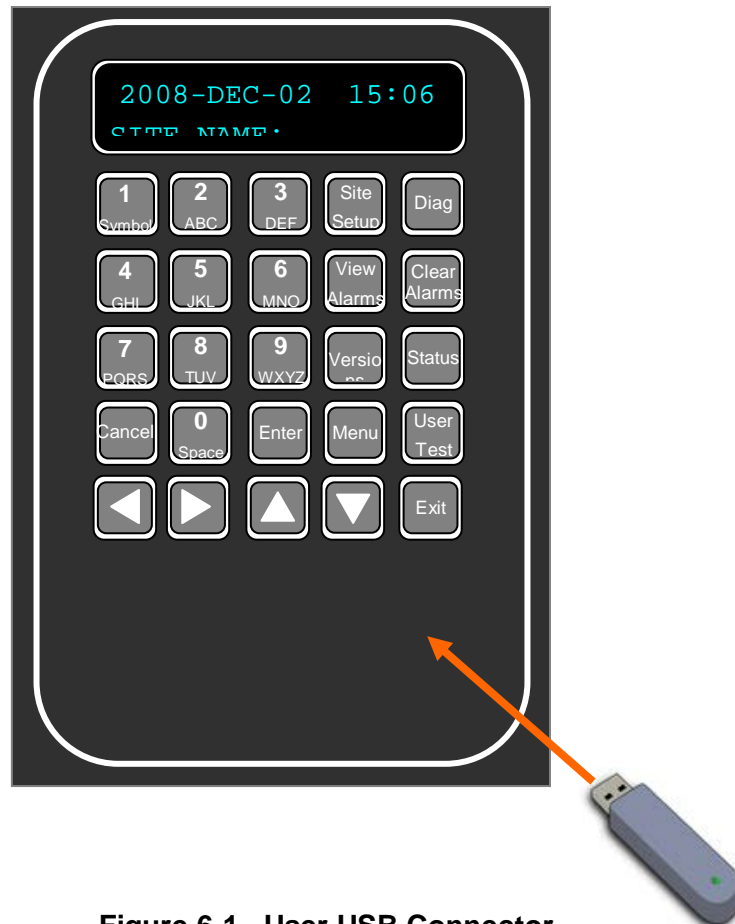

Figure 6-1 User USB Connector

6.3.1 USB Connector Operation

Inserting a USB Flash Memory Stick will automatically activate the USB port. Upon insertion of the USB Stick the green LED will illuminate and the first of a series of interactive messages will appear in the text window as shown in the figure below.

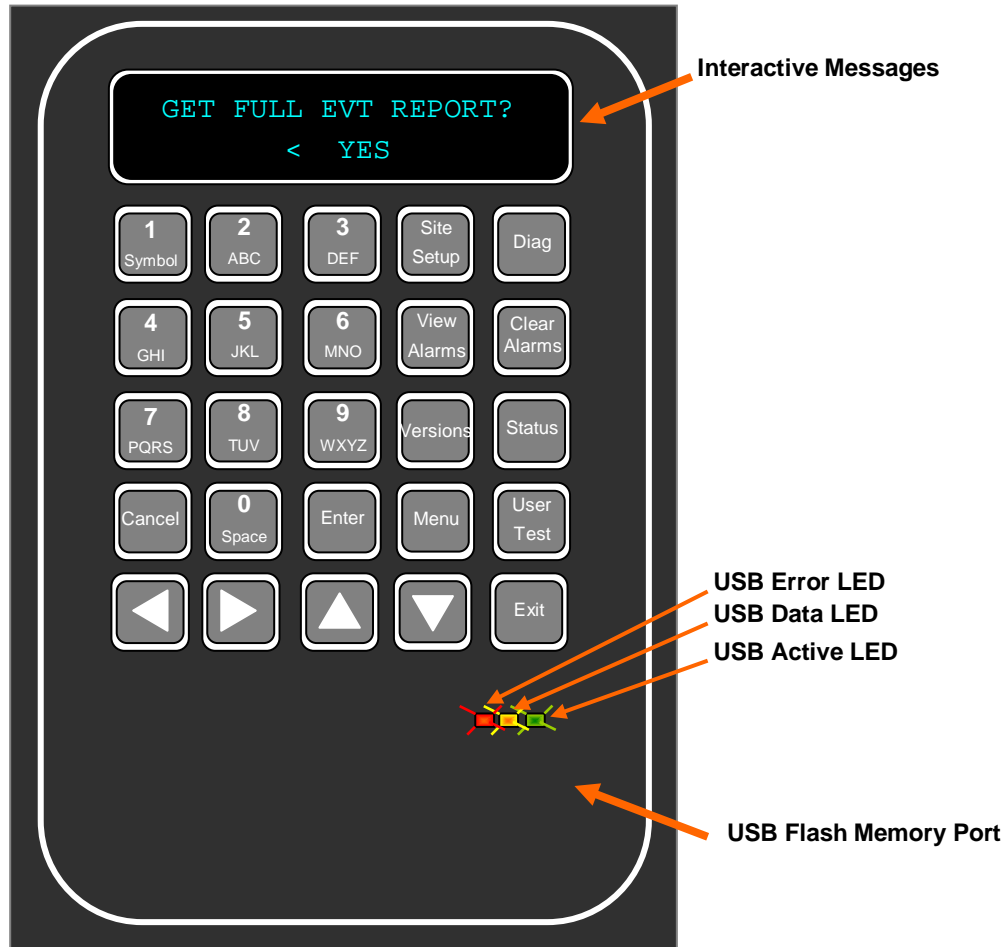
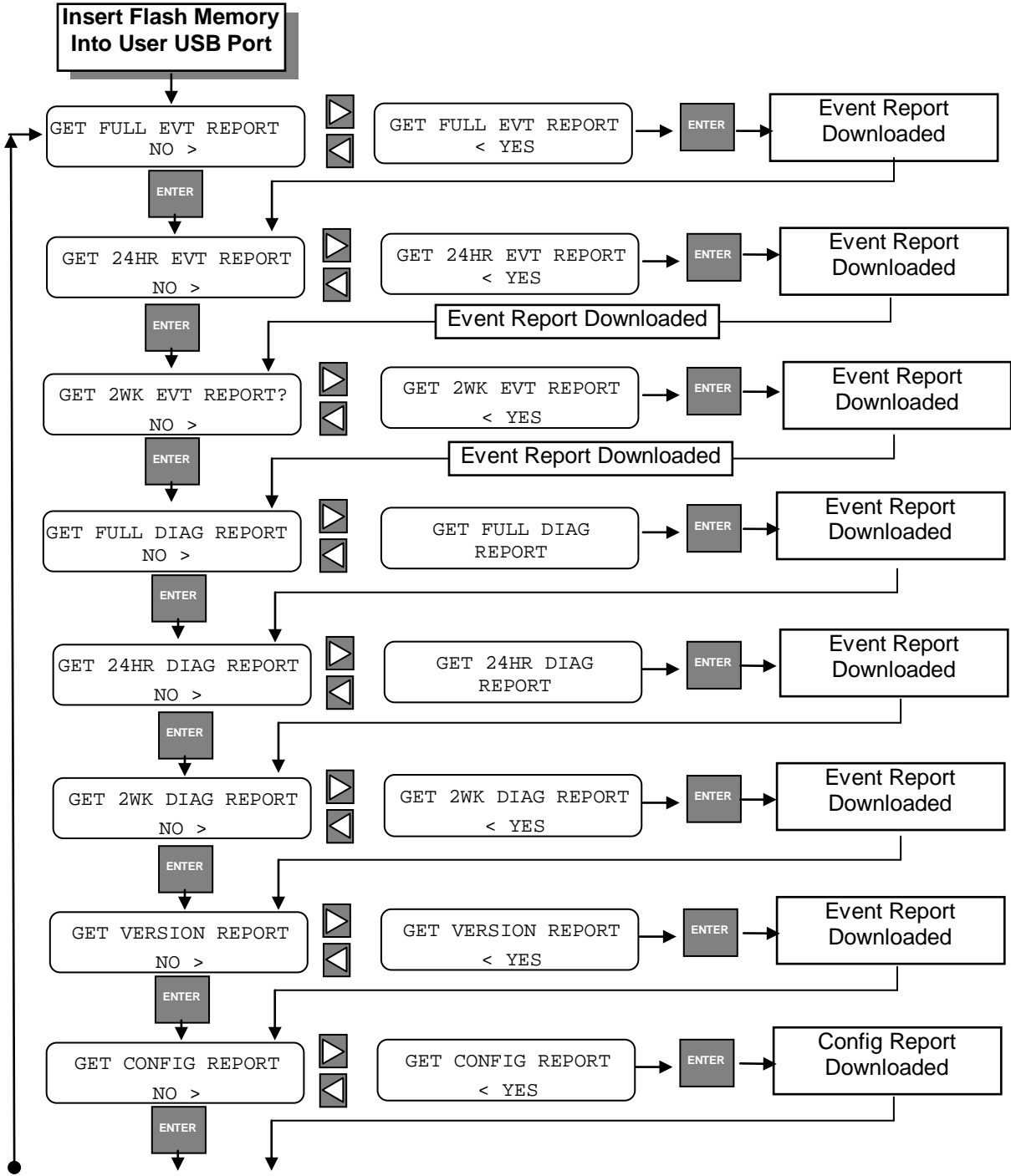

Figure 6-2 USB Connector Operation

6.3.1.1 USB Port Interactive Menus

Inserting the USB Flash Memory Stick will activate a series of interactive menus for downloading reports and configuration data, as well as uploading configuration data and software upgrades. The following figures display the order in which the Menu text appears.



CONTINUED NEXT PAGE

CONTINUED FROM PREVIOUS PAGE

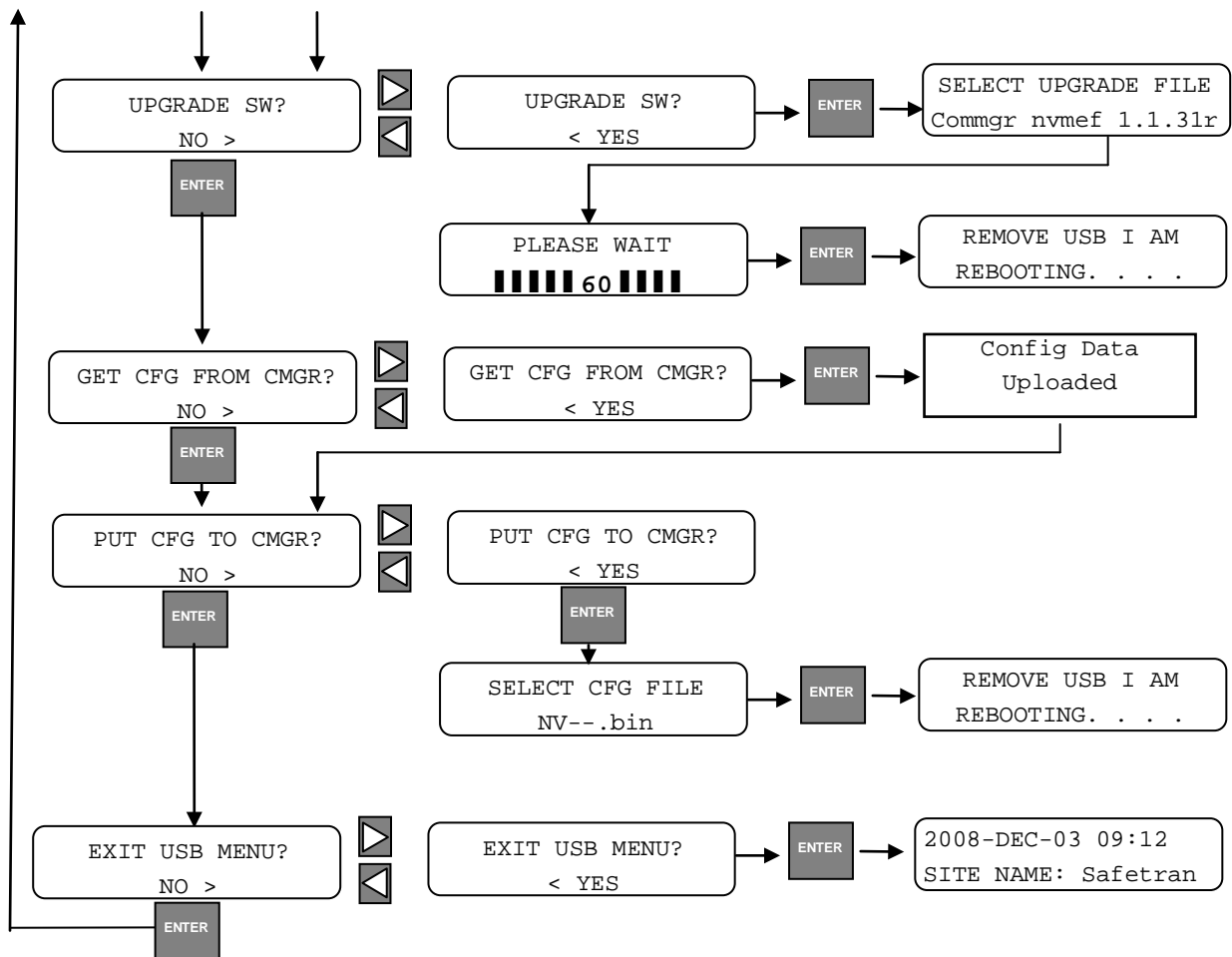

6.4 SOFTWARE UPGRADE

Software upgrades may be installed from a flash drive via the User USB Port. Ensure that the USB drive file structure and file type locations are as indicated below.

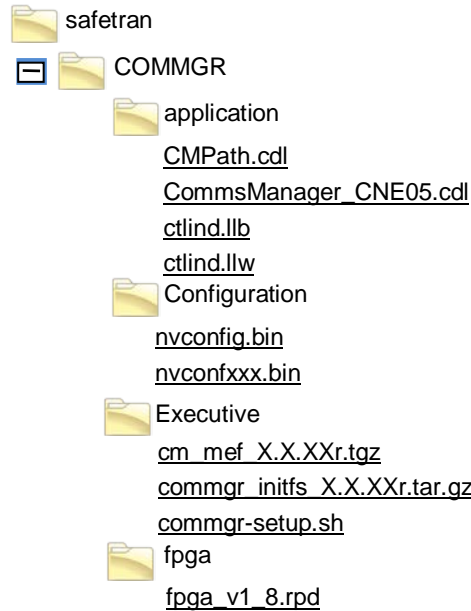

Figure 6-3 USB Drive File Structure

6.5 STATUS INDICATORS

The Communications Manager is equipped with a series of status indicators that provide a visual of system operation as well as input and output status at a glance.

6.5.1 System Status Indicators

The Communications Manager has three System Status Indicators that provide the Health, GPS, and ECD status as shown in Figure 6-4.



Figure 6-4 System Status Indicators

NOTE

NOTE
Communications Manager Model 53475 Revision C3 and newer do not have GPS available.

6.5.1.1 Health Status

Health status of the Communications Manager is provided by the **Health LED**. The Health LED flashes 1 Hz to indicate good health. Bad health is indicated by an indicator flashing rate of 4 Hz.

6.5.1.2 GPS

GPS signal status is provided by the **GPS LED**. A flashing GPS LED indicates satellite signals are being received. GPS information may be viewed using the Local User Interface (LUI) or the Web UI via a web browser. A steady indication occurs when GPS signals are not being received.

NOTE**NOTE**

The GPS feature is no longer available in Communications Manager Model 53475 Revision C3 or later.

6.5.1.3 ECD

The **External Configuration Device (ECD) LED** flashes periodically when data is being sent to or received from the ECD.

6.5.2 Ethernet Ports Status

Each of the four Ethernet Ports has two LED indicators that provide active connection and data transfer status as shown in Figure 6-5. Each port is equipped with a yellow LED indicator that flashes when data is transferred through the port. A green LED represents the connection status of the port. An active connection will illuminate the LED.



Figure 6-5 Ethernet Port Status Indicators

6.5.3 Serial Port Status

Each of the four Serial Ports has LED indicators to provide a visual indication of the operation as displayed in Figure 6-6. Each port is equipped with a data transmit (TX) and receive (RX) LED. Ports 1 and 2 have a third LED to indicate if the port has been configured for RS-422 operation.

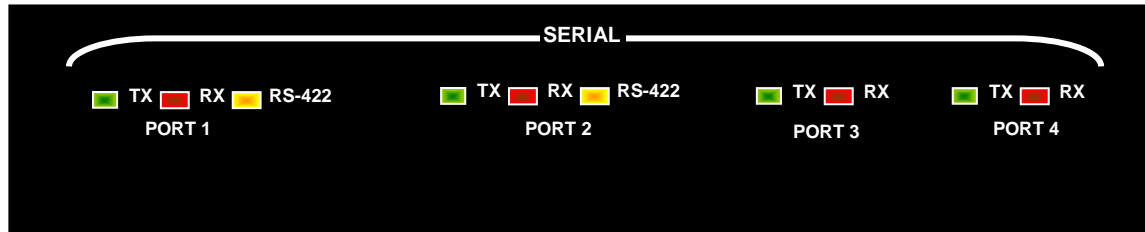

Figure 6-6 Serial Port Status Indicators

6.5.4 Relay / Code Line Output Status

The Relay Outputs have LED indicators to provide the relay output status as shown in Figure 6-7. No indication represents an Open relay output (de-energized state). An illuminated LED indicates the relay output is Closed (energized). A toggling relay output is indicated with a flashing LED. The Relay 2 Output may also be configured for DC Code Line Output. The Code Line LED will illuminate when the Code Line is active. Relay Output LEDs may be controlled by a CDL program. Refer to the CDL reference manual for details.

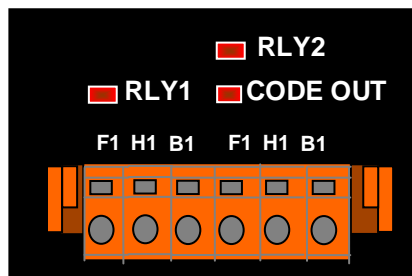

Figure 6-7 Relay / Code Line Output Status

6.5.5 Analog Inputs/Code Line Input

There are four Analog Inputs available on the Communications Manager, with the fourth input capable of being configured as a DC Code Line Input. Active inputs will illuminate the yellow Status LED as shown in Figure 6-8 below. Analog Input LEDs may be controlled by a CDL program. Refer to the CDL reference manual for details.

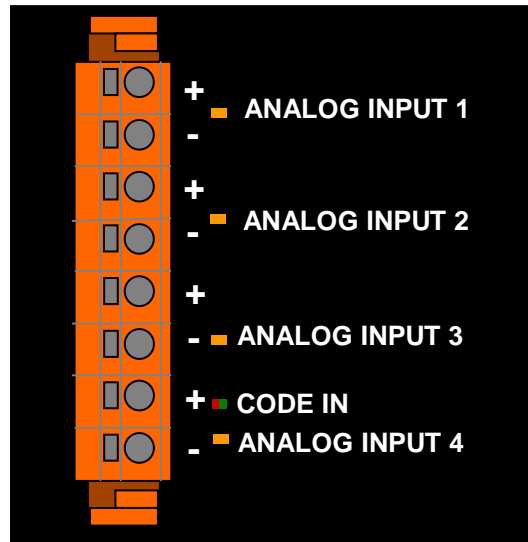

Figure 6-8 Analog Inputs / DC Code Line Input Status

6.5.6 User Defined Status

The Communications Manager is equipped with 16 User Status Indicators, displayed in Figure 6-9, that may be configured via the CDL software. These indicators may be configured to indicate device status, alarms, etc. A label area is provided adjacent the indicators for local identification of the device or condition being monitored.

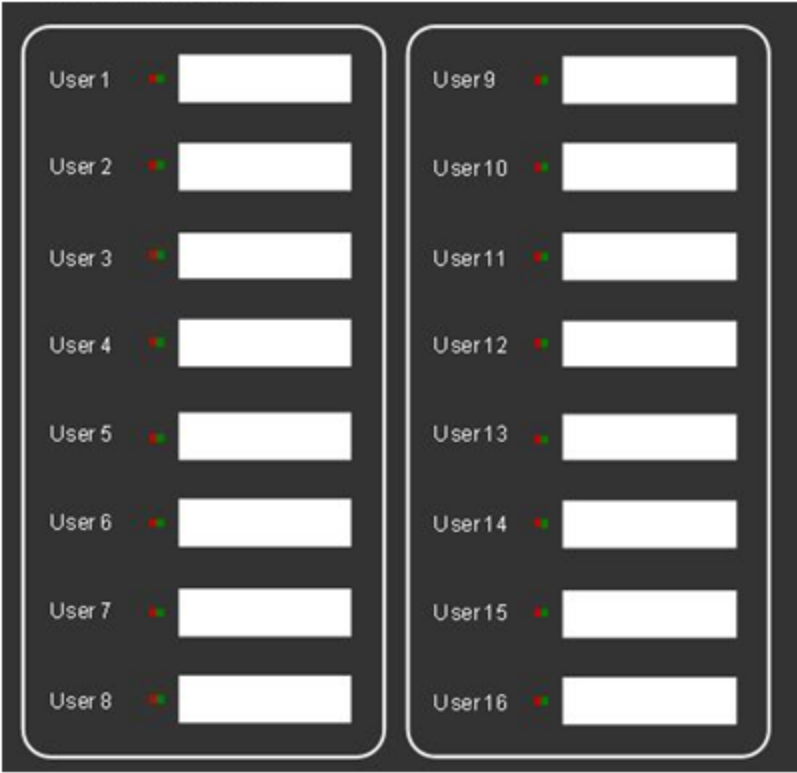

Figure 6-9 User Defined Status Indicator

6.5.7 Digital Input Status

The eight Digital Inputs are equipped with LEDs to indicate input activity, as shown in Figure 6-10. A label area adjacent to the status LED is available for local identification of the input source. Digital Input LEDs may be controlled by a CDL program. Refer to the CDL reference manual for details.

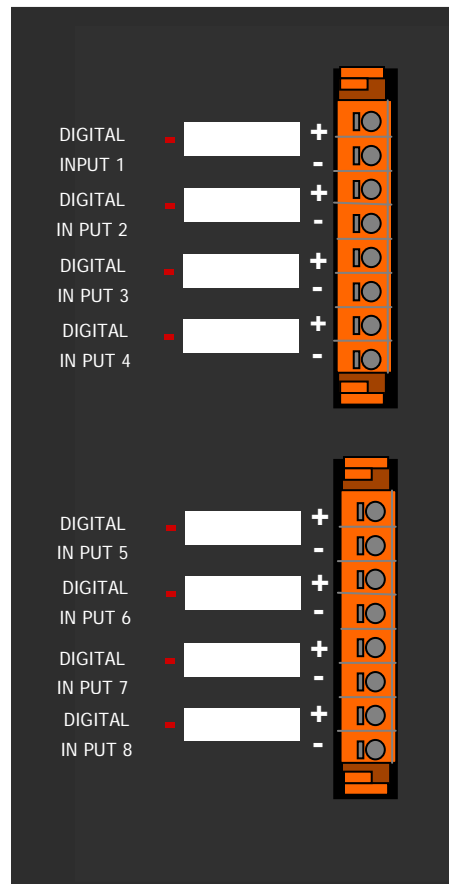

Figure 6-10 Digital Input Status and Identification

6.5.8 Isolated Power Supply / Echelon®

The Communications Manager is equipped with a 12 VDC, 3 Ampere Isolated Power Supply Output for use with non-vital equipment. A red LED illuminates when the power supply output is enabled via software control. The default setting enables the output. An Echelon® connection provided for interfacing with Echelon® Lon-Talk® network equipped devices. The Echelon® connection is a non-polarized twisted-pair. A dual color (Green/Yellow) LED indicates connection and data transfer.

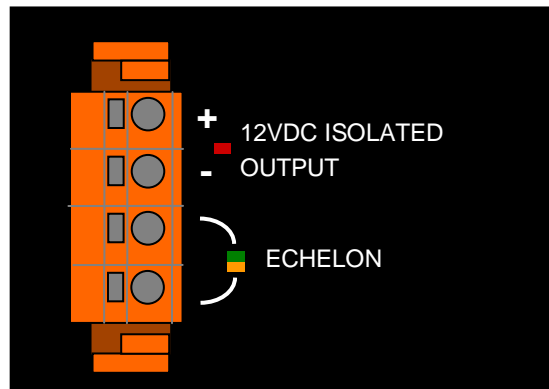

Figure 6-11 12 VDC Isolated Power Supply / Echelon®

This Page Intentionally Left Blank

SECTION 7 TROUBLESHOOTING

7.0 TROUBLESHOOTING

7.1 GENERAL

Operation of the Communications Manager in most cases will be transparent. If a problem arises, the following table may be used for troubleshooting. Any questions may be directed to Siemens Customer Service.

Table 7-1 Troubleshooting Chart

Problem	Possible Causes	Corrective Action
Green Power LED not illuminated.	No power to the Communications Manager	Check power supply input and polarity.
12 VDC Isolated Power Supply LED is not illuminated.	An over current situation has occurred.	Clear the over current and reset the Communications Manager.
12 VDC Isolated Power Supply Output Voltage is below 12 VDC.	Excessive Load or Short Circuit	Remove load and check output voltage. If 12 VDC returns verify load is under 3A.
Ethernet Port inoperative.	Parameters not properly set.	Check port settings.
Serial Port inoperative.	Parameters not properly set.	Check port settings.
No GPS information available.	No satellite signal available.	Check GPS Antenna installation.
USB Error LED illuminates when attaching Flash Drive.	Flash Drive corrupted or inoperative.	Use a different USB Flash Drive.
Site ATCS Address changes when Communications Manager restarts.	When VHLC code unit performs XID operation with Communications Manager, if the ATCS provided in XID message is different than the current Site ATCS address, the current Site ATCS Address is overwritten with that contained in the XID message.	This is normal behavior.

Table 7-1 Troubleshooting Chart (Continued)

Genisys Office polling stops	When Communications Manager receives an indication from a Genisys code unit, indication is sent to the office. Then, Communications Manager suspends polling until office replies with an RF acknowledge, Communications Manager resumes polling. On the other hand, if after 60 seconds, no RF acknowledgement is received, poll automatically resumes.	This is normal behavior.
------------------------------	--	--------------------------

7.2 REPLACING COMMUNICATIONS MANAGER UNIT

Replacing a Communications Manager unit is a quick and simple procedure. The following procedure details exchanging a Communications Manager unit:

1. Verify connected equipment is shutdown and secured to enable disconnection from Communications Manager.
2. Mark connector locations and remove all connectors as shown in Figure 7-1.

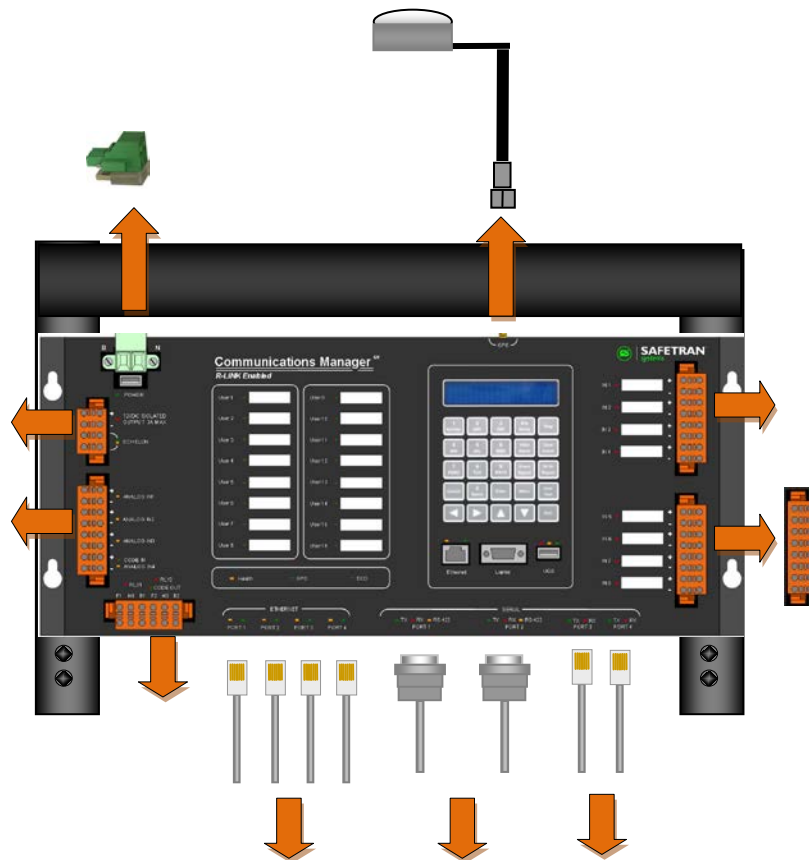

Figure 7-1 Uninstall Communications Manager – Unplug Connectors

3. Remove unit to be exchanged and install new unit as shown in Figure 7-2 .

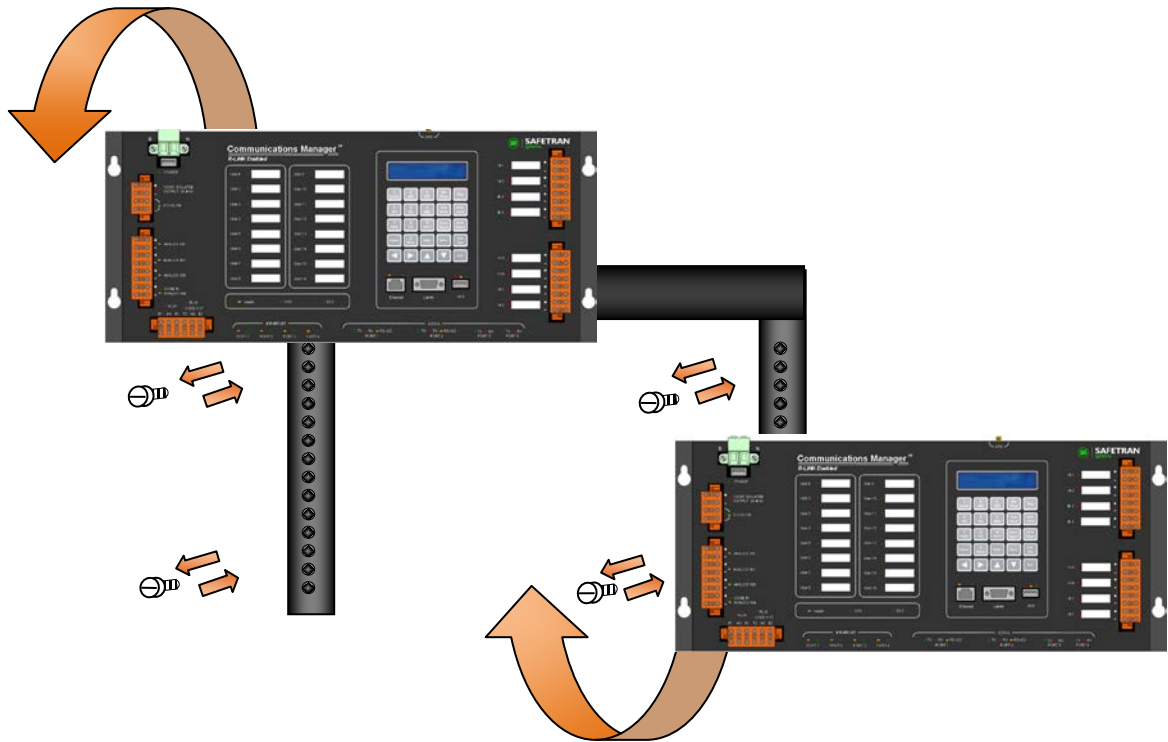

Figure 7-2 Uninstall Communications Manager – Remove and Replace Unit

4. Install GPS antenna cable as shown in Figure 7-3
5. Install Power/ECD connector as shown in Figure 7-3 (**do not connect any external equipment at this time**) and allow Communications Manager to boot up.

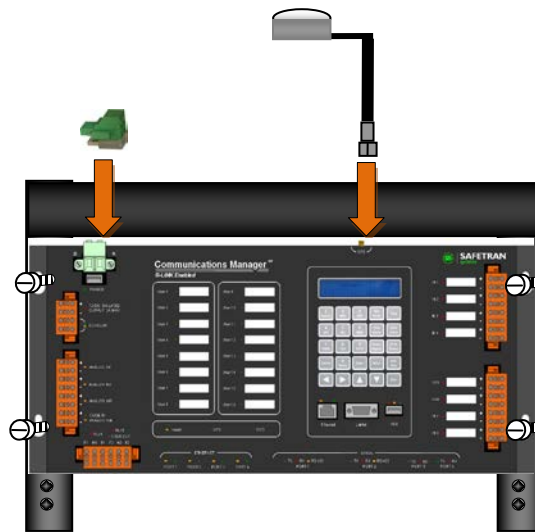

Figure 7-3 Re-install Communications Manager – Connect Power and GPS

6. Verify using Keypad and display (LUI) Site configuration information has been transferred to the replacement unit. Note: Configuration information is stored in the ECD and automatically is loaded at unit start up.
7. Once Communications Manager's operation and configuration are verified, power down Communications Manager and insert the peripheral equipment connectors taking care to return connectors to their proper location.

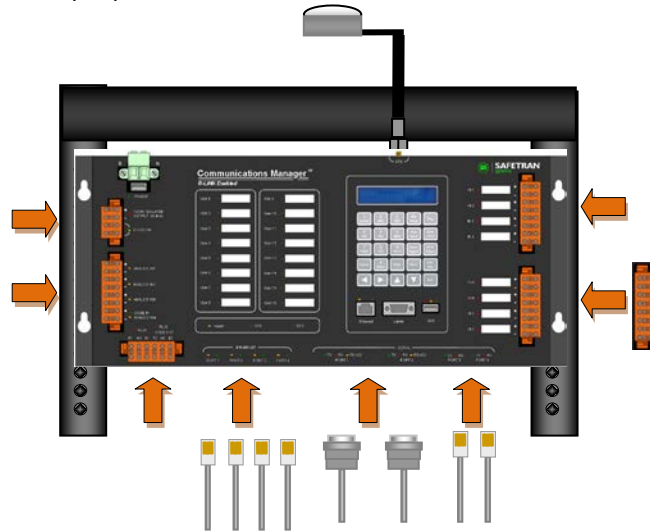

Figure 7-4 Re-install Communications Manager – Re-connect Peripheral Equipment

8. Power up Communications Manager and perform necessary tests to verify system is operating properly.



Figure 7-5 Re-install Communications Manager – Returning System On-Line

This Page Intentionally Left Blank