

Installation Instructions

	DANGER
	Hazardous voltage. Will cause death or severe injury. Turn OFF and lock out all power supplying the HCP switch before installing accessory. Replace all barriers and fuses and close door before turning power ON.

	SAFETY INSTRUCTIONS
---	----------------------------

These instructions outline the recommended installation procedure.

FOR USE WITH HCP SENTRON™ SWITCH

1. Switch Preparation

- A. Turn off and lock out all power to this device before installing accessory.
- B. Open door and trip the switch before installing shunt trip assembly.
- C. To trip mechanism, strike latch link with a tool (See Figure 1), keeping hands and tools clear of mechanism.

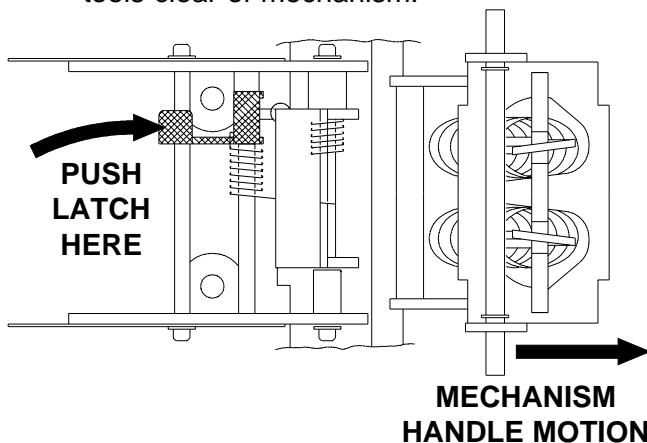

Figure 1. Switch Mechanism

2. Accessory Mounting Instructions

- A. For ease of installation, engage latch, with mechanism handle in tripped position.
- B. Remove A phase fuse if installed.
- C. Pull barrier back as shown in Figure 2 to expose shunt trip mounting holes.
- D. Nest shunt trip accessory inside of left mechanism frame, press down firmly on top of accessory and secure with two 10-32 screws provided. Torque to 28 - 30 lb.-in.
- E. Switch actuator of accessory must be under latch link after installation.
- F. Rotate latch to proper position so latch link engages and depress solenoid plunger to verify proper travel. Plunger will release latch.
- G. Move barrier back into position.

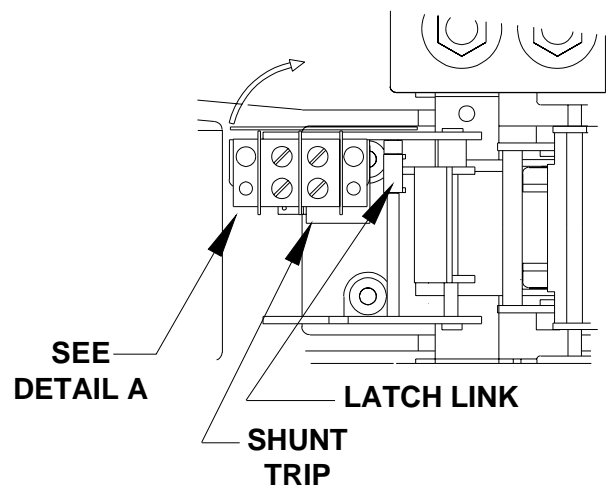
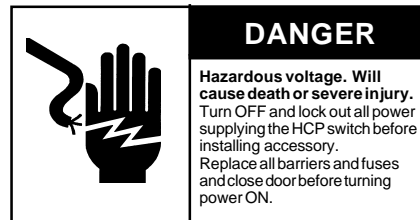
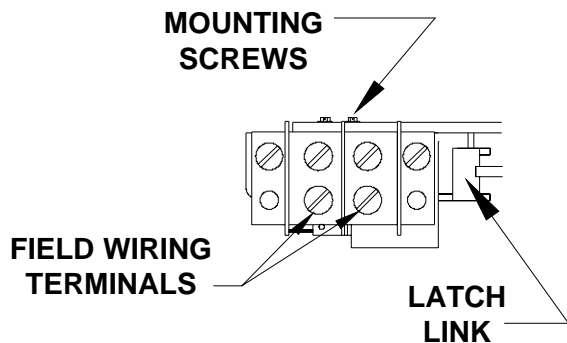

Figure 2. Shunt Trip Installation



Installation Instructions



Detail A. Terminal Block

3. Wiring Information

- A. Attach the field wiring to the appropriate terminals as shown in Detail A.
- B. The Binding Head screw terminals will accept No. 12 to No. 18 AWG wire (Cu only) or insulated crimp type connectors. Strip wire insulation 3/8" maximum.
- C. Torque the terminal screws to 8 - 10 lb.-in.
- D. Unlatch latch by pushing with a hand tool.
- E. Replace A phase fuse if removed and torque mounting nuts to 40 -42 lb.-ft.
- F. Check to ensure line shield is secure and close cover before turning on power to this device.

4. Mechanical / Electrical Testing

- Note: This shunt trip accessory is equipped with an internal clearing switch.
- A. Close door to unit and rotate handle to "RESET" and then "ON" position. Use the voidable door interlock feature to open the door in the "ON" position.
 - B. Connect a buzzer or light indicator across terminals 2 and 3.
 - C. The buzzer or light indicator should indicate "continuity."

- D. If a minimum of 55% of the rated voltage is applied across the field wiring terminals, the shunt trip accessory will trip the switch.
- E. Remove power from the field wiring terminals and check continuity to ensure that the clearing switch is functioning properly.

5. Electrical Data

Table 1 - Shunt Trip Coil Data

CATALOG NO.	Coil Voltage	Inrush Current at Rated Voltage (AMPS RMS)
HCPST120	120VAC	8.5
HCPST240	240VAC	4.5
HCPST277	277VAC	4.5
HCPST480	480VAC	3.0
HCPST24	24VDC	18.0
HCPST48	48VDC	9.0
HCPST125	125VDC	5.0

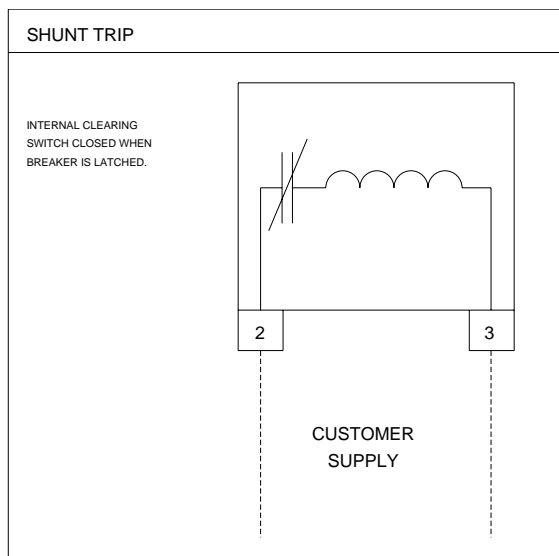

Figure 3. Connection Diagram