

General Motion Control Product Portfolio Overview

SINAMICS
Low Voltage Converters

Index



Siemens Organization



Providing technology solutions to address the greatest challenges of our time

Healthcare system

Aging society
 Personalized healthcare
 Affordable healthcare

Population growth
 Increase in chronic diseases

Digital transformation of industry, infrastructure and mobility

Competitive industries
 Productivity

Efficient infrastructure
 Sustainable use of resources

Economic growth
 Prosperity

Energy transition

Distributed energy systems / Grid edge
 Reliable supply

Increasing demand
 Climate change / decarbonization

Energy efficiency
 Hydrogen / sector coupling

Energy backbone for society

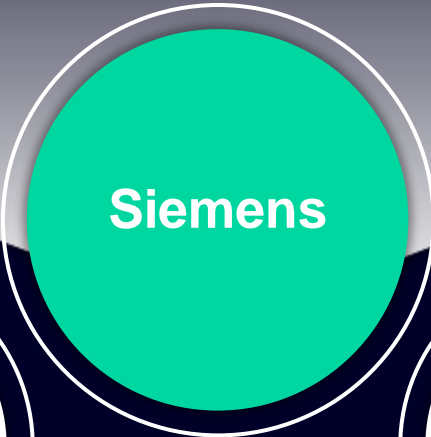

A new chapter in the history of Siemens AG

Company setup as of October 1, 2020

Businesses

Digital Industries



Smart Infrastructure



Mobility



Siemens Advanta



Portfolio Companies



Siemens Healthineers¹



Countries

Service & Governance

¹ Publicly listed subsidiary of Siemens; Siemens Healthineers with its own setup for Countries and Service & Governance

CEO Cedrik Neike
CFO Rudolf Basson
HQ Nuremberg, Germany



Digital Industries

Factory Automation

Motion Control

Process Automation

Software

Customer Services

Siemens Business Unit Motion Control (MC)

CEO Achim Peltz
CFO Bernd Ulbricht
HQ Erlangen, Germany

General Motion Control (GMC)



Low Voltage Motors (LVM)



Machine Tool Systems (MTS)



R&D & Factories

Erlangen, DE

Chemnitz, DE

Bad Neustadt, DE

Renningen, DE

Nuremberg, DE

Maroldsweisach, DE

Tübingen, DE

Congleton, GB

Mohelnice, CZ

Frenštát, CZ

Nanjing, CN

Tianjin, CN

Yizheng, CN

Shanghai, CN

Guadalajara, MX

Portfolio Motion Control



Siemens Portfolio Motion Control

Motion Control (worldwide ~ 20,000 employees)

SINUMERIK



The perfect CNC solution for every machine tool and digitalization in machine tool manufacturing

SINAMICS



Low-voltage converters - the integrated drive family for every application

SIMOTICS



The right motor for every motion control task - the widest range of motors worldwide

SIMOGEAR



The complete spectrum of geared motors with all common types of gear unit, suitable for every application

The integrated product portfolio is the basis for highly productive machines and plants for the Digital Enterprise

SINAMICS

Portfolio Overview

SINAMICS frequency converter portfolio

Standard performance converters

- SINAMICS V20
- SINAMICS G120/G120C
- SINAMICS G130/G150



Distributed converters

- SINAMICS G115D
- SINAMICS G120D



Industry-specific converters

- SINAMICS G120X



Servo converters

- SINAMICS V90
- SINAMICS S210
- SINAMICS S120



High performance converters

- SINAMICS S120
- SINAMICS S150



0.05 kW – 1200 kW

Standard Performance Converters

SINAMICS

V20, G120C, G120, G130, G150

Standard Performance Converters

SINAMICS V20 – Cost-effective, reliable and easy-to-use

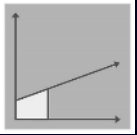

Continuous Motion
Basic Performance



Moving



Processing



Pumping, Ventilating
Compressing

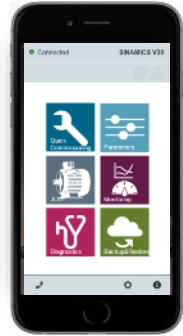

- ✔ **Easy to install**
 - Flexible mounting
 - EMC integrated filter (C1) for 1AC 230V
 - Compact design
- ✔ **Easy to use**
 - Parameter loading without power-supply
 - Smart Access Webserver Module
- ✔ **Easy to save money**
 - Eco and hibernation modes
 - High and low overload modes



1AC (200V) 0.12 – 3kW
3AC (400V) 0.37 – 30kW



Integrated Braking
Chopper¹



USS
Modbus RTU

1) Only for frame size FSD/FSE, external braking chopper available for FSA, FSB and FSC

Standard Performance Converters

SINAMICS G120C – Versatile, user-friendly and compact

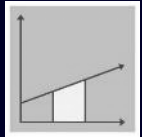

Continuous Motion
Medium Performance



Moving



Processing



Pumping, Ventilating
Compressing



3AC 0.55 – 132kW
(400V)



Integrated Braking
Chopper







PROFINET / Ethernet/IP
PROFIBUS DP
USS / Modbus RTU

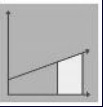
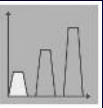

- ✓ **Compact frame size and side-by-side installation**
- ✓ **Energy Efficient**
Energy-saving functions as ECO-mode and PROFenergy
- ✓ **Compact frame size and side-by-side installation**
- ✓ **TIA - Totally Integrated Automation**
- ✓ **Safety functions**
Safe Torque Off (STO) integrated as a standard

Standard Performance Converters

SINAMICS G120 – Multifunctional, combinable and safe

-  Continuous Motion
High Performance
-  Discontinuous Motion
Basic Performance
-  Moving
-  Processing
-  Pumping, Ventilating
Compressing
-  Positioning



PM240-2
PM250

+



CU230P-2
CU240E-2
CU250S-2





+



BOP-2
IOP-2

=



-  **Technology**
Safety integrated basic and extended and **EPOS mode**.
-  **Modularity**
Lower stock inventory and simple, fast service
-  **Interfaces**
Full TIA integration, building systems, third-party systems
-  **Energy efficiency**
PROFenergy, **energy recovery** and saving mode, etc.
-  **Ruggedness**
Reliable operation and a long service life

1/3AC 0.55 – 250kW
(200V, 400V, 690V)



Int. Braking Chopper
(PM240-2)
Energy recovery
(PM250)



PROFINET / EtherNet/IP
PROFIBUS DP
USS / Modbus RTU
CANopen

Standard Performance Converters

SINAMICS G130/G150 – The universal converter for high power ratings

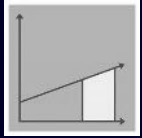

Continuous Motion
High Performance



Moving



Processing



Pumping, Ventilating
Compressing



3AC 110 – 2700kW
(400V, 500V, 690V)



Integrated Braking
Module¹



PROFINET / EtherNet/IP
PROFIBUS DP
USS / Modbus RTU
CANopen

G130
Built-in unit



G150
Cabinet unit



- ✓ **Cost saving** as a result of the high energy efficiency
- ✓ **Quiet operation and compact design**
- ✓ **Service-friendly** thanks to device modules that are easy to access
- ✓ **Integrated web server** functionality
- ✓ **Easy adaptable** to address many applications, thanks to wide range of components



Distributed Converters

SINAMICS
G115D, G120D

Distributed Converters

SINAMICS G115D – The specialized solution for conveyor applications

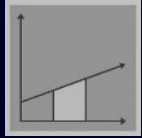

Continuous Motion
Medium Performance



Moving

IP65¹



Intralogistics



Airports



Automotive



F&B

Motor Mounted
(MM)

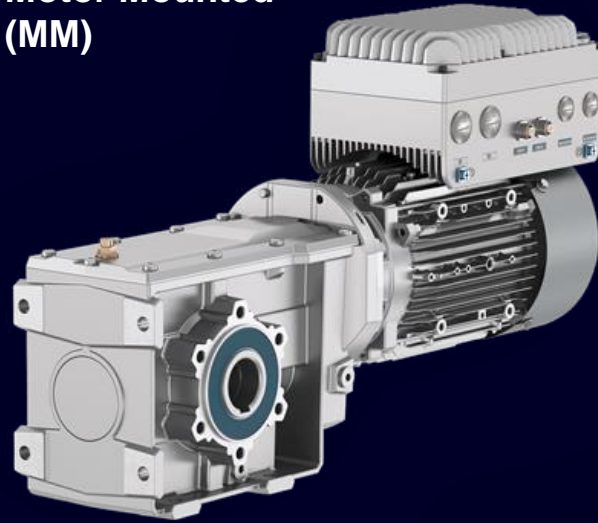

Wall Mounted
(WM)

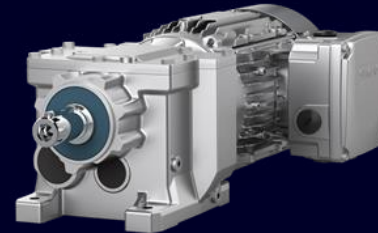
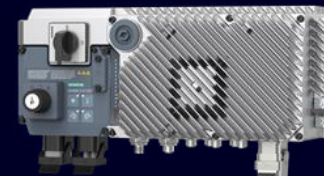

Simple setup and optimized user interface via Startdrive / SAM



Robust design enables operation at harsh environments



Consistent communication fieldbuses and fit for digitalization



Dedicated for conveyor technology applications



Safety integrated STO / PROFIsafe as standard



3AC 400V
0.37 – 4kW (MM)
0.37 – 7.5kW (WM)



Integrated Braking Module



PROFINET / Ethernet/IP
AS-Interface²
I/O Communication²

1) MM: IP55 (limited by geared motor) or optional IP65 / UL rating follows geared motor (compact system)

WM: IP65 (connector version) or IP66 (gland version) / UL type 4x

2) In 2nd Step

Distributed Converters

SINAMICS G120D – The specialist for demanding applications – with positioning capability



Continuous Motion
High Performance

Discontinuous Motion
Basic Performance

IP65¹

Moving

Positioning



- ✓ **Technology**
Safety functions, FFBs and positioning control **EPOS**.
- ✓ **Modularity**
Lower stock inventory and simple, fast service
- ✓ **Full TIA integration**
Simple commissioning using prompted parameterizing software
- ✓ **Energy efficiency**
Innovative power electronics with **energy feedback**
- ✓ **Ruggedness**
Rugged and compact design with plug connectors and IP65

3AC 0.75 – 7.5kW
(380 – 500V)



Energy recovery



PROFINET /
EtherNet/IP
PROFIBUS DP



Industry Specific Converters

SINAMICS
G120X

Industry Specific Converters

SINAMICS G120X – The specialized solution for Pump & Fan applications

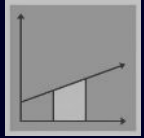

Continuous Motion
Medium Performance



Pumping, Ventilating
Compressing



Water/WW



HVAC



- ✓ **Cost efficient**
Supports high efficiency motors²: PMSM + SRM
- ✓ **Simple setup** and optimized user interface
- ✓ **Grid friendly**
Integrated full **DC-link choke** assures reduced harmonics
- ✓ **EMC compliant** and **long cable lengths** without output chokes
- ✓ **Robust and reliable**
3C3 coating, and Safety functions STO SIL3 HW



1/3AC (200V)	0.75 – 55kW
3AC (400V)	0.75 – 560kW
3AC (690V)	3 – 630kW



Integrated DC-link choke¹



PROFINET / EtherNet/IP
PROFIBUS DP
BACnet MS/TP / USS /
Modbus RTU

1) Only for frame sizes A – G, for FSH and J refer to the manual
2) Refer to de manual

PMSM: Permanent Magnet Synchronous Motor
SRM: Synchronous Reluctance Motor



Servo Converters

SINAMICS
V90, S210

Servo Converters

SINAMICS V90 – The performance-optimized and simple servo drive system



Discontinuous Motion
Basic Performance



Moving



Processing



Positioning



- ✓ **Performance-optimized**
Advanced one-button tuning and real-time auto tuning
- ✓ **Easy-to-use**
Plug & play design and graphic user interface V-Assistant tool
- ✓ **Cost effective**
EPos, integrated into STEP-7 Professional (PROFINET version)
- ✓ **Reliable operation**
High degree of motor protection and Safety Integrated **STO** HW function



1/3AC 0.05 – 0.75kW
3AC 0.4 – 7kW
(200V, 400V)



Integrated Braking
Resistor



PROFINET
PTI - Pulse Train Input

Servo Converters

SINAMICS S210 – The performance-optimized and simple servo drive system



Discontinuous Motion
Medium Performance



Moving



Processing



Positioning

1AC 200V
version



3AC 400V
version



- ✓ **Compact design - High Performance**
Dedicated Motor and DC Coupling¹ for optimal performance
- ✓ **Optimal together with SIMATIC controller**
Easy setup of entire Systems
- ✓ **Integrated Safety Functionality**
Basic and extended Safety Functionalities via PROFIsafe
- ✓ **Simple installation with One Cable Connection**
1FK2 Motors matched to the System UL Certification



1/3AC 0.05 – 0.75kW
3AC 0.4 – 7kW
(200V, 400V)



Integrated Braking Resistor and EMC filter



PROFINET







High Performance Converters

SINAMICS

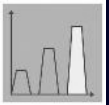
S120, S120M, S150

High Performance Converters

SINAMICS S120 single-axis drive AC/AC

-  Continuous Motion
High Performance
-  Discontinuous Motion
High Performance
-  Moving
-  Processing
-  Positioning
-  Pumping, Ventilating
Compressing
-  Machining



PM240-2
Blocksize format

Power Module
Chassis format









CU310-2

CUA31; CUA32
(expansion for multi-axis applications)



BOP20



-  **High degree of flexibility**
With highly scalable power and performance
-  **Integrated technological functions**, Epos, DCC, PID technology controller...
-  **Energy efficiency**
Energy-saving functions
Adaptation to the process
-  **Robustness**
Reliable operation and a long service life
-  **Extensive range of options**
Matched 1FK2 and 1FT7 Motors
-  **Safety Integrated functions**
Basic, extended and advanced



PM240-2 (200V, 400V, 690V)
1/3AC 0.55 – 250kW
Chassis (400V, 690V)
3AC 110 – 250kW









**Integrated Braking
Chopper**



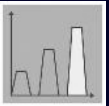



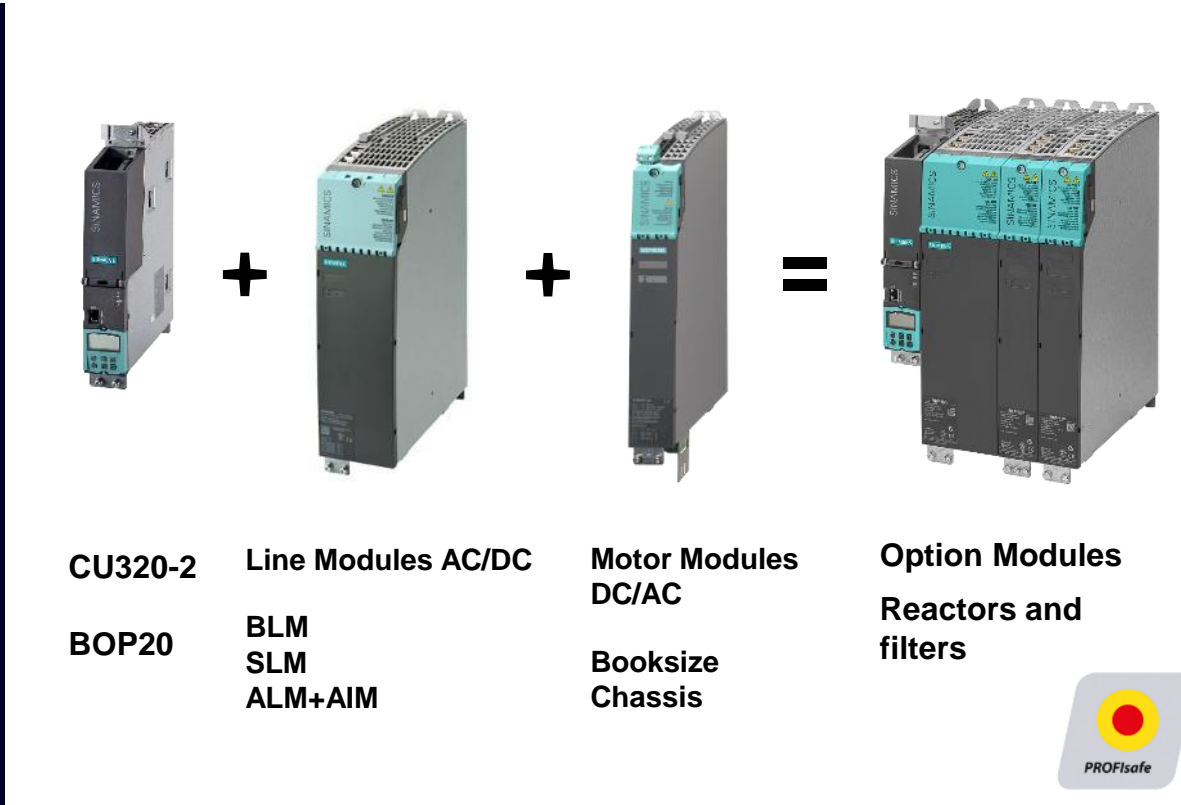

**PROFINET /
EtherNet/IP
PROFIBUS DP**

High Performance Converters

SINAMICS S120 multi-axis drive DC/AC

-  Continuous Motion
High Performance
-  Discontinuous Motion
High Performance
-  Moving
-  Processing
-  Positioning
-  Pumping, Ventilating
Compressing
-  Machining



-  **High degree of flexibility**
With highly scalable power and performance
-  **Integrated technological functions**, Epos, DCC, PID technology controller...
-  **Energy efficiency**
Energy-saving functions
Adaptation to the process
-  **Robustness**
Reliable operation and a long service life
-  **Extensive range of options**
Matched 1FK2 and 1FT7 Motors
-  **Safety Integrated functions**
Basic, extended and advanced

Booksize (400V)
3AC 1.6 – 107kW
Chassis (400V, 690V)
3AC 110 – 6840kW



Energy recovery¹



PROFINET / EtherNet/IP
PROFIBUS DP
USS / Modbus TCP
CANopen

1) Depending on the infeed

BLM: Basic Line Module
SLM: Smart Line Module

ALM: Active Line Module
AIM: Active Interface Module

High Performance Converters

SINAMICS S120M distributed multi-axis system DC/AC

Continuous Motion
High Performance

Discontinuous Motion
High Performance

Moving

Processing

Positioning

Pumping, Ventilating
Compressing

Machining

IP65²

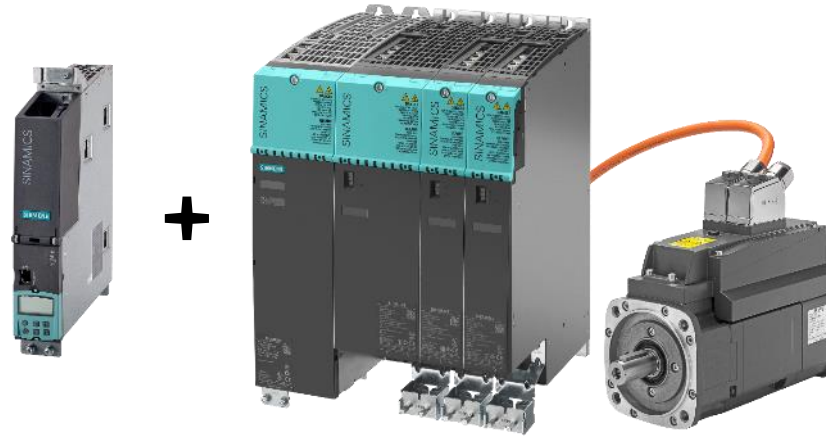

CU320-2
BOP20

**Line Modules
AC/DC**
**BLM
SLM
ALM+AIM**

**Adapter
Module**
AM600

S120M



- ✓ **High degree of flexibility**
Up to 12 distributed drive units
- ✓ **Integrated technological functions**, Epos, DCC, PID technology controller...
- ✓ **Energy efficiency**
Energy-saving functions
Adaptation to the process
- ✓ **Robustness**
Reliable operation and a long service life
- ✓ **Reduced** control cabinet volume and **longer** power cables
- ✓ **Safety Integrated functions**
Basic, extended and advanced



0.25 – 1.5kW
(510 – 700V DC)

Energy recovery¹

PROFINET / EtherNet/IP
PROFIBUS DP
USS / Modbus TCP
CANopen

1) Depending on the infeed
2) Only for S120M

BLM: Basic Line Module
SLM: Smart Line Module

ALM: Active Line Module
AIM: Active Interface Module

High Performance Converters

SINAMICS S150 – Multifunctional, precise and capable of energy recovery

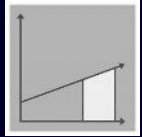

Continuous Motion
High Performance



Discontinuous Motion
Medium Performance



Moving



Processing



Pumping, Ventilating
Compressing



Multifunctional

Versatile for a wide range of applications. Ready to connect drive cabinet system



High dynamic

Superior performance even for high demanding applications
High dynamical braking function



Energy recovery

Significant energy savings. Almost negligible grid distortion (<<1%) due to Clean Power Filter



Ready for Digitalization

Simplified engineering process with due to various data offering (3D, EPLAN)



3AC 110 – 800kW
3AC 75 – 1200kW
(480V, 690V)



Optional highly
dynamic braking
systems



PROFINET / EtherNet/IP
PROFIBUS DP
USS / Modbus TCP
CANopen

Selection & Configuration Tools

Tools to enable easy selection and configuration of the drive system



TIA Selection
Tool (SIZER)



DT-Configurator



SINAMICS SELECTOR



SinaSave



Startdrive

Value-add Topics



Value-add Topics



Digitalization in Drive Technology



MindSphere IoT Value Plan

Create an account on our cloud platform MindSphere to collect and analyze data from your machines.



SINAMICS Analyze MyDrives

The tool that allows you to monitor multiple drive systems from a single point. ([Link](#))



TIA Portal drive integration with SINAMICS Startdrive

The same operating concept, elimination of interfaces and the high level of user friendliness make it possible to quickly integrate SINAMICS converters into the automation environment and commission them using the TIA Portal.



SINAMICS Safety Integrated

The drives are simply linked to SIMATIC, SINUMERIK and SIMOTION controls, and through communication via **PROFIsafe**, are perfectly harmonized with these.

- Shorter commissioning times
- Higher cost effectiveness
- Lower wiring costs.



Digital Enterprise Services

Digital Enterprise Services



Consulting Services

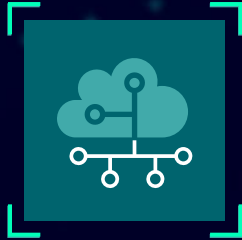

Engineering and Integration Services

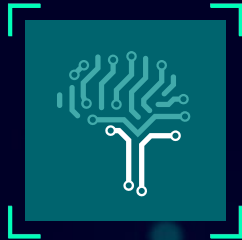

Analytics and Artificial Intelligence Services



Industrial Security Services



Training Services



Support Services



Field and Maintenance Services



Spare Parts Services



Repair Services

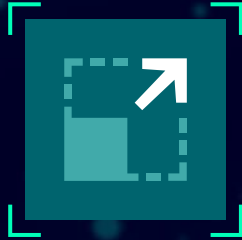

Retrofit and Modernization Services



Service Contracts

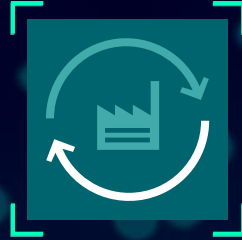

Service Programs and Platforms

SINAMICS Drive Service 'Extended Exchange'

Available for:

SINAMICS V20, V90, G110, G110D, G120, G120C, G120D, G120P, G120X, S110, S120, MICROMASTER



<https://myregistration.siemens.com/>

Scope of service

- Service includes exchange of product, or repair at a Siemens Repair Centre or a Siemens approved partner, and excludes labor on-site
- Option “+3 years” and “+5 years” are available to purchase via Service Product Codes (MLFBs)
- Option “+3 years” and “+5 years” requires product registration. The Customer will also benefit from the 6 months FOC extension
- Customer received Drive Service Extended Exchange Certificate as proof of service
- Can be purchased through standard Siemens sales channels at point of product sale or up to 12 months following product manufacture

| Contact

Published by Siemens AG

Ana Martinez

Regional Marketing Manager

DI MC GMC CCE 1

Siemensova 1

155 00 Prague

Czechia

Mobile +420 734 180 951

E-mail anabelen.martinez_espejo@siemens.com