

REVISION	DATE	BY	DATE	BY
		DRAWN	17/08/22	RM
		CHEK'D		
		VERIF'D		

Siemens Industry, Inc.	
CUSTOMER	
ORDER NO.	DWG. NO.
	3B5S300FD16
	SH 1 OF 3

# SIEMENS

<p>CATALOG NO. 3B5S300FD16</p> <p>SERIAL NO.</p> <p>300 kVA 60 Hz 3 PHASE</p> <p>4.1 % IMP AT 135 °C</p> <p>115 °C RISE 30 °C AVG. AMBIENT</p> <p>220 °C TEMP CLASS 40 °C MAX. AMBIENT</p> <p>PRIMARY ( X1 X2 X3 ) 208 V 10 kV BIL</p> <p>SECONDARY( H0 H1 H2 H3 ) 480Y/277 V 10 kV BIL</p> <p>WINDING MATERIAL AL</p> <p>ENCLOSURE TYPE 3R WEIGHT 2050LBS</p> <p>ENERGY EFFICIENCY EXCEEDS CSA C802.2-2012 DOE 10 CFR PART 431:2016</p> <p>SPACINGS BETWEEN ANY VENTILATED ENCLOSURE PANEL AND ANY ADJACENT WALL SHALL BE A MINIMUM OF 5 INCHES EXCEPT WHEN WALL MOUNTED USING APPROVED WALL MOUNTING KIT RATIO ERROR IS TO THE NEAREST TURN PER STANDARD</p> <p>TRANSFORMER SUITABLE FOR STEP UP OPERATION ONLY</p> <p>SUITABLE FOR INDOOR OR OUTDOOR LOCATIONS BEFORE HANDLING, INSTALLING AND OPERATING, SEE INSTRUCTION MANUAL</p> <p>NEMA Class ANN Dry Type Transformer Siemens Industry, Inc. Norcross, GA <small>dsu0086e1</small></p>	<p style="text-align: center;">SERIES H 3 PHASE</p>  <p style="text-align: center;">VOLTS 218 208 198</p> <p style="text-align: center;">CONNECT 1 2 3</p>	<p style="text-align: center;">TYPE K</p> <p style="text-align: center;">UL LISTED E112313</p> <p style="text-align: center;">SP TRANSFORMER LR 3902</p> <p style="text-align: center;">SEISMIC QUALIFICATIONS, FLOOR MOUNT ONLY OSP-0136-10 IBC 2012/ASCE 7-10 SDS&lt;=2.0g Z/h=1 Ip=1.5</p>
---	---	---

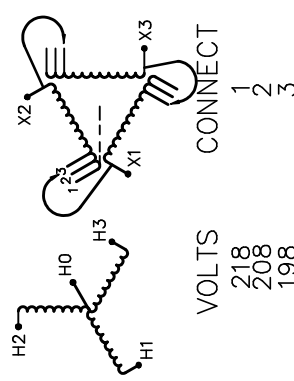

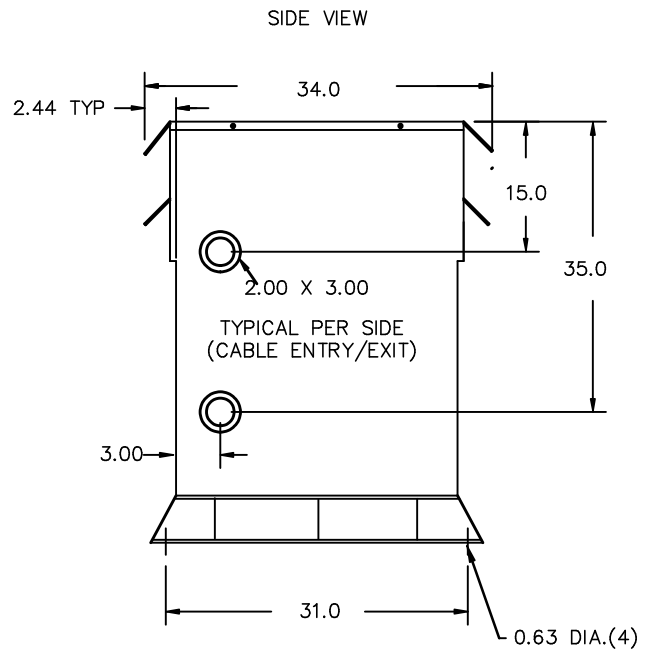
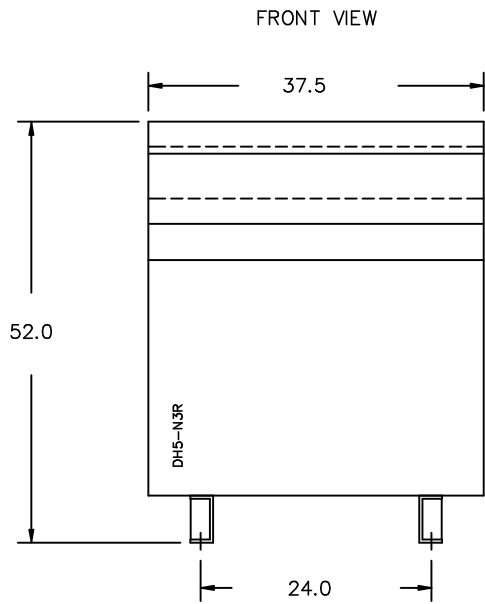

All Dimensions in inches

ENCLOSURE COLOR :ANSI 61 GREY – OUTDOOR

HV TERMINAL DETAIL

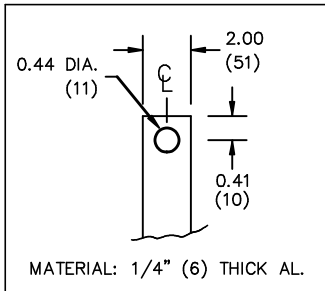

HO TERMINAL DETAIL

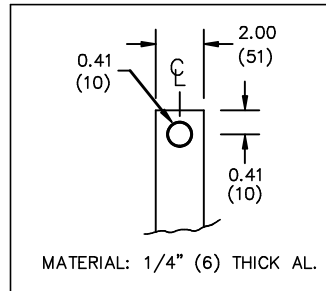

LV TERMINAL DETAIL

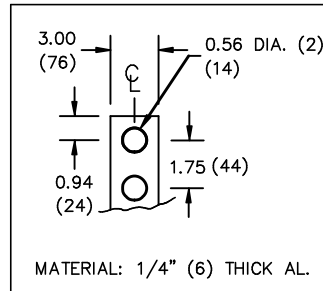

CUSTOMER NOTES:

- HV TERMINATED AT BOTTOM FRONT
- HO TERMINATED AT BOTTOM FRONT
- LV TERMINATED AT TOP FRONT

Siemens Industry, Inc.

REVISION	DATE	BY	DATE	BY
		DRAWN	17/08/22	RM
		CHEK'D		
		VERIF'D		

CUSTOMER	
ORDER NO.	DWG. NO. 3B5S300FD16
SH 2 OF 3	

ENCLOSURE BOTTOM VIEW

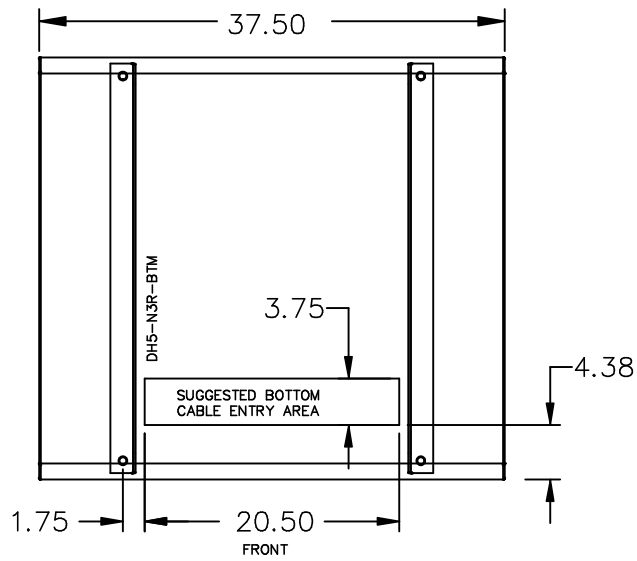

NOTE:  
 WHEN BOTTOM CABLE ENTRY IS OPTED, THE SPACE USED FOR CONDUITS IN THE FRONT OF THE TRANSFORMER SHOULD NOT OBSTRUCT MORE THAN 50% OF THE FRONT AIR INTAKE AREA DEFINED BETWEEN THE BOTTOM PLATE AND THE SUPPORTING LEGS. SEE MANUAL FOR ADDITIONAL INFORMATION

Siemens Industry, Inc.

REVISION	DATE	BY	DATE	BY
			17/08/22	RM

CUSTOMER	
ORDER NO.	DWG. NO. 3B5S300FD16
	SH 3 OF 3