

AMR medium-voltage vacuum roll-in replacement circuit breakers

ANSI 5 kV at 250-350 MVA, 1,200-2,000 amperes

Roll-in replacement breakers provide a cost-effective way to upgrade to current vacuum technology while increasing equipment reliability and minimizing downtime. Siemens provides the experience your company needs to successfully extend the life of your equipment. Our circuit breakers are manufactured using the same fixtures as the original Allis-Chalmers breakers.

Why replacement breakers?

- Increased reliability and performance
- Reduced operating and maintenance expenditures
- Reduced downtime, minimal changeover time during upgrade
- Preserved investment in existing cubicles
- Improved employee and environmental safety

Why Siemens?

- **Long operational life**
Siemens replacement breakers have an expected life of 30,000 mechanical operations and a maintenance interval of 10 years or 10,000 mechanical operations, which far exceeds most operational requirements in industrial and utility applications.
- **Direct interchangeability**
Siemens replacement breakers, including those that utilize our patented MOC-Saver™ design, are interchangeable with no adjustments required from cubicle to cubicle regardless of the number of MOC switch banks within the existing cubicles.
- **Extensive experience**
Siemens has supplied thousands of medium-voltage replacement breakers from our manufacturing facility in Wendell, North Carolina, successfully completing over 750 projects since 1983. Over 350 breakers are located in nuclear 1E rated applications.

- **Standardized design**

Siemens utilizes the 3AH operator for our complete family of over 150 different medium-voltage replacement breaker designs, reducing spare parts and training requirements. Over 350,000 3AH series circuit breakers are in service worldwide.

3AH operator features:

- Spring charge motor mechanism – lifetime lubricated gear box
- Operating linkage – machine parts versus stamped metal
- Change-out of components – easily accessible
- Vacuum contact erosion – indication easily verifiable



Siemens AMR
(replacement for Allis-Chalmers AM)

For Allis-Chalmers AM

The following circuit breakers are available as pre-engineered designs:

Replacement circuit breaker	Nominal voltage class	Nominal 3-phase MVA class	Maximum voltage	Voltage range factor	Interrupting time	Full wave withstand test voltage	Continuous current (60 Hz)	Short circuit current (at max kV)	Close and latch capability	Nominal weights
			E	K				I	1.6 x KI	
	kV	MVA	kV rms		Cycles	kV Peak	Amperes	kA rms	kA rms	lbs.
5AMR-250	4.16	250	4.76	1.24	5	60	1,200, 2,000	29	58	750
5AMR-350	4.16	350	4.76	1.19	5	95	1,200, 2,000	41	78	800

Dimensions (inches)

	5AMR-250/350
A	65.47
B	21.32
C	11.00
D	19.85
E	25.37

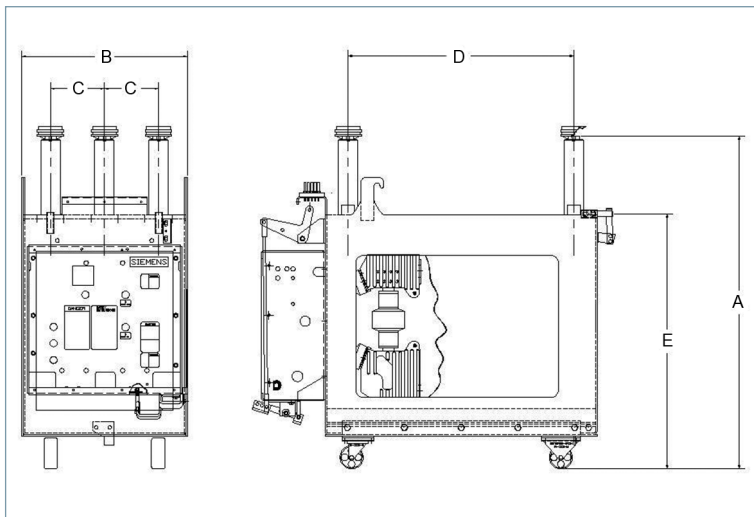

Sample dimensional diagram – AMR

Siemens Industry, Inc.
7000 Siemens Road
Wendell, NC 27591

For more information, please contact
our Customer Support Center.
Phone: 1-800-333-7421

usa.siemens.com

Order No: EMTS-B40008-00-4AUS
Printed in USA

©2017 Siemens Industry, Inc.

The technical data presented in this document is based on an actual case or on as-designed parameters, and therefore should not be relied upon for any specific application and does not constitute a performance guarantee for any projects. Actual results are dependent on variable conditions. Accordingly, Siemens does not make representations, warranties, or assurances as to the accuracy, currency or completeness of the content contained herein. If requested, we will provide specific technical data or specifications with respect to any customer's particular applications. Our company is constantly involved in engineering and development. For that reason, we reserve the right to modify, at any time, the technology and product specifications contained herein.