

SIEMENS

Indoor/Outdoor Modular Tap Box

Catalog Number

WT3800PU

Enclosure

Type 3R

Module Rating:

800 Amps, Max.
208Y/120 Volts~, 3 Phase, 4 Wire
240/120 Volts~, 3 Phase, 4 Wire, Delta (B Phase is High Leg)

For installation by Qualified Person in accordance with all local electrical codes and/or the National Electrical Code®.

For overhead or underground service.

Use 75°C Copper or Aluminum Conductors.

Terminals A, B, C and N: See Lug Chart on adjacent diagram for applicable lug kits, wire size and torque information.

Ground Terminal G: Wire size #4-300 kcmil. Torque terminal to 250 lb.-in.

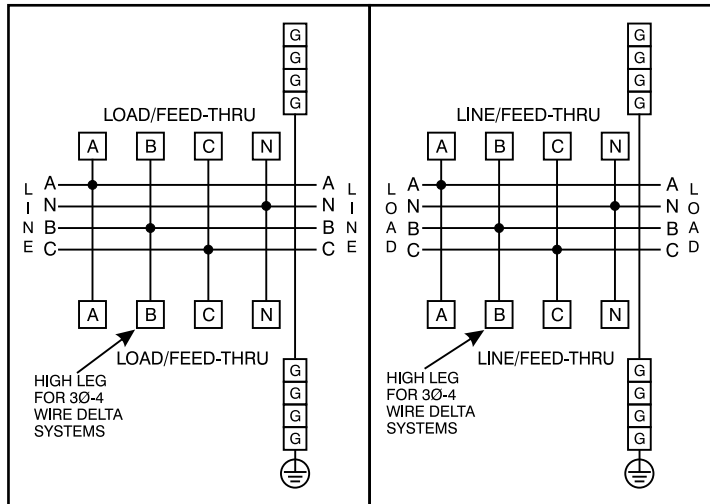

See adjacent label for additional marking information.

Siemens Industry, Inc. Norcross, Georgia U.S.A.

DH1

40901014 0101 Rev.00

© The National Electrical Code is a registered trademark of the National Fire Protection Association.
© 2018 Copyright Siemens Industry, Inc.

SIEMENS

Lugs for Phase and Neutral Connections (not supplied)

Lug No. ①	MFG	Wire Range	Type	No. Wires per phase	Torque (lb.-in.)
LK32600N2	Siemens	#2-600 kcmil	Mechanical	2	500
LK32750N2	Siemens	300-750 kcmil	Mechanical	2	500
LK33500N2	Siemens	1/0-500 kcmil	Mechanical	3	500 ②
LK34500N2	Siemens	1/0-500 kcmil	Mechanical	4	500
2ACL-500	ILSCO	500 kcmil	Compression	3	NA ③
2ACL-600	ILSCO	600 kcmil	Compression	2	NA ③
2ACL-750	ILSCO	750 kcmil	Compression	2	NA ③

- ① Order one mechanical lug kit for mains and neutral. Contact lug manufacturer for compression lug quantities supplied for each kit.
② Kit contains more than one lug type.
③ See lug manufacturer's instruction sheet supplied with the connector for tool, die, and number of crimps.

Short Circuit Current Rating

This device has a maximum short circuit current rating of 100,000 Amps RMS symmetrical at 240 Volts ~ when protected by 800 Amp maximum Class T fuses or Siemens type MXD6 or HMXD6 circuit breaker rated not more than 800 Amps. Rating is limited to the interrupting capacity of the fuses or circuit breaker installed ahead of this device.

Use HD Type Hubs if required

Trade Size (in) Catalog No.

2"	EC56854
2-1/2"	EC56855
3"	EC56856
3-1/2"	EC56857
4"	EC56858

IMPORTANT - for use with:

Module Description	Siemens Series#
Main Breakers	WB(M), WEB(M), WXB, BFT
Switches	WMP, WS, WES, WXS
Tap/Terminal Boxes	WTB, WET, WT_PU, WTBN, WBT
Pull Boxes	WMMB
Meter Module	(W)MM, (W)MT, (W)ML, (W)MK, (W)MLZ(F), (W)MN
Meter Combinations	WC, WCL, WCT,
Extension Box	WSP, WSPD
Bussed Elbow	BE, WELB

Connect Modules Using:

Quick Connect

Cat. No.

QC4

Torque

400-440 lb-in (35-36 ft.-lb.)

Important: Do not allow petroleum based (hydrocarbon) sprays, chemicals, solvents or any paint to contact interior components. Petroleum based chemicals can cause degradation of electrical insulating materials.

Siemens Industry, Inc. Norcross, Georgia U.S.A.

DH1

40901014 0201 Rev.00

© 2018 Copyright Siemens Industry, Inc.