

## Optimizing processes in tank farms with an integrated system

Modern tank farms are often located in extreme environmental locations. Yet, amid these harsh conditions, they must deliver a range of functions for successful operation. This includes reliable data transmission 24/7, uninterrupted transparency and availability, plus the enhanced efficiency to avoid costly downtimes. As a partner with comprehensive knowledge of tank farms, Siemens provides reliable and robust network topology. Our highly customizable solutions, including digitalization, enables an integrated system and high performance.

### Advantages

- High availability via continuous operation 24/7 and redundant fiber optic topology, plus easy and quick replacement of faulty device without specialist knowledge
- CAPEX and OPEX optimization due to decrease of non-productive time and meantime to restoration
- One-stop-shop for complete solutions
- saves commissioning time and permits easier integration
- Mitigation of HSSE incidents via wireless fail-safe communication
- Reliable data transmission: fast network recovery time (< 300 ms) including resilience to single point of failure while preventing data losses for critical applications

### Products used for this application

- **Industrial Ethernet switches – SCALANCE X-200 for Process Automation**  
Designed for use in PROFINET networks, these switches meet the special requirements of the process industry.
- **Industrial Wireless communication – SCALANCE W**  
SCALANCE W devices offer reliable wireless communication at various automation levels according to the IEEE 802.11n standard.
- **Process instrumentation**  
Our comprehensive process instrumentation portfolio offers best-in-class transmitters for the widest range of applications.
- **Failsafe Controller – SIMATIC S7-400H**  
Specially designed for redundant and failsafe applications, the SIMATIC S7-400H controllers offer reliable and scalable functions.

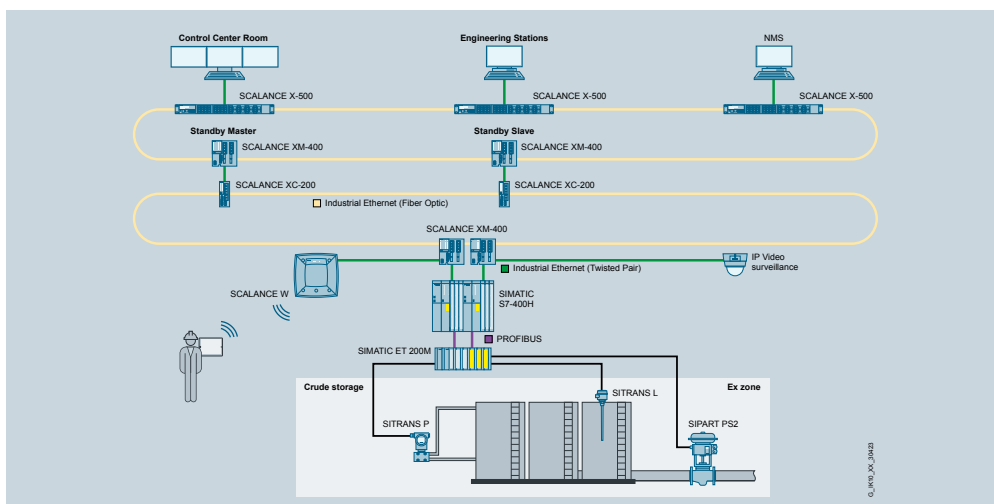

© 2016 Siemens AG