

Technical
article

New robust Industrial Ethernet Switches from Siemens for the Process Industry

Industrial Ethernet has been the network of choice in factory automation for many years and offers a powerful communication basis with PROFINET-based solutions. Industrial Ethernet is now getting ready to conquer the process automation as well. With the new switches from Siemens, the requirements for process automation products are ideally met. In doing so, the new switches support the transition from PROFIBUS to PROFINET in the process industry, and enable high-performance and at the same time cost-effective solutions of unprecedented dimensions.

The biggest challenge in the process industry lies in the fact that processes have to run to completion and must not be stopped. This means that the highest possible plant availability has to be ensured at all times in order to avoid stoppages and always achieve high productivity. Consequently, products used in the process automation must have first and foremost a robust and resistant hardware. At the same time, they require a highly efficient and powerful software to handle the increasingly complex processes and procedures.

The digitalization in the process automation entails such a high data quantity that in many cases a network topology based on the PROFIBUS standard (**Process Field Bus**) is no longer sufficient for its processing. Here, it is recommended to use a network topology on the basis of Industrial Ethernet in conjunction with a powerful communication protocol. The standardized PROFINET protocol (**Process Field Network**) offers all these features with respect to high availability and data transmission.

It offers a data rate of up to 100 Mbps to enable the transmission of large amounts of data (buzzword “big data”, download of recipes, etc.). Ruggedness and a secure communication for the data transmission are further additions delivered by the PROFINET protocol.

Above all, it is important to intelligently evaluate the large amounts of data so that an efficient maintenance (buzzword predictive maintenance) can be conducted, i.e., to recognize the need for repair or maintenance measures before it is too late and the plant has to be shut down. The new 9.0 version of the SIMATIC PCS 7 control system from Siemens offers many hardware and software innovations to capture or predict exactly such scenarios. With the PCS 7 process control system, the entire process down to the field level can be monitored. Various software functions enable the efficient evaluation of the large quantities of data and thus the introduction of measures for the optimization of the plant. As a result, maintenance measures required are identified early. This saves costs and time, and means investment protection through continuous optimization.

SCALANCE XF-200BA, the innovative Switches for the Process Industry

In order to meet these stringent requirements for a digitalization in the process automation and be able to set up corresponding networks, Siemens developed the SCALANCE XF-200BA switches on the IEEE 802.3 Ethernet standard. The switches can be seamlessly integrated into the SIMATIC PCS 7 V9.0 control system. Thanks to the flat construction in the ET 200SP design, the switches fit perfectly into any control cabinet for a space-saving installation. The connection of the data lines takes place via bus adapters. This method provides maximum flexibility in the choice of transmission medium. By simply changing the bus adapter, the transmission medium can be easily changed in a short time, for example, from copper to plastic fiber optic cable. This also brings an efficient spare parts inventory, since many of the new PROFINET-enabled products for the process automation share the bus adapter concept. An efficient spare parts inventory means that a bus adapter can be used in many products – such as the SIMATIC ET 200SP HA controller (**H**igh **A**vailability) or the SIMATIC CFU (**C**ompact **F**ield **U**nit), the SIMATIC ET 200SP, the IE/PB LINK PN IO, and the SCALANCE XF204-2BA and SCALANCE XF204-2BA DNA switches.

Each SCALANCE XF-200BA switch supports up to four 100 Mbps ports. To minimize the number of broadcasts in the network, virtual LANs (VLANs) divide the physical network into virtual areas. A high availability of machinery and equipment is provided by redundancy protocols – such as the HRP protocol (**H**igh **S**peed **R**edundancy **P**rotocol) and the MRP protocol (**M**edia **R**edundancy **P**rotocol). In the event of a fault, these protocols are used to switch over to the redundant path without a loss of communication. These and other functions – such as RMON (**R**emote **N**etworking **M**onitoring) and link aggregation – complete the firmware spectrum.



SCALANCE X products for the use in the process industry

More stringent Requirements in the Process Industry

Products employed for projects in the various sectors of the process automation should have properties that allow their use in any environment. They need an extended temperature range of -40 to +70 °C so that they can be used in all climatic conditions, conformal coating to withstand the harsh environments in the process automation, and an extended installation altitude of up to 4000 m for project implementations in higher geographical regions. The new SCALANCE switches from the XF-200BA product family fully meet these hardware requirements. In addition, these products can be employed in potentially explosive areas, for which even higher demands are placed on the hardware. The two products SCALANCE XF204-2BA and SCALANCE XF204-2BA DNA hence possess certified hardware properties that permit their use in potentially explosive areas of zone 2. In addition, the products follow the recommendations of NAMUR NE 21 for electromagnetic compatibility of equipment in process technology.

PROFINET conquers the Process Industry

Based on the IEEE 802.3 Ethernet standard, the network nodes communicate with the PROFINET protocol. The world-leading standard PROFINET protocol meets the high requirements of the process automation in the Industry 4.0 environment, which also ensures the continuous monitoring of the processes. Information from the processes has to be quickly and reliably communicated, e.g., to a control room, and evaluated. PROFINET allows the setup of reliable and flexible communication networks in electrical or optical line, star and ring structures. The intelligent data transfer significantly increases the availability and speed of the data transmission compared to PROFIBUS, and thus also the performance of the entire network. Existing plants with PROFIBUS can be easily expanded with PROFINET components, for example, by using the IE/PB LINK PN IO. With this link, PROFIBUS devices can be integrated into a PROFINET

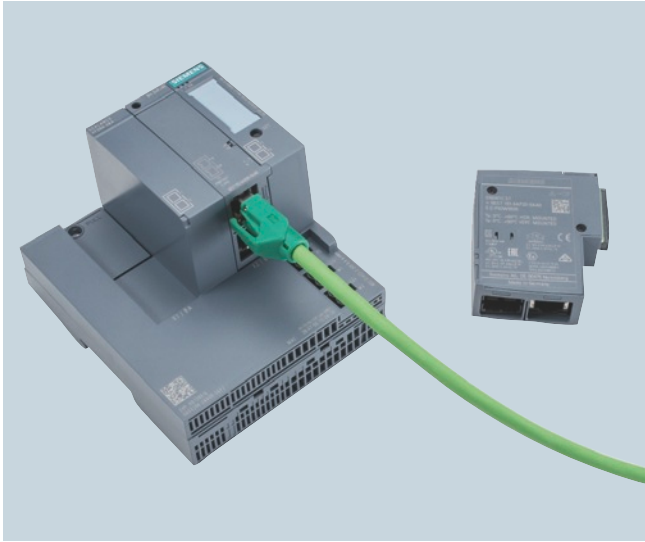

SCALANCE XF204-2BA with two bus adapters for the use in the process industry

application. The seamless transition between Industrial Ethernet and PROFIBUS makes the migration from PROFIBUS to PROFINET especially easy. Networks are created with an end-to-end communication from the control room down to the field level. The secure data transmission also protects the know-how against unauthorized access.

The Y-Switch – Enhancement of the System Redundancy

In order to realize this high performance, it is indispensable to design processes redundantly. The implementation works as follows: To achieve a high plant availability, automation systems controlling the process flow are executed redundantly (highly available).

In the event of a fault, e.g., the failure of part of the automation system, the redundant part of the highly available automation system bumplessly takes over the process control. This layout is called “system redundancy”. Thanks to the additional redundant execution of the plant network (R1 system), the highest possible plant availability is achieved.

To enable the connection of non-redundant systems to a redundant network, a Y-switch is required. It connects so-called S2 devices (simple system redundancy), which are set up in an MRP ring, to an R1 system (redundant PROFINET configuration). Products possessing S2 device functionality can establish two connections to the automation system. In addition to the various variants of system redundancy (S2 and R1), there is also the option of redundantly executing the medium itself. This is called MRP (Media Redundancy Protocol). In an MRP ring, it is mandatory for the nodes to be connected to two interfaces – in order to close the ring. By means of the MRP protocol, up to 50 nodes can be configured in the ring. Reconfiguration times as low as 200 milliseconds can be achieved. If a component in part of the ring installation fails, the connections between the nodes is maintained – there is no loss of communication. The SCALANCE XF204-2BA DNA Y-switch (see figure 3) connects such an MRP ring to the redundant structure of the CPUs (as shown in figure 2). With the Y-switch, PROFINET devices with simple system redundancy (S2) can thus also be connected via an MRP ring and then to a redundant network (R1 system). The Y-switch ensures that the network separation is maintained on the redundant network – in order to guarantee the maximum availability for the plant. In addition, SCALANCE XF204-2BA switches are employed to form the network with industrial-grade process switches.

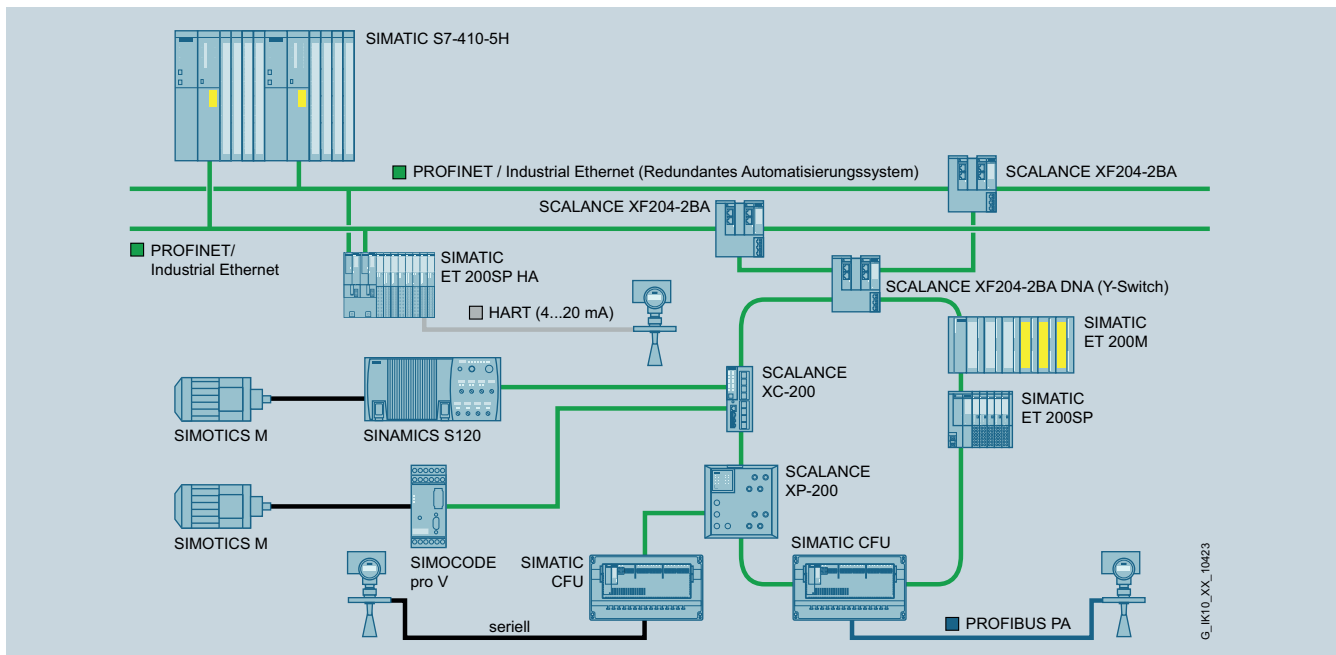

Integration of S2 devices into a highly available R1 system by means of the SCALANCE XF 204-2BA DNA switch

The SCALANCE XF204-2BA DNA (dual network access) Y-switch is characterized by the following properties:

- No configuration is necessary, the Y-switch is transparent. The Y-switch can thus be used “out of the box” and offers maximum simplicity.
- Up to 50 nodes can be configured in an MRP ring.

Other industrial-grade switches for the process industry include the SCALANCE XP-200 with IP65 rating and the XC-200. These likewise meet the -40 to +70 °C temperature range, are conformal coated, and are suitable for an extended installation altitude of up to 4000 m.

With the advent of Industrie 4.0 into the process industry, new demands are placed on the automation.

These are addressed by Siemens with the new PCS 7 V9.0 process control system, which now makes possible powerful plants based on PROFINET.

The newly created SCALANCE XF204-2BA DNA (Y-switch) and XF204-2BA Industrial Ethernet switches in conjunction with other network components from the SCALANCE product family form the basis for powerful communication networks of next-generation automation solutions in the process industry.

www.siemens.com/y-switch

Security information

In order to protect plants, systems, machines and networks against cyber threats, it is necessary to implement – and continuously maintain – a holistic, state-of-the-art industrial security concept. Siemens' products and solutions only form one element of such a concept. For more information about industrial security, please visit <http://www.siemens.com/industrialsecurity>

Siemens AG
Process Industries and Drives
Process Automation
Postfach 48 48
90026 Nürnberg
Germany

© Siemens AG 2017
Subject to change without prior notice
PDF
Technical article
FAV-276-2017-PD-PA-V01
BR 1217 / 4 En
Produced in Germany

The information provided in this catalog contains merely general descriptions or characteristics of performance which in case of actual use do not always apply as described or which may change as a result of further development of the products. An obligation to provide the respective characteristics shall only exist if expressly agreed in the terms of contract. Availability and technical specifications are subject to change without notice.

All product designations may be trademarks or product names of Siemens AG or supplier companies whose use by third parties for their own purposes could violate the rights of the owners.

siemens.com/y-switch