



Model 5000 Grade Crossing Predictor Field Manual

**Document Number: SIG-00-13-03, Version: A.6
August 2013, Revised June 2014, October 2014,
December 2015, July 2017, August 2018, & August
2019**

PROPRIETARY INFORMATION

Siemens Mobility, Inc. has a proprietary interest in the information contained herein and, in some instances, has patent rights in the systems and components described. It is requested that you distribute this information only to those responsible people within your organization who have an official interest.

This document, or the information disclosed herein, shall not be reproduced or transferred to other documents or used or disclosed for manufacturing or for any other purpose except as specifically authorized in writing by Siemens Mobility, Inc.

TRANSLATIONS

The manuals and product information of Siemens Mobility, Inc. are intended to be produced and read in English. Any translation of the manuals and product information are unofficial and can be imprecise and inaccurate in whole or in part. Siemens Mobility, Inc. does not warrant the accuracy, reliability, or timeliness of any information contained in any translation of manual or product information from its original official released version in English and shall not be liable for any losses caused by such reliance on the accuracy, reliability, or timeliness of such information. Any person or entity who relies on translated information does so at his or her own risk.

WARRANTY INFORMATION

Siemens Mobility, Inc. warranty policy is as stated in the current Terms and Conditions of Sale document. Warranty adjustments will not be allowed for products or components which have been subjected to abuse, alteration, improper handling or installation, or which have not been operated in accordance with Seller's instructions. Alteration or removal of any serial number or identification mark voids the warranty.

See Back Cover for contact information

Copyright © 2013 – 2019 Siemens Mobility, Inc. All rights reserved.

TABLE OF CONTENTS

HOW TO USE THIS MANUAL	5
SYSTEM CUTOVER	5
MODEL 5000 GCP SYSTEM CUTOVER FORM.....	5
Equipment Needed:.....	5
WIRING OF KEYED INTERFACE CONNECTORS.....	6
External Wiring Connectors and Wire Size	6
Wire Preparation.....	6
Wire Insertion	7
CIRCUIT AND PROGRAMMING VERIFICATION	8
AUXILIARY EQUIPMENT CONNECTION AND SETUP	10
Ethernet Spread Spectrum Radio (ESSR)	10
MAINTENANCE CALL (MC) LIGHT	10
VERIFY OFFICE CONFIGURATION CHECK NUMBER	10
CALIBRATION	11
RECALIBRATION & REPROGRAMMING REQUIREMENTS DUE TO MODULE REPLACEMENT	11
RECALIBRATION REQUIREMENTS DUE TO PROGRAM CHANGES	12
RECALIBRATION REQUIREMENTS DUE TO TRACK EQUIPMENT CHANGES.....	13
CALIBRATION PROCEDURES	14
Tuning the 62785-f Tuned Joint Coupler.....	14
Calibrating a Track Module.....	18
ADJUSTING LAMP VOLTAGES FOR SSCC IIIi	33
General.....	33
Meter Reading Conversion Examples.....	33
SSCC IIIi LAMP VOLTAGE ADJUSTMENT	35
OPERATIONAL CHECKS	37
SSCC IIIi TEST MODE	37
SSCC TEST MENU	37
Types of Tests	37
Parameters for Timed Tests.....	38
Test Status Indications	38
GCP OPERATIONAL TEST MODE	39
SSCC IIIi OPERATIONAL TESTS.....	42
SEAR ACCESSORY GROUP	44
INSTALLATION OF iLOD MODULE	44
LAMP CALIBRATION OF iLOD.....	45
SEAR IIi SETUP	46
SEAR IIi OPERATION	47
Verify Operation Of MTSS/Gate Tip/Bell Sensor:	47
Verify Operation of Ground Fault Testers (GFTs):.....	48
Verify Operation Of iLOD:.....	49
SEAR IIi Communication	49
SEAR IIi Alarms.....	49
TROUBLESHOOTING	51
SYSTEM STATUS INDICATORS AND LOGS.....	51
Detail View Track Status Window Color Scheme	51
Track Function Status.....	52
ISL and SSCC and System Status Indications.....	53
History Logs.....	54
Train History Log	54
Maintenance Log	54
Status Log.....	54
Summary Log	55
SYSTEM TROUBLESHOOTING.....	56
Diagnostics	56
System Diagnostics	57
Troubleshooting the Modules	57
SSCC IIIi Notes:	77

Lockout & Release Track	78
Diagnostics Log	78
Maintenance Call Lamp Output.....	78
Transfer Output	79
Troubleshooting Flowchart	80
TESTING TRACKSIDE EQUIPMENT	82
Testing Insulated Joint Couplers	82
Testing Rail Bonds	82
Testing Termination Shunts (Hardwire, Wideband and Narrow Band (NBS)).....	83
TESTING FOR TRACK CIRCUIT ISSUES	83
Track Circuit Problems	83
Low EX	83
Nuisance Activation – Rail Phase Check	84
Troubleshooting A De-energized Predictor	85
High EZ and Low EX History & Calibrated Approach	86
Troubleshooting A Physical 5000 GCP Input.....	87
Troubleshooting Maintenance Call (MC) Light Problems.....	90
OUT OF SERVICE FEATURE	93
Out of Service Inputs	95
Return Track to Service.....	95
VERSION REPORT.....	95
PROGRAMMING.....	96
PROGRAMMING THE MODEL 5000 GCP	96
PASSWORDS	97
LOGIN USING THE MAINTAINER PASSWORD	97
ATCS INFORMATION	98
ATCS Communication	98
Connecting Echelon® LONTALK Wiring.....	98
ATCS SITE ID ENTRY	100
UPLOAD SOFTWARE USING USB DEVICE	101
SET UP A USB DEVICE FOR USE	101
Creating the USB Device File Structure	102
INSTALLING SOFTWARE USING A USB DRIVE	104
A – Installing Software on CPU Module	104
B – Installing Software on CPU III Module	107
C – Installing Software on Track Module.....	111
D – Installing Software on RIO Module	112
E – Installing Software on SSCC IIIi Module	113
F – Installing Software on Display Module	114
G – Transfer Card, A80406 or A80468.	114
DOWNLOAD/UPLOAD CONFIGURATION (PAC) FILES VIA USB DEVICE	115
A – Download Configuration File To USB Drive....	115
B – Upload Configuration File To GCP	115
C – Checking CCN and OCCN.....	116
DOWNLOADING REPORTS AND LOGS	117
A – Download Configuration Report	117
B – Download GCP Logs.....	117
C – Download Train History.....	118
TRANSFER SEAR DATA VIA USB DEVICE	119
A – Installing Software on SEAR IIIi Module	119
B – CDL File Operations.....	119
C – Download SEAR Logs and Reports.....	120
D – EZ And EX Value Utilization	123
APPENDIX A – HARDWARE	125
CHASSIS CONFIGURATIONS	125
Common Chassis Components.....	125
Track Card Compatibility	125
CPU MODULE USER INTERFACE (A80403)	127
TRACK MODULE USER INTERFACE (A80418).....	132
DISPLAY MODULE, A80485-1	136

SOLID-STATE CROSSING CONTROLLER (SSCC IIIi)	
MODULE USER INTERFACE (A80405)	136
SSCC IIIi GENERAL INFORMATION	137
Unit Overview	137
Module Function Control	138
Crossing Controller Regulation for Lamp Voltage	
Outputs	138
Module Health	139
Battery Surge Protection and Power Wiring	139
Lighting Surge Panels	140
SSCC IIIi OPERATION.....	141
Failure Operation.....	141
Crossing Controller Module Installation.....	142
Crossing Controller Connectors	142
Lamp and Bell Wiring to the Lighting Surge Panel.....	144
Crossing Controller DC Power Connections	144
Connecting Power at Initial Cutover or After Changes	
to Warning Device Wiring.....	144
RELAY INPUT OUTPUT (RIO) MODULE USER	
INTERFACE (A80413).....	146
TRANSFER MODULES (A80406, A80468)	147
Transfer Module User Interfaces.....	147
Transfer Delay Interval Selection	150
Operation Without Transfer Module A80406.....	152
Operation Without Transfer Module A80468.....	152
APPENDIX B –REMOTE CALIBRATION AND	
CROSSING LAMP VOLTAGE ADJUSTMENT	154
REMOTE CALIBRATION EQUIPMENT	
REQUIREMENTS.....	154
SETUP SYSTEM FOR REMOTE CALIBRATION.....	155
REMOTE CALIBRATION OPERATIONS.....	155
Remote Calibration Setup	156
Enable Remote Calibration for Track	156
Remote GCP Calibration	157
Remote Approach and Linearization Calibration....	158
Remote Island Calibration	163
Remote Lamp Voltage Adjustments	164
Terminate Remote Calibration	166
REMOTE USER INTERFACE MENU	167
APPENDIX C – GLOSSARY	172

HOW TO USE THIS MANUAL

This handbook is intended to provide guidance to maintenance personnel. Information is provided in the indicated locations for the listed purpose:

System Cutover	Page 5
Calibration	Page 11
Operational Checks	Page 37
Troubleshooting	Page 51

WARNING

Railroads or agencies are responsible for ensuring only properly trained and authorized personnel have access to the model 5000 GCP.

Warning devices may not operate as intended during installation, cutover, module change out, module software updates, reboot and calibration procedures. Take alternate means to warn vehicular traffic, pedestrians, and employees.

Before placing the model 5000 GCP into service following installation, programming change, hardware changes, or wiring changes:

Verify tracks are free of any and all track related issues.

Verify the proper components are used, wired, and programmed as specified by the railroad's or agency's approved wiring/installation diagrams and procedures.

Verify complete system operation as specified by the railroad's or agency's test procedures.

Failure to follow these guidelines may lead to incorrect or unsafe operation of the track circuit.

SYSTEM CUTOVER

NOTE

This procedure does not supersede procedures of the maintaining railroad. This procedure is designed to supplement railroad procedures. In case of conflicts between procedures, the most restrictive procedure should govern.

MODEL 5000 GCP SYSTEM CUTOVER FORM

The GCP System Cutover Form, SIG-00-08-14:

- Is used when installing, physically modifying, or after disarrangement of a Model 5000 GCP.
- Includes the SEAR Ili and the SEAR Ili appliances.

Equipment Needed:

- Hardwire test shunt & 0.06 ohm test shunt
- Stop watch
- Model 5000 GCP Display module (A80485-1), or Web User Interface (WebUI).
- Voltmeter – True-RMS AC and AC + DC measurements, J-type and K-type temperature measurements, 20 MHz frequency counter, or a conventional voltmeter, which requires use of the conversion chart found in Table 15.

⚠ WARNING

The SSCC IIIi modules shall be secured with the built-in screw fasteners.

Gates will descend immediately (without gate delay) and the lights will not activate when the SSCC IIIi is removed.

⚠ CAUTION

Disconnect the lamp load at the surge panel before removing or inserting SSCC IIIi modules.

NOTE

Modules may be removed and/or replaced from the case without removing power. In regards to A80405 SSCC IIIi Modules, see Warning above.

WIRING OF KEYED INTERFACE CONNECTORS

⚠ WARNING

Incorrect wiring and installation will lead to unsafe functioning of the GCP. The user must follow correct installation procedures and perform installation testing to verify correctness of the wiring and system programming parameters before placing the GCP in service.

External Wiring Connectors and Wire Size

All external wiring to a Model 5000 GCP Assembly is by means of plug-in connectors.

The orange cage-clamp connectors for the signal circuits should use 16 to 12 AWG wire.

The orange cage-clamp connector for the Echelon LON Talk should use communication grade twisted wires of at least 20 AWG.

The green Screw-Lock connectors for the CPU and the SSCC should use 10 AWG wire.

Table 1: AWG to mm² Conversion

AWG	mm ²
20	0.50
18	0.75
17	1.0
16	1.5
14	2.5
12	4.0
10	6.0
8	10

Wire Preparation

Strip insulation from the end of the wire as indicated in Figure 1 below.

Table 2: Wire Strip Lengths by Connector

Type of Connection	Strip Length
Screw-down	0.28" (7 mm)
Cage clamp	0.32" – 0.35" (8 – 9 mm)

It is recommended that a stripping tool be used which allows the strip length to be set accurately. The addition of ferrules is not required. Prepare all wires in this fashion.

Wire Insertion

For screw-down type connectors:

- Insert stripped end of a wire into the wire receptor of the connector until it stops.
- Verify that no portion of the wire insulation is in contact with the wire receptor.
- Tighten screw to a torque of 4.5 inch pounds (0.5 – 0.6 Nm). (About the same tightness as required when tightening a signal terminal nut.)
- Pull on wire to determine that it does not move within the connector. (Pull with about the same amount of force as when tightening boot laces.)
- If a wire is suspected of moving when pulled, remove the wire and run the wire receptor through its full range of motion. Repeat the above steps for this wire.
- Repeat the above steps for each wire being attached to the connector.

If any wire receptor fails to hold the wire securely, replace the screw-type connector with an appropriate cage-clamp style connector.

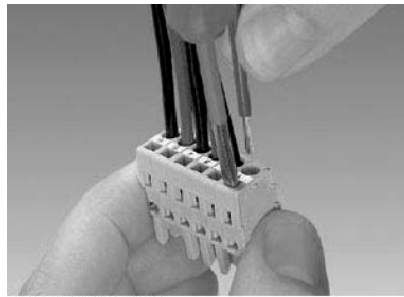

MWS_08-06_WIRE_INSERT
04-15-08

Figure 1: Inserting Wire in Cage Clamp Type Connector

CAUTION

Use the correct screwdriver size to prevent damage to the connector.

NOTE

The recommended flat-bladed screwdriver blade size is 0.10" wide, 0.020" thick (2.5mm x 0.5mm).

For cage clamp type connectors:

- Insert blade of appropriate sized flat bladed screwdriver in rectangular slot in connector next to the wire receptor (see Figure 1).
- Lever the wire cage clamp open by pressing straight down on the screwdriver.
- Insert the stripped end of a wire into the fully-open wire receptor until it stops.

Hold the wire in place and remove the screwdriver blade from the slot. The wire clamp closes down on the stripped end of the wire.

CIRCUIT AND PROGRAMMING VERIFICATION

Verify the Model 5000 GCP modules shown on the circuit plans are properly inserted and secured into their appropriate slots (main/standby).

NOTE

The main and standby modules do not require independent programming. Both sets of modules operate from the same stored application program.

STEP 1

- Remove all connectors (green screw type and orange cage-clamp) to the Model 5000 GCP.
- Close battery buss to Model 5000 GCP system case.
- Verify the voltage and polarity of the B and N wiring to the Green plug connectors for the GCP and SSCC.
- Insert only the Green power plug connector above the CPU module and verify programming after system boots.

NOTE

The CPU reboot will take approximately 3 minutes to cycle.

- If used, set the Model 5000 GCP Transfer Timer Module 80406 or Transfer Timer Assembly 80468 timer transfer switch to MAIN.
- Review the program in the Model 5000 GCP by selecting **2) GCP Programming** from the Program View menu and verify the programming via the Main Program Menu's submenus. The checksums (OCCN, CCN, and FCN) can also be verified via the Program View screen.
- Verify the programming per the approved site drawing, adding field measured parameters (approach, DAX offset and island distances, etc.).
- Use the Back key to navigate to Program View. Verify that the OCCN, CCN, and FCN against the site drawing and note the values on the System Cutover Form.
- Select **1) Site Configuration**. The Site Configuration screen appears.
- If required, enter any data needed so that all parameters match the approved site drawing.

NOTE

The CPU will reboot when any changes are made to the ATCS address.

STEP 2

- If used, verify the Echelon LAN wiring and termination is in place.
 - Before connecting power to other GCP connectors, verify wiring to Model 5000 GCP system, case wiring, wiring to surge panels, track, warning devices, and cable circuits to other locations.
- Connect track cable at house termination points.
- Connect other cable circuits at house termination points.

⚠ WARNING

During the SSCC IIIi boot-up process and after all wiring is connected:

The crossing gates will be down with crossing lamps flashing and bells ringing.

The A80405 module(s) will not be responsive to crossing control input from the model 5000 GCP.

Take adequate precautions to warn any pedestrians, personnel, trains, and vehicles in the area until proper system operation is verified.

⚠ CAUTION

The SSCC IIIi module has active internal short circuit protection for lamp, bell, and gate control outputs that is effective only after the SSCC IIIi has booted up. Therefore, at the initial cutover, it is important to boot up the system prior to connecting external loads.

See connection sequence below in Step 3. Do not insert the model 5000 GCP SSCC IIIi green connectors for B, N, L1, L2, GCs, bells, and inputs until directed to do so at the proper step. Do not close the lamp, gate control, GP/GD, or bell inputs until the module health LED is flashing at a 1 Hz rate, indicating that the module is healthy and ready for operation.

STEP 3

The SSCC IIIi connectors and wiring to loads must be applied in the following sequence to avoid damage:

- Open the lamp, gate GC control, GP inputs, GD inputs and bell circuits at the surge panel(s).
- Verify battery polarity on Green power plugs and Orange input plug connector(s).
- Connect the screw-lock power connector for each SSCC IIIi module and lock by tightening screws.
- Wait approximately 40 seconds for SSCC IIIi module(s) to boot up.
- Connect the GC/bell and GP/GD Orange Input cage-clamp plug connectors to the appropriate SSCC IIIi.
- Close the lamp, gate control, GP/GD inputs and bell circuits on the surge panel(s).
- Connect warning device wiring and cables at house termination points.
- Connect all other connectors to Model 5000 GCP system.
- Connect all other electronic equipment to the battery busses.

AUXILIARY EQUIPMENT CONNECTION AND SETUP

Typical peripheral equipment used on the Model 5000 GCP is depicted below:

- Ethernet Spread Spectrum Radio (ESSR), 53325,53350, & 53355
- Siemens Event Analyzer/Recorder (SEAR) Accessory Group, which is comprised of:
 - Mini Trackage Sensor Package (MTSS)
 - VHF Communicator, A80276
 - Ground Fault Tester 2, A81010 (GFT-2)
 - Intelligent Light Out Detector, A80271 (iLOD)

Ethernet Spread Spectrum Radio (ESSR)

Install and program ESSR per the model-specific manual. Radio version is specified in the approved site drawing. Since the ESSR can plug directly into the GCP 5000's Ethernet port, a Wayside Access Gateway (WAG) is not required. The RJ-45 connector on the end of the CAT5 power/data cable is plugged into the ESSR port located next to the connectors for SSCC-2 on the top of the system case.

MAINTENANCE CALL (MC) LIGHT

If this feature is used:

Verify that the MC light is illuminated.

Verify that the MC extinguishes when:

- If used, the MAINT CALL RPT Input de-energizes (observe input on I/O view).
 - The MAINT CALL RPT input is restored and the MC illuminates.
- Power-off relay is used to control the MC light
- POK relay de-energizes
 - Restore POK relay and MC lights.

NOTE

LEDs and Display indications on Maintenance Call indicate the health of the system, which indicate ON when healthy and OFF when unhealthy, which is opposite of the physical Maintenance Call lamp.

VERIFY OFFICE CONFIGURATION CHECK NUMBER

There are two methods to validate the office configuration check number is per the circuit plan. Either:

- Scroll to Program View and review the numbers presented

or

- From the System View screen, scroll left or right to the Diags & Reports screen
- When the Diags & Reports screen opens, select **3) Logs & Report > 1) Reports > 7) Check Numbers.**

This completes the Model 5000 GCP system check out procedure.

CALIBRATION

The Model 5000 GCP is programmed through the use of the A80485-1 Display module or by the Web User Interface (WebUI).

Model 5000 GCP System Calibration consists of GCP calibration, SSCC lamp adjustment, and system checkout.

WARNING

If island status is changed from No to Internal, island recalibration may be required.

NOTE

If the CPU module MCF or the Track Module MEF are changed, requisite programming and recalibration will be required.

RECALIBRATION & REPROGRAMMING REQUIREMENTS DUE TO MODULE REPLACEMENT

The recalibration requirements due to the replacement of a module are shown in the following table.

Table 3: Recalibration & Reprogramming Requirements Due to Module/Chassis Replacements

Module /Assembly Replacement		Calibration Required				Reprogramming Required
		GCP CAL	GCP APP	GCP LIN	ISL CAL	
A80403	CPU II+	No	No	No	No	No
A80903	CPU III	No	No	No	No	No
A80418	Track	Yes ¹	Yes/No ²	Yes/No ²	Yes	No
A80413	RIO (I/O)	No	No	No	No	No
A80406	Transfer	No	No	No	No	No
A80405	SSCC ³	No	No	No	No	No
A80485-1	Display	No	No	No	No	No
A80410	SEAR	No	No	No	No	N/A ⁴
A80435	SPI ECD ⁵	No	No	No	No	No
A53555	USB ECD	No	No	No	No	No
n/a	Chassis	Yes	Yes	Yes	Yes	Yes

Notes:

1. For track with changed A80418.
2. May be bypassed using BYPASS button instead of the START button in calibration procedure.
3. SSCC lamp voltages must be readjusted
4. Site Setup required.
5. Plug-in located on chassis behind Display module. Requires same MCF as previously in use.

RECALIBRATION REQUIREMENTS DUE TO PROGRAM CHANGES

The GCP program changes that require track recalibration are indicated in the following table.

Table 4: Recalibration Requirements Due to Program Changes

Program Changes	Calibration Required				Reprogramming Required
	GCP CAL	GCP APP	GCP LIN	ISL CAL	
Increased Number of Tracks	Yes ¹	Yes ¹	Yes ¹	Yes ²	Yes ¹
GCP Frequency Change	Yes ³	Yes ³	Yes ³	No	No
Island Frequency change	No	No	No	Yes ⁴	No
Application changed: Unidirectional to Bidirectional, Bidirectional to Unidirectional or Unidirectional to Simulated Bidirectional	Yes ⁵	Yes ⁵	Yes ⁵	No	No
Transmit Level Changed					
Approach Distance Changed					
Ballast Compensation Value Changed					
Island Operation Changed from No to Internal or from Internal to No	Yes ⁶	No ⁷	No ⁷	Yes ⁸	No
Template Changed	Yes ⁹	Yes ⁹	Yes ⁹	Yes ⁹	Yes ¹⁰
Template Set To Default selected					
New Software Installed					
Notes: 1. For added tracks only 2. If island is used 3. For tracks with new GCP frequencies 4. For tracks with new island frequencies 5. For changed tracks only 6. If EZ varies more than 2 7. Can be bypassed 8. If changed to internal 9. For all tracks 10. Complete re-programming required NOTE: Uploading a new PAC may require re-calibration					

RECALIBRATION REQUIREMENTS DUE TO TRACK EQUIPMENT CHANGES

Changes made to the existing track equipment that require track recalibration are shown in the following table.

Table 5: Recalibration Requirements Due To Track Equipment Changes				
Track Equipment Changes	Calibration Required			
	GCP CAL	GCP APP	GCP LIN	ISL CAL
Termination Shunts Changed	Yes ¹	No ³	No ³	No
Termination Shunts Moved to New Location	Yes ¹	Yes ¹	Yes ¹	No
Change of shunt or frequency in overlapping territory	Yes ¹	Yes ¹	Yes ¹	No
Termination Shunts of Other Frequencies Added, Removed From, or Moved Within the 5000 GCP Approaches)	Yes ¹	Yes ¹	Yes ¹	No
Wide band Insulated Joint Couplers (8A076 or 8A077) Replaced in 5000 GCP Approaches)	Yes ¹	No ^{2, 3}	No ^{2, 3}	No
Tuned Insulated Joint Couplers (62785-f) Replaced in 5000 GCP Approaches)	Yes ¹	Yes ¹	Yes ¹	No
5000 GCP Track Wire(s) Replaced, Disarranged, and/or Modified	Yes ¹	No ^{2, 3}	Yes	Yes
Change of Insulated Joint Bypass Coupler (Tuned) 7A422-f	No	No	No	No
Notes: 1. For changed tracks only. 2. Requires bypass. 3. If, after completing maintenance and reconnecting Track Wires, the EZ/EX returns to the previous value, approach or linearization recalibrations are not required. But if the values are different, recalibrate the approach or linearization.				

NOTE

Approach distance in the Program menu must be changed to reflect the new approach distance prior to start of track calibration. Otherwise, the system will prompt for recalibration.

CALIBRATION PROCEDURES

⚠ WARNING

GCP tracks must be verified to be free of any and all track related issues prior to being placed in service. Any track related issues that are identified must be corrected and verified to be correct prior to final calibration and linearization.

NOTE

If the outlined procedures fail, they should be repeated once. If the error repeats, refer to the Troubleshooting section.

GCP calibration is divided into the following procedures:

- Tuning the Tuned Joint Coupler (TJC)
- GCP Calibration (GCP)
- Approach Distance Calibration (Approach)
- Linearization Steps Calibration (Linearization)
- Island Calibration (Island)

⚠ WARNING

The approach and linearization procedures require the recording of the computed approach distances in feet or meters (not the EZ value).

When editing the computed approach distances, enter the value in feet or meters (not the EZ value).

Failure to enter distances in feet or meters may result in shorter warning times than intended.

Perform the following tuning procedures on the tuned joint coupler after calibrating the track and prior to beginning the linearization process.

Tuning the 62785-f Tuned Joint Coupler

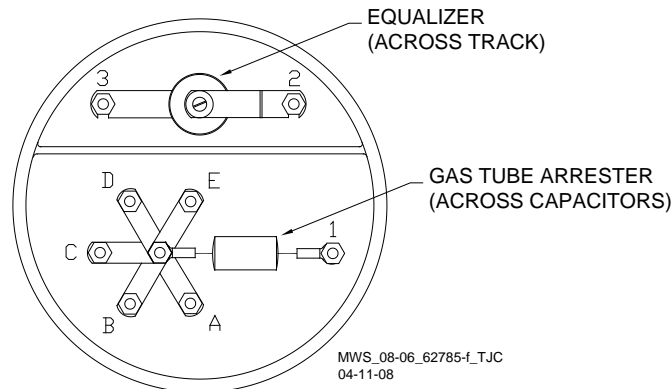

Figure 2: Tuned Joint Coupler, 62785-f

The Tunable Insulated Joint Bypass Coupler, 62785-f is the only tuned bypass coupler to be used with the Model 5000 GCP for bypassing insulated joints in DC coded track.

- The 62785-f Bypass Coupler is used in all 5000 GCP applications requiring the use of a tuned insulated joint bypass coupler.
- The 62785-f Coupler is available in standard Siemens frequencies of 114 Hz through 970 Hz.

⚠ WARNING

The tuned joint coupler must be tuned prior to performing setup for approach length and linearization procedures during the track calibration process.

62785-f tuned bypass couplers must only be used to bypass insulated joints in coded or non-coded DC track circuits.

The application guidelines for Tunable Insulated Joint Bypass Coupler, 62785-f when used only with the 5000 GCP have been expanded as follows:

- In DC coded track circuits, the insulated joints within an approach may be bypassed using the Siemens 62785-f Tunable Insulated Joint Bypass Coupler, provided the minimum distances specified in Table 6 are observed.
- The 62785-f Coupler must be field tuned to pass the 5000 GCP operating frequency (f) around insulated joints in DC or coded DC track circuits.
- Field tuning of the Coupler enables precise frequency adjustment for track and joint parameters.
- The Coupler must be located within 10 ft. (3 m) of the insulated joints that it is coupling.
- The minimum distance to the insulated joints is generally a function of the 5000 GCP operating frequency; i.e., the lower the operating frequency, the longer the minimum distance.

Two sets of insulated joints may be coupled in any single approach, provided the minimum operating distances specified in Table 6 are observed.

- Table 6 indicates the minimum operating distances (in feet/meters) to the first and second set of insulated joints that are coupled with 62785-f couplers for 5000 GCP operation.

⚠ WARNING

At the completion of field tuning the 62785-f bypass couplers, ensure that a standard AREMA nut is tightened securely against each gold nut on terminals a through e, including the terminals that are not tightened down.

NOTE

While field tuning the 62785-f Bypass Coupler, tightening the nut on terminal E produces maximum change in EZ value. Tightening the nut on terminal A produces minimum change.

The 62785-f Coupler is tuned by means of five standard AREMA binding posts:

- AREMA binding posts are labeled A through E (see Figure 2)
- AREMA binding posts are equipped with special gold AREMA adjustment nuts

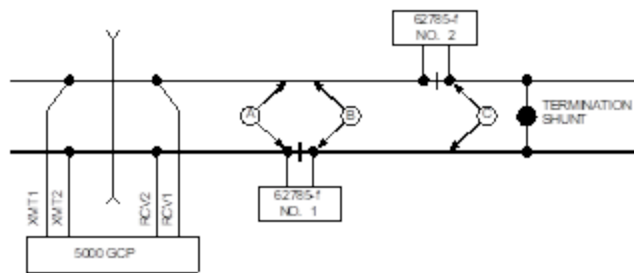

Staggered Insulated Joints

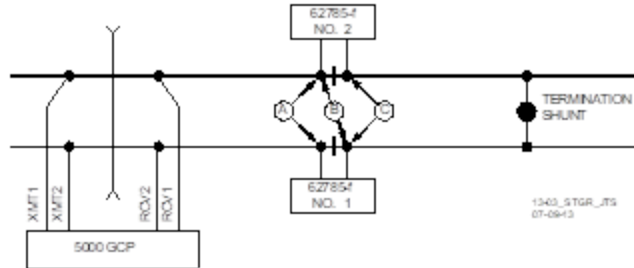

Non-Staggered Insulated Joints

Figure 3: Shunt Placement For 62785f Bypass Coupler

Table 6: Tuned Joint Coupler, 62785-f Minimum Distances

Frequency (Hz)	Minimum Distance to 1 st Set of Insulated Joints (Feet/Meters)*	Minimum Distance to 2 nd Set of Insulated Joints (Feet/Meters)*
151 to 211	1500/457	2200/671
212 to 348	1000/305	1400/427
349 to 560	700/213	1000/305
561 to 790	500/152	800/244
791 to 979	400/122	700/213

* Distance applies to insulated joints located on the same side of the crossing.
 NOTE: Frequencies of 86 and 114 Hz are not normally used with the 62785-f coupler. Contact Siemens Mobility, Inc Technical Support (1-800-793-7233) for these applications.

Table 7: Method 1 for Tuning the 62785-f Tuned Joint Coupler

See Figure 3 above for locations referred to in this table.	
Step 1	Remove each coupler's end cap and tighten the gold nut securely on terminal E of each coupler. Loosen the nuts on terminals D, C, B, and A.
Step 2	Calibrate the 5000 GCP, setting the EZ value to 100 (see Table 9).
Step 3	Place a hardwire test shunt across the track at location A (Figure 3.)
Step 4	Note the EZ value appearing on the 5000 GCP Display module.
Step 5	Move the test shunt to location B.
Step 6	<p>Tune the Tunable Insulated Joint Bypass Coupler #1 to the same EZ value noted in Step 4.</p> <p>Tighten the gold nut on the Coupler #1 terminals labeled D, C, B, and A, in sequence beginning with terminal D.</p> <p>If tightening a nut results in an EZ value that is lower than the value recorded in Step 4, loosen the nut and tighten the next nut in sequence.</p> <p>If, after tightening a nut, the EZ value remains higher than the value recorded in step 4, leave the nut tightened and tighten the next nut in sequence.</p> <p>Continue to tighten nuts D through A as necessary to obtain an EZ value that is approximately the same as that recorded in Step 4.</p>
<pre> graph TD Start([Get Ez_Current]) --> D1{Is Ez_Current = Ez_Required ± 1?} D1 -- Yes --> End([End]) D1 -- No --> D2{Is Ez_Current > Ez_Required?} D2 -- Yes --> A1[Arrange links to decrease Ez] A1 --> Start D2 -- No --> A2[Arrange links to increase Ez] A2 --> Start </pre>	
Step 7	Move the test shunt to location C.
Step 8	<p>Tune the No. 2 Tunable Insulated Joint Bypass Coupler to the EZ value noted in Step 4. Tighten the gold nut on the Coupler #2 terminals labeled D, C, B, and A, in sequence beginning with terminal D. If tightening a nut results in an EZ value that is lower than the value recorded in Step 4, loosen the nut and tighten the next nut in sequence. If, after tightening a nut, the EZ value remains higher than the value recorded in Step 4, leave the nut tightened and tighten the next nut in sequence. Continue to tighten nuts D through A as necessary to obtain an EZ value that is approximately the same as that recorded in Step 4.</p>

Table 7: Method 1 for Tuning the 62785-f Tuned Joint Coupler

Step 9	Remove the test shunt.
Step 10	Tighten a standard AREMA nut against each gold nut of both couplers to ensure all nuts are securely locked in position.
Step 11	Secure the end caps over the terminal end of both couplers.
Step 12	Completely recalibrate the 5000 GCP and perform all operational checks.
Step 13	Verify that a smooth change in the EZ value occurs across the couplers during a train move.

Table 8: Method 2 for Tuning the 62785-f Tuned Joint Coupler

See Figure 3 above for locations referred to in this table.	
Step 1	Tighten the gold nut securely on terminal E of each coupler.
Step 2	Calibrate the 5000 GCP, setting the EZ value to 100.
Step 3	Place a hardwire test shunt across the track at location A.
Step 4	Note the EZ and EX values appearing on the 5000 GCP Display module.
Step 5	Move the test shunt to location B.
Step 6	Tune the Tunable Insulated Joint Bypass Coupler #1 EX value to above 75. The EZ value may be as much as 8 points above the value noted in Step 4.
Step 7	Move the test shunt to location C.
Step 8	Tune the Tunable Insulated Joint Bypass Coupler #2 EX value to above 75. The EZ value may be as much as 16 points above the value noted in Step 4.
Step 9	Remove the test shunt.
Step 10	Tighten a standard AREMA nut against each gold nut of both couplers to ensure all nuts are securely locked in position.
Step 11	Secure the end caps over the terminal end of both couplers.
Step 12	Completely recalibrate the 5000 GCP and perform all operational checks.
Step 13	Verify that a smooth change in the EZ value occurs across the couplers during a train move.

Calibrating a Track Module



Do not recalibrate if an in-service track suddenly has a large jump in EZ or high signal error. The cause may be a track, bond, coupler or shunt related problem which must be investigated and corrected before considering recalibration. Before starting calibration, ensure that track bonding is good, that all termination shunts, insulated joint couplers, and track isolation devices are installed and that no trains are in the GCP approaches.

NOTE

During approach calibration of the Model 5000 GCP, when the island is de-energized, the EX value is locked to 100. During a new installation, an upgrade, or a Track Card replacement, with the EX locked at 100 the EZ may appear abnormally low. Once the island is energized, the EX unlocks and the EX and EZ display actual approach values based upon field conditions. The island for a given track module does not necessarily have to be on that particular module (or any module if an external island), depending upon circuit arrangement.

Track Module calibration is required if the Display module's:

- Track Detail screen depicts:
 - the GCP with Calib Req
 - the Island with Calib Req
- Calibration screens depict:
 - GCP Calib Req
 - Approach Calib Req
 - Linearization Calib Req
 - Island Calib Req
- During calibration, the Track Module 4-character display shows one of the following:
 - GCAL – GCP Calibration in process
 - GAPP – Approach Calibration in process
 - GLIN – Linearization Calibration in process
 - ICAL – Island Calibration in process

The Calibration screen indicates which calibrations are required with an empty box in each calibration select button. A check mark is displayed in the box when the indicated calibration is complete.

Table 9: GCP Calibration

Step 1	If system has a transfer module, set the transfer switch to MAIN .
Step 2	If a 60 or 100 Hz Cab Signal is in use, turn it off at this time.
Step 3	From the System View menu, select the track to calibrate, i.e., 1 – 6 by entering that number on the keypad. The menu shows only enabled tracks.
Step 4	From the Track Options menu, select 3) Calibration . The Track “N” Window appears, depicting the Calibration status of: 1) GCP, along with EZ and EX values 2) Approach, along with Computed Distance 3) Linearization, along with Linearization Steps 4) Island, along with Island Status and Z Level If Calib Required appears on any of the above lines, calibration is required.

Table 9: GCP Calibration

<p>Step 5</p>	<p>Select 1) GCP. The Track “N” GCP Calibration Window opens, listing 1) Start Calibration and 2) Add Comment. Use the Add Comment option to add a reason for calibration or re-calibration. Select 1) Start Calibration. The Display module depicts Initiating, then In Progress messages during the calibration. If calibration is successful:</p> <ul style="list-style-type: none"> • Passed, please wait appears in the window. • EZ should be 98 to 102 and the 1) GCP line has a green check next to Calibrated. <p>If calibration is not successful, the Display module shows a Failed message.</p>
<p>Step 6</p>	<p>To record the reason for the recalibration in the Maintenance log, select 3) Calibration.</p> <ul style="list-style-type: none"> • The Track “N” Window appears. • Select 2) Add Comment. • On the Enter Text tile, type any notes concerning the reason and select Enter.
<p>Step 7</p>	<p>If the cab signal was turned off in Step 2, turn it on.</p>

The linearization procedure compensates for lumped loads in the Model 5000 GCP approach that can affect the linearity of EZ over the length of the approach as a train approaches the crossing. The linearization is essential to improving warning time accuracy. Linearization may be affected by: narrow band shunts in other frequencies, which may occur when other GCP approaches overlap the GCP approach circuit; other track equipment in the GCP approach such as audio frequency overly track circuits, coded track circuits, etc.; and missing or incorrect track battery chokes.

⚠ WARNING

Use the following bypass procedure only if the current computed approach distance and linearization values are known to be correct.

NOTE

If an in-service 5000 GCP requires only that the GCP Calibration procedure be performed, the BYPASS procedure must be completed for both Approach and Linearization.

Table 10: Approach & Linearization Calibration Bypass Procedure

<p>Step 1</p>	<p>Once GCP Calibration is completed, bypass the approach calibration by first selecting 2) Approach. After the Track “N” Approach Calibration Window opens, select 3) Bypass. Do not select 1) Start Calibration.</p>
<p>Step 2</p>	<p>Bypass the linearization calibration by first 2) Approach. After the Track “N” Linearization Calibration Window opens, select 3) Bypass. Do not select 1) Start Calibration.</p>

WARNING

The approach and linearization procedures require the recording of the computed approach distances in feet or meters (not the EZ value). Failure to enter distances in feet or meters may result in shorter warning times than intended.

NOTE

Calibration Distance and Linearization Steps values are site historical data and must be recorded as specified in Table 11 in Figure 5 & 6 in this manual as well as in Figures 1 & 2 on both the History Card and the Site Cutover form.

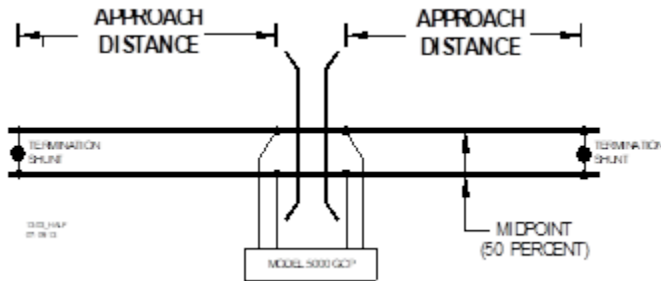

Figure 4: Midpoint Location (See Step 6 below)

Table 11: Approach Distance and Linearization Calibration

Step 1	Record the EZ and EX values for the track (before installing hardwire shunt) in the Step 1 and Step 2 column (Calibrated Values) on Figure 5 found on Page 24. Then, temporarily place a hardwire shunt across the termination shunt. For bidirectional installations, use the termination shunt furthest from the crossing.
Step 2	Record the EZ and EX values for the track in the First Approach, Step 2 column on Figure 5.
Step 3	Select 2) Approach . The Track "N" Approach Calibration Window opens, listing 1) Start Calibration, 2) Edit and 3) Add Comment .
Step 4	Select 1) Start Calibration . The Display module reports Initiating , then In Progress during the calibration. If calibration is successful: <ul style="list-style-type: none"> • Passed, please wait appears in the window, followed by Calibrated. • The Computed Distance value appears and the 2) Approach line has a green check next to Calibrated. If calibration is not successful, the Display module shows a Failed message.
Step 5	Record the computed approach distance in feet or meters for the track in the First Approach, Step 5 column (Computed Distance) on Figure 5

Table 11: Approach Distance and Linearization Calibration

Step 6	Accurately (within 1%) locate the midpoint of the longest approach and move the hardwire shunt to that point on the rails. Note: Fit studs to rail at this point to enable low resistance connection.
Step 7	Select 3) Linearization . The Track “N” Linearization Calibration Window opens, listing 1) Start Calibration, 2) Edit, 3) Bypass and 4) Add Comment .
Step 8	Select 1) Start Calibration . The Display module reports Initiating , then In Progress during the calibration. If calibration is successful: <ul style="list-style-type: none"> • Passed, please wait appears in the window, followed by Calibrated. • The Linearization Steps value appears and the 3) Linearization line has a green check next to Calibrated. If calibration is not successful, the Display module shows a Failed message.
Step 9	Record the linearization step value for the track in the First Approach, Step 9 column (Linearization Steps) on Figure 5 found on Page 24. The value should be between 68 and 132. If not, refer to Troubleshooting, found beginning on Page 51.
Step 10	Verify that the computed approach distance in feet or meters (Computed Distance, Step 5) and the linearization steps (Linearization Steps, Step 9) values recorded Figure 5 are the same as the values displayed on the Track “N” window.
Step 11	Remove the hardwire shunt from the track.
Step 12	If the approach is unidirectional or simulated bidirectional, go to step 31. If the track is bidirectional and the measured distance to the other termination shunt is within 10 % of the first approach distance, go to step 13. If the distance is clearly shorter, go to step 31.
Step 13	Temporarily place a hardwire shunt across the termination shunt of the other approach.
Step 14	Record the EZ and EX values for the track in the Second Approach, Step 14 column Figure 6 found on Page 25.
Step 15	Select 2) Approach . The Track “N” Approach Calibration Window opens, listing 1) Start Calibration, 2) Edit and 3) Add Comment .

Table 11: Approach Distance and Linearization Calibration

Step 16	<p>Select 1) Start Calibration. The Display module reports Initiating, then In Progress during the calibration.</p> <p>If calibration is successful:</p> <ul style="list-style-type: none"> • Passed, please wait appears in the window, followed by Calibrated. • The Computed Distance value appears and the 2) Approach line has a green check next to Calibrated. <p>If calibration is not successful, the Display module shows a Failed message.</p>
Step 17	<p>Record the computed approach distance in feet or meters in the Second Approach, Step 17 column on Figure 6.</p>
Step 18	<p>Accurately (within 1%) locate the midpoint of this approach and move the hardwire shunt to that point on the rails.</p>
Step 19	<p>Select 3) Linearization. The Track “N” Linearization Calibration Window opens, listing 1) Start Calibration, 2) Edit, 3) Bypass and 4) Add Comment</p>
Step 20	<p>Select 1) Start Calibration. The Display module reports Initiating, then In Progress during the calibration.</p> <p>If calibration is successful:</p> <ul style="list-style-type: none"> • Passed, please wait appears in the window, followed by Calibrated. • The Linearization Steps value appears and the 2) Approach line has a green check next to Calibrated. <p>If calibration is not successful, the display shows a Failed message.</p>
Step 21	<p>Record the linearization (Linearization Steps) value (between 68 and 132) for the track in the Second Approach, Step 21 column (Linearization Steps) on Figure 6 found on Page 25.</p> <p>Verify that the computed approach distance in feet or meters (Computed Distance, Step 17) and the linearization steps (Linearization Steps, Step 21) values recorded are the same as the values displayed on the Calibration Select window.</p>
Step 22	<p>Remove the hardwire shunt from the track.</p>
Step 23	<p>If the Linearization Steps value for the second approach (Figure 6, Step 21) is greater than or the same as the Linearization Steps value recorded for the first approach (Figure 5, Step 9), go to Step 31.</p> <p>If the Linearization Steps value for the second approach (Figure 6, Step 21) is less than the value recorded for the first approach (Figure 5, Step 9), go to Step 24.</p>
Step 24	<p>Select 3) Linearization. The Track “N” Linearization Calibration Window opens, listing 1) Start Calibration, 2) Edit, and 3) Add Comment</p>
Step 25	<p>Select 2) Edit</p> <ul style="list-style-type: none"> • The New value dialog box appears.

Table 11: Approach Distance and Linearization Calibration

Step 26	Enter the Linearization Steps value recorded on Figure 5 for the first approach (Step 9) into the New Value field using the keypad numbers and select ENTER . <ul style="list-style-type: none"> The entered value appears on 3) Linearization.
Step 27	Select 2) Approach . The Track “N” Approach Calibration Window opens, listing 1) Start Calibration, 2) Edit and 3) Add Comment .
Step 28	Select 2) Edit . The New value dialog box appears.
Step 29	Enter the computed approach distance value recorded for the first approach (Figure 5, Step 5) into the New Value field using the keypad numbers and select ENTER . <ul style="list-style-type: none"> The entered value appears on 2) Approach.
Step 30	Verify that the computed approach distance (Computed Distance , Step 5) and the linearization steps (Linearization Steps , Step 9) values recorded on Figure 5 for the first approach are the same as those displayed on the Track “N” window.
Step 31	Transfer the information written in Figure 5 and Figure 6 below onto Figure 1 and Figure 2 of the Model 5000 GCP Application History Card, SIG-00-04-21 and Figure 1 and Figure 2 of the Model 5000 GCP System Cutover Test Procedure and Check Off Sheet, both of which are found at the back of the Model 5000 GCP Family Application Guidelines Manual, SIG-00-13-03. If the initial settings of the GCP were changed or equipment changes were made such that require recalibration of the GCP, Approach, and Linearization, place the updated Computed Distance and Linearization Steps data in Figure 3 and Figure 4 of the History Card.
Step 32	To record the reason for the Calibration and store it in the Maintenance log, select 3) Linearization and then 3) Add Comment . <ul style="list-style-type: none"> Type any notes about the calibration and select Enter to save the entry.

	Calibrated Values (Step 1)		1 st Approach E/W ()			
			N/S ()			
	EZ	EX	Hardwire Across Termination Shunt (Step 2)		Computed Approach Distance (Ft/m) (Computed Distance) (Step 5)	Linearization Step Value (Linearization Steps) (Step 9)
Track 1			EZ	EX		
Track 2						
Track 3						
Track 4						
Track 5						
Track 6						

Figure 5: Calibration Value History Form, 1st Approach

			2nd Approach E/W () N/S ()			
	Calibrated Values (Step 1)		Hardwire Across Termination Shunt (Step 14)		Computed Approach Distance (Ft/m) (Computed Distance) (Step 17)	Linearization Step Value (Linearization Steps) (Step 21)
	EZ	EX	EZ	EX		
Track 1						
Track 2						
Track 3						
Track 4						
Track 5						
Track 6						

Figure 6: Calibration Value History Form 2nd Approach

NOTE

This completes Approach and Linearization Calibration. If the system includes an internal island, proceed to Island Calibration (Island). If not, proceed to Table 14. The island can be calibrated to respond to a shunting sensitivity of 0.12, 0.3, 0.4, or 0.5 ohms. A hardwire shunt is used for calibration.

NOTE

Island track circuit calibration is generally performed using 0.12 ohm shunting sensitivity. In an area where poor shunting is experienced or anticipated, a minimum of 0.3 ohm shunting sensitivity is recommended.

In areas of passenger operation, a minimum of 0.3 ohm shunting sensitivity is recommended.

Table 12: Island Calibration

Step 1	<p>If an Island circuit is used, select 3) Island.</p> <ul style="list-style-type: none"> The ISLAND CALIBRATION Window appears.
Step 2	<p>Temporarily install a hardwire shunt beyond the island receiver rail connections at the appropriate distance specified below the Calibration Required message.</p> <ul style="list-style-type: none"> Shunt distances for island frequencies are provided in the table following the Island Calibration procedure. Ensure EZ value is less than or equal to 5. See Figure 7

Table 12: Island Calibration

<p>Step 3</p>	<p>Select 1) Start Calibration. The Display module reports Initiating, then In Progress during the calibration.</p> <p>If calibration is successful:</p> <ul style="list-style-type: none"> • Passed, please wait appears in the window, followed by Calibrated. • The Z Level value appears and the 4) Island line has a green check next to Calibrated. • If calibration is not successful, the Display module shows a Failed message (see Troubleshooting). • Place a hardwire shunt / jumper across the track receiver terminals on the terminal board. • Return to Track Detail View (see Figure 7). Ensure the Island Z value is less than 40. If the value is greater than 40, repeat calibration Steps 2 and 3. If the Z value is still greater than 40, REMOVE THE TRACK MODULE FROM SERVICE.
<p>Step 4</p>	<p>Verify that the Island indicator on the 4) Island line is grey and remove the hardwire shunt.</p> <ul style="list-style-type: none"> • The island indicator is now green. • Temporarily install the hardware shunt across the island transmitter connections. Use the Track Detail View (see Figure 7) and ensure the EZ value is less than or equal to 5. and the Island Z value is less than 40. If the Z value is greater than 40 repeat Steps 2, 3 and 4. If the Z value remains above 40, REMOVE THE TRACK MODULE FROM SERVICE.

	Track 2	Track 1	Track 2
1	GCP ✓ Calibrated		EZ: 5 EX: 99
2	Approach ✓ Calibrated		Computed Distance: 3022
3	Linearization ✓ Calibrated		Linearization Steps: 100
4	Island ✓ Calibrated		Island:  Z Level: 35

Figure 7 Track View EZ Level and Island Z Level

Table 13: Island Shunt Distance

Island Frequency (kHz)	Shunt Distance (Feet/Meters)			
	0.12 ohm Sensitivity	0.3 ohm Sensitivity	0.4 ohm Sensitivity	0.5 ohm Sensitivity
2.14	20/6.1	50/15.2	67/20.4	84/25.6
2.63	17/5.2	43/13.1	58/17.7	72/22
3.24	13/4	33/10.1	44/13.4	55/16.8
4.0	10.5/3.2	27/8.2	36/11	45/13.7
4.9	9.0/2.7	23/7.0	31/9.5	39/11.9
5.9	7.5/2.3	19/5.8	26/7.9	32/9.8
7.1	6.5/2	17/5.2	23/7.0	29/8.8
8.3	6.0/1.8	15/4.6	20/6.1	25/7.6
10.0	5.0/1.5	13/4	18/5.5	22/6.7
11.5	4.5/1.4	12/3.7	16/5	20/6.1
13.2	4.0/1.2	10/3.2	14/4.3	17/5.2
15.2	3.5/1.1	9/2.7	12/3.7	15/4.6
17.5	3.0/0.9	8/2.4	11/3.4	14/4.3
20.2	3.0/0.9	8/2.4	11/3.4	14/4.3

WARNING

When using SSCC IIIi MEF xng02_00 or earlier, gates will begin to lower immediately (without gate delay time) when the transfer switch is used to swap between healthy units. Use caution when transferring control to avoid gates hitting vehicles or pedestrians.

NOTE

Under normal conditions in the AUTO Transfer mode, gate delay time will run when the gates initially operate. If the trouble continues, the gates will already be lowered when the Transfer Module later swaps units.

Repeat all GCP, Approach, Linearization, and Island calibration steps for each MAIN side module installed.

Table 14: Standby Modules Calibration

Step 1	On Transfer module A80406 (A80468), set the transfer switch to STBY .
Step 2	If a 60 or 100 Hz Cab Signal is in use, turn it off at this time.
Step 3	From the System View menu, select the track to calibrate, i.e., 1 – 6 by entering that number on the keypad. The menu shows only enabled tracks.
Step 4	From the Track Options menu, select 3) Calibration . The Track “N” Window appears, depicting the Calibration status of: 1) GCP, along with EZ and EX values 2) Approach, along with Computed Distance 3) Linearization, along with Linearization Steps 4) Island, along with Island Status and Z Level If Calib Required appears on any of the above lines, calibration is required.

Table 14: Standby Modules Calibration

<p>Step 5</p>	<p>Select 1) GCP. The Track “N” GCP Calibration Window opens, listing 1) Start Calibration and 2) Add Comment. Select 1) Start Calibration. The Display module depicts Initiating, then In Progress messages during the calibration. If calibration is successful:</p> <ul style="list-style-type: none"> • Passed, please wait appears in the window. • EZ should be 98 to 102 and the 1) GCP line has a green check next to Calibrated. <p>If calibration is not successful, the Display module shows a Failed message.</p>
<p>Step 6</p>	<p>To record the reason for the recalibration in the Maintenance log, select 3) Calibration.</p> <ul style="list-style-type: none"> • The Track “N” Window appears. • Select 2) Add Comment. • On the Enter Text tile, type any notes concerning the reason and select Enter.
<p>Step 7</p>	<p>If the cab signal was turned off in Step 2, turn it on.</p>
<p>Step 8</p>	<p>Once GCP Calibration is completed, bypass the approach calibration by first selecting 2) Approach. After the Track “N” Approach Calibration Window opens, select 3) Bypass. Do not select 1) Start Calibration.</p>
<p>Step 9</p>	<p>Bypass the linearization calibration by first 2) Approach. After the Track “N” Linearization Calibration Window opens, select 3) Bypass. Do not select 1) Start Calibration.</p>
<p>Step 10</p>	<p>Record the EZ and EX values for the track (before installing hardwire shunt) in the Step 1 Step 2 column (Calibrated Values) on Figure 5 form found on page 24. Then, temporarily place a hardwire shunt across the termination shunt. For bidirectional installations, use the termination shunt furthest from the crossing.</p>
<p>Step 11</p>	<p>Record the EZ and EX values for the track in the First Approach, Step 2 columns of Figure 5.</p>
<p>Step 12</p>	<p>Select 2) Approach. The Track “N” Approach Calibration Window opens, listing 1) Start Calibration, 2) Edit and 3) Add Comment.</p>
<p>Step 13</p>	<p>Select 1) Start Calibration. The Display module reports Initiating, then In Progress during the calibration. If calibration is successful:</p> <ul style="list-style-type: none"> • Passed, please wait appears in the window, followed by Calibrated. • The Computed Distance value appears and the 2) Approach line has a green check next to Calibrated. <p>If calibration is not successful, the Display module shows a Failed message.</p>
<p>Step 14</p>	<p>Record the computed approach distance in feet or meters in the Second Approach, Step 17 column on Figure 6, also found on page 25.</p>

Table 14: Standby Modules Calibration

Step 15	Accurately (within 1%) locate the midpoint of this approach and move the hardwire shunt to that point on the rails.
Step 16	Select 3) Linearization . The Track “N” Linearization Calibration Window opens, listing 1) Start Calibration, 2) Edit, 3) Bypass and 4) Add Comment .
Step 17	Select 1) Start Calibration . The Display module reports Initiating , then In Progress during the calibration. If calibration is successful: <ul style="list-style-type: none"> • Passed, please wait appears in the window, followed by Calibrated. • The Linearization Steps value appears and the 3) Linearization line has a green check next to Calibrated. If calibration is not successful, the Display module shows a Failed message.
Step 18	Record the linearization (Linearization Steps) value (between 68 and 132) for the track in the Second Approach, Step 21 column (Linearization Steps) on Figure 6. Verify that the computed approach distance in feet or meters (Computed Distance , Step 17) and the linearization steps (Linearization Steps , Step 21) values recorded are the same as the values displayed on the Calibration Select window.
Step 19	Remove the hardwire shunt from the track.
Step 20	If the Linearization Steps value for the second approach (Figure 6, Step 21) is greater than or the same as the Linearization Steps value recorded for the first approach (Figure 5, Step 9), go to Step 31. If the Linearization Steps value for the second approach (Figure 6, Step 21) is less than the value recorded for the first approach (Figure 5, Step 9), go to Step 24.
Step 21	Select 3) Linearization . The Track “N” Linearization Calibration Window opens, listing 1) Start Calibration, 2) Edit , and 3) Add Comment .
Step 22	Select 2) Edit . The New Value screen opens.
Step 23	If the approach is unidirectional or simulated bidirectional, go to Step 31. If the track is bidirectional and the measured distance to the other termination shunt is within 10 % of the first approach distance, go to Step 13. If the distance is clearly shorter, go to Step 31.
Step 24	Temporarily place a hardwire shunt across the termination shunt of the other approach.
Step 25	Record the EZ and EX values for the track in the Second Approach, Step 14 columns of Figure 6.
Step 26	Select 2) Approach . The Track “N” Approach Calibration Window opens, listing 1) Start Calibration, 2) Edit and 3) Add Comment .

Table 14: Standby Modules Calibration

Step 27	<p>Select 1) Start Calibration. The Display module reports Initiating, then In Progress during the calibration.</p> <p>If calibration is successful:</p> <ul style="list-style-type: none"> • Passed, please wait appears in the window, followed by Calibrated. • The Computed Distance value appears and the 2) Approach line has a green check next to Calibrated. <p>If calibration is not successful, the Display module shows a Failed message.</p>
Step 28	<p>If the approach is unidirectional or simulated bidirectional, go to Step 31. If the track is bidirectional and the measured distance to the other termination shunt is within 10 % of the first approach distance, go to Step 13. If the distance is clearly shorter, go to Step 31.</p>
Step 29	<p>Temporarily place a hardwire shunt across the termination shunt of the other approach.</p>
Step 30	<p>Record the EZ and EX values for the track in the Second Approach, Step 14 columns of Figure 6.</p>
Step 31	<p>Select 2) Approach. The Track “N” Approach Calibration Window opens, listing 1) Start Calibration, 2) Edit and 3) Add Comment.</p>
Step 32	<p>Select 1) Start Calibration. The Display module reports Initiating, then In Progress during the calibration.</p> <p>If calibration is successful:</p> <ul style="list-style-type: none"> • Passed, please wait appears in the window, followed by Calibrated. • The Computed Distance value appears and the 2) Approach line has a green check next to Calibrated. <p>If calibration is not successful, the Display module shows a Failed message.</p>
Step 33	<p>Record the computed approach distance in feet or meters in the Second Approach, Step 17 column of Figure 6.</p>
Step 34	<p>Accurately (within 1%) locate the midpoint of this approach and move the hardwire shunt to that point on the rails.</p>
Step 35	<p>Select 3) Linearization. The Track “N” Linearization Calibration Window opens, listing 1) Start Calibration, 2) Edit, 3) Bypass and 4) Add Comment</p>
Step 36	<p>Select 1) Start Calibration. The Display module reports Initiating, then In Progress during the calibration.</p> <p>If calibration is successful:</p> <ul style="list-style-type: none"> • Passed, please wait appears in the window, followed by Calibrated. • The Linearization Steps value appears and the 2) Approach line has a green check next to Calibrated. <p>If calibration is not successful, the Display module shows a Failed message.</p>

Table 14: Standby Modules Calibration

<p>Step 37</p>	<p>Record the linearization (Linearization Steps) value (between 68 and 132) for the track in the Second Approach, Step 21 column (Linearization Steps) on Figure 6. Verify that the computed approach distance in feet or meters (Computed Distance, Step 17) and the linearization steps (Linearization Steps, Step 21) values recorded are the same as the values displayed on the Calibration Select window.</p>
<p>Step 38</p>	<p>Remove the hardwire shunt from the track.</p>
<p>Step 39</p>	<p>If the Linearization Steps value for the second approach (Figure 6, Step 21) is greater than or the same as the Linearization Steps value recorded for the first approach (Figure 5, Step 9), go to Step 31. If the Linearization Steps value for the second approach (Figure 6, Step 21) is less than the value recorded for the first approach (Figure 5, Step 9), go to Step 24.</p>
<p>Step 40</p>	<p>Select 3) Linearization. The Track “N” Linearization Calibration Window opens, listing 1) Start Calibration, 2) Edit, and 3) Add Comment</p>
<p>Step 41</p>	<p>Select 2) Edit. The New Value window opens</p>
<p>Step 42</p>	<p>Enter the Linearization Steps value recorded on the Figure 5 for the first approach (Step 9) into the New Value field using the keypad numbers and select Enter.</p> <ul style="list-style-type: none"> • The new value appears on 3) Linearization.
<p>Step 43</p>	<p>Select 2) Approach. The Track “N” Approach Calibration Window opens, listing 1) Start Calibration, 2) Edit and 3) Add Comment.</p>
<p>Step 44</p>	<p>Select 2) Edit. The New Value window opens.</p>
<p>Step 45</p>	<p>Enter the computed approach distance value recorded for the first approach (Figure 5, Step 5) into the New Value field using the keypad numbers and select Enter.</p> <ul style="list-style-type: none"> • The entered value appears on 2) Approach.
<p>Step 46</p>	<p>Verify that the computed approach distance (Computed Distance, Step 5) and the linearization steps (Linearization Steps, Step 9) values recorded on Figure 5 for the first approach are the same as those displayed on the Track “N” window.</p>

Table 14: Standby Modules Calibration

Step 47	Transfer the information written in Figure 5 and Figure 6 ABOVE onto Figure 1 and Figure 2 of the Model 5000 GCP Application History Card, SIG-00-04-21 and Figure 1 and Figure 2 of the Model 5000 GCP System Cutover Test Procedure and Check Off Sheet, both of which are found at the back of the Model 5000 GCP Family Application Guidelines Manual, SIG-00-08-10. If the initial settings of the GCP were changed or equipment changes were made such that require recalibration of the GCP, Approach, and Linearization, place the updated Computed Distance and Linearization Steps data in Figure 3 and Figure 4 of the History Card also found at the end of the Model 5000 Application Guidelines.
Step 48	To record the reason for the Calibration and store it in the Maintenance log, select 3) Linearization and then 3) Add Comment . <ul style="list-style-type: none">• Type any notes about the calibration and select Enter to save the entry.
Step 49	Repeat Steps 1 through 48 for each standby-side Track Module installed.

ADJUSTING LAMP VOLTAGES FOR SSCC IIIi

(When a “True RMS AC + DC” meter is not available)

General

⚠ WARNING

To prevent an over-voltage condition at the lamps, use a voltmeter with a “True RMS AC + DC” scale and make all measurements using that scale.

To accurately read the crossing lamp voltages, a “True RMS AC + DC” multimeter (e.g., Agilent U1252A digital multimeter or equivalent) must be used. A conventional multimeter may be used, but the voltage reading will be lower than “True RMS AC + DC” values. The variance is not a set percentage and depends upon battery voltage. A conversion table is provided in the table below.

Table 15: Multimeter Reading Variance From Actual Incandescent Lamp Voltage

Battery Voltage	Regulated Lamp Drive Voltage Range	Measurement Below Actual Drive Voltage	
		Using Digital Multimeter (Not a True RMS AC + DC)	Using Analog Multimeter (TS111)
13.3	9.0 to 12.0	1.3 volts	0.6 volt
	>12.0	0.91 volt	0.42 volt
14.7	9.0 to 12.0	2.2 volts	1.1 volts
	>12.0	1.54 volts	0.77 volt
15.8	9.0 to 12.0	2.6 volts	2.0 volts
	>12.0	1.82 volts	1.4 volts

NOTE

The variance table applies to incandescent lamps and only LED lamps that present a resistive load to the crossing controller, i.e., SSCC IIIi, SSCC A, SSCC III Plus, or SSCC IV. For other kinds of LED lamps, it is recommended that the voltage measured by a meter which is set to “True RMS AC + DC” be considered as correct.

Meter Reading Conversion Examples

Following are two examples of how to measure the lamp voltages using a conventional meter. In both examples:

- Battery bank voltage is 14.7 volts
- Multimeters are set to read DC
- Lamp Voltage Measurement Example 1

When setting crossing lamp voltages to 9.5 volts, the conventional meter reading is determined by subtracting the meter variance given in Table 15 from the desired lamp voltage.

When using a digital multimeter (Not True RMS AC + DC):

- Desired lamp voltage = 9.5
- Meter variance for 14.7 volt battery = -2.2
- Meter reading = **7.3**

When using an analog multimeter (e.g. TS111):

- Desired lamp voltage = 9.5
- Meter variance for 14.7 volt battery = -1.1
- Meter reading = **8.4**

Lamp Voltage Measurement Example 2

In this example, it is desired to check that lamp voltage is greater than 8.5 volts and the battery voltage is 13.3 volts.

When verifying that the lamp voltages are greater than 8.5 VDC, the conventional meter reading is determined by subtracting the meter variance given in Table 15 from the minimum lamp voltage threshold.

When using a digital multimeter (Not True RMS AC + DC):

- Minimum lamp voltage threshold = 8.5
- Meter variance for 13.3 volt battery = -1.3
- Minimum meter reading = **7.2**

When using an analog multimeter (e.g. TS111):

- Minimum lamp voltage threshold = 8.5
- Meter variance for 13.3 volt battery = -0.6
- Minimum meter reading = **7.9**

SSCC IIIi LAMP VOLTAGE ADJUSTMENT

⚠ WARNING

To be accurate, lamp voltages must be measured at the lamp. The voltage on the Display module is the voltage at the SSCC connector. Inaccurate measurements may result in dim lamps or early lamp failure.

NOTE

Before performing Lamp Voltage Adjustment procedure, the crossing controllers must be inactive; i.e., gates up, lights off and bell off. If a train approaches during lamp adjustment, the crossing controllers will activate and the lamps will flash. Restart Lamp Voltage Adjustment Procedure following completion of train move.

The regulated output is a pulse-width modulated output that produces a square wave. A “True RMS AC + DC” meter is required to accurately measure the voltage See Table 15 when using a conventional meter.

If SSCC IIIi modules are included in the system, proceed to SSCC IIIi Lamp Voltage Adjustment and SSCC Lamp Tests. Otherwise, proceed to Operational Checks. Regardless of the actual location of the SSCC IIIi board on the physical case of the GCP, the tabs on the Lamp Setup Window depicts the two choices as Slot 8 SSCC IIIi & Slot 9 SSCC IIIi.

When “far gate” lamps and “near gate” lamps are driven from the same output, first adjust the lamp voltage on the far gate. Then adjust the lamp voltage on the near gate using adjustment resistors.

On the Lamp Setup screen dV indicates tenths of a volt (decivolt). 100 dV is equal to 10.0 volts.

Table 16: Crossing Controller Lamp Voltage Adjustments

Note	<p>From the System View menu, look at the bottom line on the screen. This is the SSCC line. Select the number that is to the left of SSCC (System View > SSCC > Lamp Adjust).</p> <ul style="list-style-type: none">• The SSCC Menu appears <div data-bbox="669 1598 1053 1900" data-label="Image"><p>The image shows a screenshot of a menu titled "SSCC". The menu items are listed with numbers to their left: 1 Lamp Adjust, 2 SSCC Test, 3 Remote Setup, 4 SSCC 1 Diags, and 5 SSCC 2 Diags. The menu is displayed on a dark background with a light border.</p></div> <p>Figure 8 SSCC Menu</p>
-------------	--

Table 16: Crossing Controller Lamp Voltage Adjustments

Step 1	Select 1) Lamp Adjust <ul style="list-style-type: none"> The SSCC/SL8 window appears
Step 2	Select the Lamp 1 Voltage value by pressing Enter on the Display module keypad. <ul style="list-style-type: none"> The illustration of the gate appears with a white background and depicts Lamp 1 as illuminated. Lamp 1: reports On The Set Voltage tile opens.
Step 3	Set the Lamp 1 Voltage field to the output voltage required to set the correct voltage at the lamps. <ul style="list-style-type: none"> Select the voltage by either: <ul style="list-style-type: none"> Scrolling to the desired voltage reading in 1 dV (0.1 V) steps by using the up or down arrows on the keypad or Enter the numeric value using the keypad. Measure voltage at the actual lamps.
Step 4	When the meter displays the correct voltage, select the Enter button. <ul style="list-style-type: none"> The new voltage value is saved. Lamp 1: reports Off Corresponding lamp output is turned off. The Lamp 2 Voltage value is highlighted
Step 5	Select the Enter . The Set Voltage tile opens. <ul style="list-style-type: none"> The illustration of the gate continues to appear with a white background and now depicts Lamp 2 as lit. Lamp 2: reports On Corresponding lamp output is turned on.
Step 6	Set the Lamp 2 Voltage field to the output voltage required to set the correct voltage at the lamps. <ul style="list-style-type: none"> Select the voltage by either: <ul style="list-style-type: none"> Scrolling to the desired voltage reading in 1 dV (0.1 V) steps by using the up or down arrows on the keypad or Enter the numeric value using the keypad. Measure voltage at the actual lamps.
Step 7	When your meter reads the correct voltage, select the Enter button <ul style="list-style-type: none"> The Lamp 2 Voltage field deactivates. Lamp2: reports Off The new voltage value is saved. Corresponding lamp output is turned off.
Step 8	Select the SSCC/SL9 by scrolling using the right or left arrows.
Step 9	Repeat Steps 1 through 8 for the second SSCC Illi module.

OPERATIONAL CHECKS

SSCC IIIi TEST MODE

WARNING

The SSCC test mode will not preempt traffic signals. Verify that vehicles are clear of the warning devices before activating the signals.

NOTE

While in Test Mode, if a train approaches (XR input logic de-energizes), the test is cancelled and the crossing activates normally. When the train departs, the system remains in normal operation.

Table 17: Crossing Controller Lamp Test Selection

Step 1	From the System View menu, select the number that appears to the left of the SSCC line at the bottom of the screen (System View > SSCC > SSCC Test). <ul style="list-style-type: none">• The SSCC Menu appears
Step 2	Select 2) SSCC Test <ul style="list-style-type: none">• The SSCC/SL8 window appears

The operation of each Solid State Crossing Controller (SSCC IIIi) can be tested from this window.

Select the Crossing controller using the right or left arrow to scroll to either

- Slot 8 SSCC IIIi
- Slot 9 SSCC IIIi

The SSCC/SL8 Menu appears with the Select Test field highlighted. When the Enter button is selected, the SSCC Test menu opens.

SSCC TEST MENU

The following SSCC tests may be performed:

- 1) Bell: Turn on the bell output
- 2) Lamp 1: Turn on Lamp 1 output
- 3) Lamp 2: Turn on Lamp 2 output
- 4) Flash the Lamps: Test the lamp outputs on both controllers
- 5) Test the crossing: Flash the lights, ring the bell, run the gate delay, and then drop the gate.
- 6) Perform a Timed Test
- 7) Perform a Repeat Test

Types of Tests

Timed Tests: When the Timed Test is started, the GCP performs the following sequence:

1. pauses for the programmed Lamp Test Delay time
2. flashes the lamps for the programmed Lamp Test On time
3. turns the lamps off
4. stops the test.

Repeat Tests: When the Repeat Test is started, the GCP performs the following sequence:

1. pauses for the programmed Lamp Test Delay time
2. flashes the lamps for the programmed Lamp Test On time
3. turns the lamps off for three times the programmed Lamp Test Delay Time
4. flashes the lamps for the programmed Lamp Test On time
5. turns the lamps off
6. stops the test.

Parameters for Timed Tests

Parameters for each SSCC timed test are set in the fields below the Select Test: field.

The Lamp Test On field designates the duration of the Lamp On test.

Select the **Enter** button to the right of the field to open the Lamp Test On (sec) dialog box. This Lamp Test On (sec) dialog box allows the test duration timer to be modified.

- Default value: 15 sec
- Valid entry range: 15 to 60 seconds

The Lamp Test Delay field designates the time between test selection and test start. Select the **Enter** button to the right of the field to open the Lamp Test Delay (sec) dialog box. This Lamp Test Delay (sec) dialog box allows the Lamp Test Delay timer to be modified.

- Default value: 30 sec
- Valid entry range: 30 to 120 seconds

The Lamp Test Cancel field designates the automatic test termination time following test initiation. Select the **Enter** button to the right of the field to open the Lamp Test Cancel (min) dialog box. This the Lamp Test Cancel (min) dialog box allows the Lamp Test Cancel timer to be modified.

- Default value: 5 min
- Valid entry range: 1 to 15 minutes

Test Status Indications

The status of the SSCC IIIi module appears in the gate display field at the bottom of the window during tests.

Four status notations appear during operational tests:

- **Off** indicates that the SSCC IIIi lamp drive outputs are off.
- **Ringing** indicates that the SSCC IIIi module bell output is energized.
- **Flashing** indicates that the SSCC IIIi module lamp outputs are alternately energizing (flashing).
- **Failed** indicates that a bell, lamp, or crossing gate output failure has been detected.

GCP OPERATIONAL TEST MODE

Prior to placing a system in service, tests must be performed to verify proper system operation and I/O wiring. Proceed to next step if a feature is not used.

⚠ WARNING

After initial programming or programming, module, track, or wiring changes, tests must be performed to verify proper operation of the GCP prior to placing a system in service.

⚠ WARNING

If a rapid change occurs in the value of EZ at any time the train is moving within the termination shunts, track discontinuity caused by a high resistance bond or a defective coupler is indicated. Locate and correct the problem immediately.

The railroad procedures governing how to take a track circuit out of service shall be followed. The instructions in this section may be followed only if allowed by the railroad.

To track the EZ, access Table D.2 Using Recorded EZ & EX Files.

Table 18: GCP Operational Tests

Step 1	Check tracks for: <ul style="list-style-type: none">• Open transmit wire• Crossing activates• EZ = 0• Open receive wire• Crossing activates• EZ = 0
Step 2	UAX, DAX Enables & AND Enable input(s), if these features are used: <ul style="list-style-type: none">• Crossing activates when each remote DAX line circuit that controls a UAX, DAX Enable or AND Enable input (controlling the crossing) is de-energized or opened from the far end of the circuit.• Pickup Delay time is correct when input closes.
Step 3	DAX outputs and "Vital Comms" operation using Spread Spectrum Radio or Ethernet link, if these features are used: <ul style="list-style-type: none">• Downstream crossing activates when the appropriate DAX output or Vital Comms message is de-energized• DAX Pickup Delay time is correct

Table 18: GCP Operational Tests

<p>Step 4</p>	<p>Wrap logic, if this feature is used:</p> <ul style="list-style-type: none"> • Wrap logic W is displayed on Main status screen for each corresponding wrapped track (when Wrap inputs are energized as seen on system I/O view). <p>W is removed from corresponding track on Main status screen when:</p> <ul style="list-style-type: none"> • Corresponding track with wrap is shunted or • Corresponding wrap input is de-energized <p>Measure Wrap LOS pick-up delay from the time the wrap input is energized until the W is displayed on corresponding track status screen. Verify the LOS pickup delay time (minimum of 5 seconds).</p>
<p>Step 5</p>	<p>Override logic, if this feature is used. There may be one or up to three Override inputs used depending on Override programming. The Override options are: ALL PREDICTORS Override or DAX A, DAX B and DAX C Override.</p> <p>When corresponding Override input is energized, Override Input Status is Green on System I/O view.</p> <ul style="list-style-type: none"> • Observe that corresponding Override input changes to Red when: • Corresponding switch in GCP approach is reversed or • Corresponding signal field apparatus is changed from energized to de-energized or de-energized to energized depending on field signal logic for Override.
<p>Step 6</p>	<p>Traffic Signal Preemption, if this feature is used:</p> <p>The preempt output de energizes:</p> <ul style="list-style-type: none"> • When the prime de energizes for simultaneous preemption • At the programmed preemption warning time for advance preemption • The warning devices activate when the prime predictor predicts, or after the Advance Preempt Delay timer times out, whichever is sooner. Time should be equal to Adv Preemption timer value or shorter. <p>When used, Advance Preempt IP input open causes Preempt Output to de-energize and activates warning devices after the Advance Preempt Delay Timer times out. (Observe input on I/O view).</p> <p>When used, Preemption Health IP input open activates warning devices immediately (without advance preempt Delay time interval). (Observe input on I/O view).</p> <p>When used, Traffic Signal Health open initiates simultaneous preemption, rather than advance preemption, upon train detection.</p>

Table 18: GCP Operational Tests

<p>Step 7</p>	<p>Island detection: When used, observe the Island symbol on tracks on the Main Status display.</p> <ul style="list-style-type: none"> • Place a 0.06 ohm shunt on island track wires • Island symbol is Gray • Observe island LED on track module as shunt is removed and while Island Pickup Delay is timing <p>Island LED is flashing:</p> <ul style="list-style-type: none"> • After the island pickup delay time expires on module and island LED is steady Red • Island symbol on Main display is Green, and warning devices are deactivated.
<p>Step 8</p>	<p>Out of Service (OOS), if this feature is used: If the Display method is used:</p> <ul style="list-style-type: none"> • Take each track out of service using the Display module. • Verify that the Display module indicates track is OOS <p>Return track to service</p> <ul style="list-style-type: none"> • Display module indicates track is back in service <p>If Display + OOS IP input is used, then for each track:</p> <ul style="list-style-type: none"> • Turn on OOS input for the track (observe input on I/O view). • Take track OOS using the Display module • Display module indicates track is OOS • Turn off OOS input • Display module indicates track is back in service <p>If OOS IP Input is used:</p> <ul style="list-style-type: none"> • Turn on OOS input for the track (observe input on I/O view). • Main Display module indicates track is OOS • Turn off OOS input • Display module indicates track is back in service <p>If 5000 Case OOS IP Input used:</p> <ul style="list-style-type: none"> • Turn on 5000 Case OOS input. (observe input on I/O view). • Main Display indicates all track are OOS • Turn off 5000 Case OOS input • Main Display indicates all tracks are back in service
<p>Step 9</p>	<p>Maintenance Call (MC) Light, if this feature is used:</p> <ul style="list-style-type: none"> • Verify that the light is lit • Verify that the MC extinguishes when one of the following occurs: • Taking a track out of service, or by energizing an out-of-service input. • If “Low Battery Enable” is ON, temporarily raise the “Low Battery Level” to above the battery voltage. • Removing CPU module from the chassis, which will activate the crossing also. <p>Restore the track, low battery level, or CPU module to operation and the MC light should turn on.</p>

Table 18: GCP Operational Tests

Step 10	If Positive Start, Advanced Approach Prediction, and/or Sudden Shunt Detection are used: <ul style="list-style-type: none">• Shunt at the appropriate point• Take the required measurements• Reprogram EZ threshold levels as required
----------------	--

Finishing Step 9 or, if required, Step 10 completes the GCP operational checks / tests. Proceed to SSCC IIIi Operational Tests for SSCC calibration and operational checks / tests.

SSCC IIIi OPERATIONAL TESTS

After the system has been programmed, GCP calibrated and the lamp voltages have been adjusted, tests must be performed to verify the operation of the SSCC prior to placing the system in service. In addition to the operational tests required by the maintaining railroad, the SSCC operation should be further tested and verified as described in the SSCC Operational Tests procedure provided below.

WARNING

After initial programming or programming, module, or wiring changes, tests must be performed to verify proper operation of the SSCC prior to placing the system in service.

NOTE

While in Test Mode, if a train approaches (XR input logic de-energizes,) the test is cancelled and the crossing activates normally. When the train departs, the system remains in normal operation.

If advance preemption is used, the preemption output and warning devices will operate as follows for the indicated method of activation:

- For a train move:
 - Preemption Output de-energizes at the preempt warning time.
 - Activation of the warning devices will be delayed until the Advance Preempt Timer times out, or the Prime Warning time is reached.
- Advance Preempt Input de-energized:
 - Preemption Output de-energizes
 - Activation of the warning devices will be delayed until the Advance Preempt Timer times out.
- AND 1 Enable Input de-energized:
 - Preemption Output de-energizes
 - Activation of the warning devices occurs simultaneously (no advance preempt time).
- "Test the Crossing" Test Mode;
 - Preemption Output de-energizes
 - Activation of the warning devices occurs simultaneously (no advance preempt time).

Table 19: SSCC Operational Tests

Step 1	Verify that the light/gate battery is charged.
Step 2	Verify that all connectors on the SSCC have been properly positioned, seated and secured.
Step 3	Verify that all the electrical connections in the Bell, Lamp, and Gate circuits are properly assembled, tightened and secured.
Step 4	Verify that all flashing lamps light and none are burned out.
Step 5	Verify that all lights have been aligned.
Step 6	Verify that the gates are properly adjusted and operational.
Step 7	Verify that the bells are operational.
Step 8	Verify that all SSCC programming is correct (program and configure menus).
Step 9	Verify that all lamp voltages have been set.
Step 10	Momentarily turn on the flashers from the Test menu and verify that the battery charger is operational and providing current to the lamps and battery.
Step 11	Verify that the gate delay time is correct.
Step 12	Verify that the lights continue to flash while the gates are rising.

After performing SSCC Lamp Mode Tests, GCP Operational Tests, and SSCC Operational Tests, verify proper Train Detection, Warning Times and Crossing Operation.

Table 20: Train Detection, Warning Times and Crossing Operation

Step 1	<p>EZ continuity check on train moves:</p> <ul style="list-style-type: none"> • Crossing devices activate and EZ value decreases smoothly (without rapid change) for an approaching train. • Crossing devices turn off when island recovers after train move and the EZ rises smoothly (without rapid change) as the train recedes. To track EZ, reference section • D.2 – Using Recorded EZ & EX Files
Step 2	For MAIN and STANDBY, check warning times for inbound train moves on each approach including DAX operation.
Step 3	Check for proper gate / flasher / bell operation on all train moves.

SEAR ACCESSORY GROUP

The SEAR accessory comprises those items that report the status of various crossing components or allow a single person to perform various calibration and inspection functions.

Mini Trackage Sensor Package (MTSS)

The MTSS reports the status of the gate (up or down), the gate tip, and the bell. It is installed and programmed as directed in Siemens Mobility, Inc. Mini Trackage Sensor Package User's Guide, SIG-00-03-05-001.

VHF Communicator, A80276

The VHF Communicator is used to allow a single maintainer to calibrate the system, set up lamps, and/or test the crossing gate functions. It is installed and programmed as directed in Siemens Mobility, Inc. VHF Communicator User's Guide, SIG-00-03-05-002.

Ground Fault Tester 2 (GFT-2), A81010-0X

The GFT-2 provides battery status reports. It is installed and programmed as directed in Siemens Mobility, Inc. Ground Fault Tester User's Guide, SIG-00-15-06.

Intelligent Light Out Detector (iLOD), A80271

The iLOD provides information on the current in the lamp circuit as well as the flash rate of the lamps. It is installed and programmed as directed in Siemens Mobility, Inc. iLOD User's Manual, SIG-00-03-05-005.

INSTALLATION OF iLOD MODULE

To install the iLOD using the GCP 5000 Display module:

1. use the following path: **Program View > 3) SEAR Programming > 9) SEAR Setup 3) Module Install.**

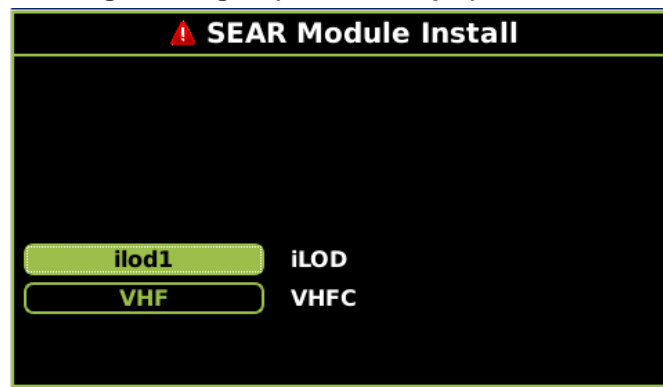

Figure 9 Installing an iLOD

2. Select the iLOD module to install. The Display module will then indicate Module install is in Progress...Waiting for service msg...Please Wait...Press Back Key to Cancel Install Request.
3. The Display module will indicate once the installation process is complete.

To install the iLOD using the GCP 5000 WebUI:

1. Locate the IP address of the GCP 5000 unit via the Display module (**Program View > 4) Display Programming > 2) Ethernet Ports > 1) Laptop > Status**) Type into a compatible web browser with https:// in front of it. The web browser will warn that the connection is not private. Select Advanced then Proceed to https://192.168.255.81.
2. Log into the WebUI using the appropriate User Name and Password.

3. Access the **Configuration** icon from the top menu bar, then select **SEAR Programming > Echelon Modules**.

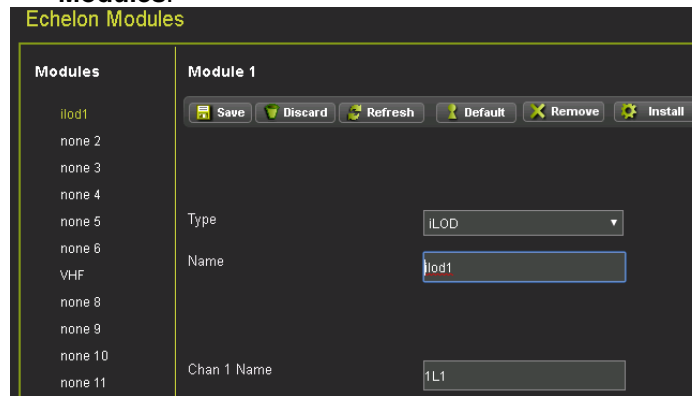

Figure 10 Installing iLOD via WebUI

4. Select the Type of module via the drop down, then select **Install**.
5. The WebUI will indicate **Waiting for service msg...** while processing, then will indicate when the process is successful.

LAMP CALIBRATION OF iLOD

The lamp calibration process for an iLOD sets the internal threshold levels used by the iLOD software to detect flashing lamp current. These levels are site specific. It also is used by the application program to determine the number of lamps and the current draw that is present for a properly operating crossing. This process is not the same as factory calibration. Factory calibration is performed on the iLOD units before shipment.

NOTE

All key presses in the following procedure are done from the front panel keypad on the GCP 5000 Display module.

1. To access Lamp Calibration, select: **Program View > 3) SEAR Programming > 9) SEAR Setup 2) Lamp Calibration** on the Display module, OR access the WebUI (see preceding iLOD installation procedure) and select **System View > SEAR > Lamp Calibration**.
2. If there is an application program loaded into the SEAR, enter the number of flashing lamps for each iLOD sensor when requested.

NOTE

If the site has Gate Tip Sensors installed, when asked to flash the lamps, make sure the gates are level before pressing **Enter**. The current reading is allowed to “settle” for 15 seconds.

3. Depending on the configuration of the crossing, it may be necessary to repeat this process with AC power to the crossing turned off. At some installations, the process may be repeated more times depending on configuration (split tracks, etc.).

NOTE

A pair of flashing lamps count as one lamp and each tip light counts as one flashing lamp. Count only the lamps that go through that sensor. The lamp count may be on the site plans.

4. When the process is complete, the Display module will return to SEAR Program Menu.

SEAR Ili SETUP

Review the program in the Model 5000 GCP by using the left or right arrows on the Display module and scrolling to the Program View screen, then scrolling down to or selecting **3) SEAR Programming** menu.

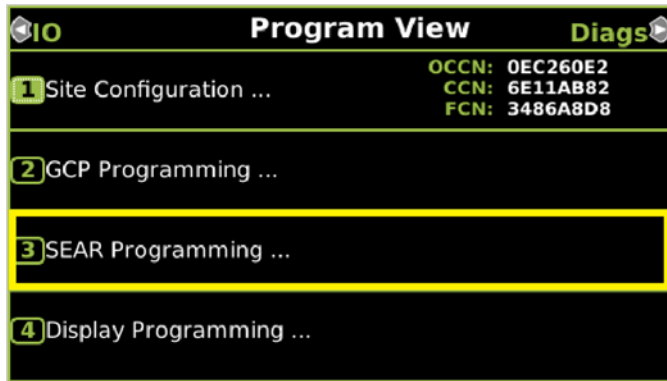

Figure 11 Program View

NOTE

The Control Descriptor Language (CDL) used to customize the SEAR's operation, settings, and behavior can differ between railroads.

Refer to the specific SEAR Ili Configuration Summary document for details of application CDL program, LEDs, and Alarms. The ATCS address must be entered prior to the SEAR Ili communicating with the CPU Module.

Prior to beginning the SEAR Ili setup procedure, have circuit plans showing the SEAR Ili setup page available for reference.

Site Setup must be run in its entirety. Setup may be accomplished either using the Display module or the WebUI.

The first nine (9) parameters, appearing on the first page of the SEAR Program Menu, are as follows:

- 0) Menu
- 1) Application(CDL)
- 2) Digital Inputs
- 3) Analog Inputs
- 4) Non-Vital Outputs
- 5) Echelon Modules
- 6) Communication
- 7) Serial Ports
- 8) Set to Defaults
- 9) SEAR Setup

Select **1) Application(CDL) > 1) CDL Setup**. Step through the first group of parameters of SEAR Programming by answering each question as indicated by the SEAR Program Menu setup page in the crossing's circuit plans.

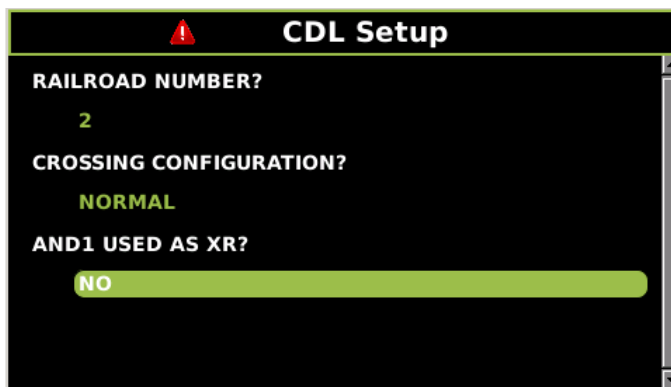

Figure 12 CDL Setup Screen

SEAR Ili OPERATION

Now that site setup is complete, peripheral devices, as well as items onboard the SEAR Ili will be checked for proper operation. This ensures that the SEAR Ili is receiving all the information it needs for proper alarming and execution of the SEAR Application Program. All items in this section can be done through similar menus on the Model 5000 GCP WebUI.

All peripheral equipment on the Echelon[®] network will need to be checked for good communication with the SEAR Ili. All of those modules can be checked in one screen by scrolling to **IO & Logic View > 4) SEAR**. This opens the SEAR I/O submenus. The submenus are displayed in the following order when the right arrow is pressed:

- Digital Inputs 1..16 (includes iLOD and VHF)
- Digital Inputs 17..32
- Digital Inputs 33..48
- Digital Inputs 49..63
- Analog Input
- Digital Outputs
- LEDs
- MTSS (If installed, otherwise message "No MTSS Data Found in Database!!" appears)
- GFT (If installed, otherwise message "No GFT Data Found in Database" appears)
- SEAR Module Status

The type of module will be shown on the left and the communication status will be on the right. The status of each module should be "GOOD."

Verify Operation Of MTSS/Gate Tip/Bell Sensor:

- The MTSS can be monitored via the following path: **IO & Logic View > 4) SEAR** then scroll to the left twice (or right seven times) as per the bulleted menu list in the preceding section. As with the GFT, if the input shows STUCK LOW, then the data wire between the MTSS and SEAR Ili is open and will need to be repaired.

If the data connection is good, the following would be displayed for TSS1:

- TSS1: U=1 D=0 T=0 A=0 P=0
 - U=Gate Up
 - D=Gate Down
 - T=Gate Tip Sensor
 - A=Bell Audio
 - P=Bell Power

NOTE

These items can be either 1 or 0. In the example, U=1 so the gate up contact is energized. The other items are all de-energized. Dropping the gates to horizontal will activate the tip sensors and de-energize the gate up contact, changing the MTSS data to U=0 and T=1. Activating the bell will check the bell sensor; A & P should both equal 1 when the bell is on.

Verify Operation of Ground Fault Testers (GFTs):

- All LEDs on the GFT units should be on steady. If the BAT 1 Fault or BAT 2 Fault LEDs are slow-flashing then they have detected a ground condition.
- The GFT can be monitored at **IO & Logic View > 4) SEAR** and then press the left arrow keys once to display the GFT input. If the input shows STUCK LOW, that indicates the data wire between the GFT and SEAR Ili is open and will need to be repaired.

If the data connection is good, the following would be displayed for GFT1

- GFT1: HL=G MD=N B1=0 B2=0.
- HL=G indicates that the GFT health is good.
- MD=N indicates that test mode=no.
- B1 & B2 = 0 shows that there are no ground faults on BAT 1 or BAT 2.

A ground can be simulated on those inputs by running a wire from the ground input of the GFT to each BAT input, one at a time. The state of each BAT input will change to '1' if a ground is present.

The SEAR Ili relays must function properly in order to run automated inspection tests. These outputs are most easily tested using the SEAR menu on the Model 5000 GCP Display module.

- Verify SEAR Ili relays:
 - Go to MENU>DIAG/MONITOR>RELAYS>GndFitTest and press ENTER.
 - Then press '1' to energize the relay output. Both Ground Fault Testers' BAT FAULT LEDs should be flashing.
 - Now press '0' to de-energize the relay. The LEDs should go on steady.
 - Press EXIT and then ENTER to get back into the RELAYS menu.
 - Select AC Control. Press '1' to energize the relay output. AC power to the chargers should go off, or Press '0' to de-energize the relay and be sure that AC power to the chargers is restored.

Press "exit" until the date/time main screen is visible.

Verify Operation Of iLOD:

- Once good communication is verified, further checks of the iLOD can verify that it is seeing normal amperage/flash rates.
- To view these values in real time, select **IO & Logic View > 4) SEAR** and then scroll to choose the iLOD unit to view. It is under SEAR I/O > Digital Inputs 1..16
 - In that screen both sensors are shown, the first iLOD unit will show EB1, EN1. When the lamps are flashed, both sensors should display that lamps are on, the amperage reading, and the flash rate in flashes per minute.
 - These values are shown in real time; they should be steady and not fluctuate. If the value fluctuates, the lighting circuit will need to be checked for intermittent operation.

NOTE

iLODs must have been installed in the network and field-calibrated before verifying operation.

SEAR Ili Communication

Testing communications to the office can be accomplished using a menu function to generate a test alarm and by creating events that generate alarms. Before testing the SEAR Ili by sending alarms to the office, the unit must be configured for communications in the Site Setup. Once a SEAR Ili is configured through Site Setup and communication is established, the location will register itself with the WAMS office.

Test Communications with SEAR option on the Display module menu.

- Access the WAMS Test Message via **Diags & Reports > 2) SEAR > 3) WAMS Test Message**.
 - Once you select WAMS Test Message, it will automatically start the process.
 - Under **Status** it will display the message "In Progress" until the process is complete, either with a successful test, or when the system times out.
 - Enter ATCS address of the other crossing.
- To send a test packet to the WAMS office:
 - Press 5
 - Enter railroad specific office address.
 - Refer to circuit plans for office address.

Typically, the office ATCS address is 2.RRR.00.0000, where RRR is the ATCS number assigned to the railroad.

SEAR Ili Alarms

Alarm Generation is the final step in checking out the SEAR Ili/WAMS interface. The following procedure tests the wiring of the various components in the SEAR/ WAMS sub-system.

Ground Fault Alarm

- A ground fault can be simulated on those inputs by running a wire from the ground input of the GFT to each BAT input, one at a time.
- Each Battery's LED will flash when ground fault is detected and a "Ground Fault Detected on xxx" alarm will be generated where xxx represents the Battery name.

Ground Fault Clear

- Removing the wire that simulates the ground will generate a Ground Fault Cleared message.
- Analyzer Failure Alarm
- Remove the connector that powers the GFT or that MTSS unit inside the gate mechanism. Doing so on either unit will cause an "Analyzer Failure" alarm.

Analyzer Normal

- Restoring the connector will generate an Analyzer Normal message.

⚠ WARNING

When using SSCC IIIi MEF XNG02_00 or earlier, gates will begin to lower immediately (without gate delay time) when the transfer switch is used to swap between healthy units. Use caution when transferring control to avoid gates hitting vehicles or pedestrians.

GCP Transferred Alarm

- Force the GCP to switch to Standby via the transfer switch on the Transfer Module.
- This will create a GCP Transferred Alarm.
- Forcing it to switch back will cause another GCP Transferred message.

⚠ WARNING

Take alternate means to warn vehicular traffic, pedestrians and employees. Removal of a SSCC IIIi will cause the gates to descend immediately (without gate delay); however, the lights will not activate.

Crossing Controller Failure Alarm

- Temporarily remove a SSCC IIIi to generate Crossing Controller Failure alarm
- Restore SSCC IIIi for a Crossing Controller Normal message.

False Detection Alarm

- Activate the crossing using test switch (or other method shown on plans) allowing the gates to drop and then cancel activation.
- After 30 minutes a False Detection alarm will be generated.
- If a normal train move occurs prior to the 30 minutes, a Pre-Ring alarm will be generated.

AC Power Off For 20 Minutes Alarm

- Turn off AC power for at least 20 minutes and this alarm will be generated.
- AC Power Back On
- Restore power and wait at least 1 minute.

This completes the SEAR IIIi setup. Proceed to Maintenance Call (MC) light.

TROUBLESHOOTING

The GCP Display module is the main diagnostic tool available to maintenance personnel.

The EZ and EX are shown for each track. A track status area is displayed for each track module in the system (up to six). The approximate speed of a train approaching the crossing is shown as a positive (+) number. The approximate speed of a train moving away from the crossing is shown as negative (-) number.

NOTE

If the Display module is replaced, the logs remain on the chassis via the USB ECD, and any logs stored on the chassis will be shown when called on the new Display module.

Whenever any files are being saved using the Display module, they may be saved either to a computer or to a USB Device.

SYSTEM STATUS INDICATORS AND LOGS

Detail View Track Status Window Color Scheme

From the **System View** screen, select the number of a Track, or the SSCC(s) to review. When the **Track “N” Options** window opens, select **1) Detail View**. The **Module Details** window opens.

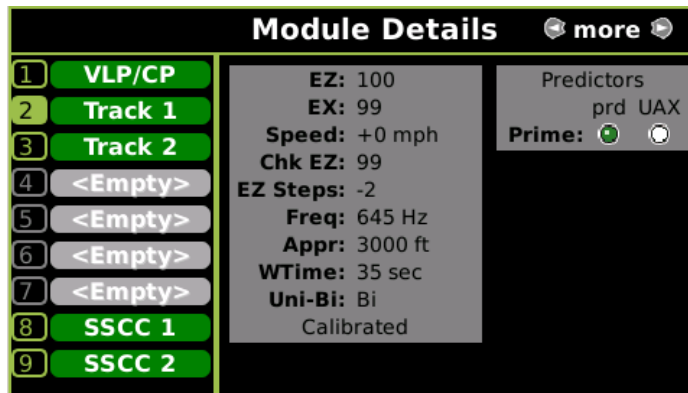

Figure 13 Module Details

The **Module Details** window has two sections. The left section utilizes the following colors:

- Green: The module is currently active and healthy
- Red: The module is currently active and unhealthy
- Grey: The module/slot is inactive and is depicted by <Empty>
- Light Blue: The module is currently Out Of Service (OOS)

The right section displays various information, with the type of information displayed depending upon the type of module depicted:

- VLP/CP Module
- Track Module
- SSCC Module(s)

Selecting the VLP/CP Module line provides:

- Battery Voltage
- Internal Voltage
- Internal Temperature

Selecting the Track Module line provides information on four screens:

- The default screen depicts:
 - Track Status details to include status colors
 - Gray: The Track Module is healthy, and no train is in the approach
 - White: The Track Module is healthy, and a Train is in the approach
 - Red: The Track Module is unhealthy
 - Flashing light blue: The GCP or the GCP/Island is out of service.
 - Predictor Status
- Selecting the right arrow once depicts:
 - Island Status
 - I/O Status
- Selecting the right arrow twice depicts:
- GCP Frequency
 - Approach Distance
 - Prime Warning Time
 - Uni/Bi/Sim-Bidirnl
 - Computed Distance
 - Linearization Steps
 - GCP Transmit Level
 - Island Distance
 - Compensation Level
 - Warn Time-Ballast Comp
- Selecting the right arrow three times depicts the TCN, Date, Time
- Selecting the right arrow four time depicts EZ/EX Limits Status

Track Function Status

The status of optional track functions is displayed at the end of each row depicting active tracks.

- Wrap Circuit Status
 - “W” indicates Wrap input energized.
 - “W” is displayed only when Wrap input is energized and when “Track # Wrap Used” is set to YES.
- Enhanced Detection
 - “ed” indicates enhanced detection has been activated for the current train movement.
 - “ed” is only displayed when “Enhanced Detection Used” is set to YES and inbound poor shunting is detected.
- Motion Sensor Restart
 - “m” indicates that the predictor switched to a motion sensor due to motion sensor control input being low or MS restart timer is running.

ISL and SSCC and System Status Indications

ISL:

- Gray symbol = island occupied
- Green symbol = island unoccupied or, if used, Wrap input energized regardless of occupancy state.
- No symbol = not used

AND:

- Status Bar indicates which AND functions are programmed as shown by a colored block depicting either XR or a number.
- Gray block = the AND function is de-energized and not Wrapped (if used).
- Green block = the AND function is energized and not Wrapped (if used).
- Yellow block = the AND function is Wrapped regardless of state of AND function logic.
- Flashing light blue background = the AND functions are out of service.

SSCC:

- Status bar indicates which SSCC Illi are used as shown by circled number.
 - Green block = not activated (lamps not flashing)
 - Grey circle = signals are activated (lamps flashing)
 - Red circle = signals are activated (lamps flashing)
 - Number not visible = not used

System:

- No Red DIAG triangle on top row = all tracks are calibrated
 - track conditions are within normal operating parameters
 - system is fully functional
- Red DIAG triangle on top row = unhealthy system or track condition exists.
 - displays system status
 - status window for affected track also displays red

Additional information is obtained by selecting the item number, which opens the Track "N" Options window and selecting **1) Detail View**. The Module Details window opens.

The **2) Diagnostics, 3) Track Setup, 4) Calibration, 5) Remote Setup**, and **6) Out Of Service** menus are also available when the track is selected in the main status window.

Displayed under the **Track # Options > 1) Detail View**, the train speeds displayed are relative and may be affected by track parameters that include:

- Insulated joint proximity
- Insulated joint couplers
- Overlapping termination shunts
- Lumped ballast loads

The speed values are only intended to assist maintenance personnel in:

- Identifying slow versus fast train movements
- Distinguishing between accelerating, decelerating, and relatively constant speed train movements

The primary function of the recording is to document warning time.

NOTE

The recorder speed information is intended solely as a maintenance tool.

Speed values are secondary and may not be consistent with recordings made by devices specifically designed to record train speed. Due to electrical variations in the approach, the GCP speed will very rarely ever exactly match the speed shown by the locomotive speed recorder.

History Logs

NOTE

If the Display module is replaced, the logs remain on the chassis, and any logs stored on the chassis will be shown on the new Display module when called.

There are four types of history logs that may be accessed as shown below:

- Train History Log
- Maintenance Log
- Status Log
- Summary Log

Train History Log

There is a separate log for Main and Standby, with all logs stored on the Display module.

Each log contains:

- Date and time of move
- Crossing warning time (**WT**)
- Detection (**Det**) speed
- Island (**Isl**) speed

Each move listing is designated by either an X (crossing) or T (track) to the right of the time entry.

The X is the warning time for the whole crossing. The T is the time that a particular track has seen the train. The X should be referenced for full expected warning time. If the T one shows a short warning time, check the X for the actual crossing warning time.

Maintenance Log

- Combines entries for both Main and Standby
- Stored on the Display module.
- Main and Standby CPU information stored in same log.
- Contains programming changes
- Contains Calibration information

NOTE

The Status Log and Summary Log show fewer events per screen when viewed on the Model 5000 GCP Display module than on the WebUI.

Status Log

- Separate log for Main and Standby
- Contains all system events

Summary Log

- Provides a summary of the significant events from the status log.
- Separate log for Main and Standby (log is stored on the Display module)
- Contains error events.

SYSTEM TROUBLESHOOTING

This subsection describes the method of troubleshooting a problem in a system that has previously been in service. The first step in troubleshooting a problem is to determine whether the components of a 5000 GCP system have detected a problem. When the 5000 GCP system is healthy, it shows the following:

- On the Display module:
 - A red triangle appears on the track status line if a train has been detected.
 - The XR indicator on the bottom right side of the screen is green when the system is healthy and the XR relay has not dropped.
- On the individual modules:
 - Health LEDs on all modules (CPU, Track, RIO, and SSCC IIIi, and SEAR IIi) are flashing slowly (1 Hz).
 - Transfer Module display is not counting down.
 - SEAR Alarm LEDs indicate that no alarms are present.
 - Power LEDs on all modules are on and steady.
- On the CPU Module:
 - CPU LED 1 is lit, indicating that the Maintenance Call output is on.
 - CPU LED 2 is lit, indicating that the transfer signal is being generated.

If the system has detected a problem, use the System Diagnostics or the Track Diagnostics to locate the problem.

Diagnostics

Each module also has diagnostic LEDs, and may have a four-character display, that assists in setup, calibration, diagnostics and troubleshooting. Refer to the Table of Contents at the front of this handbook to locate the exact Module required for LED and four-character display information.

When an unhealthy system or track condition exists, a red warning triangle is displayed. The status line for the affected track also displays a red warning triangle.

System Diagnostics

System Diagnostics Window can be accessed in two ways:

- Select the track by pressing the assigned number key, then select **2) Diagnostics**. The DIAG screen opens, displaying any errors.

Slot	Description	Code
Trk 1	No GCP frequency Selected	1012
Trk 1	GCP Calibration Required	1020
Trk 1	GCP Approach Calibration Required	1021
Trk 1	GCP Linearization Required	1022
Trk 1	No Island Frequency Selected	1300
Trk 1	Island Calibration Required	1305

Figure 14 Diagnostic Screen

- Selecting one of the displayed error descriptions displays the diagnostic detail screen shown below.

ErrCode: 1300-Cause & Remedy
<p>Cause: This message indicates that Island Operation has been requested but no island frequency has been selected</p> <p>Remedy: Select an island frequency from the Program menu</p>

Figure 15 Diag Screen

This screen lists the cause and remedies for the selected error. Use the UP and DOWN buttons as needed to view all of the data.

- The Diagnostic messages can also be accessed via the **Diags & Reports > DIAG** screen.

Troubleshooting the Modules

Use the following tables to troubleshoot the individual modules.

Table 21: Diagnosing CPU Module Problems

Diag Display / Description	Cause	Remedy
ADR ATCS Session address invalid (Diag3015) / The radio DAXing neighbor ATCS address is invalid.	Usually occurs when ATCS Site Address (SIN) is not entered correctly	Reenter ATCS Site Address (SIN)

Table 21: Diagnosing CPU Module Problems

Diag Display / Description	Cause	Remedy
<p>CAP MCF Capability Error (Diag3016) / The CPU is not capable of running this MCF</p>	<p>Usually occurs when using a recent MCF on an old CPU</p>	<p>Purchase a CPU with a higher capability, obtain an MCF requiring lower capability CPU, or update the MEF on the existing CPU to work with the desired MCF.</p>
<p>CCN CCN Incorrect (Diag3021) / The CCN is incorrect for the configuration.</p>	<p>After loading a configuration file, the CCN is incorrect.</p>	<p>Reload the configuration file and repower the CPU card. If error continues, perform Set to Default and reprogram the unit.</p>
<p>CIC CIC Access Error (Diag3022) / CPU unable to access data stored in CIC</p>	<p>If CIC access error is on MAIN CPU</p>	<ol style="list-style-type: none"> 1. Remove Standby CPU and repower unit. 2. If CIC error clears, the Standby CPU is bad; replace bad card. 3. If error does not clear, remove Main CPU, return Standby CPU to original slot, and switch to Standby. 4. If error clears, MAIN CPU is bad; replace card. 5. If error does not clear, CIC is bad; replace GCP chassis.
	<p>If CIC access error is on STANDBY CPU Card</p>	<ol style="list-style-type: none"> 1. Remove Main CPU and repower unit. 2. If CIC error clears, the Main CPU is bad; replace bad card. 3. If error does not clear, remove Standby CPU, return Main CPU to original slot, and switch to Main. 4. If error clears, Standby CPU is bad; replace card. 5. If error does not clear, CIC is bad; replace GCP chassis.

Table 21: Diagnosing CPU Module Problems

Diag Display / Description	Cause	Remedy
CRC MCF/MEF CRC Incorrect / The MCF/MEF CRC is incorrect for the current MCF	MCF CRC entered is incorrect (Diag 3004)	Reload MCF CRC.
	MCF is corrupt (Diag 3003)	Reload the MCF.
	The executive (MEF) file is corrupt. (Diag 3014)	Reload the MEF.
CRPT MCF Checksum Incorrect (Diag3003) / The MCF did not load correctly.	The MCF is corrupt	Reload MCF
DFT Default Values set (DIAG3001) / Operating parameters have been set to default.	New MCF has been loaded	Set the operating parameters to the required values
DFT Vital Cfg Parm set to default (DIAG3002) / Vital Cfg parameters have been set to default.	New MCF has been loaded or UCN changed	Set the Vital Cfg parameters to the required values
DFT Configuration set to default (DIAG3017) / Configuration set to default.	The configuration parameters have been set back to default due to either: <ul style="list-style-type: none"> • MCF change • Template change • User setting default 	Wait. The error will clear itself.
INIT No VLP Comms (DIAG3020) / The VLP/CP LED on the CPU card does not light	The VLP is rebooting or is in its Initial State and performing its initial checks. This may occur after a VLP reset, or after changing templates.	Wait for a minute for the VLP to power up. If the VLP does not power up, check to see if it is continuously rebooting by checking the VLP Health LED.

Table 21: Diagnosing CPU Module Problems

Diag Display / Description	Cause	Remedy
MCF MCF Checks failed (DIAG3005) / Verification of MCF data failed.	The MCF is invalid.	Obtain and load a valid MCF.
MCF MCF Compatibility incorrect (DIAG3013) / MCF and MEF are incompatible	The installed MCF is incompatible with the MEF software	Obtain compatible MCF or MEF software
MCF Incompatible SEAR / MCF Combination (DIAG6001) / MCF and SEAR MEF are incompatible	The GCP MCF loaded is not compatible with the SEAR Executive.	Load the 9V725 SEAR Executive or a newer MCF.
MCF Incompatible SEAR / MCF Combination (DIAG6002) / MCF and SEAR MEF are incompatible	The GCP MCF loaded is not compatible with the SEAR Executive.	Load the 9VC25 SEAR Executive or an older MCF.
MOD Module Type Error (DIAG3006) / The MEF software is incompatible with the module hardware.	The MEF is incompatible with this hardware.	Reload a valid MCF for this hardware.
UCFG VLP Unconfigured (Diag3018) / VLP is unconfigured and not communicating with I/O modules	Usually due to: <ul style="list-style-type: none"> • Incorrect MCF CRC; • MCF not loaded • MCF not stored in ECD (ECD replaced); • No ATCS Site ID (SIN) entered for Vital Comms application 	Check other diagnostic message for exact cause.

Table 22: Track Module Indications (Module States)

Indication	Meaning	Module State
CHK1	The receive wire EZ reading is very low in comparison with the check wire EZ	All predictors are de-energized
CHK2	The check wire EZ reading is very low in comparison with the receive wire EZ	All predictors are de-energized
CHK3	The receiver and check wires have low reading (train at EZ=0), but island is not occupied. (Only shows when GCP and Island share same pair of transmit wires).	All predictors are de-energized
CHK4	The check wire and receive wire readings are more than 50 points different	All predictors are de-energized
CKEX	The check wire phase is incorrect	All predictors are de-energized
GAPP	GCP Approach Calibration is required	All predictors are de-energized
GCAL	GCP Calibration is required	All predictors are de-energized
GEXP	GCP detected decreasing phase which could be a bad bond	All predictors are de-energized
GFRQ	GCP frequency not set	All predictors are de-energized
GHWR	GCP hardware error	All predictors are de-energized
GIPS	Enhanced detection is turned on and the GCP detects poor shunting	Prime and Preempt de-energized (any zero offset predictors)
GLCK	EZ or check EZ is below 3 after GCP has booted up Refer to the Trouble-shooting section	All predictors are de-energized
GLIN	GCP Linearization Calibration is required	All predictors are de-energized
GMAX	GCP module does not support MAX transmit level Set transmit level to Medium or High Change Module to A80418 newer than rev D	All predictors are de-energized
GOFS	MS/GCP Operation is Out of Service	All used predictors are energized All unused predictors are de-energized

Table 22: Track Module Indications (Module States)

Indication	Meaning	Module State
GPRM	The Track Module is configured to expect an island and the prime has a non-zero offset value Set the prime to zero offset, if applicable If island is used at remote location, use a DAX not the prime Set the Island Connection to No Islands if no island is intended	All predictors are de-energized
GRCV	GCP receiver error	All predictors are de-energized
GSLV	GCP slaving error	No effect on predictors
GSTB	GCP is stabilizing after transmitter was turned on	All predictors are de-energized
GXMT	GCP transmitter error	All predictors are de-energized
HIEZ	High EZ (>115) detected on main or check wires	All predictors are de-energized
ICAL	Island Calibration is required	Island is de-energized
ICON	Island Connect Error. The GCP Island Connection indicates an island is connected, but no island is turned on.	All predictors are de-energized
IFRQ	Island frequency not set	Island is de-energized
IOFS	Island Operation is Out of Service	Island energized
ISTB	Island is stabilizing after transmitter has been turned on	Island de-energizes
ITST	Island has detected a possible interfering signal	No effect on Island occupancy
IXMT	Island transmitter error	Island de-energizes
LWEX	Low EX detected Low EX Adjustment is usually 39	All predictors are de-energized
LWEZ	Low EZ detection is turned on and EZ has remained below the low detection level for longer than the low EZ detection time.	All predictors are de-energized
RECV (RE-COVERY)	The GCP is running a 30 second Recovery Time-out after an error has cleared.	All predictors are de-energized
RECV (RE-COVERY)	The Island is running a 30 second Recovery Time-out after an error has cleared.	Island is occupied
RXEX	The receive wire phase is incorrect	All predictors are de-energized

Table 22: Track Module Indications (Module States)

Indication	Meaning	Module State
UCFG	Track module is unconfigured	All predictors are de-energized; Island is de-energized; Outputs are de-energized; Inputs are de-energized
VOER OUT	Output hardware failure detected. Output is commanded on but is detected as off	Failed output(s) de-energized
VERS	This is shown when a track module of Rev D or Rev L running software earlier than gcp04_70.mef is loaded in a GCP5000 that uses gcp5k-trc-02-3.mef (see table below that shows compatibility with Rev D / L)	Replace with a Rev L with software gcop04_80.mef or later.

If the GCP 5000 uses an MCF with 'trc' in the name (trc = Track Rev Check), such as gcp5k-trc-02-3.mcf, the system will not allow Rev D or earlier track modules to be used, and will display an unhealthy state if a Rev D Track Module is present. As the system enforces the use of Rev L, the ferrite beads are not necessary on the track wires, as these are present on the Rev L track modules. The following table shows the diagnostic messages that are observed for various combinations of MEF and MCF.

Table 23: Track Hardware Errors

CPU- VLP SW	GCP Track SW	GCP Track HW	Diagnostic messages
Vph05_10	Gcp04_70	Rev L	Healthy works fine, no errors, log msgs
Vph05_10	Gcp04_70	Rev D	Diag msg: Trk 1: Track Card Incompatible (Diag 1307) Log msg: Track 1 Module Unhealthy Track 1 Hardware older than rev L in slot 2 Trk card four char display msg: VERS
Vph05_10	Older than Gcp04_70	Rev L	Diag msg: Trk 2: Track Card Incompatible (Diag 1307) Trk 2: No Communications (Diag 1017) Log msg: Track 2 Module Unhealthy Track 2 Hardware older than rev L in slot 3 Trk card four character display msg: VERS/UCFG

CPU- VLP SW	GCP Track SW	GCP Track HW	Diagnostic messages
Vph05_10	Older than Gcp04_70	Rev D	Diag msg: Trk 2: Track Card Incompatible (Diag 1307) Trk 2: No Communications (Diag 1017) Log msg: Track 2 Module Unhealthy Track 2 Hardware older than rev L in slot 3 Trk card four char display msg: VERS/UCFG
Older than Vph05_10	Gcp04_70	Rev L	Healthy works fine, no errors, log msgs
Older than Vph05_10	Gcp04_70	Rev D	Diag msg: Trk 1: Track Card Incompatible (Diag 1307) Log msg: Track 1 Module Unhealthy Track 1 Hardware older than rev L in slot 2 Trk card four char display msg: VERS
Older than Vph05_10	Older than Gcp04_70	Rev L	Diag msg: Trk 2: No Communications (Diag 1017) Log msg: none Trk card four char display msg: VERS / UCFG
Older than Vph05_10	Older than Gcp04_70	Rev D	Diag msg: Trk 2: No Communications (Diag 1017) Log msg: none Trk card four char display msg: VERS / UCFG

Table 24: Track Module Indications (Remedies)

Panel Indication – Diagnosis	Description	Cause	Remedy
CHK1 Gain Check – Receive Wire Error (Diag1008)	Receive signal level is low while check signal level is normal. Check EZ is normal and track EZ is very low value	High resistance or open connection in a receive wire.	Locate and repair open connection in the receive wires

Table 24: Track Module Indications (Remedies)

Panel Indication – Diagnosis	Description	Cause	Remedy
CHK2 Gain Check – Check Wire Error (Diag1007)	Check signal level is low while transmit and receive levels are normal. Check EZ is very low while track EZ is normal value	High resistance or open connection in a check wire.	Locate and repair high resistance or open connection in check wires.
CHK3 Gain Check Island Error (Diag1009)	The receiver and check wires have low reading (train at EZ=0), but island is not occupied. (Only shows when GCP and Island share same pair of transmit wires).	Poor connection of receive/check wires or poor shunting or bad calibration data.	Locate and repair high resistance or open connection in check/receive wires. Recalibrate island.
CHK4 Gain Check Error (Diag1010)	Receiver and check signal levels differ by a significant amount	If a train is present: <ul style="list-style-type: none"> • High resistance in transmitter track wires 	Locate and repair: <ul style="list-style-type: none"> • High resistance connections in transmitter track wires
CHK4 Gain Check Error (Diag1010)	Receiver and check signal levels differ by a significant amount	If no train is present: <ul style="list-style-type: none"> • High resistance in receiver or check receiver track wires • open track connection 	Locate and repair: <ul style="list-style-type: none"> • High resistance connections in receive or check track wires • open connections in receive or check track wires

Table 24: Track Module Indications (Remedies)

Panel Indication – Diagnosis	Description	Cause	Remedy
CKEX Check Wire EX Error (Diag1006)	Check wires and transmit wires are out of phase Generally occurs at cutover with 6-wire installations	The check wires and transmit wires are misphased.	Change the check wires connections so that: T1 & C1 are tied together T2 and C2 are tied together
GAPP GCP Approach Calibration Required (Diag1021)	GCP Approach Calibration Required	Approach is uncalibrated An approach reverts to its uncalibrated state when the: GCP is recalibrated Track Module is replaced Template is set to default or a new template is selected Programmed approach distance is changed MCF is changed	Access the appropriate GCP Calibration Window If the computed approach distance is correct, select the BYPASS button If the computed approach distance is known for this track from a previous calibration, enter the correct value by selecting the EDIT button. If the computed approach distance is incorrect and is unknown, perform the approach calibration as described in Table 11.

Table 24: Track Module Indications (Remedies)

Panel Indication – Diagnosis	Description	Cause	Remedy
GCAL GCP Calibration Required (Diag1020)	GCP Calibration Required	The Track Module is uncalibrated. A Track Module reverts to its uncalibrated state when the: Track Module is replaced MCF software is changed Template is set to default or a new template is selected Track Frequency is changed Approach distance is changed Compensatio n value is changed Transmit level is changed Directional (bi/uni) mode is changed	Access the appropriate Calibration Select Window and calibrate the GCP as described in Table 9.
GEXP EX Process Error (Diag1016)	Phase (EX) decreases as train approaches crossing	Possibly caused by: poor shunting high resistance bond generally located near the GCP track wires	Locate and repair high resistance bonds
GFRQ No GCP frequency Selected (Diag1012)	No track frequency set	MS/GCP Operation has been programmed as ON, but no GCP frequency has been selected	Select a GCP frequency from the GCP: track n program menu

Table 24: Track Module Indications (Remedies)

Panel Indication – Diagnosis	Description	Cause	Remedy
GHWR Track Hardware Error (Diag1019)	Track Hardware Error	This occurs when the Track Module detects that its hardware is not operating correctly	Replace the module
GIPS IPS Mode (Diag1013)	Inbound poor shunting (IPS) detected	IPS Mode is shown when the Track Module is configured with the Enhanced Detection option On and the module detects inbound poor shunting	None
GLCK Power Up Lockout Error (Diag1018)	EZ or Check EZ low after reboot	The EZ or Check EZ values are less than three after a power up. This could be caused by a train shunting the tracks near the feed point open receive or check wires	If a train is present, clear the lockout by: <ul style="list-style-type: none"> • Select the Track • When the Track Options window opens, select 7) Release Track If no trains are present, clear the lockout by: <ul style="list-style-type: none"> • repair the check and/or receive wires as required.

Table 24: Track Module Indications (Remedies)

Panel Indication – Diagnosis	Description	Cause	Remedy
GLIN GCP Linearization Required (Diag1022)	GCP Linearization Calibration Required	Linearization is uncalibrated Linearization reverts to its uncalibrated state when the: GCP is recalibrated Track Module is replaced Template is set to default or a new template is selected Programmed approach distance is changed MCF is changed	Go to the Setup Track Linearization Screen. If the linearization value is correct, select the BYPASS button. If the linearization value is known for this track from a previous calibration, enter the correct value by selecting the EDIT button. If the linearization value is incorrect or not known perform a linearization calibration as described in Table 11.
GMAX Transmitter Error (Diag1202)	GCP module does not support MAX transmit level	GCP module does not support MAX transmit level	Set transmit level to MED or HIGH. Change Transmit Module to A80418 newer than rev D.
GOFS Out of Service Error	MS/GCP Operation is Out of Service	GCP module is taken Out of Service	Return GCP to service by either using display or input
GPRM Program-Error (Diag1202)	The Track Module is configured to expect an island and the prime has a non-zero offset value	Prime is set not set to zero.	Set the prime to zero offset, if applicable. If island is used at remote location, use a DAX not the prime. Set the Island Connection to NO Islands if no island is intended.

Table 24: Track Module Indications (Remedies)

Panel Indication – Diagnosis	Description	Cause	Remedy
GRCV Receiver Error (Diag1014) or (Diag1015)	Track Module internal receiver channels differ	Unacceptable difference between the redundant receivers on the Track Module is detected	Replace Track Module
GSLV GCP Slave Signal Error (Diag1023)	Slaving Error	The Track Module is not receiving clock sync from the Primary Track Module. The primary Track Module is normally the module in the Track 1 Slot.	If only one Track Module is reporting the error, replace that module. If all Track Modules are reporting the error, replace the primary Track Module (generally T1).
GSTB GCP Stabilizing (Diag1001)	20 sec. stabilization period prior to start of normal operation.	System startup	Wait
GSWR Software Compatibility Error (Diag1201)	Software is incompatible between Track Card MEF and CPU MCF.	The software (MEF) in the Track Card is incompatible with the MCF running in the CPU	Install: <ul style="list-style-type: none"> • Latest track Module MEF • Latest MCF
GXMT Transmitter Error (Diag1011)	Transmitter cannot maintain a constant current	All installation: <ul style="list-style-type: none"> • High resistance or open transmit track wire • High resistance or open track wire rail connection 	Locate and repair open transmit wires or high resistance transmit wires connections.

Table 24: Track Module Indications (Remedies)

Panel Indication – Diagnosis	Description	Cause	Remedy
GXMT Transmitter Error (Diag1011)	Transmitter cannot maintain a constant current	Unidirectional installations only: <ul style="list-style-type: none"> • open termination • open coupler • open bond 	Locate and repair: <ul style="list-style-type: none"> • open termination • open coupler • open bond
HIEZ High EZ (Diag1002)	High EZ or high EZ check value detected	Ballast has increased significantly since calibration	Recalibrate only after verifying that no other cause exists.
HIEZ High EZ (Diag1002)	High EZ or high EZ check value detected	Broken rail	Repair broken rail
HIEZ High EZ (Diag1002)	High EZ or high EZ check value detected	Defective insulated joint coupler	Replace defective insulated joint coupler
HIEZ High EZ (Diag1002)	High EZ or high EZ check value detected	Defective termination shunt	Repair defective termination shunt
HIEZ High EZ (Diag1002)	High EZ or high EZ check value detected	High resistance termination shunt connection	Repair high resistance connection to termination shunt
HIEZ High EZ (Diag1002)	High EZ or high EZ check value detected	High-resistance track bond wire connection	Repair high resistance bond
HIEZ High EZ (Diag1002)	High EZ or high EZ check value detected	Poor calibration	Recalibrate only after verifying that no other cause exists.

Table 24: Track Module Indications (Remedies)

Panel Indication – Diagnosis	Description	Cause	Remedy
ICAL Island Calibration Required (Diag1305)	Island requires calibration	Calibration is required when the: Track Module is replaced MCF is changed Template is set to default or a new template is selected Island frequency is changed	Access the appropriate Calibration Select Window and calibrate the island as described in Table 12.
ICON Island Connect Error (Diag1203)	The GCP Island Connection indicates that an island is connected, but no island is turned on.	Faulty programming Bad Connection	Verify programming against plan. Check Island wiring
IFRQ No Island Frequency Selected (Diag1300)	No island frequency has been programmed	An Island Operation is requested but no island frequency is selected	Select an island frequency from the Program menu
ISTB Island Stabilizing (Diag1301)	Island stabilizing after a power up	On startup the Track module initiates a 20 second timeout to allow the island output to stabilize	Wait
ITST Island Self Test Error (Diag1302)	Variations in the island receive frequency	An interfering signal is causing large variations in the Island receive signal	Change island frequency
ITST Island Self Test Error (Diag1302)	Variations in the island receive frequency	Defective Track Module	Replace the Track Module

Table 24: Track Module Indications (Remedies)

Panel Indication – Diagnosis	Description	Cause	Remedy
IXMT Island Transmitter Error (Diag1304)	Island cannot supply a constant current	All installations Track Module detects: high resistance transmit track wire open transmit track wire high resistance or open track wire rail connection	Locate and repair defective wiring or connections
IXMT Island Transmitter Error (Diag1304)	Island cannot supply a constant current	Unidirectional installations Track Module also detects open bond	Locate and repair open termination, joint coupler, or bond
LWEX Low EX (Diag1003)	Low track ballast resistance detected.	Broken rail	Repair broken rail
LWEX Low EX (Diag1003)	Low track ballast resistance detected.	Low ballast	Determine cause of low ballast and compensate
LWEX Low EX (Diag1003)	Low track ballast resistance detected.	Low ballast and defective insulated joint coupler	Replace defective insulated joint coupler
LWEX Low EX (Diag1003)	Low track ballast resistance detected.	Low ballast and high resistance bond	Repair high resistance bond
LWEX Low EX (Diag1003)	Low track ballast resistance detected.	Mud or other contaminants within ballast	Verify EX Adjust as described in Table 29
LWEX Low EX (Diag1003)	Low track ballast resistance detected.	Poor drainage at crossing	Temporarily shorten the approach (see WARNING)
LWEX Low EX (Diag1003)	Low track ballast resistance detected.	Salted crossing	Use a lower GCP frequency
LWEZ Low EX (Diag1004)	Low EZ Detection is programmed ON and its timer interval is exceeded.	A false shunt on the track	Remove false shunts from the track. Check that EZ returns to normal after false shunt removal.

Table 24: Track Module Indications (Remedies)

Panel Indication – Diagnosis	Description	Cause	Remedy
LWEZ Low EX (Diag1004)	Low EZ Detection is programmed ON and its timer interval is exceeded.	A train is on the approach for a time longer than the timer setting.	Temporarily turn off low EZ detection until train has left.
LWEZ Low EX (Diag1004)	Low EZ Detection is programmed ON and its timer interval is exceeded.	Open receive track wire	If false shunt is not found, refer to the diagnostics messages for open receive wire.
LWEZ Low EX (Diag1004)	Low EZ Detection is programmed ON and its timer interval is exceeded.	Open receive track wire	Repair
RECV GCP Recovering (Diag1000)	30 sec. recovery time-out	Clearing of system error	Wait
RECV Island Recovering (Diag1303)	Island recovering after self-test	The Track module initiates a 30- second recovery timeout after an island error has cleared.	Wait
RXEX Receive Wire EX Error (Diag1005)	Transmit and receive wires are out of phase Generally observed at cutover	The receive and transmit wires are connected to the wrong rail (misphased)	Change the track wire connections so that: T1 & R1 are connected to rail 1 T2 & R2 are connected to rail 2
UCFG No Communications (Diag1017)	No communi- cation to a Track Module.	Track Module is not commu- nicating with the CPU.	Verify that a module is in appropriate slot

Table 24: Track Module Indications (Remedies)

Panel Indication – Diagnosis	Description	Cause	Remedy
UCFG No Communications (Diag1017)	No communication to a Track Module.	Track Module is not communicating with the CPU.	Replace the module if the Track Module is continuously rebooting. BOOT displays on 4-character display at one minute (approximate) intervals.
UCFG No Communications (Diag1017)	No communication to a Track Module.	Track Module is not communicating with the CPU.	If the Track Module is not continuously rebooting determine if UCFG is shown on the module's display. If only this module displays UCFG, replace it if all Track Modules display UCFG replace the CPU Module
VOER OUT Correspondence Check Error (Diag1200)	No Vital output voltage	A vital output is commanded to be on, but is producing no voltage. May be caused by: Open or shorted output Defective Track Module.	Check for an open or shorted output and repair as required. If the output is not open or shorted, replace the Track Module

Table 24: Track Module Indications (Remedies)

Panel Indication – Diagnosis	Description	Cause	Remedy
Track Card Incompatible (Diag1307)	Track module requires software update	This is shown when a track module of Rev D or Rev L running software earlier than gcp04_70.mef is loaded in a GCP5000 that uses gcp5k-trc-02-3.mef (see table below that shows compatibility with Rev D / L)	Replace with a Rev L with software gcop04_80.mef or later.

Table 25: Diagnosing SSCC Module Problems

Diag Display / Description	Cause	Remedy
Crossing Bank Failure (Diag2001) / SSCC Illi module lamp drive output failure	Lamp driver bank A has failed.	Replace the SSCC Illi module
Lamp Neutral Wire Open (Diag2002) / The SSCC Illi has detected open lamp neutral wire	Lamp neutral wire is open	Repair open neutral wire to lamps
Low Battery Warning (Diag2003) / SSCC Illi detected low battery voltage	Battery voltage is below the programmed Low Battery Detection level. This may be caused by:	
	Incorrect Low Battery Detection Level setting	Correct Low Battery Detection Level setting:
	Defective battery charger operation	Perform battery charger maintenance
	Defective Battery operation	Perform battery maintenance
Lamp Voltage Limited (Diag2005)	Lamp voltages are set above the battery terminal voltage.	Reduce the lamp voltages to be less than the battery voltage
No Communications	SSCC Illi Module in wrong slot	Move Module to appropriate slot.

Table 25: Diagnosing SSCC Module Problems

Diag Display / Description	Cause	Remedy
(Diag2017)	SSCC IIIi Module defective. Indicated by: POWER light is off HEALTH LED is off for 10 seconds and then on for 10 seconds (module continuously reboots). HEALTH LED flash at fast rate (other modules function properly)	Replace SSCC IIIi Module
	CPU Module defective. Track Module displays read UNFG HEALTH LEDs of all modules flash at 2 Hz rate	Replace CPU Module

SSCC IIIi Notes:

The SSCC IIIi module performs a self-diagnostic on each train move.

Where only LED lamps are used, a false lamp-neutral-wire-open condition may be detected when Lamp Neutral Test is set to On.

To avoid a false error indication set the Lamp Neutral Test status entry for each active crossing controller to Off.

Effective with Revision D of the SSCC IIIi, FLASH SYNC is an isolated two-wire output.

If two Revision D or later SSCC IIIi units in the same chassis are operated by separate batteries, the FLASH SYNC returns are connected internally and no additional connection is required.

Revision D SSCC IIIi Modules can be identified by:

- “D” located at end of Part Number / Bar Code tag on the surface of the circuit board.
- Large metal bracket located on component side of module.

When using Revision C SSCC IIIi or earlier, or when external SSCC units are connected to a master SSCC IIIi and operated from a different battery, the following wiring must be provided for FLASH SYNC Return:

- If two Revision C SSCC IIIi units in the same chassis are operated by separate batteries, the N pins of the SSCC IIIi power and lamp connectors must be wired together.
- If an external SSCC IIIA, SSCC III PLUS, or SSCC IV is connected to a master SSCC IIIi:
- If the SSCC IIIi is Revision C or earlier, the negative terminals of the master SSCC IIIi and external SSCC must be wired together.
- If the SSCC IIIi is Revision D or later, the SSCC IIIi FLASH SYNC return (-) must be connected to N on the external SSCC.

The terminology for flash sync control differs between a Model 5000 GCP and an external SSCC device. The Model 5000 GCP terms Master and Slave SSCC, are called “Flash Sync Out” and “Flash Sync In” respectively in an external SSCC (Master = Flash Synchron Out, Slave = Flash Sync In).

Lockout & Release Track

When problems exist at initial startup or when transferring to or from MAIN and STBY, a ‘LOCKOUT’ message is displayed as an added precaution during power up.

Either scroll to Diags & Reports and select **1) DIAG**, or from **System View > #) Track > 2) Diagnostics**.

The Diag Screen will open displaying any error descriptions. Select any depicted error and a new screen displays possible causes and remedies for that error.

If a train is present during power up, select the affected track, and when the Track “N” Options window opens, select **7) Release Track**.

After the cause of the power-up lockout problem is corrected, the system releases lock when EZ goes up. The Model 5000 GCP is programmed with self-diagnostic causes and remedies for most common problems. Accessing the information is similar to the method above.

Diagnostics Log

The diagnostic log provides a time and date stamp of all previous errors. Scroll to Diags & Reports, select **3) Reports & Logs > 2) Logs > then 2) Diagnostic Log**.

Use the scrolling arrows to scroll to the Start Date, and then press **Enter**. Select the date by using the number keys and then scroll to Start Time and select. Then select **Show Diagnostic Log**.

- Can be used to provide important information for intermittent track or equipment problems.
- Log is stored in the USB ECD behind the Display module.
- Captures events only while the Display module is connected to the GCP.

Refer to the Troubleshooting Flow Chart, on Figure 16 Page 80 and Figure 17 on Page 81, to assist in system and track problem diagnosis.

Maintenance Call Lamp Output

NOTE

When energized, the MAINT CALL lamp output completes the circuit to the negative CPU battery. A MAINT CALL light can be connected between “B” and MAINT CALL. A series limiting resistor should be used to lower voltage across the lamp and limit the total current to 4 amps.

The Maintenance Call feature can provide an additional level of diagnostics. When the 5000 GCP system is healthy, the maintenance call output is energized.

The maintenance call output de-energizes when:

- The SEAR Ili application program detects low voltage, power off indication or other custom conditions in the railroad specific application program.
- The CPU detects a battery voltage less than the programmed and enabled low battery threshold.
- An enabled SSCC Ili module is unhealthy.

- An enabled SSCC Illi module with low voltage detection “On” detects a battery voltage less than the programmed low battery threshold.
- The maintenance call repeater input is enabled and the maintenance call input is low.
- The maintenance call output is low when using SSCC IV and it detects low battery or vehicle detect health input is used and it is low
- Out of Service inputs are used and they are energized
- SEAR is used but not in session with GCP CPU

Transfer Output

When the 5000 GCP system is healthy, the transfer output is energized (on) as shown by LED2 lit on the active CPU module.

- This output level stops the Transfer Module from counting down and transferring to the opposite side when the Transfer Module is in the auto mode.

The transfer output is de-energized (off) when:

- A module is programmed as used but is not communicating with the CPU.
- MS/GCP or Island operation on a Track Module is unhealthy.
- The module cannot provide the 12-volt output.

Troubleshooting information regarding each module may be found at: CPU Module: Table 21, Track Module: Table 22, and Table 24, SSCC Illi Module Table 25

Troubleshooting Flowchart

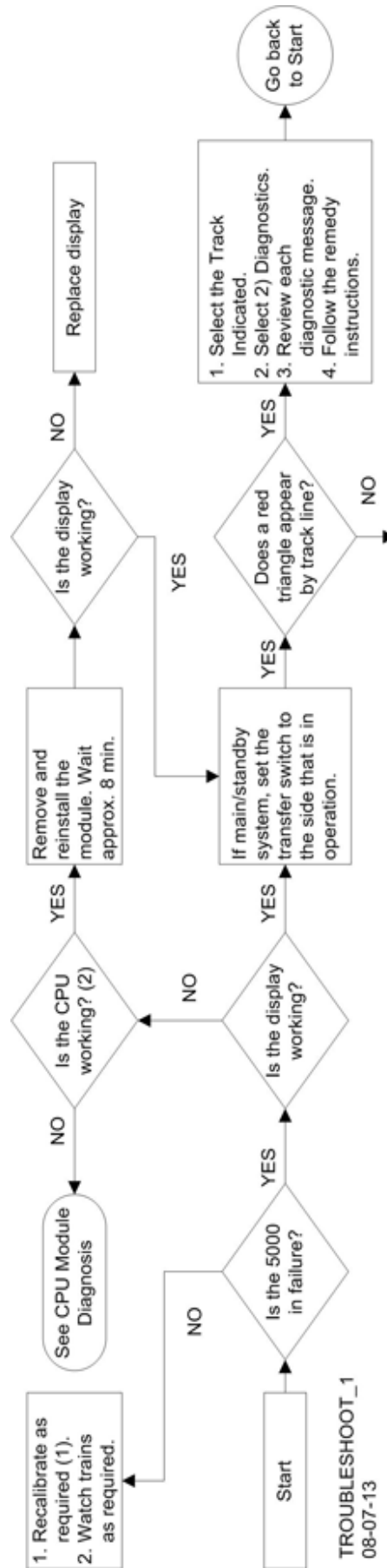

Figure 16: Troubleshooting Flowchart (Part 1)

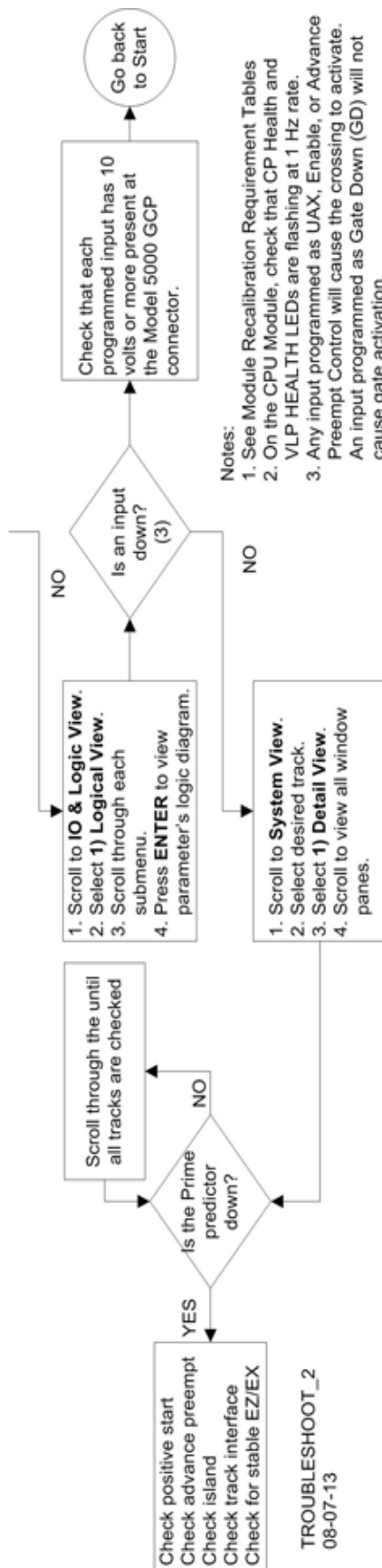

Figure 17: Troubleshooting Flowchart (Part 2)

TESTING TRACKSIDE EQUIPMENT

Test trackside equipment as per the steps listed below:

Testing Insulated Joint Couplers

Table 26: Insulated Joint Coupler Test

Step 1	Connect a hardwire shunt on the crossing side of the joint coupler.
Step 2	Note the EZ value: _____
Step 3	Move the hardwire shunt to the termination side of the joint coupler.
Step 4	Note the EZ value: _____
Step 5	Remove the hardwire shunt.
Step 6	<p>Note the EZ values difference in Steps 2 and 4.</p> <ul style="list-style-type: none"> Wideband shunt coupler - if the difference in EZ is more than 2, the wideband shunt is defective. <p>Verify that EX does not drop coming across the couplers moving toward the crossing. If it does, re-tune the couplers per Tuning the 62785-f Tuned Joint Coupler.</p> <ul style="list-style-type: none"> Tuned Insulated Joint Coupler, TIJC - (located in the outer half of the approach), if the EZ difference is more than 3, the TIJC is mistuned or defective.

Testing Rail Bonds

Table 27: Rail Bond Test

Step 1	Note the EX value with no shunt _____
Step 2	Place a hardwire shunt at the 50% point of the approach.
Step 3	Note the EX value: _____
Step 4	<p>Note the difference in EX values in Steps 1 and 3. An EX value always increases as a shunt is placed closer to the crossing.</p> <p>If the EX value recorded in Step 3 is greater than the EX value in Step 1, the bad bond is between the hardwire shunt and the termination.</p> <ul style="list-style-type: none"> If the EX value recorded in Step 3 is lower than the EX value in Step 1, the bad bond is between the hardwire shunt and the crossing.
Step 5	<ul style="list-style-type: none"> Continue placing the hardwire shunt closer or further away from the starting point, based on the value in Step 3. When the EX value increases, the last bond passed is the bad bond.

EZ must be greater than 15 for this test to work.

Testing Termination Shunts (Hardwire, Wideband and Narrow Band (NBS))

Table 28: Termination Shunt Test

Step 1	Note the EZ value _____
Step 2	Install a hardwire shunt across the termination.
Step 3	Note the change in EZ: _____ If termination is hardwire, no EZ change occurs. If termination is wideband, an EZ change of no more than ± 2 occurs. If termination is NBS, EZ can decrease up to 30. Lower frequencies and shorter approaches produce a greater change. <ul style="list-style-type: none">• If termination is NBS and an increase in EZ is noted, then the NBS is defective.

TESTING FOR TRACK CIRCUIT ISSUES

Track Circuit Problems

When a failure occurs in a bi-directional GCP track circuit, the EZ and CHECK EZ on the Detailed Status View will generally change in relationship to the normal range and possibly to each other as follows:

- If EZ and Check EZ move higher or lower than normal, but remain relatively equal to each other, the track circuit problem lies on the transmitter side of the crossing.
- If EZ and Check EZ move higher or lower than normal, but their values differ by more than 5, the track circuit problem most likely lies on the receiver side of the crossing.

Low EX

A Low EX condition exists when EX is below 39.

If a low EX condition is occurring at a cutover of a new installation, check the following:

- Defective Bonds
- Defective insulated joint couplers
- Missing battery choke in approaches
- Defective gauge rods or switch rods
- Open termination shunt
- Improper application of other frequency NBS in the approaches.

When low EX occurs at an in-service crossing, follow the steps shown in Table 29 to determine whether the Low EX Adjustment can safely be lowered below 39.

- Low EX condition commonly occurs at an in-service crossing when track conditions are extremely wet and possibly salted.



Do not lower the low EX adjustment below 39 if there is not a 5 point drop in EZ.

Table 29: Low EZ Qualification Test

Step 1	With EX below 39, connect a hardwire shunt at the termination shunt of the longest approach.
Step 2	Record the EZ value: _____
Step 3	Move the hardwire shunt in to the 90% point of the approach.
Step 4	Record the EZ value: _____ <ul style="list-style-type: none"> • If the EZ value at the 90% point is at least 5 less than the EZ value at the termination shunt (Step 2), the Low EX Adjustment can safely be lowered below 39, proceed to Step 5. • If the EZ values do not drop 5 points, the Low EX Adjustment cannot be safely lowered below 39. <ul style="list-style-type: none"> • Do not continue.
Step 5	Scroll to Program View > 8) GCP Miscellaneous . The TRK “N”: GCP Miscellaneous screen opens
Step 6	Press Enter to select the Low EX Adjustment value. The Low EX Adjustment screen opens.
Step 7	Enter a new EX value between 34 and 39, press Enter. The new value appears as the Low EX Adjustment entry value
Step 8	Press the BACK button until Program View appears again.

Nuisance Activation – Rail Phase Check

In situations where EZ shifting between 5 to 20 points concurrently with EX is shifting from 2 to 5 points, checking the rail to ground voltage is required. From within the enclosure at the terminal block, measure the AC voltage from RCV1 to ground, and then measure the AC voltage from RCV2 to ground. The ideal measurement is identical. When V_{RCV1} differs from V_{RCV2} by approximately 0.75V or higher, nuisance activations may occur. Typically, the cause of this problem is a failing insulating joint or arrestor in the signal block.

Table 30: Nuisance Activation Rail Phase Check

Step 1	V_{RCV1} to ground value: _____ VAC
Step 2	V_{RCV2} to ground value: _____ VAC
Step 3	Note the difference: _____ VAC Ideally, the difference is 0 VAC. When V_{RCV1} differs from V_{RCV2} by approximately 0.75V or higher, nuisance activations may occur. Typically, the cause of this problem is a failing insulating joint or arrestor in the signal block



Do not use a narrow band shunt to replace a defective coupler.



Following installation of dual couplers or dual shunts around insulated joints, verify proper operation of the track circuit prior to placing it into operation.

Troubleshooting A De-energized Predictor

This subsection describes the method of troubleshooting a problem in a system that has previously been in service. The first step in troubleshooting a problem is to determine whether the GCP track circuit continuity and components of a 5000 GCP system are healthy.

When the 5000 GCP system is healthy it shows the following:

- Track windows:
 - Have no trouble icons present on Display module
 - have no calibration required messages on Display module
 - System Status bar on Status Screen is green
 - Health LEDs on all module (CPU, Track, RIO, SSCC IIIi) are flashing slowly (1HZ)
- Transfer Module display time is not counting down
- SEAR Alarm LEDs indicate that no alarms are present
- CPU LED 1 is lit, indicating that the Maintenance Call output is on
- CPU LED 2 is lit, indicating that the transfer signal is not allowing transfer
- Power LEDs on all modules are on and steady

If the system is unhealthy use the System Diagnostics or the Track Diagnostics to locate the problem.

Refer to the Troubleshooting Flow Chart, Figure 16 and Figure 17, to assist in system and track problem. If the track module is healthy, predictors can be de-energized for the following reasons:

Table 31: Troubleshooting a De-energized Predictor

Reason	How
The track module senses that EZ is decreasing at a rate that is fast enough to trigger the prediction.	An approaching train.
The predictor (usually Prime and Preempt) has a zero offset distance and the island used by the MS/GCP is de-energized	If the Island LED on the Track Module is off the island is de-energized.
The predictor is running its pickup delay	If the Track Module LED for this predictor is flashing or the Track Detail View shows an hour glass symbol for the predictor, the predictor is running its pickup delay. <ul style="list-style-type: none"> • If the predictor does not recover after its programmed pickup delay time, it should be treated as de-energized.

Table 31: Troubleshooting a De-energized Predictor

Reason	How
Positive Start is enabled and the EZ level is below the programmed Positive Start EZ Level	Positive start is de-energizing the predictor. Enabled in the GCP: track n pos start program menu. Predictor remains de-energized while the EZ is less than the positive state level plus 5. <ul style="list-style-type: none"> The current Track Module EZ is shown on the module's 4-character display and the Track Window of the Status Screen.
An UAX input is de-energized	A UAX input is programmed for the Track Module and the input is not energized or is running UAX Pickup delay.
A DAX Enable input is de-energized	A DAX Enable input is programmed for the Track Module and the input is not energized or is running DAX Enable Pickup delay.
A Preempt Health input is de-energized	A Preempt Health input is programmed for the Track Module and the input is not energized.
Interference is causing large EZ fluctuations which appear to be an approaching train	The rapid fluctuation of the displayed track EZ level by 5 to 10 points (or more) indicates the presence of interference.

High EZ and Low EX History & Calibrated Approach

Review of the high EZ and low EX history (HEZ LEX) and the Computed Approach distance for a track can assist in troubleshooting efforts. The HEZ and LEX values are useful in determining when the EZ was high and when the EX was low.

To review the information:

- From the **System View** screen, select the number of the Track to review.
- When the **Track “N” Options** window opens, select **1) Detail View**. The **Module Details** window opens.
- Press the **Left Arrow** once to view the screen showing the HEZ LEX. Record the HEZ value (_____) and the LEX value (_____).
- Press the **Left Arrow** three times more to view the screen showing the Computed Distance. Record the Computed Distance (_____).

The maintainer may reset the HEZ LEX information after review.

Troubleshooting A Physical 5000 GCP Input

NOTE

Removal of DC power from the Model 5000 GCP case is not required before removing or installing modules. Prior to removing SSCC IIIi modules, remove load from system by opening the lamp, gate control, GP/GD inputs and bell circuits on the surge panel(s). After replacing or re-installing SSCC IIIi modules, replace the load by closing the lamp, gate control, GP/GD inputs and bell circuits on the surge panel(s).

To determine the status of the physical inputs and outputs, scroll to IO & Logic View. The following options are available:

- 1) Logical View
- 2) IN
- 3) Out
- 4) System States

Selecting 1) Logical View allows review of the following areas:

- 1) AND – This displays the ANDs and ENABLEs currently programmed.
- 2) OR – This displays the ORs currently programmed
- 3) Internal States – This displays any Internal IO currently programmed
- 4) System States – This displays system states, most often the MAINT CALL output. The status of Simultaneous Preempt Output is shown as Sim Preempt. Similarly, the status of Advance Preempt Output would be shown as Adv Preempt and the Preempt Health Input is shown as Preempt Hlth input.

I/O & Logic View Screen

The I/O and Logic View menu provides users with the status of all I/Os on the Model 5000 GCP as well as some other general indications for other high-level states.

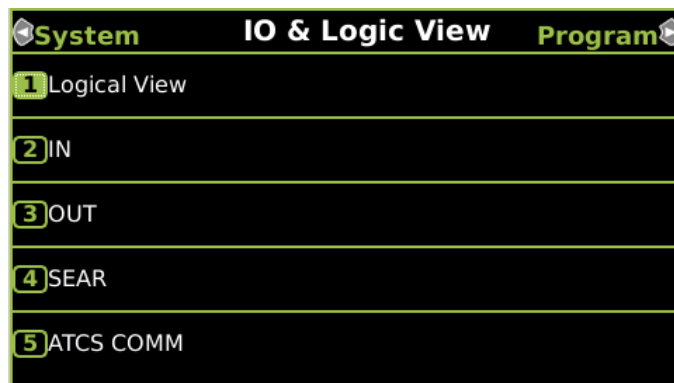

Figure 18 I/O & Logic View Menu

The following colors are used to represent the defined states:

- Green – input or output is energized
- Gray – input or output is de-energized
- Red – input or output is failed or unhealthy
- White – input or output is not configured for use by the system

Logical View

Logical View has four submenus: AND, OR, Internal States, and System States.

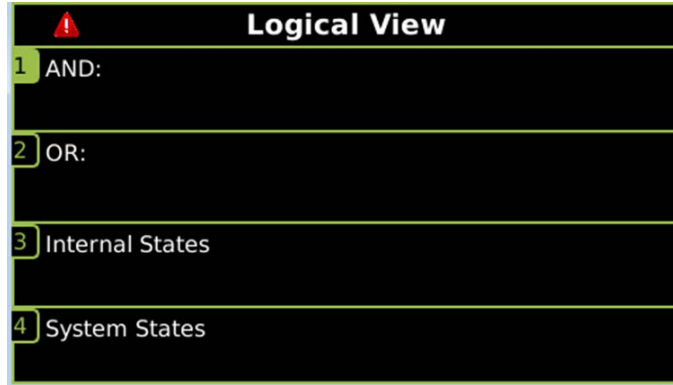

Figure 19 Logical View Menu

The Logic Detail – AND screen shows the state of the AND outputs.

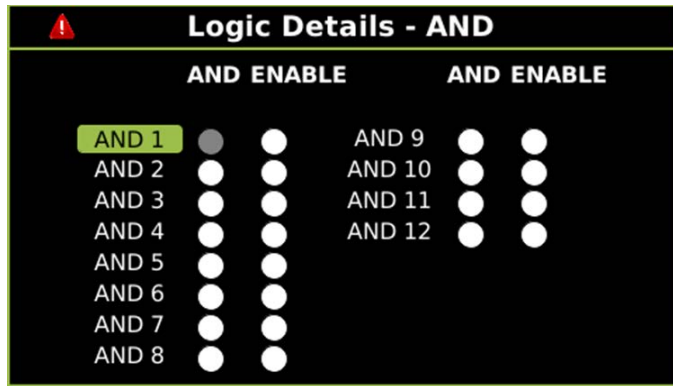

Figure 20 Logic Details - AND

Use the arrow keys on the Display module to select the AND and press **Enter**, this will bring up the logic diagram that shows what terms contribute to the selected AND output. For example, Figure 21 below shows that AND 1 is an “AND” of the T1PrimeA, T2PrimeA, and the XngTest. Red indicates that the coil or contact is de-energized, green indicates that it is energized. So, in this example AND1 is de-energized because T2PrimeA is de-energized.



Figure 21 AND Logic Example

If the name of the output in the bottom panel is shown in green, it is a selectable term. To select, press the **Enter** button and the relay diagram for this item will appear.

The **Logic Details - OR** screen shows the state of the OR outputs.

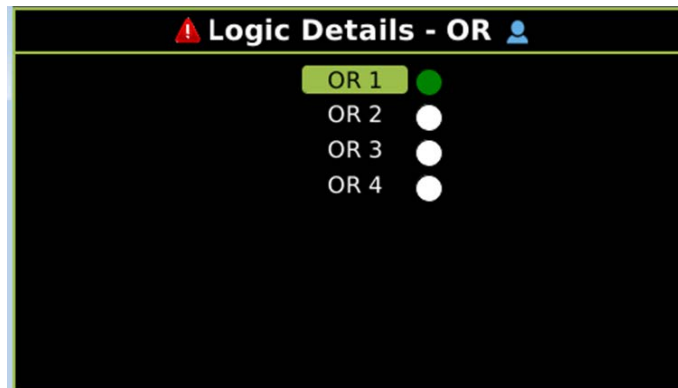

Figure 22 Logic Details - OR

Use the arrow keys to select a used OR, then press **Enter** to show the logic equation for the OR.



Figure 23 OR Logic Example

- Similar to the AND logic equation, if the terms in the window at the bottom are green, they can be selected to show their specific equations.

After it is determined that a problem is caused by a de-energized physical input, use the following procedure to isolate the cause.

Table 32: Troubleshooting Inputs

Step 1	Determine the connections to the physical inputs by referring to the circuit plans for the location. These inputs may include: <ul style="list-style-type: none"> • a DAX circuit from a remote site • a preempt health input from a traffic preempt relay • other external inputs
Step 2	If the input is connected to other equipment that is not in this bungalow, go to Step 5.
Step 3	Verify that the output of the other equipment is energized using either the indications from that equipment or a meter.
Step 4	If the output of the other equipment is energized but the GCP input is not, check the wiring between the equipment and the GCP.

Step 5	<p>Using a meter, check the remote connection input at the point it enters the bungalow.</p> <p>If the input is energized, go to the remote site and check the output.</p> <p>If the input is de-energized, check the wiring from this point through to the GCP terminals.</p>
---------------	--

WARNING

If approach length is reduced, maximum train speed must also be correspondingly reduced.

NOTE

A power up lockout is indicated by a Release Track message that appears at the end of the corresponding Track Status line. The lockout caused by the train shunt (EZ < 3) may be cleared by:

- Accessing the Alarm menu.
- Selecting the displayed message block within the affected Track Status Window.

Troubleshooting Maintenance Call (MC) Light Problems

Several operations in the Model 5000 GCP system will turn-off the MAINT CALL (MC) light. This procedure assumes:

- The warning devices are not activated and modules are healthy, including SEAR Ili and/or external SSCC IV if used. (If red warning triangles appear, proceed with Troubleshooting Flowchart, Figure 16 and Figure 17)
- No track is out-of-service
- MC operation is being placed in service for the first time and wiring must be checked.

NOTE

To ensure commonality across the Model 4000 and 5000 GCPs in the SEAR menus, the term GCP4K is used to refer to both the Model 4000 GCP and the Model 5000 GCP.

The following procedure checks the most common items first. If the MAINT CALL light does not turn on after a step, proceed to the next step.

1. Observe LED 1 on CPU module (MCF Defined LEDs, Table 35), or scroll to **IO & Logic View > 1) Logical View > 4) System States** The System States screen appears. The Maint Call is visible with a colored status indicator at the end of the line.
 - a. If LED 1 is on, or Maint Call is Green, go to Step 3.
 - b. If LED 1 is off, or Maint Call is Red, go to Step 2.
2. Refer to the circuit plans for the location and if a Maintenance Call Repeater Input is used, verify that the MC Repeater input is on. Check input LED on corresponding module, or check the IO status by:

- a. Scrolling to **Program View > 3) GCP Programming > 3) Logic Programming > 4) Logic Controls**. If the Maint Call Rpt IP Used is set to **Yes**, an input must be programmed on an input assignment screen to Maint Call Rpt IP.
 - b. Scroll to **3) GCP Programming > 6) Input/Output Assignments> 2) Input Assignments**, select the proper input and assign IN X.X Maint Call Rpt IP. The input must be energized.
3. Determine that the MC light functions by testing the lamp circuit as follows:
 - a. Measure DC voltage between B (+ meter lead) and MAINT CALL (MC) out (- meter lead) on the green connector above the CPU.
 - i. If voltage is within 0.5 volts of B, then the lamp or lamp circuit is open and must be repaired.
 - ii. If voltage is less than 1.0 volts, go to next step.
 - b. Measure between N (- meter lead) and MC (+ meter lead) on the green connector.
 - i. If voltage is within 0.5 volts of B, then the lamp circuit is okay, but the MC output is off.
 1. If LED 1 is lit, replace CPU module
 2. If LED 1 is not lit, go to the next step
 4. Battery voltage may be low:
 - a. If Low Battery Enabled is set to ON (on 1) Site Configuration screen), verify that the voltage on the CPU battery connector is more than the Low Battery Level shown.
 - b. If Low Battery Detection is set to Yes (on 8 SSCC programming, SSCC: 1 screen), verify that the voltage on the SSCC 1 battery connector is more than the Low Battery Level shown.
 - c. If Low Battery Detection is set to Yes (on 8) SSCC programming, SSCC: 2 screen), verify that the voltage on the SSCC 2 battery connector is more than the Low Battery Level shown.
 5. If a SEAR Ili is used it may monitor power off inputs (POK), external Battery Monitor or other SEAR Ili Application Program specific logic.
 - a. Temporarily turning the SEAR off may isolate the MC problem:
 - i. Scroll to Program View > 3) GCP Programming > 1) Basic Configuration > Module Selection
 - ii. Scroll down to SEAR Used **Yes***
 - iii. Select **Enter**
 - iv. When the SEAR Used screen appears, scroll down and select **No**

- b. If the MC light turns on, turn the SEAR Ili back on:
 - i. Scroll down to SEAR Used No
 - ii. Select **ENTER**
 - iii. When the SEAR Used screen appears, scroll up and select **Yes**
- 6. Refer to the circuit plans for the location and:
 - a. Verify that the SEAR Site Setup is accurate.
 - b. Verify all POK inputs are on.
 - c. If used, verify that SEAR Ili Application Program MC related parameters are correct. (Refer to the approved site drawings for required parameters)
 - d. On the Display module, scroll to IO & Logic View, then select **4) SEAR**
 - e. Scroll to the SEAR Module Status window
 - f. If GCP4K COMM STATUS is Bad, refer to the circuit plans for the location and verify the ATCS address of the Model 5000 GCP and the SEAR Ili.
 - i. If ATCS addresses are correct, replace CPU module.
 - ii. If GCP4K COMM STATUS is Good, replace the CPU module.
- 7. If the MC light stays off, turn SEAR Ili back on:
 - a. Scroll to Program View > **3) GCP Programming > 1) Basic Configuration > Module Selection**
 - b. Scroll down to SEAR Used Yes*
 - c. Select **Enter**
 - d. On the SEAR Used line, select **No**
- 8. If the MC light remains off, replace SEAR Ili.
- 9. If unit is redundant, transfer to opposite set of modules.



At crossings using MEFs xng02_00.mef and earlier, gates will begin to lower immediately (without gate delay time) when the transfer switch is used to swap between healthy units. Use caution when transferring control to avoid gates hitting vehicles or pedestrians.

- 10. If the MC lamp turns on, replace the initial CPU module.
- 11. If the MC lamp stays off, call Siemens Mobility, Inc. Technical Support.

OUT OF SERVICE FEATURE



The railroad procedures governing how to take a track circuit out of service shall be followed. The instructions in this section may be followed only if allowed by the railroad.

This section describes:

- How to take a track out of service.
- What logic functions are bypassed and the effect of that bypass on other modules and I/O
- How to place the track circuits(s) back in operation

The out of service selection has a timer option, which will restore the track back to service after the specified time. The default setting for the timer is 1 hour. The range is 1 to 23 hours.

The OUT OF SERVICE TIMEOUT: YES can be turned off by selecting **Program View > 3) GCP Programming > 1) Basic Configuration > 6) Out of Service**, then selecting **NO** for the OOS Timeout, which will take the track out of service until returned to service by the user. The OOS Settings can be viewed at **Program View > 3) GCP Programming > 1) Basic Configuration > 6) Out of Service**, which displays whether Timeout is selected, and the specified time.

Take a track Out of Service:

- Access the Out of Service Menu on the Display module by selecting the desired track in the **System View** window on the Display module. The **Track “N” Options** window opens.
- Select **6) Out Of Service** from the drop down display.

If the incorrect track is displayed, use the left and right scroll bars to navigate to the desired track.

- Select **1) GCP**. The **Track “N” Take GCP Out Of Service** window opens.
- Select **1) Take Track “N” GCP Out of Service**.
- When **Take Track “N” GCP Out of Service** is selected, the following message appears:

Are you sure you want to take GCP Out of Service.

Press Enter to Confirm and Continue

OR

Press Back to Cancel Request

- Once the GCP approach is taken out of service the **Track “N” OOS** window shows **1) GCP Out of Service**

If the Island is also to be taken out of service

- Select **2) Island**. The **Track “N” ISL Out of Service** window opens.
- Select **1) Take Track “N” ISL Out of Service**
- When **Take Track “N” ISL Out of Service** is selected, the following message appears:

Are you sure you want to take ISL Out of Service.

Press Enter to Confirm and Continue

OR

Press Back to Cancel Request

- Once the Island is taken out of service the **Track “N” OOS** window shows **2) ISL Out of Service**.

To change the OOS settings, scroll to **Program View > 3) GCP Programming > 1) Basic Configuration > 6) Out of Service**. The Out of Service window opens, depicting the following parameters:

- +OOS Control
- +OOS Timeout
- OOS Timeout
 - **+OOS Control** has the following parameters:
 - Display*
 - Display+OOS IPs
 - OOS IPs
 - 5000 Case OOS IP
 - **+OOS Timeout** turns OOS Timer off or on
 - **OOS Timeout** - The time period can be changed by selecting **OOS TIMEOUT: 1 HRS**. The NEW VALUE of 2 to 23 hours can be entered on the keypad, then press **Enter**.

NOTE

If one or more tracks are taken out of service, the Out of Service Timeout covers all tracks taken out of service with one time interval.

If the timer is running for one or more tracks out of service, and it is desired to take another track out of service for an added amount of time, do the following:

- Return all tracks to service.
- Edit the Out of Service Timeout to the new value.
- Take the tracks out of service.

The following will be displayed to indicate the final selections.

When the Track “N” OOS screen is closed by selecting the BACK button, the Display module returns to the System View window. Note that the out of service track is alternately flashing white and light blue at the end of the track row.

To return the track(s) and island(s) to service:

- Select the desired track by selecting that track number. The **Track “N” Options** window opens.
- Select **6) Out of Service**.
- Select **2) Island**. The Track :N: ISL Back in Service window opens.
- Select **1) Put Track “N” ISL Back in Service**. The Track :N: ISL Back in Service window closes.
- On the Track “N” OOS screen, **2) Island** now reads **In Service**.
- Select **1) GCP**. The Track :N: GCP Back in Service window opens.
- Select **1) Put Track “N” GCP Back in Service**. The Track :N: GCP Back in Service window closes.
- On the Track “N” OOS screen, **1) GCP** now reads In Service.
- Exit the **Track “N” OOS** window by selecting **BACK**.
- The **System View** screen appears, with the track previously OOS no longer displaying **OOS** at the end of the track row.

WARNING

Required operational tests shall be performed in accordance with railroad procedures when restoring tracks to service.

Out of Service Inputs

Sometimes it is desired to have an additional step be required to take a track out of service. When Out of Service Inputs are programmed, an input must be energized as well as the track out of service box checked for the track to be taken out of service.

WARNING

The railroad procedures for applying temporary jumpers must be followed when energizing the “Out Of Service” input(s).

To enable an OOS Input:

- Scroll to **Program View > 3) GCP Programming > 1) Basic Configuration > 6) Out of Service**. The Out of Service window opens, depicting the following parameters:
- Select **+OOS Control** by pressing **ENTER**. The **OOS Control** window opens with the following parameters:
 - Display*
 - Display+OOS IPs
 - OOS IPs
 - 5000 Case OOS IP
- Select the type input desired then select **Enter**.
- Select **BACK** until the **Main Program Menu** appears.
- Scroll to **3) GCP Programming > 6) Input/Output Assignments > 2) Input Assignments**, select the proper input and assign IN X.X Out of Service IP “N”.
- If out of service inputs are set to Yes, the proper input must be energized.

Return Track to Service

De-energizing the Out of Service Input or selecting Put ISL/GCP Back In Service returns the track to service.

NOTE

If the Transfer Module transfers while a track is out of service, the track will be returned to service and may activate the warning devices.

VERSION REPORT

To determine the software, hardware, and MCF versions, scroll to **Diags & Reports > 3) Reports & Logs > 1) Reports > 2) Version Report**. The Version Report window opens.

To view the Software Information, Select **3) Software Information**. The Software Information for Slots 1 – 9 is listed.

The Display module software versions can be viewed by navigating back using the Back button to the Version Report window. Select **5) Display Module Non-Vital CPU**. The Software Information for the Display module is listed.

The SEAR Ili software versions are determined by navigating back using the Back button to the Version Report window. Select **6) SEAR**. The Software Information for the SEAR is listed.

PROGRAMMING

The design on the circuit plans for the crossing warning system determines the programming of the 5000 GCP.

WARNING

Program changes must be performed in accordance with railroad procedures.

System operation must be verified prior to placing system in service or following programming, hardware, or wiring changes.

Templates are used to simplify 5000 GCP programming. The GCP provides several templates that represent common track circuit arrangements, including bidirectional, unidirectional, end of siding, and crossovers, including remote GCPs.

Each template:

- Provides the simplified programming menus and programming defaults for a typical track arrangement and application
- Predefines default parameters for train detection
- Has rules that specify which:
 - Track circuits are unidirectional and bidirectional
 - Track circuits have islands (indicated by an *)
 - Islands are connected to multiple track circuits
 - Track circuits are remote and DAX towards the crossing
 - Track circuits are remote and DAX away from the crossing

PROGRAMMING THE MODEL 5000 GCP

NOTE

Please refer to the Railroad Installation Drawing or the Installation Plans for the exact parameters to be entered when programming the Model 5000 GCP.

To program the Model 5000 GCP, scroll to **Program View > 3) GCP Programming...** on the Display module. The Main Program Menu Window opens.

The GCP can then be programmed by going through each individual submenu, i.e., **1) Basic configuration, 5) GCP and Island programming, 3) Logic Programming**, etc.

PASSWORDS

NOTE

Plus signs (+) that appear in the menus depict parameters that may reveal additional parameters when chosen.

The Model 5000 GCP has a two tier password system. The two types of passwords are Maintainer Passwords and Supervisor Passwords.

Supervisor Passwords are assigned to senior personnel who design the programming of the GCP. Maintainer Passwords are assigned to Field Maintainers. The Maintainer Passwords are discussed in this manual.

There are now four methods of access to the 5000 GCP's editable parameters:

- No Passwords Used:
 - When both passwords are set to **No**, anyone who gains access to the 5000 GCP can edit any parameter.
- Maintainer Password only used
 - When the Maintainer Password only is set to **Yes**, no parameters may be edited without the password, and all parameters may be edited when the Maintainer Password is entered. The default password is GCP5000.
- Supervisor Password only used
 - When the Supervisor Password only is set to **Yes**, field parameters may be edited without the password, but once the password is entered, all parameters may be edited.
- Maintainer Password and Supervisor Password both set to **Yes**.
 - When Maintainer Password and Supervisor Password are both set to **Yes**, no parameters may be edited without either password being entered: if the Maintainer Password is entered, only those parameters editable by field personnel may be edited; if the Supervisor Password is entered, all parameters may be edited.

Information regarding Supervisor Passwords and further discussion of all GCP parameters are found in Siemens Mobility, Inc. Application Guidelines for the Microprocessor Based Grade Crossing Predictor Model 5000 Family, Document Number SIG-00-08-06.

LOGIN USING THE MAINTAINER PASSWORD

Begin the login process by scrolling to **Program View > 3) GCP Programming...** on the Display module. The Enter Password Window opens.

Enter the password and select OK. The Main Program Window Opens.

ATCS INFORMATION

ATCS Communication

The ATCS communication window displays a real-time view of in and out vital messages for each vital serial communications link. Vital link sessions are shown on the face of the active CPU II+ Module as follows:

- LED #13 – Vital Link 1
- LED #14 – Vital Link 2
- LED #15 – Vital Link 3
- LED #16 – Vital Link 4

Table 33: ATCS Comms Display Acronyms

Display Acronyms	Definition
AND1 – AND4	AND functions
T1P1	Track 1 Prime
T1P2 – T1P8	Track 1 DAX A-G
T1P9	Track 1 Preempt

Connecting Echelon® LONTALK Wiring



Because the Echelon® interface is not surge protected, network connections must be restricted to the equipment contained inside a signal case or bungalow.

NOTE

For additional information concerning the Echelon® LAN, refer to Siemens Mobility, Inc. Echelon® Configuration Handbook, COM-00-07-09, Version A. If further questions persist, contact Siemens Mobility, Inc. Technical Support.

The Wayside Access Gateway is no longer required to communicate with the Model 5000 GCP. The communication functionality has been incorporated into the Model 5000 GCP hardware and software.

Vital ATCS serial protocol data may be incorporated with the LONTALK® protocol to facilitate:

- crossing control functions
- remote prediction operations via Ethernet Spread Spectrum Radio (ESSR) with the ESSR connected directly to the Model 5000 GCP case.
- vital communications with other Siemens Mobility, Inc. vital controllers

The following rules apply when using the Echelon LAN:

- Wire size is from #22 AWG to #16 AWG, stranded twisted pair.
- Each connection (node) must be wired in a daisy-chained bus configuration, no drops allowed (see Figure 25).
- The maximum wiring length of LAN bus wiring is 425 ft. (129.5 m) within a signal case or bungalow, but wiring should be kept as short as practical.

- A maximum of 8 connections (nodes) is recommended within 53 ft. (15.2 m) of cable. If necessary additional cable may be added so that no more than 8 nodes are located within any 53 ft./15.2 m length (see Figure 25).
- If additional connections are required, contact Siemens Mobility, Inc. Technical Support for assistance.
- In general, Echelon network requires a terminator for proper data transmission performance be connected at each end of the daisy chained bus configuration (see Figure 24).
- The Echelon network can be connected to ECH1 on the 5000 GCP and the Echelon terminator can be connected to ECH2 on the 5000 GCP
- Order Network Echelon Termination Unit, part number 8000-80078-001
- For further information, see Siemens Mobility, Inc. Echelon Configuration Handbook, COM-00-07-09.

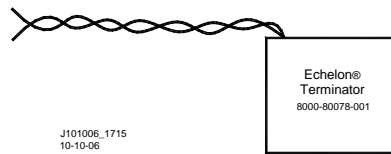
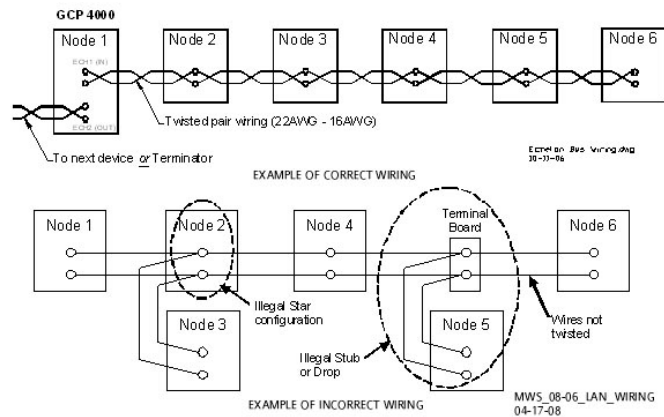

Figure 24: Siemens Echelon Terminator

Figure 25: Echelon LAN Wiring Examples



ATCS SITE ID ENTRY

Scroll to Program View and select **1) Site Configuration** to open the menu window:

- Displays the current information pertaining to this site
- Allows the current SIN to be changed
- A SIN may be changed as described in Table 34



Changing the site identification number will result in activation of warning devices. Before changing the site identification number, ensure that adequate precautions are taken to warn pedestrians, personnel, trains and vehicles in the area until proper system operation has been verified.

Table 34: Changing Site ID Number

Step 1	From Program View, select 1) Site Configuration . The Site Configuration screen opens.
Step 2	Scroll down the menu to the following parameters and enter the required values from the approved site drawing by either using the up or down arrows to scroll to the required number or by directly entering the number using the keyboard: <ul style="list-style-type: none">• On the ATCS – Railroad parameter, enter the RRR value.• On the ATCS – Line parameter, enter the LLL value.• On the ATCS – Group parameter, enter the GGG value.• On the ATCS – CPU II+ Subnode parameter, enter the SS value.
Step 3	Select the Back button until the Program View screen is displayed.
Step 4	Briefly cycle power to the power connector located above the CPU module. This can also be accomplished by cycling the Transfer Switch on redundant units. The CPU reboots. The CPU module identifies the new SIN as the current site address

UPLOAD SOFTWARE USING USB DEVICE

USB Devices are used with the A80485-1 Display module to upload software or download reports and files. The WebUI may also be used to upload software. The following actions may be performed using the USB Device:

- Installing Software Using a USB Device
- Download/Upload Configuration (PAC) Files via USB Device
- Transfer SEAR Data via USB Device

SET UP A USB DEVICE FOR USE

New software issued by Siemens Mobility, Inc. for the Model 5000 GCP is installed via the A80485-1 Display module using a USB Device.

WARNING

Uploading a new configuration, MEF, or MCF will place the GCP in a restrictive state and activate the crossing warning system.

Gates will begin to lower after gate delay passes.

Before uploading begins, take adequate precautions to warn any pedestrians, personnel, trains, and vehicles in the area until proper system operation is verified.

During module change out, software revision, reboot and calibration procedures, warning devices may not operate as intended. Take alternate means to warn vehicular traffic, pedestrians, and employees.

Tests must be performed to verify proper operation of gcp prior to placing the system back in service.

CAUTION

To minimize the time that signals are in a restrictive state, if the existing configuration needs to be saved, save it prior to selecting “upload configuration” from the USB wizard menu.

NOTE

Due to software commonality issues, the USB Display module device utilizes folders titled GCP4000 rather than GCP5000.

Follow railroad specific procedures for installing software in vital signal equipment. Companies may restrict who may install software and what additional documentation and operational checks are required.

Current software configuration requires installing a serial cable with a null modem adapter between the A80485-1 Display module’s DIAG connector and the DIAG connector on the individual modules.

When working with transferring files, the following definitions apply:

- Download – The transfer of data from GCP to USB.
- Upload – The transfer of data from USB to GCP.

Future software revisions will be issued with instructions that describe which module the software is to be loaded into. Such software instructions may supersede portions of this manual.

The following Model 5000 GCP file types can be uploaded from a USB drive connected to the Display module:

- Module Configuration Files (MCF)
- Module Executable Files (MEF)
- SEAR Ili Executable Files (BIN)
- Configuration Files (PAC)
- Control Description Language Files (CDL)

Creating the USB Device File Structure

Uploading or downloading files between the GCP and the USB Device requires that a specific file structure be created on the USB Device. The system looks for specific file folders to find or place Application, Executive, Configuration or Report files.

The file structure is as follows:

- SAFETRAN
- <DOT#>-<SITE NAME>
 - GCP4000
 - CONFIGURATIONS
 - .PAC FILES
 - REPORTS
 - <YYYY><MON>
- GCP4000
 - APPLICATIONS
 - .MCF
 - .CDL
 - EXECUTIVES
 - .MEF
 - .TGZ
 - .BIN

The types of information found in each folder is as follows (file names depicted may or may not be valid and are shown merely as examples):

- APPLICATIONS: The primary GCP Master Configuration and the SEAR CDL file:
 - GCP5K-02-3.MCF
 - 9V864_A01P.CDL (CDL may vary between railroads)
- EXECUTIVES: The executable module files:
 - VPH05_10.MEF (VLP Processor Exec)
 - NCG05_10.MEF (CP Processor Exec)
 - GCP04_70.MEF (Track Processor Exec)
 - XNG04_00.MEF (Master SW SSCC)
 - 9V816A01.C (Slave SW SSCC)
 - 9V725-A01AH.bin (SEAR Ili Exec)
 - RIO01_07.MEF (RIO Exec)
 - NG5K_MEF_1.4.66R.TGZ (Display Exec)

- CONFIGURATIONS: The GCP PAC file
 - CONFIG_679352.A-130321.PAC
- REPORTS
 - Config. Report
 - MAINT_456123A--1969Dec31 To 2013Mar21
 - system_report_21-Mar-2013.txt
 - SEAR Application Logs
 - SEAR_APP-456123A-1969Dec31 To 2013Mar21
 - CDL Logs
 - CDL_LOG2013Jun21.txt
 - SEAR Standard Logs
 - SEAR_EVT-456123A-2013Mar20 To 2013Mar21
 - SEAR System Log
 - SEAR_SYSLOG_2013Mar21.txt
 - SEAR Incident Reports
 - INC-4561323A-2031Jun21-slot0.txt
 - INC-4561323A-2031Jun21-slot1.txt
 - INC-4561323A-2031Jun21-slot2.txt
 - INC-4561323A-2031Jun21-slot3.txt
 - INC-4561323A-2031Jun21-slot4.txt
 - Status Log
 - GCPSTATUS0CP679352-2013Mar21082538.txt
 - GCPSTATUS1VLP2679352-2013Mar21091216.txt
 - GCPSTATUS2Trk679352-2013Mar21084935.txt
 - GCPSTATUS8SSCC IIII679352-2013Mar21083755.txt
 - GCPSTATUS9SSCC IIII679352-2013Mar21081425.txt
 - Summary Log
 - GCPSUMMARY0CP679352-2013Mar21082538.txt
 - GCPSUMMARY1VLP2679352-2013Mar21091216.txt
 - GCPSUMMARY2Trk679352-2013Mar21084935.txt
 - GCPSUMMARY8SSCC IIII679352-2013Mar21083755.txt
 - GCPSUMMARY9SSCC IIII679352-2013Mar21081425.txt
 - Train History
 - TrainLogAll-456123A-2013Mar21084315.txt

NOTE

The following section describes uploading and downloading software and reports from all GCP Modules except the SEAR Ili onto the USB Drive. SEAR Ili operations are described in the SEAR Ili Operation section of the manual and are found beginning on page 47.

INSTALLING SOFTWARE USING A USB DRIVE

Insert the USB drive in the USB port on the Display module to automatically open the USB menu.

A USB Detected window opens, stating USB detected. Press Back to continue or Enter for USB Menu. The USB window opens. This menu may be returned to at any time by pressing the Back button, providing the USB drive is still inserted in the port.

A – Installing Software on CPU Module

WARNING

Uploading a new configuration, MEF, or MCF will place the GCP in a restrictive state and activate the crossing warning system.

Before uploading begins, take adequate precautions to warn any pedestrians, personnel, trains, and vehicles in the area until proper system operation is verified.

Tests must be performed to verify proper operation of GCP prior to placing the system back in service.

CAUTION

To minimize the time that signals are in a restrictive state, if the existing configuration needs to be saved, save it prior to selecting “upload configuration” from the USB wizard menu.

NOTE

The examples in this section are used to explain how to install software via the Display module using USB devices. The software and version names may not be the same as seen in an actual GCP. The example will also assume the GCP is a Dual unit and the main modules are loaded first. The procedure is repeated for the standby modules.

There is no specified order when installing/updating software in the Model 5000 GCP. If replacing the CPU MEFs and the MCF as part of the same upgrade; the order of installation is immaterial. However, the MEFs must be loaded prior to attempting to place the GCP back into operation.

Installing Executive software onto the SEAR Ili is detailed in the Installing Software on SEAR II Module section found on Page 119.

Current software configuration requires installing a serial cable with a null modem adapter between the A80485-1 Display module’s DIAG connector and the USER connector on the SEAR Ili or utilizing a “nulled” DB9 cable.

In this example the following files will be loaded into the indicated modules and data port:

- CPU II+ Module
 - VLP Port – File: VPH05_10.MEF
 - DIAG (CP) Port – File: NCG05_10.MEF
 - DIAG (CP) Port – File: GCP5K-3TRK-01-0.MCF
 - CRC= 57E0DF5A

The files should be copied to the USB drive as and positioned in the file structure as depicted above.

A.1 – Replace VLP MEF

Perform the following actions:

1. Insert USB Drive in USB slot on front of Display module.
2. If Maintainer or Supervisor security has been enabled, enter the password. The password is case sensitive. If security is not enabled, proceed to Step 3.
3. Connect the serial cable between the Diag port on the Display module and the VLP port of the CPU module.
4. Select **1) Software Updates > 1) Module Updates**. The Upload to System window opens stating: **Please check the serial cable connection before uploading. Press any key to continue.**
5. Verify that the serial cable is well seated on both ends, then press any key. The Setup program begins loading.
6. Select **1) Change MEF**.
7. When asked by the Setup program to Erase the MEF?, select **1) Yes**. The Select File window opens.
8. Scroll down to select the file to be installed, in this example VPH05_10.MEF. Select Enter.
9. The new MEF begins loading. This may take a few minutes. While the file is downloading, progress will be indicated on the bottom line of the window.
10. When complete, the Display text provides all of the module update options. Select **0) Exit Setup**. The Upload to System window opens and states: Exit software finished rebooting the module.
11. Press the Back button. Select **0) Exit View**.

A.2 – Replace CPU MEF

Perform the following actions:

1. Insert USB Drive in USB slot on front of the Display module.
2. If Maintainer or Supervisor security has been enabled, enter the password. The password is case sensitive. If security is not enabled, proceed to Step 3.
3. Connect the serial cable between the Diag port on the Display module and the DIAG (CP) port of the CPU module.
4. Select **1) Software Updates > 1) Module Updates**. The Upload to System window opens stating: Please check the serial cable connection before uploading. Press any key to continue.

5. Verify that the serial cable is well seated on both ends, then press any key. The Setup program begins loading.
6. Select **3) Change MEF**.
7. When asked by the Setup program to Erase the MEF?, select **1) Yes**. The Select File window opens.
8. Scroll down to select the file to be installed, in this example NCG05_10.MEF. Select Enter.
9. The new MEF begins loading. This may take a few minutes. While the file is downloading, progress will be indicated on the bottom line of the window.
10. When complete, the Display text provides all of the module update options. Select **0) Exit Setup**. The Upload to System window opens and states: Exit software finished rebooting the module.
11. Press the Back button. Select **0) Exit View**.

A.3 - Change the MCF.

Perform the following actions:

1. Insert USB Drive in USB slot on front of the Display module.
2. If Maintainer or Supervisor security has been enabled, enter the password. The password is case sensitive. If security is not enabled, proceed to Step 3.
3. Connect the serial cable between the Diag port on the Display module and the DIAG (CP) port of the CPU module.
4. Select **1) Software Updates > 1) Module Updates**. The Upload to System window opens stating: Please check the serial cable connection before uploading. Press any key to continue.
5. Verify that the serial cable is well seated on both ends, then press any key. The Setup program begins loading.
6. Select **2) Change MCF**.
7. When asked by the Setup program to Erase the MCF Flash?, select **1) Yes**. The Select File window opens.
8. Scroll down to select the file to be installed, in this example GCP-T6X-02-F.MCF. Select Enter.
9. The new MCF begins loading. This may take a few minutes. While the file is downloading, progress will be indicated on the bottom line of the window.

NOTE

After the progress bar reaches 100% and stops, the CPU loads a copy of the file to the ECD on the chassis. This will be indicated on the Display module screen by the field turning to a grey background and on the 4-character display on the CPU as copying MCF to ECD. Wait until this process completes and the text field has a black background before proceeding.

A.4 – Change the MCFCRC

1. Select **1) Change MFCRC**.
2. The **Enter MCF CRC for GCP** window opens.
3. Use the Back arrow to clear the number that appears in the window, and use the keypad to enter the CRC issued with the software revision instructions. The CRC will always be 8 characters consisting of 0 through 9 and A through F. Once the number has been entered and verified correct, select Enter.
4. When complete, the Display text provides all of the module update options. Select **0) Exit Setup**. The Upload to System window opens and states: **Exit software finished rebooting the module**.
5. Press the Back button. Select **0) Exit View**.

This completes Installing Software on the CPU Card.

B – Installing Software on CPU III Module

⚠ WARNING

Uploading a new configuration, MEF, or MCF will place the GCP in a restrictive state and activate the crossing warning system.

Before uploading begins, take adequate precautions to warn any pedestrians, personnel, trains, and vehicles in the area until proper system operation is verified.

Tests must be performed to verify proper operation of GCP prior to placing the system back in service.

⚠ CAUTION

To minimize the time that the crossing is active, if the existing configuration needs to be saved, save it prior to selecting “upload configuration” from the USB wizard menu.

NOTE

The examples in this section are used to explain how to install software via a USB and Ethernet cable connecting the Display module to the CPU III or via the WebUI using an Ethernet cable to connect directly to the CPU III. The software and version names may not be the same as seen in an actual GCP. The example will also assume the GCP is a Dual unit and the main modules are loaded first. The procedure is repeated for the standby modules.

There is no specified order when installing/updating software in the Model 5000 GCP. If replacing the CPU MEFs and the MCF as part of the same upgrade; the order of installation is immaterial; however, the MEFs must be loaded prior to attempting to place the GCP back into operation.

In this example, the following files will be loaded into the indicated modules:

- CPU III Module
 - DIAG (CP) File: GCPNCP3_MEF_1.1.32r.tgz (CPU III CP executive software begins with GCP)
 - VLP File: 9VC72-V3H00_03.mef
 - VLP MCF: – File: gcp5k-02-3.mcf, CRC=0EA1F809
- The files should be copied to the GCP4000/Executive folder of the USB drive if a USB drive is being used instead of the WebUI.

B.1 – Replace CP MEF on CPU III via USB Drive

Perform the following actions:

1. Insert USB Drive in USB slot on front of the Display module.
2. If Maintainer security has been enabled, enter the password. The password is case sensitive. If security is not enabled, proceed to Step 3.
3. Connect the Ethernet cable between the Laptop port on the Display module and the Laptop port of the CPU III module.
4. You will need to verify that the Display module is set up as a Client instead of a Server, to do so, access the **Laptop Ethernet Port menu Program View > 3) Display Settings > Laptop Ethernet Port**.
5. Select **Client** if Display module is configured as Server.
6. From the USB menu, select **3) Software Updates > 3) CPU-III Update**
7. Install an Ethernet cable from the Laptop port on the Display module to the Laptop port on the CPU III unit. Verify that the Ethernet cable is well seated on both ends, then press any key.
8. Select **1) Change CP MEF**.
9. When asked by the Setup program to Erase the MEF, select **1) Yes**.
10. The **Select File** window opens.
11. Scroll down to select the file to be installed, in this example: gcpNcp3_mef_1.1.32r.tgz. Press **Enter**.
12. The new MEF begins loading. This may take a few minutes. While the file is uploading, progress will be indicated on the bottom line of the window.
13. When complete, the Display text provides all of the module update options. If a new MCF needs loading, go to Step 6 in the next section, otherwise select **0) Exit Setup**.
14. The **Upload to System** window opens and states: **Exit software finished rebooting the module**.
15. Press the Back button. The USB SW Updates menu is shown (as per Step 6).

B.2 –Replace CP MEF on CPU III via WebUI

1. Connect Ethernet cable from laptop to Laptop port on the front of the CPU III unit
2. Locate the IP address of the GCP 5000 unit via the selector buttons on the front of the CPU III unit. Type into a compatible web browser with https:// in front of it. The web browser will warn that the connection is not private. Select **Advanced** then **Proceed to <IP Address>**.

3. Log into the WebUI using the appropriate User Name and Password.
4. From the menu bar above, select **Software Updates**, then from the menu on the left, select **CP MEF**, then click **Unlock**.
5. Confirm user presence with button on the front of the CPU module, click **OK** on the pop-up window, then, select **Browse** to locate the desired file.
6. Once the correct file is selected, click the **Update** button (located next to the **Unlock** button).
7. The uploading status will show until complete. Once complete the message **MEF file uploaded successfully** will display.

B.3 –Replace VLP MEF on CPU III via USB drive

Perform the following actions:

1. Insert USB Drive in USB slot on front of the Display module.
2. If Maintainer security has been enabled, enter the password. The password is case sensitive. If security is not enabled, proceed to Step 3.
3. Connect an Ethernet cable between the Laptop port on the Display module and the Laptop port of the CPU III module.
4. You will need to verify that the Display module is set up as a Client instead of a Server, to do so, access the **Laptop Ethernet Port menu Program View > 3) Display Settings > Laptop Ethernet Port**.
5. Select **Client** if Display module is configured as Server.
6. From the USB menu Select **1) Software Updates > 3) CPU-III Update**.
7. Verify that the Ethernet cable is well seated on both ends.
8. Select **2) Update VLP MEF**.
9. When asked by the Setup program to Erase the MEF, select **1) Yes**.
10. The **Select File** window opens.
11. Scroll down to select the file to be installed, in this example 9VC72-V3H00_03.mef. Select **Enter**.
12. The new MEF begins loading. This may take a few minutes. While the file is uploading, progress will be indicated on the bottom line of the window.
13. When complete, the Display text provides all of the module update options. Select **0) Exit Setup**.
14. The Upload to System window opens and states: **Exit software finished rebooting the module**.
15. Press the **Back** button.

B.4 – Replace VLP MEF on CPU III via WebUI

1. Locate the IP address of the GCP 5000 unit via the selector buttons on the front of the CPU III unit. Type into a compatible web browser with https:// in front of it. The web browser will warn that the connection is not private. Select **Advanced** then **Proceed to <IP Address>**.
2. Login to the WebUI using the appropriate User Name and Password.
3. From the menu on the left, select **VLP**, then click **Unlock**.

4. Confirm user presence with button on the front of the CPU III module, click **OK**, then select **Browse** and locate the desired file.
5. Click the **Update** button located next to the **Unlock** button.
6. The uploading status will show until complete. Once complete, the message **MEF file uploaded successfully** will display.

B.5 – Change the MCF on CPU III via USB

Perform the following actions:

1. Insert USB Drive in USB slot on front of the Display module.
2. If Maintainer security has been enabled, enter the password. The password is case sensitive. If security is not enabled, proceed to Step 3.
3. Connect an Ethernet cable between the Laptop port on the Display module and the Laptop port of the CPU III module.
4. You will need to verify that the Display module is set up as a Client instead of a Server, to do so, access the **Laptop Ethernet Port menu Program View > 3) Display Settings > Laptop Ethernet Port**.
5. Select **Client** if Display module is configured as Server.
6. From the USB menu Select **1) Software Updates > 3) CPU-III Update**.
7. Verify that the Ethernet cable is well seated on both ends.
8. Select **3) Update MCF**.
9. When asked by the Setup program to Erase the MCF Flash, select **1) Yes**.
10. The **Select File** window opens.
11. Scroll down to select the file to be installed, in this example gcp5k-trc-02-3.mcf. Select **Enter**.
12. The new MCF begins loading. This may take a few minutes. While the file is downloading, progress will be indicated on the bottom line of the window.

NOTE

After the progress bar reaches 100% and stops, the CPU loads a copy of the file to the ECD on the chassis. This will be indicated on the Display screen by the field turning to a grey background and on the 4-character display on the CPU as Downloading MCF then Copying MCF TO ECD. Wait until this process completes and the text field has a black background before proceeding, 4-character display shows Setup.

B.6 – Change the MCFCRC

1. Select **1) Change MFCRC**.
2. The **Enter MCF CRC for GCP** window opens.
3. Use the back arrow to clear the number that appears in the window, then use the keypad to enter the CRC issued with the software revision instructions. The CRC will always be 8 characters consisting of 0 through 9 and A through F. Once the number has been entered and verified correct, select **Enter**.
4. When complete, the Display text provides all of the module update options. Select **0) Exit Setup**. The **Upload to System** window opens and states: Exit software finished rebooting the module.
5. Press the Back button. Select **0) Exit View**.

B.7 – Change the MCF on CPU III via WebUI

1. Locate the IP address of the GCP 5000 unit via the selector buttons on the front of the CPU III unit. Type into a compatible web browser with https:// in front of it. The web browser will warn that the connection is not private. Select **Advanced** then **Proceed to <IP Address>**.
2. Login to the WebUI using the appropriate User Name and Password.
3. From the menu on the left, select **VLP MCF**, then click **Unlock**.
4. Click the **Browse** button and select the correct file. (Note the MFCRC for entry into the **Enter MFCRC** field as well).
5. Select the **Update** button. Once the file has finished loading the message **MFCRC uploaded successfully and MCF file uploaded successfully**.

This completes **Installing Software on the CPU Card**.

C – Installing Software on Track Module

To install the gcp04_70.mef files on the Track Modules.

- Track Module
 - DIAG Port – File: gcp04_70.mef

Perform the following actions:

1. Insert USB Drive in USB slot on front of Display module
2. If Maintainer or Supervisor security has been enabled, enter the password. The password is case sensitive. If security is not enabled, proceed to Step 3.
3. Connect the serial cable between the Diag port on the Display module and the DIAG (CP) port of the Track module to be updated.
4. Select **1) Software Updates > 1) Module Updates**. The Upload to System window opens stating: Please check the serial cable connection before uploading. Press any key to continue.
5. Verify that the serial cable is well seated on both ends, then press any key. The Setup program begins loading.
6. Select **1) Change MEF**.

7. When asked by the Setup program to Erase the MEF?, select **1) Yes**. The Select File window opens.
8. Scroll down to select the file to be installed, in this example gcp04_70.mef. Select Enter.
9. The new MEF begins loading. This may take a few minutes. While the file is downloading, progress will be indicated on the bottom line of the window.
10. When complete, the Display text provides all of the module update options. Select **0) Exit Setup**. The Upload to System window opens and states: Exit software finished rebooting the module.
11. Press the Back button. Select **0) Exit View**.
12. Repeat the procedure for the remaining Track Modules in the MAIN section of the GCP.

D – Installing Software on RIO Module

To install the RIO01_07.MEF files on the Track Modules.

- RIO Module
 - DIAG Port – File: RIO01_07.MEF

Perform the following actions:

1. Insert USB Drive in USB slot on front of Display module
 2. If Maintainer or Supervisor security has been enabled, enter the password. The password is case sensitive. If security is not enabled, proceed to Step 3.
 3. Connect the serial cable between the Diag port on the Display module and the DIAG (CP) port of the RIO module to be updated.
 4. Select **1) Software Updates > 1) Module Updates**. The Upload to System window opens stating: Please check the serial cable connection before uploading. Press any key to continue.
 5. Verify that the serial cable is well seated on both ends, then press any key. The Setup program begins loading.
 6. Select **1) Change MEF**.
 7. When asked by the Setup program to Erase the MEF?, select **1) Yes**. The Select File window opens.
 8. Scroll down to select the file to be installed, in this example RIO01_07.MEF. Select Enter.
 9. The new MEF begins loading. This may take a few minutes. While the file is downloading, progress will be indicated on the bottom line of the window.
 10. When complete, the Display text provides all of the module update options. Select **0) Exit Setup**. The Upload to System window opens and states: Exit software finished rebooting the module.
 11. Press the Back button. Select **0) Exit View**.
 12. Repeat the procedure for the remaining RIO Modules in the MAIN section of the GCP.
- Repeat the above procedures for installing all files on the STANDBY modules.

E – Installing Software on SSCC Illi Module

If the instructions issued with the software revision call for upgrading the software in the SSCC Illi Module, the next step is to install the specified MEF file on the SSCC modules.

The SSCC Modules have a master processor that controls slave processors, which control the independent lamp outputs. Therefore, there are separate MEFs for the master and slave processors.

- SSCC Illi Module
 - DIAG Port – Master File: Xng04_00.mef
 - DIAG Port – Slave File: 9V816A01.C

NOTE

Selecting **1) Change App Code** will change Application Code, which on the SSCC are MEF files. When loading software for Master/Slave operations, “Master” loads the MEF on the Master processor and “All Slaves” loads the MEF on the slave processors. Currently, slave software must be installed using the Diagnostic Terminal (DT). Refer to Model 5000 GCP Field Manual, Ver. C2, SIG-00-08-10, Ver. C2, page 130 for the procedures to load SSCC Illi slave software using the DT software.

Perform the following actions:

1. Insert USB Drive in USB slot on front of the Display module.
2. If Maintainer or Supervisor security has been enabled, enter the password. The password is case sensitive. If security is not enabled, proceed to Step 3.
3. Connect the serial cable between the Diag port on the Display module and the DIAG (CP) port of the CPU module.
4. Select **1) Software Updates > 1) Module Updates**. The Upload to System window opens stating: Please check the serial cable connection before uploading. Press any key to continue.
5. Verify that the serial cable is well seated on both ends, then press any key. The Setup program begins loading.
6. Select **1) Change App Code**.
7. Select **1) Change Master**.
8. Scroll down to select the file to be installed, in this example XNG04_00.MEF. Select Enter.
9. The new MEF begins loading. This may take a few minutes. While the file is downloading, progress will be indicated on the bottom line of the window.
10. When complete, the Display text provides all of the module update options. Select **0) Exit Setup**. The Upload to System window opens and states: Exit software finished rebooting the module.
11. Press the Back button. Select **0) Exit View**.
12. Connect the serial cable to the second SSCC Illi unit and repeat Steps 1 – 13 above.



When loading software into slave processors, the light on the loading processor will not flash, but the light on the other processor will.

Refer to the NOTE above to load slave software.

F – Installing Software on Display Module

To install the Non-Vital MEF files on the A80485-1 Display module.

- Display Module
 - USB Port – File: ng5k_initfs_1.4.66r.tar.gz

Perform the following actions:

1. Insert USB Drive in USB slot on front of the Display module.
2. If Maintainer or Supervisor security has been enabled, enter the password. The password is case sensitive. If security is not enabled, proceed to Step 3.
3. Select **1) Software Updates > 2) Display Executive Update**.
 - The Select File window opens. Select the correct file to load, in this example ng5k_initfs_1.4.66r.tar.gz. Select Enter.
4. The Upload NV Executive window opens, stating: Please wait. Request sent to Executive... The new MEF begins loading. This may take a few minutes. While the file is downloading, progress will be indicated on the bottom line of the window.
5. When complete, the Upload to NV Executive window opens and states: Uploaded NV Executive. Press Enter to Reboot OR Back to Reboot later.
6. Select Enter. The Display module reboots.
7. Press the Back button. Select **0) Exit View**.

G – Transfer Card, A80406 or A80468.

The Transfer Card software is not field upgradable and software changes are performed at the factory.

DOWNLOAD/UPLOAD CONFIGURATION (PAC) FILES VIA USB DEVICE

A – Download Configuration File To USB Drive

Perform the following actions:

1. Insert USB Drive in USB slot on front of the Display module.
2. If Maintainer or Supervisor security has been enabled, enter the password. The password is case sensitive. If security is not enabled, proceed to Step 3.
3. Select 3) Download Configuration. The Download configuration window opens, stating: Downloading PAC File....Please do not Remove USB
4. When the file has downloaded from the Display module to the USB Drive, the PAC File Download window opens, stating: Download Completed. File is saved at (the actual file location on the USB Drive). Press any key to continue.



Uploading a new configuration, MEF, or MCF will place the GCP in a restrictive state and activate the crossing warning system.

Before uploading begins, take adequate precautions to warn any pedestrians, personnel, trains, and vehicles in the area until proper system operation is verified.

Tests must be performed to verify proper operation of gcp prior to placing the system back in service.



To minimize the time that signals are in a restrictive state, if the existing configuration needs to be saved, save it prior to selecting “upload configuration” from the USB wizard menu.

B – Upload Configuration File To GCP

Perform the following actions:

1. Insert USB Drive in USB slot on front of the Display module.
2. If Maintainer or Supervisor security has been enabled, enter the password. The password is case sensitive. If security is not enabled, proceed to Step 3.
3. Select 4) **Upload Configuration**. The Unlock Warning window opens, stating: Upload configuration will place the GCP in a restrictive state and activate the crossing warning system. Do you want to continue? Enter to continue Or Press Back to cancel request.

NOTE

CDL files are typically included with an externally produced PAC file and would only require loading if the file needed to be changed.

NOTE

Selecting the **Back** button on the Save Configuration window skips saving the current configuration, but does continue with the process of uploading the new configuration.

4. The Save Configuration window opens, stating: Do you want to save current configuration? Press **Back** to cancel request Or **Enter** to continue.
5. Select **Enter**. The Download configuration window opens, stating: Downloading PAC File....Please do not Remove USB. This may take a few minutes. While the file is downloading, progress will be indicated on the bottom line of the window.
6. When the file has downloaded from the Display module to the USB Drive, the PAC File Download window opens, stating: Download Completed. File is saved at (the actual file location on the USB Drive). Press any key to continue.
7. The Select File window opens. Scroll down to select the correct PAC file. Select **Enter**. The Upload Configuration window opens, stating "Saving configuration."
8. The Save window opens, stating: Press the SEL or NAV button and then select Enter to save parameters. The File name, Site Name, SIN, and CCN data then appear, followed by: "Do you want to save the parameters?" Press the SEL or NAV buttons on the CPU Card and then select **Enter**.
9. The Upload configuration window opens, stating: System will now reboot to load the new settings. Press Any Key to Continue.

C – Checking CCN and OCCN

After uploading a new Configuration (PAC file), check the CCN and OCCN via the Program View screen.

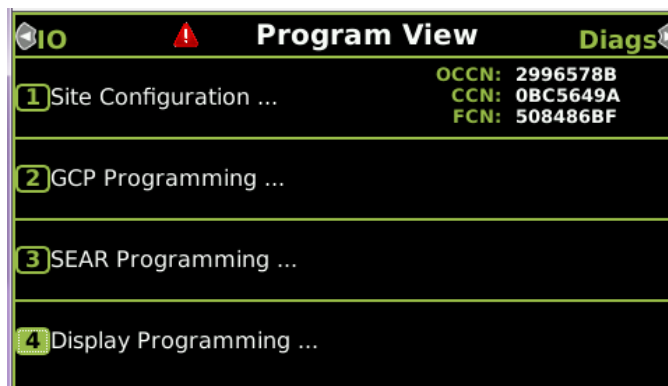

Figure 26 Program View and Check Numbers

DOWNLOADING REPORTS AND LOGS

A USB Detected window opens, stating USB detected. Insert the USB drive in the USB port on the Display module to automatically open the USB window. If Maintainer or Supervisor security has been enabled, enter the password. The password is case sensitive. If security is not enabled, proceed normally. Press Back to continue or Enter for USB Menu. The USB window opens. This menu may be returned to at any time by pressing the Back button, providing the USB drive is still inserted in the port.

A – Download Configuration Report

To download the Configuration Report to the USB drive:

1. From the USB menu, select **2) Download Configuration Report**, The USB window states the operation Retrieve Configuration Rpt with the Status In Progress. The message Saving Data, Do Not Remove USB appears across the bottom of the window.
2. When the report has downloaded, the Status message changes to Complete.
3. Select Back to return to the USB menu.

B – Download GCP Logs

Select **5) Download GCP Logs** to download one of the GCP Logs:

- Status Log
- Summary Log
- Maintenance Log

B.1 – Download Status Log

1. Select **1) Download Status Log**. The Select Card window opens displaying the list of all active Cards:
 - Slot 1 – CP
 - Slot 1 – VLP2
 - Slots 2 through 7 – Track or RIO
 - Slot 8 – SSCC IIIi
 - Slot 9 – SSCC IIIi
2. Scroll down to select the desired card for the Status Log. The Download GCP Status Log window opens, stating Downloading GCP Status Logs.... Please do not remove USB. No. of Events NNN>
3. When complete, the window states Download completed. File saved at (entire path and file name provided). Press any key to Continue.
4. Press any key. The menu returns to depict the Status, Summary, and Maintenance Log choices.

B.2 – Download Summary Log

1. Select **2) Download Summary Log**. The Select Card window opens displaying the list of all active Cards:
 - Slot 1 – CP
 - Slot 1 – VLP2
 - Slot s 2 through 7 – Track or RIO
 - Slot 8 – SSCC IIIi
 - Slot 9 – SSCC IIIi

2. Scroll down to select the desired card for the Status Log. The Download GCP Log window opens, stating Downloading GCP Summary Logs.... Please do not remove USB. No. of Events NNN>
3. When complete, the window states Download completed. File saved at (entire path and file name provided). Press any key to Continue.
4. Press any key. The menu returns to depict the Status, Summary, and Maintenance Log choices.

B.3 – Download Maintenance Log

1. Select **3) Download Maintenance Log**.
2. The USB window states the operation Download Maintenance Log with the Status In Progress. The message Saving Data, Do Not Remove USB appears across the bottom of the window.
3. When the report has downloaded, the Status message changes to Complete.
4. Select Back to return to the USB menu.

C – Download Train History

1. Select **6) Download Train History**.
2. The Download GCP Train History window opens, stating Downloading GCP Status Logs.... Please do not remove USB. No. of Events NNN>
3. When complete, the window states Download completed. File saved at (entire path and file name provided). Press any key to Continue.

TRANSFER SEAR DATA VIA USB DEVICE

NOTE

Current software configuration requires installing a serial cable with a null modem adapter between the A80485-1 Display module's DIAG connector and the USER connector on the SEAR Ili if software is being installed on the SEAR Ili module.

A – Installing Software on SEAR Ili Module

Per the instructions issued with the software revision, the next step is to install the s2i_exec_5k_F3.bin files on the SEAR Ili Module.

- USER Port – Master File: s2i_exec_5k_F3.bin

Perform the following actions:

1. Insert USB Drive in USB slot on front of the Display module
2. If Maintainer or Supervisor security has been enabled, enter the password. The password is case sensitive. If security is not enabled, proceed to Step 3.
3. Select **8) SEAR Transfers > 1) Upload Executive**. The Select File window listing the possible software files of type .BIN.
4. Scroll down to select the file to be installed, in this example s2i_exec_5k_F3.bin.
5. The Upload Executive window opens, stating: Please wait. Request sent to Executive... The new .BIN file begins loading. This may take a few minutes. While the file is downloading, progress will be indicated on the bottom line of the window.
6. When complete, the Upload to System window opens and states: Successful. Press any key to Exit USB Menu Screen.
7. Reprogram SEAR per the site plan to return the SEAR to fully operational state.

B – CDL File Operations

Perform the following actions:

1. Insert USB Drive in USB slot on front of the Display module.
2. If Maintainer or Supervisor security has been enabled, enter the password. The password is case sensitive. If security is not enabled, proceed to Step 3.
3. Select **8) SEAR Transfers > 2) Upload CDL**. The Select File window listing the possible software files of type .CDL.
4. Scroll down to select the file to be installed, in this example 9V864-A01P.CDL.
5. The Upload Executive window opens, stating: Please wait. Request sent to Executive... The new CDL begins loading. This may take a few minutes. While the file is downloading, progress will be indicated on the bottom line of the window.
6. When complete, the Upload to System window opens and states: Successful. Press any key to Exit USB Menu Screen.
7. Reprogram SEAR per the site plan to return the SEAR to fully operational state.

C – Download SEAR Logs and Reports

There are multiple SEAR Logs available for download:

- **Download CDL Log** (Information, warnings, and errors detected while compiling the CDL program)
- **Download Application Log** (Log entries created by CDL program during operation)
- **Download Standard Log** (All recorded event entries for the location)
- **Download System Log** (Information on the internal operation of the SEAR)
- **Download Incident Report** (A segment of the standard log stored in flash memory)

C.1 – Download CDL Log

1. Insert USB Drive in USB slot on front of the Display module.
2. If Maintainer or Supervisor security has been enabled, enter the password. The password is case sensitive. If security is not enabled, proceed to Step 3.
3. Select **8) SEAR Transfers > 4) Download CDL Log**. The Download CDL Log screen opens, and states In Progress. The In Progress changes to Complete when the download is complete. The file is saved as CDL_LOG_YYYYMONDD-N.TXT.
4. Select BACK twice.

C.2 – Download Application Log

There are four types of Application Log available for download:

- Capture Last 24 Hours of Application Logs
- Capture Last 2 Weeks of Application Logs
- Capture All Application Logs
- Capture Application Logs by Date & Time

Capture Last 24 Hours of Application Logs

1. Insert USB Drive in USB slot on front of Display module
2. If Maintainer or Supervisor security has been enabled, enter the password. The password is case sensitive. If security is not enabled, proceed to Step 3.
3. Select **8) SEAR Transfers > 5) Download Application Log > 1) Capture Last 24 Hours of Application Logs**. The Retrieve 24 Hr App Logs screen opens, and states In Progress. The In Progress changes to Complete when the download is complete. The file is saved as SEAR_APP_YYYYMONDD TO YYYYMONDD.TXT
4. Select BACK three times.

Capture Last 2 Weeks of Application Logs

1. Insert USB Drive in USB slot on front of the Display module.
2. If Maintainer or Supervisor security has been enabled, enter the password. The password is case sensitive. If security is not enabled, proceed to Step 3.

3. Select **8) SEAR Transfers > 5) Download Application Log > 2) Capture Last 2 Weeks of Application Logs**. The Retrieve 2 Week App Logs screen opens, and states In Progress. The In Progress changes to Complete when the download is complete. The file is saved as SEAR_APP_YYYYMONDD TO YYYYMONDD.TXT
4. Select **Back** three times.

Capture All Application Logs

1. Insert USB Drive in USB slot on front of the Display module.
2. If Maintainer or Supervisor security has been enabled, enter the password. The password is case sensitive. If security is not enabled, proceed to Step 3.
3. Select **8) SEAR Transfers > 5) Download Application Log > 2) Capture All Application Logs**. The Retrieve All App Logs screen opens, and states In Progress. The In Progress changes to Complete when the download is complete. The file is saved as SEAR_APP_1969Dec31 To YYYYMONDD.TXT
4. Select **BACK** three times.

Capture Application Logs By Date & Time

1. Insert USB Drive in USB slot on front of the Display module.
2. If Maintainer or Supervisor security has been enabled, enter the password. The password is case sensitive. If security is not enabled, proceed to Step 3.
3. Select **8) SEAR Transfers > 5) Download Application Log > 2) Capture All Application Logs**. The Application Log Filter screen opens
4. Scroll using the arrows to select the Start Date, Start Time, End Date, & End Time of the Application Log to be captured. Scroll to Download. Select Download.
5. The Retrieve Date/Time App Logs screen opens and states In Progress. The In Progress changes to Complete when the download is complete. The file is saved as SEAR_APP_YYYYMONDD TO YYYYMONDD.TXT
6. Select **BACK** three times.

C.3 – Download Standard Log

There are four types of Standard Log available for download:

- Capture Last 24 Hours of Standard Logs
- Capture Last 2 Weeks of Standard Logs
- Capture All Standard Logs
- Capture Standard Logs by Date & Time

Capture Last 24 Hours of Standard Logs

1. Insert USB Drive in USB slot on front of the Display module.

2. If Maintainer or Supervisor security has been enabled, enter the password. The password is case sensitive. If security is not enabled, proceed to Step 3.
3. Select **8) SEAR Transfers > 5) Download Standard Log > 1) Capture Last 24 Hours of Standard Logs**. The Retrieve 24 Hr Std Logs screen opens, and states In Progress. The In Progress changes to Complete when the download is complete. The file is saved as SEAR_EVT_YYYYMONDD TO YYYYMONDD.TXT
4. Select BACK three times.

Capture Last 2 Weeks of Standard Logs

1. Insert USB Drive in USB slot on front of the Display module.
2. If Maintainer or Supervisor security has been enabled, enter the password. The password is case sensitive. If security is not enabled, proceed to Step 3.
3. Select **8) SEAR Transfers > 5) Download Standard Log > 2) Capture Last 2 Weeks of Standard Logs**. The Retrieve 2 Week Std Logs screen opens, and states In Progress. The In Progress changes to Complete when the download is complete. The file is saved as SEAR_EVT_YYYYMONDD TO YYYYMONDD.TXT
4. Select BACK three times.

Capture All Standard Logs

1. Insert USB Drive in USB slot on front of the Display module.
2. If Maintainer or Supervisor security has been enabled, enter the password. The password is case sensitive. If security is not enabled, proceed to Step 3.
3. Select **8) SEAR Transfers > 5) Download Standard Log > 2) Capture All Standard Logs**. The Retrieve All Std Logs screen opens, and states In Progress. The In Progress changes to Complete when the download is complete. The file is saved as SEAR_APP_1969Dec31 To YYYYMONDD.TXT
4. Select BACK three times.

Capture Standard Logs By Date & Time

1. Insert USB Drive in USB slot on front of the Display module.
2. If Maintainer or Supervisor security has been enabled, enter the password. The password is case sensitive. If security is not enabled, proceed to Step 3.
3. Select **8) SEAR Transfers > 6) Download Standard Log > 2) Capture All Standard Logs**. The Standard Log Filter screen opens
4. Scroll using the arrows to select the Start Date, Start Time, End Date, & End Time of the Standard Log to be captured. Scroll to Download. Select Download.

5. The Retrieve Date/Time App Logs screen opens and states In Progress. The In Progress changes to Complete when the download is complete. The file is saved as SEAR_EVT_YYYYMONDD TO YYYYMONDD.TXT
6. Select BACK three times.

C.4 – Download System Log

1. Insert USB Drive in USB slot on front of the Display module.
2. If Maintainer or Supervisor security has been enabled, enter the password. The password is case sensitive. If security is not enabled, proceed to Step 3.
3. Select **8) SEAR Transfers > 7) Download System Log**. The Download System Log screen opens, and states In Progress. The In Progress changes to Complete when the download is complete. The file is saved as SEAR_SYSLOG_YYYYMONDD-N.TXT.
4. Select BACK twice.

C.5 – Download Incident Report(s)

1. Insert USB Drive in USB slot on front of the Display module.
2. If Maintainer or Supervisor security has been enabled, enter the password. The password is case sensitive. If security is not enabled, proceed to Step 3.
3. Select **8) SEAR Transfers > 8) Download Incident Report(s)**. The Download Incident Report(s) screen opens, and states In Progress. The In Progress changes to Complete when the download is complete. The files are saved as INC_456123A_YYYYMONDD-slot0.TXT
INC_456123A_YYYYMONDD-slot1.TXT, etc.
4. Select BACK twice.

D – EZ And EX Value Utilization

The A80485-1 Display module may recording and download EZ and EX history data. Unlike the A80407-3 Display module, EZ and EX record data may be recorded without the presence of a USB Drive.

D.1 – Real Time Recording of EZ And EX Values

1. Scroll to the Program View menu and select **1) Display Programming > 2) Log Setup**. The Disp Log Setup window opens.
2. Scroll down to the EZ/EX Recording parameter and select Enter. The EZ/EX Recording window opens.
3. Scroll down to Enabled, select Enter.
4. The EZ and EX data is stored for 7 days, so when downloaded there will be 7 separate zipped files, one for each day.

D.2 – Using Recorded EZ & EX Files

The recorded values are stored in a .csv file that can be reviewed and graphed in Microsoft® Excel®.

1. To view .csv files, open Microsoft Excel.
2. Select File \Open.
3. On the Open window, select 'Text files (*.prn; *.txt; *.csv)' in the Files of type: field.
4. Type of select the file name to be viewed.
5. Press **Open**.

The file data appears in columns similar to the figure below.

	A	B	C	D	E	F	G	H
1	Count	DateTime	T1 Ez	T1 CheckE	T1 Ex	T1 Isl Occ	T1 Prime	AND1 XR
2	0	#####	99	99	93	125	140	155
3	1	#####	99	99	93	125	140	155
4	2	#####	99	99	93	125	140	155
5	3	#####	99	100	93	125	140	155
6	4	#####	100	99	93	125	140	155
7	5	#####	85	91	98	125	140	155
8	6	#####	81	97	99	125	140	155
9	7	#####	93	94	93	125	140	155
10	8	#####	93	92	93	125	140	155
11	9	#####	92	90	93	125	140	155
12	10	#####	90	88	93	125	140	155
13	11	#####	87	85	93	125	140	155

D02162007_0226
2-16-07

Figure 27: Data File Layout Example

Select a column to graph by clicking on the column header (A through H in the figure above).

To select multiple columns, click the first column header then hold down the Ctrl key and click the additional column headers. Columns C, E and G selected in the figure above.

Select Insert \Chart \ Line Chart. Select a chart sample and then click Finish.

A chart similar to the one below is displayed.

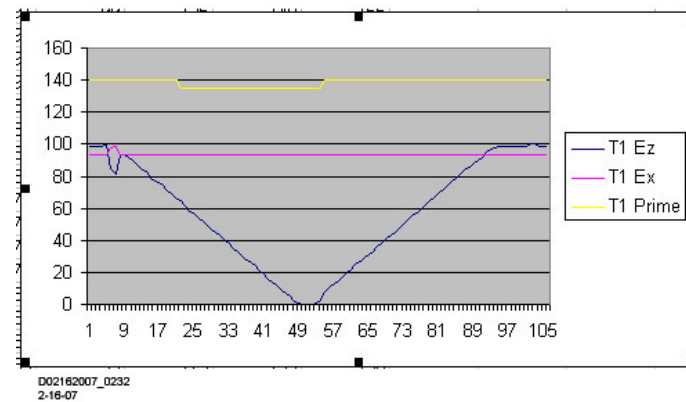

Figure 28: Prime, EZ, and EX Chart Example

The EX shown on the graph above is locked EX value, rather than the actual EX value, so when EX Limiting is set to **Yes**, even if EX is decreasing, it will not be shown to decrease on here.

APPENDIX A – HARDWARE

CHASSIS CONFIGURATIONS

Common Chassis Components

The various 5000 GCP chassis encountered in the field will have the following similarities (see Figure 30):

- Echelon connector location
- Chassis diagnostic port location, same as the DIAG (CP) port of the active CPU in dual units
- Battery/CPU interface connector location
- CPU Module connector location (left most card slot)
- CIC (Chassis Identification Chip) location
- ECD (External Configuration Device) location
- Grounding strap location
- Keyed Interface Connectors

CAUTION

Do not connect computers to the ESSR RJ45 connection. this connection supplies 12VDC to supply the essr radio. damage to the computer may occur if coupled to that connector.

NOTE

The keyed interface connectors used on the 5000 GCP front panel consist of both screw-down type and cage-clamp type connectors. Refer to page 16 for wire preparation and insertion instructions.

NOTE

On the A80907 chassis only, software versions gcp5K-3trk-0-1-0.mcf or later, the third track is referred to as Track-3 older versions refer to the third track as Track-5.

Track Card Compatibility

The GCP 5000 will need to be fitted with the ferrite bead kits K8018-1 as described in Appendix A and CSB 3-15E if it is to be used with any hardware version of the track module A80418.

If the GCP 5000 is restricted to using only the Rev L (and later) A80418 modules there is no need to install the ferrite beads kits and perform the additional island calibration steps described in the GCP5000 field manual SIG-00-13-03.

Two versions of the GCP 5000 MCF are available, starting at revision gcp5k-02-3.mcf, one that performs a check of the A80418 track module and one that does not. The specific MCF required can be ordered.

- Gcp5k-02-3.mcf

If this MCF is installed the GCP 5000 is able to operate with any version of GCP track module hardware. In this case ferrite beads must be fitted to prevent possible island shunting issues if Rev C or D track card are installed in the chassis.

- Rev L check MCF: gcp5k-trc-02-3.mcf

If this MCF is installed the GCP 5000 will only operate if A80418 Rev L modules (or later) are installed and these must be running executive software gcp04_70.mef (or newer). If this MCF is installed there is no need to install the ferrite beads kits on the chassis nor to perform the addition calibration step of checking the island Z and EZ values described in Table 12.

If a Rev D A80418 module is installed in the chassis running this MCF it will remain unhealthy and will display **VERS** on its display. See the trouble shooting section (Table 23) for a detailed description of diagnostic messages seen with various combinations of CPU and track software and hardware.

Note: This MCF can be used on the A80907 dual 3 track chassis, but track 3 will be labelled track 5. A gcp5K-3trk-xx-x.mcf is not yet available that enforces the Rev L track module compatibility.

CAUTION

Use proper primary surge protection on the track wires, GCP battery wires, and all GCP line circuits.

WARNING

If the GCP 5000 is used with an MCF that does not have 'trc' in the file name, the GCP 5000 chassis must have ferrite beads installed on the track XMT and RCV wires as described in Appendix A installation of ferrite beads in order to avoid possible shunting issues if a Rev D or earlier A80418 track module is installed in chassis.

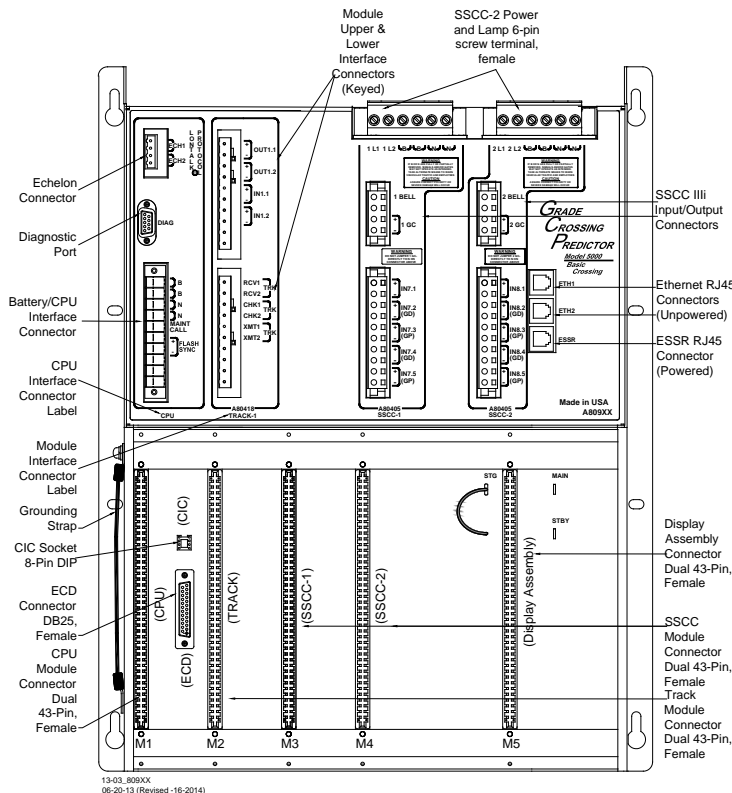

Figure 29: Common Chassis Component Locations

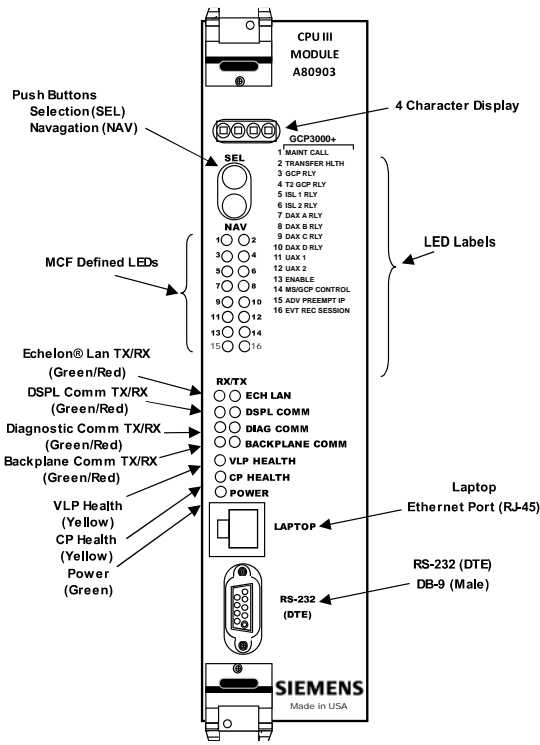

Figure 30: Central Processing Unit (CPU III A80903)

CPU MODULE USER INTERFACE (A80403)

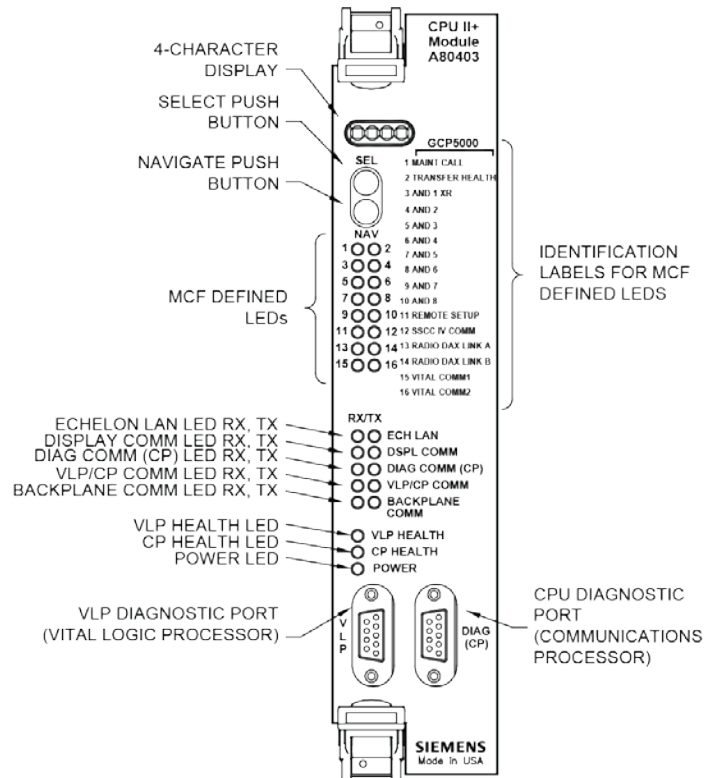

Figure 31: Central Processing Unit (CPU II+) Module, A80403,

Table 35: CPU Module LED Descriptions

LED		Function	Description
NAME	Color		
1 MAINT CALL	Red	Maintenance Call See page 78	On – maintenance call output on Off - maintenance call output off
2 TRANSFER HEALTH	Red	Transfer Output see page 79	On – transfer signal is being generated transfer card should not be counting down Off – transfer signal is not being generated If transfer card is in AUTO it should be counting down
3 AND 1 XR	Red	AND 1 XR	On – AND 1 XR is Energized Off – AND 1 XR is De-energized
4 to 10 AND 2 through AND 8	Red	AND 2 through AND 8	On – AND is Energized Off – AND is De-energized or Not Used
11 REMOTE SETUP	Red	Remote Setup Session	On – The GCP has been primed for a remote one-person setup (see Appendix F) Flashing – Remote setup in progress Off – No remote setup is in progress
12 SSCC IV COMM	Red	SSCCIV Echelon Active	On – External SSCC IV Echelon is in session Off – External SSCC IV Echelon not used or not in session
13 RDAX A/VCOM LINK 1	Red	Vital Comms Link A	On – Vital Comm Link 1 is in session (note RDAX A is for GCP4000)
14 RDAX B/VCOM LINK 2	Red	Vital Comms Link B	On – Vital Comm Link 2 is in session (note RDAX B is for GCP4000)
15 VCOM1 / VCOM LINK 3	Red	Vital Comm 1	On – Vital Comm Link 3 is in session (note VCOM1 is for GCP4000)
16 VCOM2 / VCOM LINK 4	Red	Vital Comm 2	On – Vital Comm Link 4 is in session (note VCOM2 is for GCP4000)
ECH LAN RX	Grn	Echelon Message Received	Flashes when the CPU is receiving an ATCS message via the Echelon LAN.

Table 35: CPU Module LED Descriptions

LED		Function	Description
NAME	Color		
ECH LAN TX	Red	Echelon Message Sent	Flashes when the CPU is transmitting an ATCS message via the Echelon LAN.
DSPL COMM RX	Grn	Display Port Message Received	Flashes when the CPU is receiving data from the Display module.
DSPL COMM TX	Red	Display Port Message Sent	Flashes when the CPU is sending data to the Display module.
DIAG COMM (CP) RX	Grn	Diag Port Message Received	Flashes when the CPU is receiving data from the communications processor diagnostic (DIAG CP) serial port.
DIAG COMM (CP) TX	Red	Diag Port Message Sent	Flashes when the CPU is transmitting data on the communications processor diagnostic (DIAG CP) serial port.
VLP/CP COMM RX (CPU II+ Only)	Grn	Comm Message Received	Flashes when the VLP is receiving data from the CP.
VLP/CP COMM TX (CPU II+ Only)	Red	Comm Message Sent	Flashes when the VLP is transmitting data to the CP.
BACK-PLANE COMM RX	Grn	Backplane Message Received	Flashes when the VLP is receiving data from the serial bus.
BACK-PLANE COMM TX	Red	Backplane Message Sent	Flashes when the VLP is sending data onto the serial bus.
VLP HEALTH	Yel	VLP Health Status	Flashes slowly (1Hz) when the CPU VLP is functioning normally. Flashes fast (4Hz) when the VLP is unhealthy
CP HEALTH	Yel	CP Health Status	Flashes slowly (1Hz) when the CP is functioning normally.
POWER	Grn	Power Indication	On steadily when power is applied to the module.

Table 36: CPU Module Display Messages

Display	Mode	Meaning	System State
MCF Name; e.g. GCP-T6X-02-1	Scrolling	VLP is healthy	CPU is healthy.
BOOT	Steady	CPU is booting up.	CPU is booting up. Crossing is activated.
CRC*	Steady	MCF CRC is incorrect for the current MCF	Entered CRC does not match CRC of MCF. Crossing is activated.
MCF*	Steady	CPU is not healthy because the MCF is not valid.	Reboot CPU or reload MCF. Crossing is activated.
SIN*	Steady	Site Identification Number is invalid.	Enter valid SIN. Crossing is activated.
VLP UCFG	Scrolling	VLP is unconfigured.	No comm to I/O modules. Crossing is activated.
VLP INITIAL	Scrolling	The CP is transferring the configuration from NVRAM to the VLP.	No comm to I/O modules. Crossing is activated.
CMCF / *MCF	Scrolling	The CP is copying the MCF from the ECD into flash memory.	No comm to I/O modules. Crossing is activated.
NO VLP COMMS	Scrolling	The CP is not communicating with the VLP. VLP could be rebooting or performing its initial configuration checks	No comm to I/O modules. Crossing is activated.
IP Address (CPU III Only)	Scrolling	Select button can be used to toggle between CP, VLP, and IP address.	CPU is healthy
EFLA	Steady	Erasing its flash memory in preparation for copying the MCF from the ECD into flash memory.	No comm to I/O modules. Crossing is activated.
ADR*	Steady	The radio DAXing neighbor ATCS address is invalid	Address of DAX session cannot be computed. Enter valid SIN
INI*	Steady	Rebooting	System Reboot - Crossing is activated.

Table 36: CPU Module Display Messages

Display	Mode	Meaning	System State
Exxx	Steady	Internal error, System will reboot. xxx is 3 digit hex number	Reload MCF - Crossing is activated.
LMCF	Steady	Rebooting	System Reboot - Crossing is activated.
ICLK	Steady	Rebooting	System Reboot - Crossing is activated.

NOTE

Steady messages may alternate with other messages.

The CPU has two processors: the Communications Processor (CP) and the Vital Logic Processor (VLP). When new software is installed into the CP, the VLP continues running without interruption until the CP setup is complete.

This means that if the Model 5000 GCP system is healthy and the crossing is not active, the VLP continues to correctly control the crossing while the new software installation into the CP is in progress. However, while the software transfer is in progress, the CP is not capable of logging state changes or communicating to the SEAR Ili.

Table 37: Setup Menu Display

Indication	Mode	Meaning
DOWNLOAD-ING SETUP	Scrolls	The setup program is being downloaded into the CP.
SETUP	Scrolls	The CP is in setup mode; i.e., MCF, MCF CRC, or CP MEF is being changed.
WAIT	Steady	CP is erasing flash memory.
WAITING FOR MEF	Scrolls	CP is waiting for a new MEF.
DOWNLOAD-ING MEF	Scrolls	A new MEF is being downloaded into the CP.
WAITING FOR MCF	Scrolls	CP is waiting for a new MCF.
DOWNLOAD-ING MCF	Scrolls	A new MCF is being downloaded into the CP.
DONE	Steady	Setup mode is ending.
BOOT	Steady	The CP is rebooting.

TRACK MODULE USER INTERFACE (A80418)

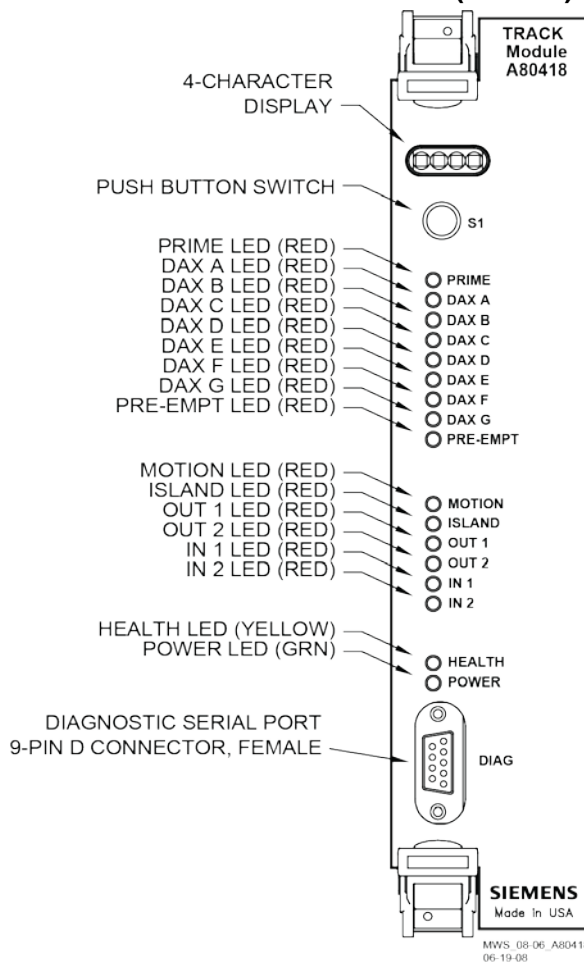

Figure 32: Track Module, A80418

Table 38: Track Module LED Descriptions

LEDs		DESCRIPTION
NAME	COLOR	
PRIME	Red	On – Prime predictor is energized Off – Prime predictor is de-energized or not used Flashing - Prime predictor is running the programmed pickup delay
DAX A	Red	On – DAX A predictor is energized Off – DAX A predictor is de-energized or not used Flashing – DAX A predictor is running its pickup delay
DAX B	Red	On – DAX B predictor is energized Off – DAX B predictor is de-energized or not used Flashing – DAX B predictor is running its pickup delay
DAX C	Red	On – DAX C predictor is energized Off – DAX C predictor is de-energized or not used Flashing – DAX C predictor is running its pickup delay

Table 38: Track Module LED Descriptions

LEDs		DESCRIPTION
NAME	COLOR	
DAX D	Red	On – DAX D predictor is energized Off – DAX D predictor is de-energized or not used Flashing – DAX D predictor is running its pickup delay
DAX E	Red	On – DAX E predictor is energized Off – DAX E predictor is de-energized or not used Flashing – DAX E predictor is running its pickup delay
DAX F	Red	On – DAX F predictor is energized Off – DAX F predictor is de-energized or not used Flashing – DAX F predictor is running its pickup delay
DAX G	Red	On – DAX G predictor is energized Off – DAX G predictor is de-energized or not used Flashing – DAX G predictor is running its pickup delay
PREEMPT	Red	On – Preempt predictor is energized Off – Preempt predictor is de-energized or not used Flashing – Preempt predictor is running its pickup delay
MOTION	Red	On – GCP has not detected motion Flash – GCP has detected motion below motion threshold Off – GCP has detected motion
ISLAND	Red	On – Island is unoccupied Off – Island is occupied Flashing – Island is running its pickup delay
OUT 1	Red	On – output energized Off – output de-energized or failed
OUT 2	Red	On – output energized Off – output de-energized or failed
IN 1	Red	On – input energized Off – input de-energized or failed
IN 2	Red	On – input energized Off – input de-energized or failed
HEALTH	Yellow	Slow (1Hz) – module is healthy and communicating with CPU. Fast (2Hz) – module is healthy but not communicating with CPU. Very Fast (4Hz) – module is unhealthy and communicating with CPU.
POWER	Green	On steadily when power is applied to the module

Table 38: Track Module LED Descriptions

LEDs		DESCRIPTION
NAME	COLOR	
*GCP	*blinks on and off, GCP steady	Module is healthy <ul style="list-style-type: none"> MS/GCP Operation is on No trains are detected on the approach
*ISL	*blinks on and off, ISL steady	Module is healthy <ul style="list-style-type: none"> MS/GCP Operation is programmed "not used" Island Operation is used
<i>Innn</i> e.g. I085	Steady	The module has detected inbound motion. EZ is given by the value 'nnn' (May appear different on older models)
<i>Snnn</i> e.g. S045	Steady	The module has not detected inbound or outbound motion. EZ is given by the value 'nnn' (May appear different on older models)
<i>Onnn</i> e.g. O049	Steady	The module has detected outbound motion. EZ is given by the value 'nnn' (May appear different on older models)
*CAL	Switches between *CAL and GCAL or ICAL	GCP Calibration in progress

Table 39: Track Module Display Indications (Operational)

Indication	Mode	Meaning	Module State
*APP	Switches between *APP and GAPP	GCP Approach calibration in progress	All predictors are de-energized
*LIN	Switches between *LIN and GLIN	GCP Linearization in progress.	All predictors are de-energized
ICAL	Blinks on and off	Island Calibration in progress	Island is de-energized

Table 40: Boot-up Messages

Indication	Mode	Meaning	Module State
BOOT	Steady	The module is rebooting	All predictors, island, inputs and outputs are de-energized
INIT	Steady	The module is performing its initialization	All predictors, island, inputs and outputs are de-energized

Table 41: Module State During Boot-up

Indication	Module State
BOOT	Rebooting
INIT	Initializing
GHWR	Checking Hardware
UCFG	The module is unconfigured and awaiting its configuration from the CPU.
GSTB /ISTB	The GCP and Island are stabilizing
*GCP	Module is healthy

Table 42: Software Installation Messages

Indication	Mode	Meaning
BOOT	Steady	The setup program is loaded into the CP, the module is in setup mode, or the module is having a new MEF Downloaded

DISPLAY MODULE, A80485-1

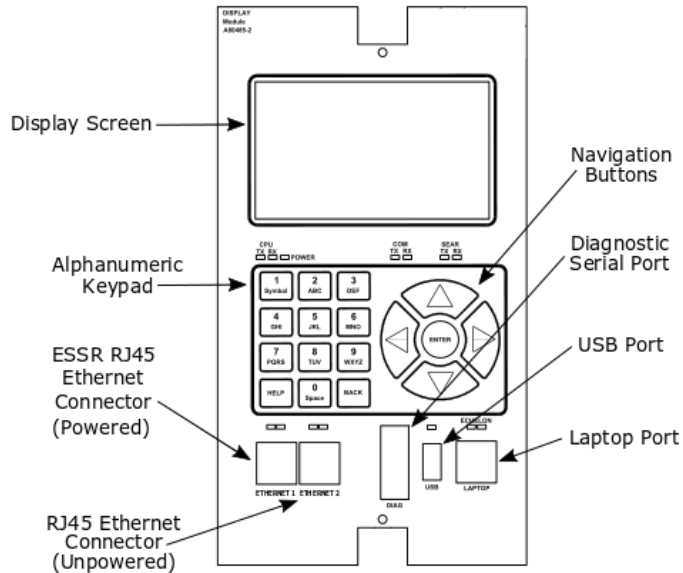

Figure 33: Display Module, A80485-1

SOLID-STATE CROSSING CONTROLLER (SSCC IIIi) MODULE USER INTERFACE (A80405)

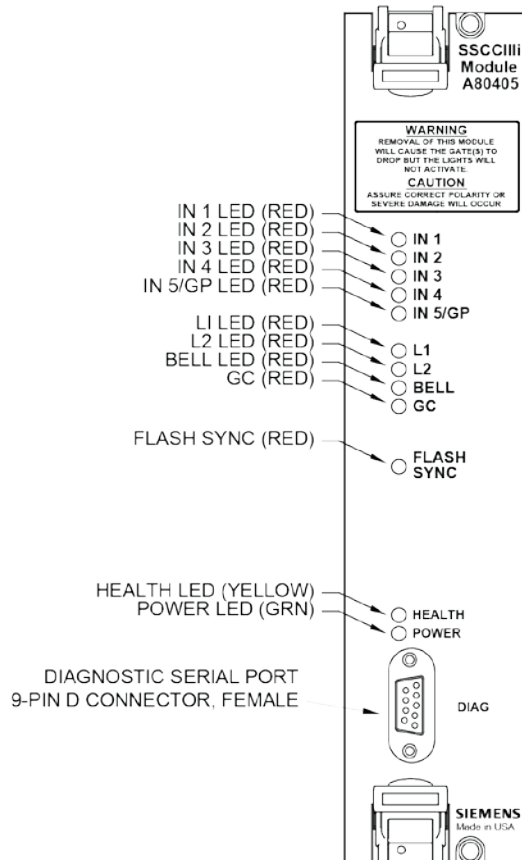

Figure 34: Solid State Crossing Controller IIIi (SSCC IIIi) Module, A80405

Table 43: SSCC IIIi LED Descriptions

LED		Description
Name	Color	
IN 1	Red	On – input 1 energized Off – input 1 de-energized
IN 2	Red	On – input 2 energized Off – input 2 de-energized
IN 3	Red	On – input 3 energized Off – input 3 de-energized
IN 4	Red	On – input 4 energized Off – input 4 de-energized
IN 5/Gate Position	Red	On – input 5 energized Off – input 5 de-energized
L1	Red	On – Lamp Output L1 is on Off – Lamp Output L1 is off
L2	Red	On – Lamp Output L2 is on Off – Lamp Output L2 is off
BELL	Red	On – bell output is on Off – bell output is off
GC	Red	On – gate control (GC) output is energized Off – gate control (GC) output is de-energized
FLASH SYNC	Red	Flashes when sync pulse is present at FLASH SYNC input/output
HEALTH	Yellow	Slow (1Hz) – module fully operational and communicating with CPU Fast (2Hz) – not communicating with CPU Very Fast (4Hz) – fault detected within the module
POWER	Green	On steadily when power is applied to the SSCC IIIi module

SSCC IIIi GENERAL INFORMATION

The A80405 Solid-State Crossing Controller IIIi (SSCC IIIi), Figure 35, is a plug-in module for the 5000 Grade Crossing Predictor (GCP). All multi-track 5000 GCP cases accommodate two A80405 modules. Each module provides:

- up to 20-amperes of lamp drive
- gate and bell control

A80405 module Interface is through GCP front-panel connectors.

- The A80405 module generally operates from a separate battery than the GCP portion of the system
- The SSCC IIIi modules are integrated into the 5000 GCP system. Wiring between the GCP, the SSCC IIIi, and the SEAR IIIi is eliminated.
- not redundant

Unit Overview

The A80405 module is programmed, calibrated, and tested from the Display module of the Model 5000 GCP, is activated by internal logic from the Model 5000 GCP, monitors gate position inputs from the crossing gate mechanism, and provides activation for the bell, lamps, and gates of a crossing warning system

Module Function Control

The following A80405 module functions may be programmed:

- Lamp flash rate
- Gate control delay
- Low battery threshold indication
- Control maintenance call output
- Test timer intervals
- Crossing and lamp tests
- Lamp flashing synchronization between the A80405 modules of multiple 5000 GCPs
- Disabling of crossing bells while the gates are rising
- Disabling of crossing bells while the gates are down requires gate down inputs to be energized

Crossing Controller Regulation for Lamp Voltage Outputs

- The circuits of the A80405 use pulse width modulation regulation
 - The pulsed output frequency is approximately 500 Hz.
 - The peak voltage of the pulse is approximately 1 volt below the battery input voltage.
 - Depending on the voltage in, the pulse width is automatically varied to give a regulated output.
 - The following examples assume the desired output is 10 volts:
 - Example 1: 16 volts in, the pulse is 15 volts and on 66% of the cycle.
 - Example 2: 13 volts in, the pulse is 12 volts and on 83% of the cycle.

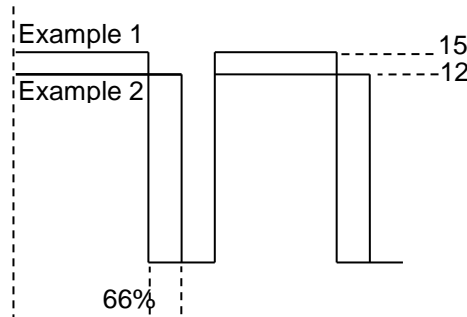

Figure 35: Pulse Width Modulation – Examples

NOTE

The regulated lamp drive is a pulse-width modulated voltage with an AC component and a DC component. A True RMS AC+DC meter is required to accurately read the pulse-modulated lamp voltage (i.e., Agilent model U1252A). Conventional multimeters may be used, however, the voltage reading will vary from the true rms value. The variance is not a set percentage and is dependent on battery voltage.

A conversion chart cross-referencing several conventional meters is in Using a Conventional Meter on Table 15.

Module Health

The CPU of the A80405 module provides an output that controls the HEALTH LED on the module front panel.

Yellow HEALTH LED reflects the health of the module:

- Flashes at 1 Hz rate when module fully operational.
- Flashes at 2 Hz rate when module not communicating with CPU module.
- Flashes at 8 Hz rate when fault is detected within the module.

Battery Surge Protection and Power Wiring

Battery surge protection for the SSCC is shown in Figure 37 below.

Primary surge protection for SSCC modules provided on SSCC battery (see inside dotted line)

Primary surge protection for I/O interconnect provided on lighting surge panels (see Page 140).

Provide power wiring to A80405 SSCC IIIi modules:

- Via **B** and **N** contacts of the respective crossing controller connectors on 5000 GCP front panel.
- Using poly-jacketed #10 AWG wire (recommended) for DC power and return between battery surge protection and the 5000 GCP crossing controller connectors.

Provide power wiring to the lighting surge panels:

- Using poly-jacketed #6 AWG wire (recommended) for DC power and return between the A91181-1 lighting surge panel and the crossing gate battery posts.

- Using poly-jacketed #10 AWG wire (recommended) for DC power and return between the A91181-1 lighting surge panel and the A91181-2 lighting surge panel'

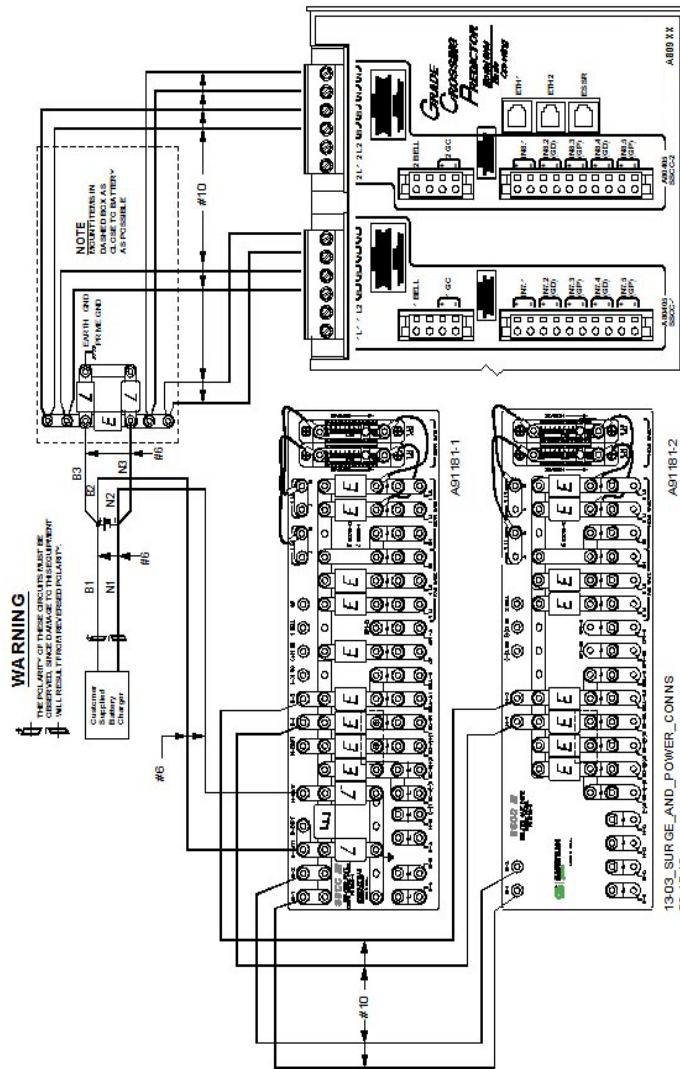

Figure 36: Surge & Power Connections to SSCC Modules & Lighting Surge Panels

Lighting Surge Panels

The A80405 modules use either of two SSCC III Lighting Surge Panel configurations to provide external I/O primary surge protection.

A91181-1, -2 isolated gate control, Figure 38A and Figure 38B

The Surge Panel configuration provides surge protection on all external I/O interconnects.

The SSCC III Lighting Surge Panels provide:

- arresters and equalizer for surge protection from transients on underground-cable battery voltage
- protection on all other I/O underground cable connections
- insulated links in the underground cable connections
- adjustable resistors in the **NEAR GATE** Lamp 1 (1 L1) and Lamp 2 (1 L2) circuits
- steering diodes for the Crossing Controller Gate Control output to provide isolation between the two crossing gate controls (see Figure 38)

For isolated gate control, a single A91181-1 panel (Figure 38A) is used for 20-ampere operation and both an A91181-1 and an A91181-2 panel (Figure 38B) are generally used for 21 to 40-ampere operation. Refer to Figure 39 for typical isolated gate control wiring.

NOTE

For information on the selection and installation of the 91181-1 SSCC III Lighting Surge Panels, refer to Page 140.

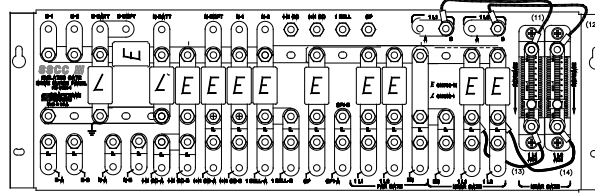

A: A91181-1

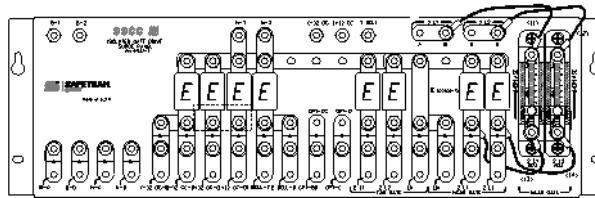

B: A91181-2

Figure 37: Isolated Return Lighting Surge Panels, A91181-1 & A91181-2

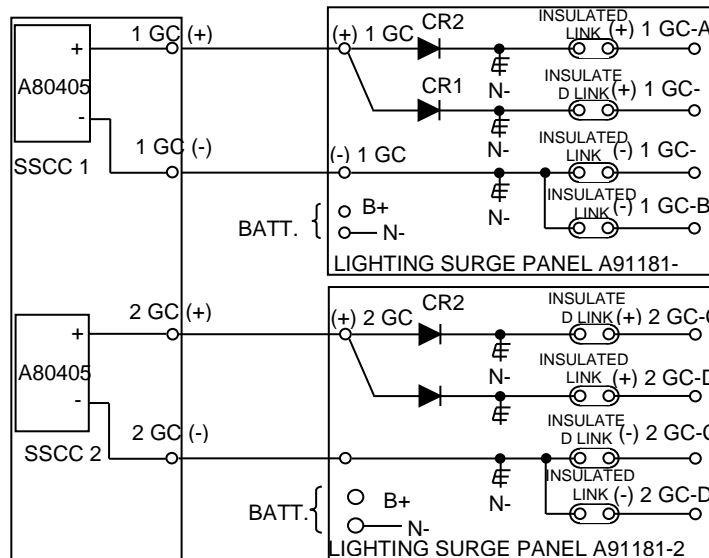

Figure 38: Typical Isolated Gate Control

SSCC IIIi OPERATION

The A80405 module provides drive for up to 20 amps of lamp current.

Failure Operation

The A80405 module continually performs self-diagnostic tests that result in complete testing of module operation.

- If a critical failure is detected, the appropriate signal states are generated to immediately flash the crossing lamps and bring down the gates.

⚠ WARNING

Removing input power from the A80405 module causes the gates to drop but the lamps are not activated.

If b or n are fully or partially removed, signals and/or gates may not operate as intended. Take alternate means to warn vehicular traffic, pedestrians and employees.

Crossing Controller Module Installation

Two non-redundant A80405 Solid-State Crossing Controller IIIi (SSCC IIIi) modules can be installed in the 5000. Crossing Controller lamp and bell circuit wiring includes:

- Installation of wiring between the 5000 GCP Crossing Controller connectors and the SSCC III Lighting Surge Panels
- Installation of underground wiring between the SSCC III Lighting Surge Panels and the crossing Mast Junction Boxes
- Use of SSCC III Lighting Surge Panel(s)

Where one signal is controlled by each Controller Module, one surge panel (-1) may be used for both modules.

⚠ WARNING

When one flashing light signal is controlled by each SSCC module, a single surge panel may be used. Jumper links from a to b must be removed in two places.

When two flashing light signals are controlled by a single SSCC module, a single surge panel may be used. Jumper links from a to b must be installed in two places.

Where two signals are controlled by a single Crossing Controller Module, one surge panel (-1) may be used. Where multiple signals are controlled by each Crossing Controller Module, an additional -2 surge panel is required and is wired and jumper links installed but connected to the second SSCC module connector.

Crossing Controller Connectors

The 5000 GCP Crossing Controller connectors accommodate all wiring between the A80405 module(s) and the 91181 SSCC III Lighting Surge Panel(s). Recommended crossing controller connector wire sizes are listed in Table 44.

- Use of stranded wire is recommended

Table 44: Minimum Recommended Crossing Controller Wire Sizes

External Wiring Connector	Pin	Connector Type	Wire Size
SSCC-1	1L1	6-pin screw terminal	10AWG
	1L2	6-pin screw terminal	10AWG
	B	6-pin screw terminal	10AWG
	N	6-pin screw terminal	10AWG
	1BELL	4-pin cage clamp	16AWG
	+1GC	4-pin cage clamp	16AWG
	-1GC	4-pin cage clamp	16AWG
	+1IN7.1	4-pin cage clamp	16AWG
	-1IN7.1	10-pin cage clamp	16AWG
	+IN7.2 (GD)	10-pin cage clamp	16AWG
	-IN7.2 (GD)	10-pin cage clamp	16AWG
	+IN7.3 (GP)	10-pin cage clamp	16AWG
	-IN7.3 (GP)	10-pin cage clamp	16AWG
	+IN7.4 (GD)	10-pin cage clamp	16AWG
	-IN7.4 (GD)	10-pin cage clamp	16AWG
	+IN7.5 (GP)	10-pin cage clamp	16AWG
-IN7.5 (GP)	10-pin cage clamp	16AWG	
SSCC-2	2L1	6-pin screw terminal	10AWG
	2L2	6-pin screw terminal	10AWG
	B	6-pin screw terminal	10AWG
	N	6-pin screw terminal	10AWG
	2BELL	4-pin cage clamp	16AWG
	+2GC	4-pin cage clamp	16AWG
	-2GC	4-pin cage clamp	16AWG
	+IN8.1	4-pin cage clamp	16AWG
	-IN8.1	10-pin cage clamp	16AWG
	+IN8.2 (GD)	10-pin cage clamp	16AWG
	-IN8.2 (GD)	10-pin cage clamp	16AWG
	+IN8.3 (GP)	10-pin cage clamp	16AWG
	-IN8.3 (GP)	10-pin cage clamp	16AWG
	+IN8.4 (GD)	10-pin cage clamp	16AWG
	-IN8.4 (GD)	10-pin cage clamp	16AWG
	+IN8.5 (GP)	10-pin cage clamp	16AWG
-IN8.5 (GP)	10-pin cage clamp	16AWG	



Crossing wiring must follow approved railroad schematics.

When installing b and n wires, observe correct polarity or severe damage to the A80405 module will occur. Use the correct size screwdriver blade to avoid connector damage. For wire preparation and insertion instructions, refer to page 6.

Lamp and Bell Wiring to the Lighting Surge Panel

Recommended wire size for L1 and L2 between the Lighting Surge Panel and the 5000 SSCC power connector is number 10 AWG.

- Recommended wire size between the Lighting Surge Panel and the Mast Junction Box is number 6 AWG.
- The Lighting Surge Panel should be mounted as close as practical to the 5000 GCP.

WARNING

Use caution when setting battery voltage, especially when using temperature compensated battery chargers:

Exceeding 16.5 VDC on crossing controller power terminals may result in intermittent false activations.

Exceeding 18 VDC will result in controller damage.

Observe correct polarity when connecting battery power to the b and n contacts on the crossing controller connector(s). Incorrect polarity will result in severe damage to the A80405 module(s).

Crossing Controller DC Power Connections

The A80405 modules receive power via the Lighting Surge panel and the CROSSING CONTROLLER connectors as shown in Figure 37:

Surge panel provides primary battery surge protection.

- Secondary surge protection provided by each A80405 module

Make power connections to each A80405 module via the B and N contacts of the respective CROSSING CONTROLLER connectors:

Poly-jacketed 10AWG wire is recommended for DC power and return between the lighting surge panel and the 5000 GCP.

Poly-jacketed 6AWG wire is recommended for DC power and return between the lighting surge panel and the crossing battery.

Connecting Power at Initial Cutover or After Changes to Warning Device Wiring

Once the system has booted up, the SSCC Illi module has internal short circuit protection for lamp, bell and gate control outputs. Therefore, at the initial cutover it is important to boot up the system prior to connecting external loads.

After external wiring is complete, the connectors must be applied as instructed in the following CAUTION before applying power to the 5000 GCP SSCC Illi module(s).

⚠ WARNING

During the SSCC IIIi boot-up process and after all wiring is connected:

The crossing gates will be down with crossing lamps flashing and bells ringing; A80405 module(s) will not be responsive to crossing control input from the 5000 GCP. Take adequate precautions to warn any pedestrians, personnel, trains, and vehicles in the area until proper system operation is verified.

⚠ CAUTION

The wiring and connectors must be applied in the following sequence to avoid damage:

Open the lamp, gate GC control, GP inputs, GD inputs and bell circuits at the surge panel(s).

Verify polarity on power connector(s).

Connect the screw-lock power connector for each SSCC IIIi module and lock by tightening screws.

Wait approximately 40 seconds for SSCC IIIi module(s) to boot up.

Connect the GC/bell and GP/GD cage-clamp connectors for the appropriate SSCC IIIi.

Close the lamp, gate control, GP/GD inputs and bell circuits on the surge panel(s).

RELAY INPUT OUTPUT (RIO) MODULE USER INTERFACE (A80413)

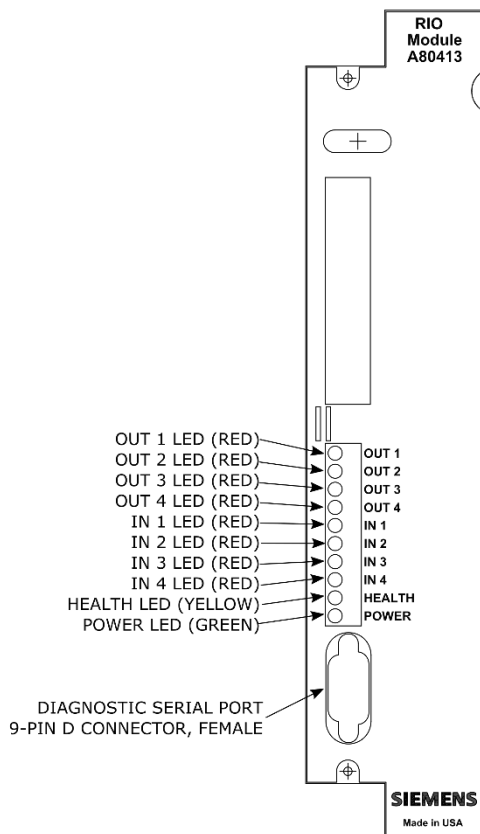

Figure 39: Relay Input Output Module (RIO), A80413

Table 45: RIO Module LED Descriptions

LED		Description
Name	Color	
OUT 1	Red	On – vital Output 1 energized Off – vital Output 1 de-energized
OUT 2	Red	On – vital Output 2 energized Off – Vital Output 2 de-energized
OUT 3	Red	On – vital Output 3 energized Off – vital Output 3 de-energized
OUT 4	Red	On – vital Output 4 energized Off – vital Output 4 de-energized
IN 1	Red	On – vital Input 1 energized Off – vital Input 1 de-energized
IN 2	Red	On – vital Input 2 energized Off – vital Input 2 de-energized
IN 3	Red	On – vital Input 3 energized Off – vital Input 3 de-energized
IN 4	Red	On – vital Input 4 energized Off – vital Input 4 de-energized
HEALTH	Yellow	Slow (1Hz) – module fully operational communicating with CPU Fast (2Hz) – module is not communicating with CPU Very Fast (4Hz) – fault detected within the module
POWER	Green	On steadily when power is applied to the RIO module

TRANSFER MODULES (A80406, A80468)

Two transfer modules are available depending on the 5000 GCP system chassis installed:

- A80406 Transfer Module - used in the Dual Four Track Chassis, A80400, and Dual Six Track Chassis, A80460.
- A80468 Transfer Module - used on the Dual Two Track Chassis, A80465.

The Timer Controls, LEDs, and Timer Display on each module function the same. Refer to Figure 41 and Figure 42 for control, LED and display locations.

WARNING

At crossings using MEFS xng02_00.mef and earlier, gates will begin to lower immediately (without gate delay time) when the transfer switch is used to swap between healthy units. Use caution when transferring control to avoid gates hitting vehicles or pedestrians.

NOTE

Under normal conditions in the AUTO Transfer mode, gate delay time will run when the gates initially operate. If the trouble continues, the gates will already be lowered when the Transfer Module later swaps units.

Transfer Module User Interfaces

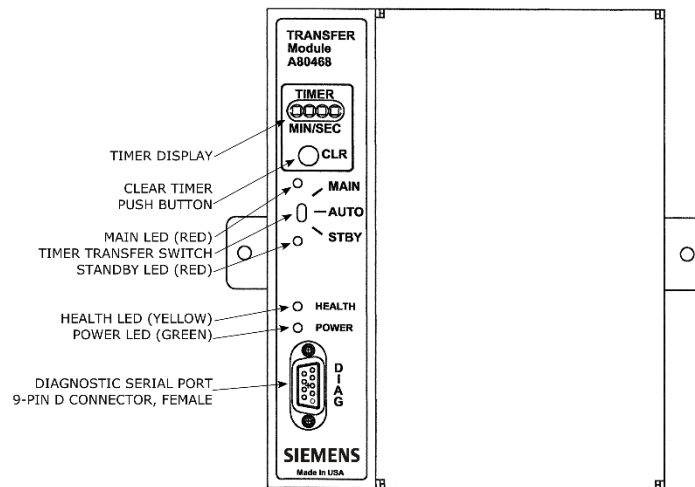

Figure 40: Transfer Module A80468, Front Panel

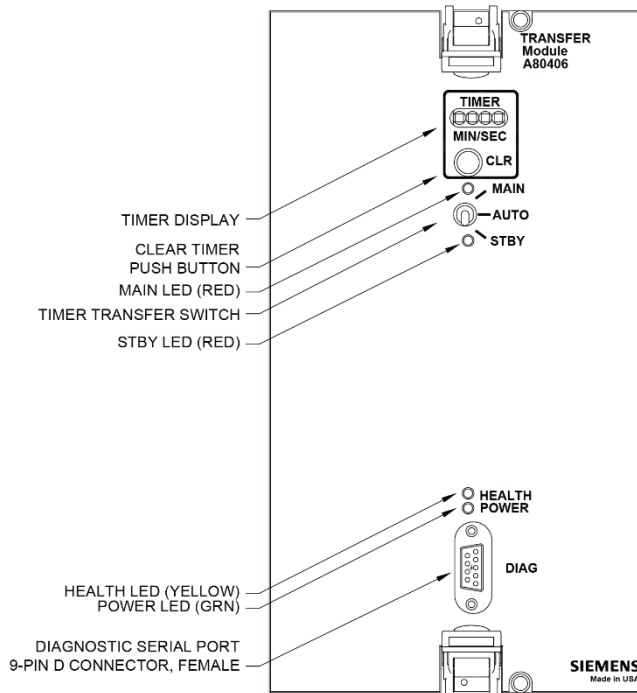

Figure 41: Transfer Module, A80406, Front Panel

Table 46: Transfer Module LED Descriptions

LED		Description
Name	Color	
MAIN	Red	On – Main modules enabled while Transfer Timer Switch is set to AUTO or Transfer Timer Switch is set to MAIN Off – Main side is currently not powered
STBY	Red	On – Standby modules enabled while Transfer Timer Switch is set to AUTO or Transfer Timer Switch is set to STBY Off – Standby side is currently not powered
HEALTH	Yellow	Slow (1Hz) – Module is functioning normally
POWER	Green	On steadily when power is applied to the Transfer module

When transfer delay is set using DIP switch S3, the Transfer Module 4-character display shows the:

- set transfer delay time in minutes and seconds
- transfer timer delay count down in 1 sec. increments
- selected module set (MAIN or STBY)

Table 47: Transfer Module Timer Display Indications

Indication	Mode	Meaning	Module State
MAIN	Steady	Timer Transfer switch is set to Main	Main side is powered
STBY	Steady	Timer Transfer switch is set to Standby	Standby side is powered
MMSS e.g. 0240 (2 mins 40 secs)	Steady	If the number is not changing, the module is set to AUTO. This represents the programmed transfer time.	Main or Standby side is powered
MMSS e.g. 0200 (2 mins 00 secs)	Decreasing	If the number is decreasing, the module is set to AUTO. The currently selected side is unhealthy and this number represents the time taken until a transfer occurs.	Main or Standby side is powered
MMSS alternating with SWCH	Steady	SWCH shows the module has transferred since the CLR button was pressed	Main or Standby side is powered

Table 48: Transfer Module Timer Controls

Item	Function
CLR (Clear Timer) push button	Clears transfer delay time from counter. When pressed during timer countdown: Sets the timer to the selected Transfer Delay Interval, and Initiates immediate transfer of GCP operation to opposite modules. Switches MAIN to STANDBY or Switches STANDBY to MAIN
Timer Transfer Switch	Three-position toggle switch: MAIN position enables only main module operation and will not automatically transfer. AUTO position enables automatic switch over to opposite set of modules: transfers from main modules to standby modules when main module failure is detected, or transfers from standby modules to main modules when standby module failure is detected. STBY position enables only standby module operation and will not automatically transfer. To switch from one set of modules (MAIN or STBY) to the other set of modules <u>when the transfer time is not counting down</u> , move the switch from AUTO to the desired position (MAIN or STBY). Then turn switch to AUTO.

Transfer Delay Interval Selection

The transfer delay interval for the transfer modules is set by the positions of the switch segments on switch assembly 3, (S3). The switch positions required to set the desired number of minutes are shown in Table 49; a similar table is located on each module. The delay range is 0 to 31 minutes, in 1 minute increments. The factory setting is 3 minutes.

Table 49: Transfer Delay Interval Settings

MINUTES	S3-0	S3-1	S3-2	S3-3	S3-4
0	0	0	0	0	0
1	1	0	0	0	0
2	0	1	0	0	0
3	1	1	0	0	0
4	0	0	1	0	0
5	1	0	1	0	0
6	0	1	1	0	0
7	1	1	1	0	0
8	0	0	0	1	0
9	1	0	0	1	0
10	0	1	0	1	0
11	1	1	0	1	0
12	0	0	1	1	0
13	1	0	1	1	0
14	0	1	1	1	0
15	1	1	1	1	0
16	0	0	0	0	1
17	1	0	0	0	1
18	0	1	0	0	1
19	1	1	0	0	1
20	0	0	1	0	1
21	1	0	1	0	1
22	0	1	1	0	1
23	1	1	1	0	1
24	0	0	0	1	1
25	1	0	0	1	1
26	0	1	0	1	1
27	1	1	0	1	1
28	0	0	1	1	1
29	1	0	1	1	1
30	0	1	1	1	1
31	1	1	1	1	1

0 is OPEN (UP, away from board).

1 is CLOSED (DOWN, towards board)

Bold numbers indicates default setting

NOTE

When viewing switch S3 with the transfer module in the normal operating position, the orientation of S3 on the A80468 module is inverted compared to the orientation of S3 on the A80406 module. This changes the location of switch position S3-0. Refer to Figure 43 and Figure 44 for switch position locations.

After changing switches on S3, verify timer setting by switching the timer transfer switch to AUTO. The transfer time (MM:SS) will be displayed in minutes and seconds on the 4-character display.

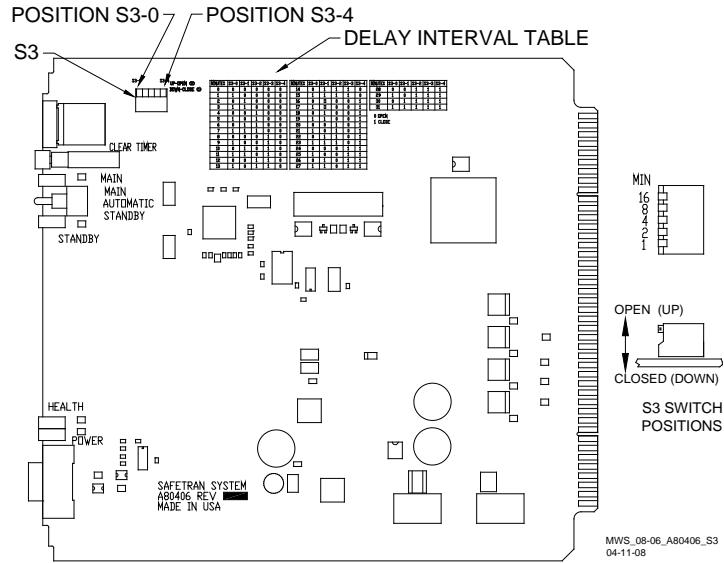

Figure 42: Transfer Module, A80406, S3 Switch Positions

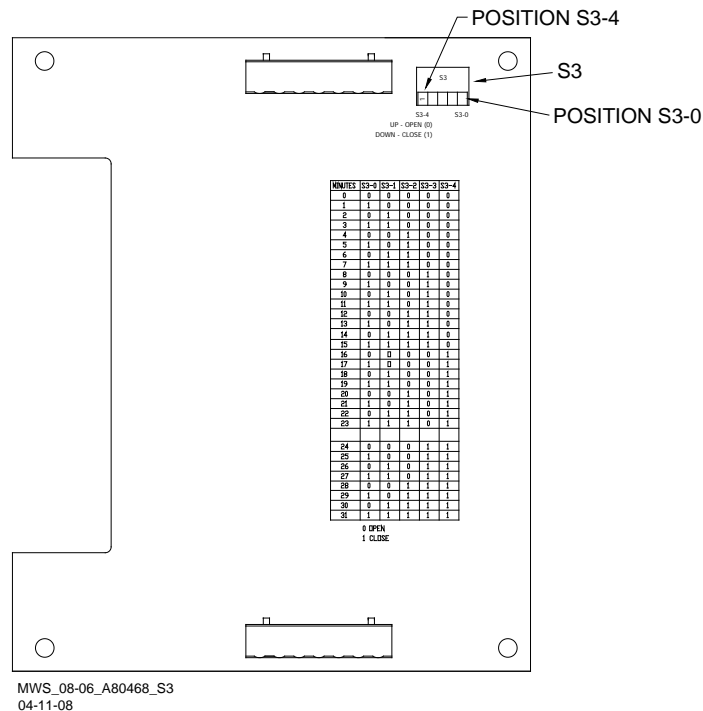

Figure 43: Transfer Module, A80468, S3 Switch Positions

Operation Without Transfer Module A80406

To disable the A80406 Transfer Module, remove the module from the chassis and move the jumper from the storage position, STG, to the MAIN or standby (STBY) position (see Figure 45).

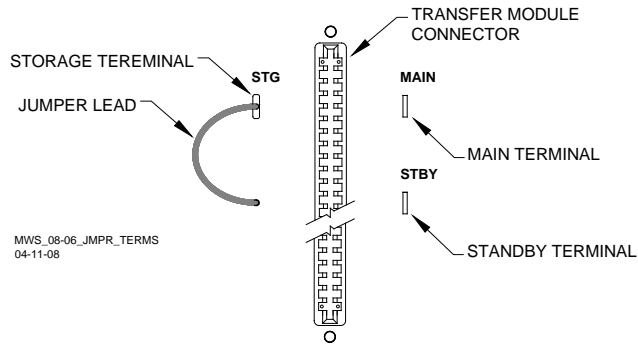

Figure 44: Transfer Module (A80406) Jumper Positions

Operation Without Transfer Module A80468

To disable the A80468 Transfer Module, remove the module from the chassis and move the jumper from the storage position, STG, to the MAIN or standby (STBY) position (see Figure 46 for all cases except A80475 or Figure 47 for the A80475).

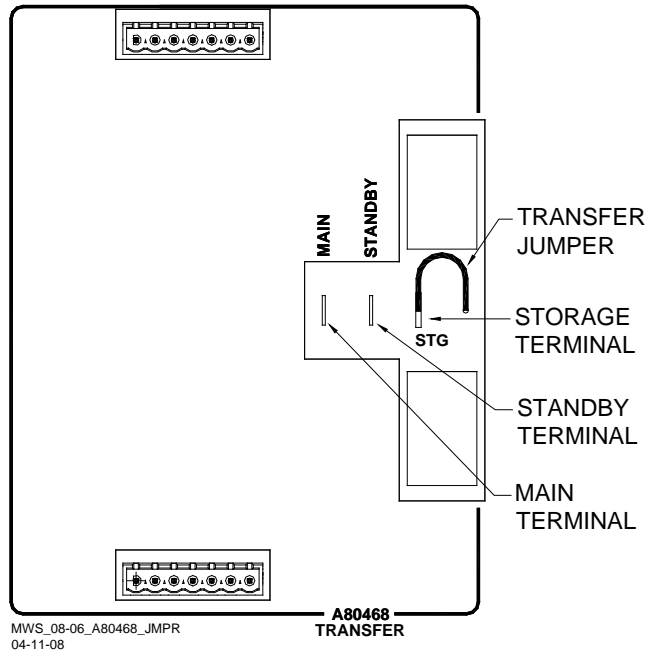
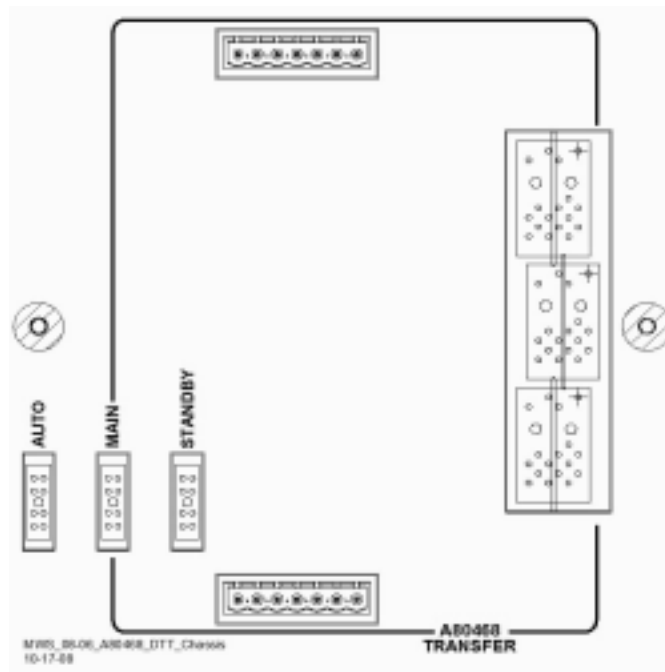

Figure 45: Transfer Module (A80468) Jumper Positions (All cases except A80475)



**Figure 46: Transfer Module (A80468) Jumper Positions
(Case A80475 Only)**

APPENDIX B –REMOTE CALIBRATION AND CROSSING LAMP VOLTAGE ADJUSTMENT

Optional remote GCP calibration and Crossing lamp voltage adjustment may be used as needed. The remote calibration and adjustment procedures are the same as the other procedures, except that the person doing the adjustment or calibration communicates directly with the GCP via VHF radio. The GCP sends voice options and the person performing the operation replies via a DTMF keypad on a VHF radio. The VHF Communicator is connected as depicted in Figure 48.

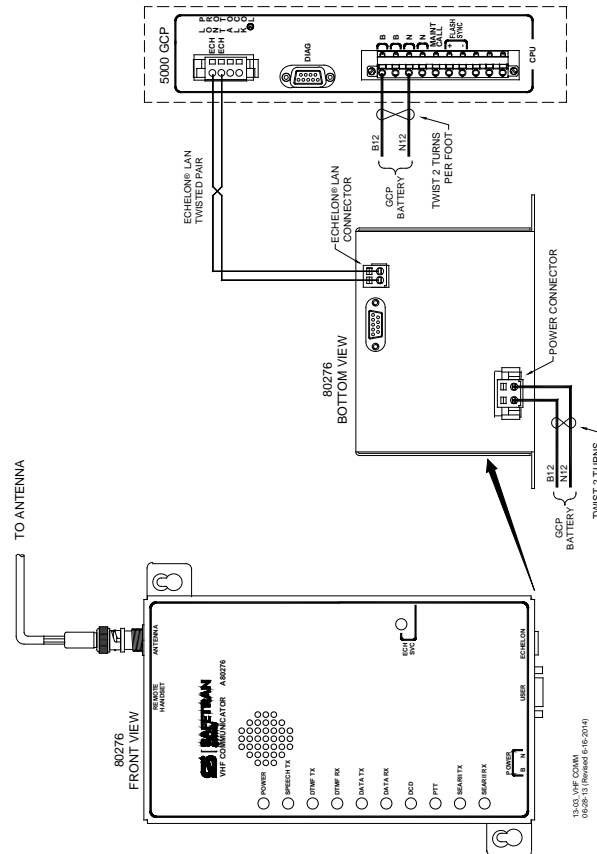

Figure 47: Connecting the VHF Communicator, A80276

REMOTE CALIBRATION EQUIPMENT REQUIREMENTS

To perform remote calibration and/or lamp adjustment the following are required:

5. Siemens Mobility, Inc. VHF Communicator (A80276) programmed and connected to the GCP Echelon LAN.
 - VHF Communicator is a VHF Radio interface to the 5000 GCP that sends setup and calibration options to remote radio.
 - VHF Communicator set to a railroad VHF frequency.
6. Hand-held VHF radio with DTMF keypad.
 - Person doing remote calibration responds to options and sends commands to GCP.
 - Set to same frequency as VHF communicator.
7. Hardwire test shunt for calibration and appropriate voltmeter for lamp adjustments.

SETUP SYSTEM FOR REMOTE CALIBRATION

NOTE

The GCP sends and receives commands via the VHF Communicator which includes a half-duplex radio. The radio cannot receive a reply until it is finished transmitting. DO NOT send back responses until the message is completed.

To enter a password or to select a value on the handheld VHF radio, press and hold the transmit button/key, then enter the numeric key values required.

A password must be preceded by an asterisk and a number symbol (*#) to be accepted as valid.

When an invalid password is received, the menu system is disabled for 30 seconds. When the menu system is reactivated (after 30 seconds), the correct password must be entered to continue.

After a valid password is entered, the system will respond with the DTMF tones for “##.”

Entering “##” at any time during remote operation returns the function to the initial Start position.

Prior to beginning remote calibration, the DOT Crossing Number must be entered. To set the DOT Number, scroll to **Program View>1) SITE Setup>1) Site Configuration**. The Site Configuration screen opens. Enter the DOT Number value from the information found in the approved drawings. During remote calibration, the DOT number is used to identify that the proper location is being calibrated.

REMOTE CALIBRATION OPERATIONS

This section includes flow charts for the commands and choices used in setup and calibration:

- Remote calibration setup
- Enable remote calibration and prime track
- Remote GCP calibration
- Remote approach and linearization calibration
- Remote island calibration
- Remote lamp voltage adjustment
- Remote calibration termination

Remote Calibration Setup

Table 50: Remote Calibration Setup

Step 1	Scroll to SYSTEM VIEW , and select the track to be calibrated, e.g., 1 – 6. The Track Options screen opens.
Step 2	From the Track Options screen, select 5) REMOTE SETUP . The Remote Setup dialog box displays.
Step 3	On the Remote Setup parameter where the word GET appears, select the Enter button. A Push button message appears in the message box at the bottom of the window.
Step 4	Press the SEL pushbutton on the front panel of the CPU module. The Remote Setup dialog box changes. A four-digit password appears in the Remote Password value field.
Step 5	Record the four-digit password.
Step 6	If calibrating track(s), scroll to Remote Cal Track “N” and select Enter . Scroll to True and select Enter . Set all tracks to be calibrated to True .
Step 7	If calibrating the SSCCs, scroll to Remote Cal SSCC and select Enter . Scroll to True and select Enter . Set all tracks to be calibrated to True .
Step 8	If the default 60-minute timeout is not long enough, scroll to Remote Setup Timeout (Min) and select Enter .
Step 9	Using the keypad numbers, enter the required Setup Timeout value (range 1 – 120 minutes) into the Remote Setup Timeout (min) screen.
Step 10	To perform an Island Calibration, go to the Island Calibration screen and record the shunt placement distance for shunting sensitivity.

WARNING

After performing remote GCP calibration using the VHF communicator, return to the 5000 GCP and verify that each calibration is properly implemented. Review the maintenance log or the CPU status log as part of the verification process.

Enable Remote Calibration for Track

NOTE

The figures beginning at Figure 49 and ending at Figure 53 provide a detailed flow chart of the “Remote User Interface Menu”.

Table 51: Enable Remote Calibration And Prime Track

Step 1	Press and hold the Transmit button/key of the hand-held VHF radio.
Step 2	Enter *# followed by the password recorded in Step 5 of Table 50.
Step 3	Release the Transmit button of the hand-held VHF radio. An assigned Department Of Transportation (DOT) number (XXX) is verbally announced. The Root menu options are announced: <ul style="list-style-type: none"> • “For location press 1” • “For GCP press 2” • “For SSCC press 3” • “For Help press 4”
Step 4	Press and hold the Transmit button/key then Press 2 . GCP is selected.
Step 5	Release the Transmit button. An “Enter track number” message is announced
Step 6	Press and hold the Transmit button/key. Enter the track number (N) to be calibrated (N = 1 to 6).
Step 7	Release the Transmit button. The Track Menu options are announced: <ul style="list-style-type: none"> • “For GCP calibration press 1” • “For approach calibration press 2” • “For linearization press 3” • “For island calibration press 4” • “To monitor EZ EX press 5” • “To monitor island press 6”

Remote GCP Calibration**Table 52: Remote GCP Calibration**

Step 1	To perform the GCP Calibration: <ul style="list-style-type: none"> • Press and hold the Transmit button/key then press 1. GCP calibration is selected.
Step 2	Release the Transmit button. The Calibration Menu options are announced: <ul style="list-style-type: none"> • “To start track N GCP calibration press 1” • “To monitor EZ EX press 2”
Step 3	Press and hold the Transmit button/key then Press 1 .
Step 4	Release the Transmit button. <ul style="list-style-type: none"> • “Enter password for DOT XXX” is announced.
Step 5	Press and hold the Transmit button/key, press *#, then enter the password recorded in Step 5 of Table 50.

Table 52: Remote GCP Calibration

Step 6	<p>Release the Transmit button. The following information messages are sequentially announced:</p> <ul style="list-style-type: none"> • “Initiating track N GCP calibration” • “Track N GCP calibration in progress” <p>If GCP calibration passes:</p> <ul style="list-style-type: none"> • The information messages are concluded with: <ul style="list-style-type: none"> • “Track N GCP calibration passed” • “EZ is ____” • “EX is ____” • The Track Menu options in Step 7 of Table 51 are repeated. <p>If GCP calibration fails:</p> <ul style="list-style-type: none"> • The information messages conclude with: • “Track N GCP calibration failed” • The calibration menu of Step 2 is repeated. • Refer to the Troubleshooting section beginning on page 51 for troubleshooting procedures. • When the cause of the failure is corrected, repeat this procedure starting at Step 3. <p>If the Remote Setup Timeout selected in Table 50 Step 6 expires, start again from Table 50</p>
Step 7	Begin remote approach calibration

Remote Approach and Linearization Calibration**Table 53: Remote Approach and Linearization Calibration**

Step 1	<p>Temporarily place a hardwire shunt across the termination shunt.</p> <ul style="list-style-type: none"> • For bidirectional installations, use the termination shunt farthest from the crossing
Step 2	<p>Press and hold the Transmit button/key then Press 2.</p> <ul style="list-style-type: none"> • Approach calibration is selected.
Step 3	<p>Release the Transmit button.</p> <ul style="list-style-type: none"> • The Calibration Menu options are announced: <ul style="list-style-type: none"> • “To start track N approach calibration press 1” • “To monitor EZ EX press 2”
Step 4	<p>Press and hold the Transmit button/key, then Press 1.</p>
Step 5	<p>Release the Transmit button.</p> <ul style="list-style-type: none"> • “Enter password for DOT” is announced.
Step 6	<p>Press and hold the Transmit button/key, press *#, then enter the password recorded in Step 5 of Table 50.</p>

Table 53: Remote Approach and Linearization Calibration

Step 7	<p>Release the Transmit button. The following information messages are sequentially announced:</p> <ul style="list-style-type: none"> • “Initiating track N approach calibration” • “Track N approach calibration in progress” <p>If approach calibration passes:</p> <ul style="list-style-type: none"> • The information messages conclude with: <ul style="list-style-type: none"> • “Track N approach calibration passed” • “Computed approach distance ____ ft” • Record this distance as the first approach distance. • The Track Menu options in Step 7 Table 51 are repeated. <p>If approach calibration fails the information messages conclude with:</p> <ul style="list-style-type: none"> • “Track N approach calibration failed” • The calibration menu in Step 3 is repeated. • Refer to the Troubleshooting section beginning on page 51 for troubleshooting procedures. • When the failure is corrected, repeat the procedure starting at Step 3. <p>If the Remote Setup Timeout selected in Table 50 Step 6 expires, start again from Table 50.</p>
Step 8	<p>Accurately (within 1%) locate the midpoint of the longest approach and move the hardwire shunt to that point on the rails.</p>
Step 9	<p>Press and hold the Transmit button/key and then Press 3.</p> <ul style="list-style-type: none"> • Linearization is selected.
Step 10	<p>Release the Transmit button. The Calibration Menu options are announced: “To start track N linearization press 1”</p> <ul style="list-style-type: none"> • “To monitor EZ EX press 2”
Step 11	<p>Press and hold the Transmit button/key then Press 1.</p>
Step 12	<p>Release the Transmit button. An “Enter password for DOT ____” directive is announced</p>
Step 13	<p>Press and hold the Transmit button/key, press *#, and then enter the password recorded in Step 5 of Table 50.</p>

Table 53: Remote Approach and Linearization Calibration

Step 14	<p>Release the Transmit button. The following information messages are sequentially announced:</p> <ul style="list-style-type: none"> • “Initiating track N linearization” • “Track N linearization in progress” <p>If linearization passes the information messages conclude with:</p> <ul style="list-style-type: none"> • “Track N linearization passed” • “Linearization number _____” • Record this number as the first approach value. • The Track Menu options, Step 7, Table 51, are repeated. <p>If approach linearization fails the information messages are concluded with:</p> <ul style="list-style-type: none"> • “Track N linearization failed” • Release the Transmit button. • The calibration menu from Step 10 is repeated. • Refer to the Troubleshooting section beginning on page 51 for troubleshooting procedures. • When the failure is corrected, repeat the procedure from Step 10.
Step 15	Remove the hardwire shunt from the track.
Step 16	<p>If the approach is unidirectional or simulated bidirectional, go to Step 38.</p> <p>If the track is bidirectional and the measured distance to the other termination shunt is within 10 % of the first approach go to Step 17.</p> <p>Otherwise, if distance is clearly shorter, go to Step 38.</p>
Step 17	Temporarily place a hardwire shunt across the termination shunt of the other approach.
Step 18	<p>Press and hold the Transmit button/key then Press 2.</p> <ul style="list-style-type: none"> • Approach calibration is selected.
Step 19	<p>Release the Transmit button, the Calibration Menu options are announced:</p> <ul style="list-style-type: none"> • “To start track N approach calibration press 1” • “To monitor EZ EX press 2”
Step 20	Press and hold the Transmit button/key, then press 1.
Step 21	<p>Release the Transmit button.</p> <ul style="list-style-type: none"> • “Enter password for DOT ____” is announced
Step 22	Press and hold the Transmit button/key, press *#, then enter the password recorded in Step 5 of Table 50.

Table 53: Remote Approach and Linearization Calibration

Step 23	<p>Release the Transmit button. The following information messages are sequentially announced:</p> <ul style="list-style-type: none"> • “Initiating track N approach calibration” • “Track N approach calibration in progress” <p>If approach calibration passes:</p> <ul style="list-style-type: none"> • The information messages conclude with: <ul style="list-style-type: none"> • “Track N approach calibration passed” • “Computed approach distance ____ ft” • Record this distance as the second approach distance value. • The Track Menu options in Step 7 of Table 51 are repeated. <p>If approach calibration fails, the information messages conclude with:</p> <ul style="list-style-type: none"> • “Track N approach calibration failed” • The calibration menu in Step 3 is repeated. • Refer to the Troubleshooting section beginning on page 51 for troubleshooting procedures. • When the failure is corrected, repeat the procedure starting at Step 3. <p>If the Remote Setup Timeout selected in Table 50 Step 6 expires, start again from Table 50.</p>
Step 24	<p>Accurately (within 1%) locate the midpoint of this approach and move the hardwire shunt to that point on the rails.</p>
Step 25	<p>Press and hold the Transmit button/key and then Press 4.</p> <ul style="list-style-type: none"> • Linearization is selected.
Step 26	<p>Release the Transmit button/key. The Calibration Menu options are announced:</p> <ul style="list-style-type: none"> • “To start track N linearization press 1” • “To monitor EZ EX press 2”
Step 27	<p>Press and hold the Transmit button/key, then Press 1.</p>
Step 28	<p>Release the Transmit button.</p> <ul style="list-style-type: none"> • An “Enter password for DOT ____” directive is announced
Step 29	<p>Press and hold the Transmit button/key, press *#, and then enter the password recorded in Step 5 of Table 50.</p>

Table 53: Remote Approach and Linearization Calibration

Step 30	<p>Release the Transmit button. The following information messages are sequentially announced:</p> <ul style="list-style-type: none"> • “Initiating track N linearization” • “Track N linearization in progress” <p>If linearization passes, the information messages conclude with:</p> <ul style="list-style-type: none"> • “Track N linearization passed” • “Linearization number _____” • Record this number as the second approach linearity value. • The Track Menu options, Step 7, Table 51, are repeated. <p>If approach linearization fails, the information messages are concluded with:</p> <ul style="list-style-type: none"> • “Track N linearization failed” • Release the Transmit button. • The calibration menu from Step 10 is repeated. • Refer to the Troubleshooting section beginning on page 51 for troubleshooting procedures. • When the failure is corrected, repeat the procedure from Step 10.
Step 31	<p>Remove the hardwire shunt from the track.</p>
Step 32	<p>If the Lin Steps value for the second approach is greater than or the same as the value recorded for the first approach in Step 14, record the Lin Steps value, then go to Step 38.</p> <p>If the Lin Steps value for the second approach is less than the value recorded in Step 14, return to the bungalow and select the EDIT button of the track Linearization calibration menu.</p> <ul style="list-style-type: none"> • The Linearization Steps dialog box displays.
Step 33	<p>Enter the Lin Steps value recorded for the first approach in Step 14 into the New Value field using the keypad numbers and select UPDATE.</p>
Step 34	<p>Select the GCP APP button.</p> <ul style="list-style-type: none"> • The GCP Approach Window appears.
Step 35	<p>Select the EDIT button.</p> <ul style="list-style-type: none"> • The Computed Approach Distance dialog box appears.
Step 36	<p>Enter the computed approach distance (Comp Dist) value recorded for the first approach in Step 5 into the New Value field using the keypad numbers and select UPDATE.</p> <ul style="list-style-type: none"> • The Calibration Select Window appears.
Step 37	<p>Verify that the computed approach distance (Comp Dist) and the linearization steps (Lin Steps) values recorded for the first approach in Steps 14 and 30 are the same as those displayed on the Calibration Select window</p>
Step 38	<p>Enter the distance and linearity values recorded for the first and second (if applicable) approach(es) on the CALIBRATION VALUES history on page 21 of the Application History card.</p>

Table 53: Remote Approach and Linearization Calibration

Step 39	<p>This completes Approach and Linearization calibration.</p> <p>To record the reason for the Calibration and store it in the Maintenance log, select the ADD LOG ENTRY button.</p> <ul style="list-style-type: none"> Type any notes about the calibration and select OK to save the entry.
----------------	--

Remote Island Calibration

Table 54: Remote Island Calibration

Step 1	<p>Temporarily install a hardwire shunt beyond the island receiver rail connections.</p> <ul style="list-style-type: none"> Place the shunt at the distance recorded in Table 50, Step 12.
Step 2	<p>Press and hold the Transmit button/key then press 6.</p> <ul style="list-style-type: none"> Island calibration is selected.
Step 3	<p>Release the Transmit button.</p> <p>The Calibration Menu options are announced:</p> <ul style="list-style-type: none"> “To start track N island calibration press 1” “To monitor island signal level press 2”
Step 4	<p>Press and hold the Transmit button/key, then press 1.</p>
Step 5	<p>Release the Transmit button/key.</p> <ul style="list-style-type: none"> An “Enter password for DOT ___” message is announced
Step 6	<p>Press and hold the Transmit button/key, then enter the password recorded in Step 5 of Table 50.</p>
Step 7	<p>Release the Transmit button, the following information messages are sequentially announced:</p> <ul style="list-style-type: none"> “Initiating track N island calibration” “Track N island calibration in progress” <p>If island calibration passes:</p> <ul style="list-style-type: none"> The information messages conclude with: “Track N island calibration passed” “Island signal level n” (where n is around 100). The Track Menu options in Step 7 Table 51 are repeated. <p>If island calibration fails, the information messages conclude with:</p> <ul style="list-style-type: none"> “Track N island calibration failed” Release the Transmit button. The calibration menu from Step 3 is repeated. Refer to the Troubleshooting section beginning on page 51 for troubleshooting procedures. When the failure is corrected, repeat the procedure starting at Step 2.
Step 8	<p>Remove the hardwire shunt.</p>

Remote Lamp Voltage Adjustments

NOTE

Before performing the remote lamp voltage adjustment procedure, the crossing controllers must be inactive; i.e. gates up, lamps off, and bell off. If a train approaches during lamp adjustment, the crossing controllers will activate and the lamps will flash.

Table 55: Remote Lamp Voltage Adjustments

Step 1	Press and hold the Transmit button/key. Press 3 . <ul style="list-style-type: none"> The remote SSCC menu is selected.
Step 2	Release the Transmit button. The SSCC Menu options are announced: <ul style="list-style-type: none"> “SSCC 1 press 1” “SSCC 2 press 2” “Crossing press 3”
Step 3	Press and hold the Transmit button/key, then Press 1 . <ul style="list-style-type: none"> The SSCC Lamp 1 Menu is selected.
Step 4	Release the Transmit button. The SSCC 1 Lamp Menu options are announced: <ul style="list-style-type: none"> “Lamp 1 press 1” “Lamp 2 press 2” “Lamp 1 voltage press 3” “Lamp 2 voltage press 4”
Step 5	Press and hold the Transmit button/key, then Press 3 .
Step 6	Release the Transmit button. <ul style="list-style-type: none"> “SSCC 1 lamp 1 voltage ___ volts” is announced
Step 7	Press and hold the Transmit button/key, then Press * . <ul style="list-style-type: none"> The SSCC 1 Lamp 1 Voltage Menu is selected.
Step 8	Release the Transmit button. “SSCC 1 Lamp 1 Voltage” is announced, followed by: <ul style="list-style-type: none"> “up 1 volt press 1” “up one-half volt press 2” “up one-tenth volt press 3” “down 1 volt press 4” “down one-half volt press 5” “down one-tenth volt press 6” SSCC 1 lamp 1 output is on and steady.
Step 9	Press and hold the Transmit button/key, then press the number required to appropriately increment the voltage level at lamp 1.
Step 10	Release the Transmit button. <ul style="list-style-type: none"> “SSCC 1 lamp 1 voltage ___ volts” is announced.
Step 11	Repeat Step 9 and 10 until the specified voltage reading is obtained at lamp 1. <ul style="list-style-type: none"> Measure the voltage at lamp 1 using the correct meter (see Page 33).

Table 55: Remote Lamp Voltage Adjustments

Step 12	<p>Press and Hold the Transmit button/key, then Press *.</p> <ul style="list-style-type: none"> The SSCC 1 Lamp Menu is selected.
Step 13	<p>Release the Transmit button.</p> <ul style="list-style-type: none"> The new lamp 1 voltage value is saved. The lamp 1 output is turned off. The SSCC 1 Lamp Menu options are announced: “Lamp 1 press 1” “Lamp 2 press 2” “Lamp 1 voltage press 3” “Lamp 2 voltage press 4”
Step 14	<p>Press and hold the Transmit button/key, then Press 4.</p>
Step 15	<p>Release the Transmit button.</p> <p>“SSCC 1 lamp 2 voltage ___ volts” is announced</p>
Step 16	<p>Press and hold the Transmit button/key, then Press *.</p> <ul style="list-style-type: none"> The SSCC 1 Lamp 2 Voltage Menu is selected.
Step 17	<p>Release the Transmit button. “SSCC 1 Lamp 2 Voltage” is announced, followed by:</p> <ul style="list-style-type: none"> “up 1 volt press 1” “up one-half volt press 2” “up one-tenth volt press 3” “down 1 volt press 4” “down one-half volt press 5” “down one-tenth volt press 6” SSCC 1 lamp 2 output is on and steady.
Step 18	<p>Press and hold the Transmit button/key, then press the number required to appropriately increment the voltage level at lamp 2.</p>
Step 19	<p>Release the Transmit button.</p> <ul style="list-style-type: none"> “SSCC 1 lamp 2 voltage ___ volts” is announced.
Step 20	<p>Repeat Steps 18 and 19 until the specified voltage reading is obtained at lamp 2.</p> <ul style="list-style-type: none"> Measure the voltage at lamp 2 using the correct meter (see Page 33).
Step 21	<p>Press and hold the Transmit button/key, then Press *.</p> <ul style="list-style-type: none"> The SSCC 1 Lamp Menu is selected.
Step 22	<p>Release the Transmit button. The new voltage value is saved and the lamp 1 output is turned off.</p> <p>The SSCC 1 Lamp Menu options are announced:</p> <ul style="list-style-type: none"> “Lamp 1 press 1” “Lamp 2 press 2” “Lamp 1 voltage press 3” “Lamp 2 voltage press 4”
Step 23	<p>Press and hold the Transmit button/key, then Press *.</p> <ul style="list-style-type: none"> The SSCC Menu is selected.

Table 55: Remote Lamp Voltage Adjustments

Step 24	Release the Transmit button. The SSCC Menu options are announced: <ul style="list-style-type: none">• “SSCC 1 press 1”• “SSCC 2 press 2”• “Crossing press 3”
Step 25	Press and hold the Transmit button/key, then Press 2.
Step 26	Release the Transmit button. The SSCC 2 Lamp Menu options are announced: <ul style="list-style-type: none">• “Lamp 1 press 1”• “Lamp 2 press 2”• “Lamp 1 voltage press 3”• “Lamp 2 voltage press 4”
Step 27	Repeat Steps 5 through 20 for SSCC 2.

Terminate Remote Calibration

Table 56: Terminate Remote Calibration

Step 1	Repeat all remote procedures for each track module selected in the Remote Calibration steps.
Step 2	To terminate the remote session: <ul style="list-style-type: none">• Press and hold the Transmit button/key then press *##.
Step 3	Release the Transmit button. The remote setup is finished
Step 4	Return to the bungalow and check the Status log to ensure that the tracks were correctly calibrated. To access the Status Log, use the Display module to scroll to Diag & Reports > 3) Reports & Logs > 2) Logs > 4) CPU-Card IO Logs > 1) Status Log.

REMOTE USER INTERFACE MENU

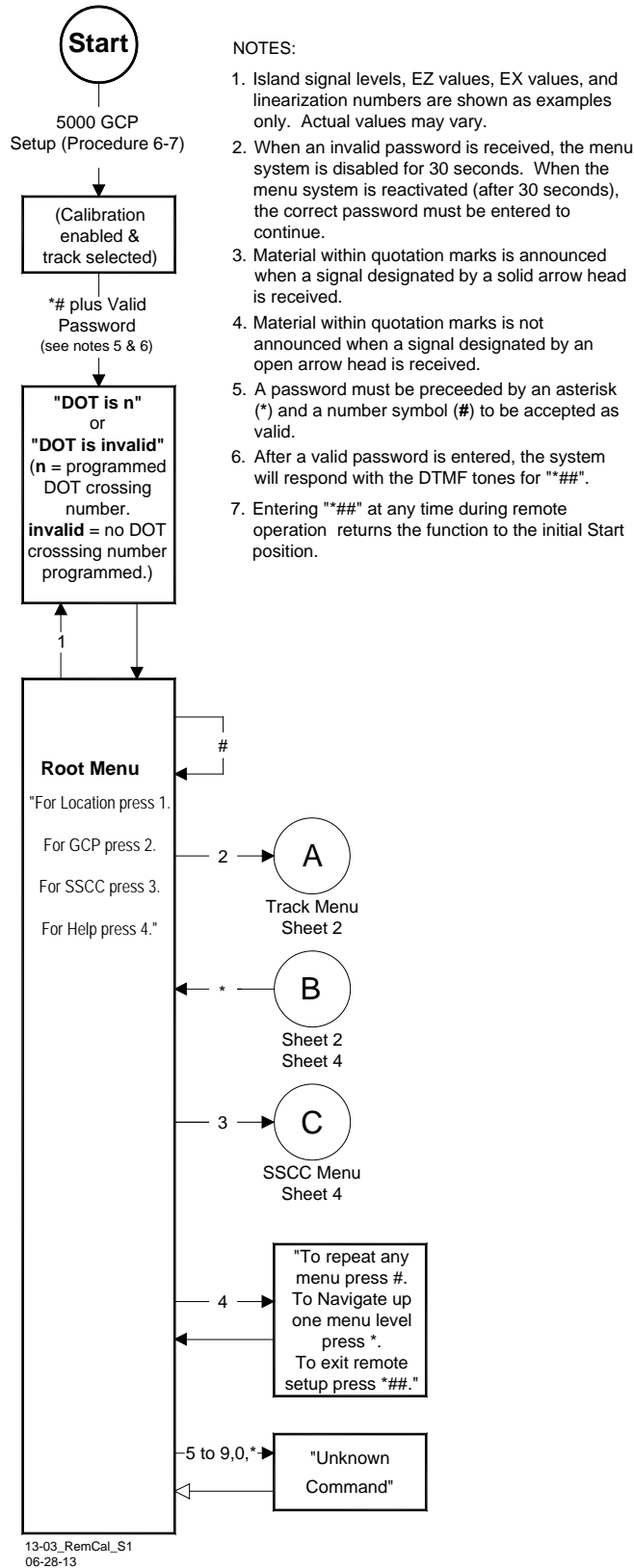

Sheet 1

Figure 48: Remote User Interface Menu, Sheet 1

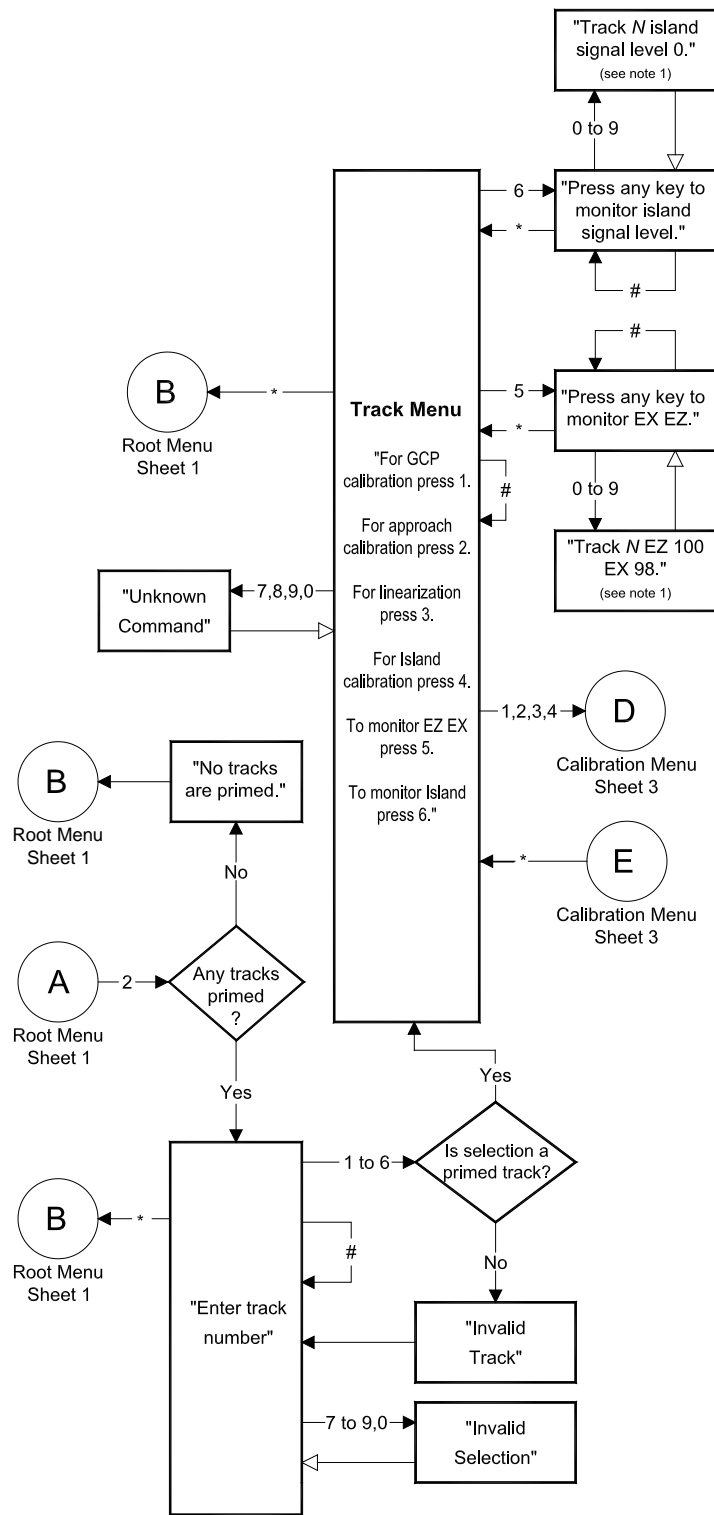

Figure 49: Remote User Interface Menu, Sheet 2

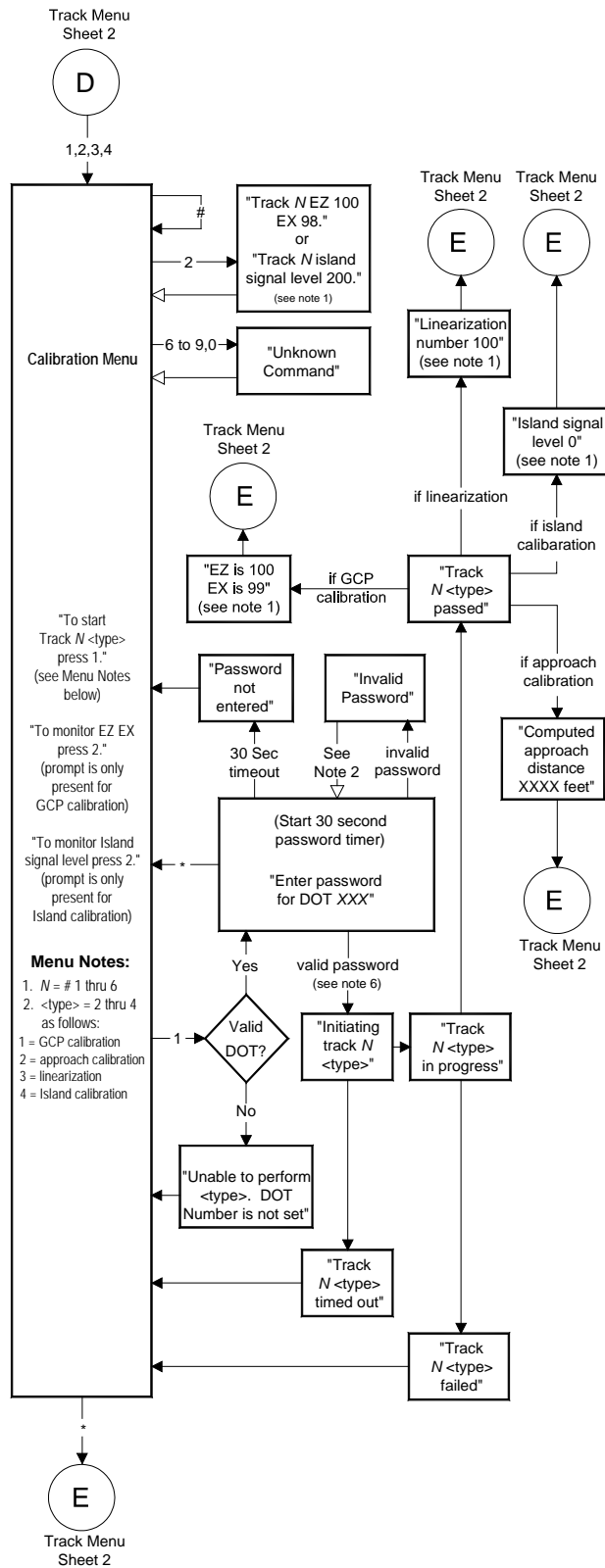

Figure 50: Remote User Interface Menu, Sheet 3

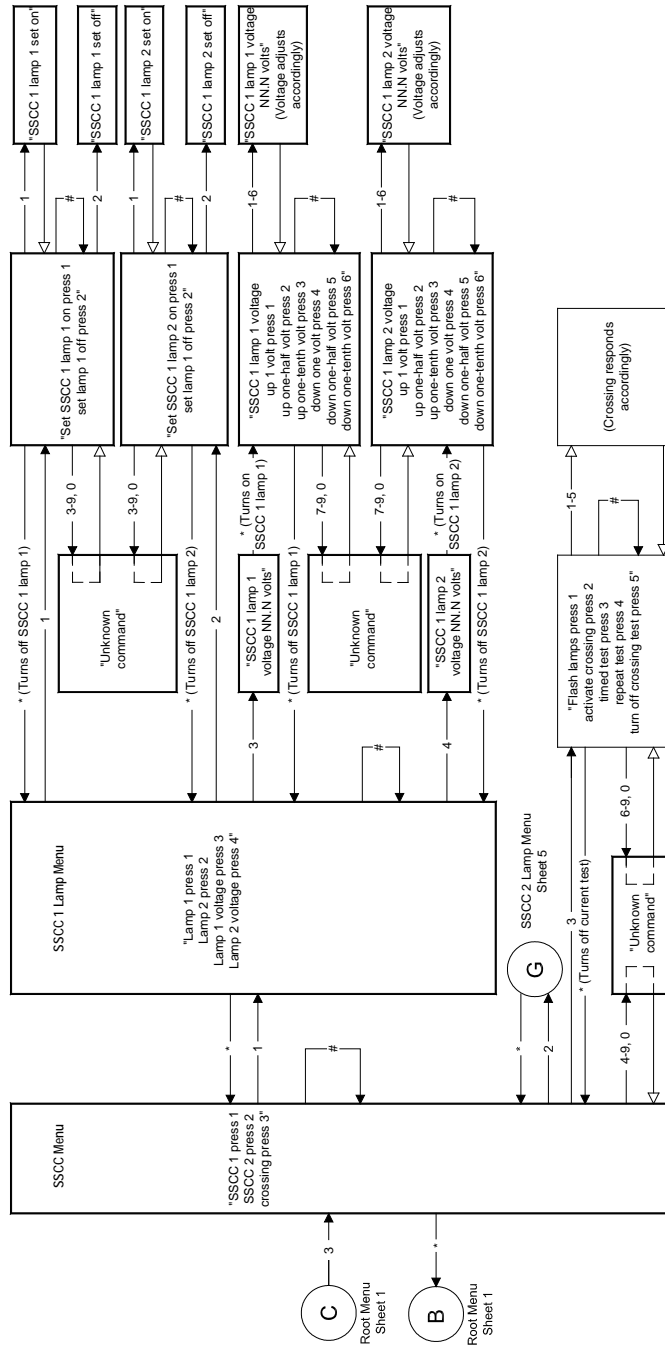

Figure 51: Remote User Interface Menu, Sheet 4

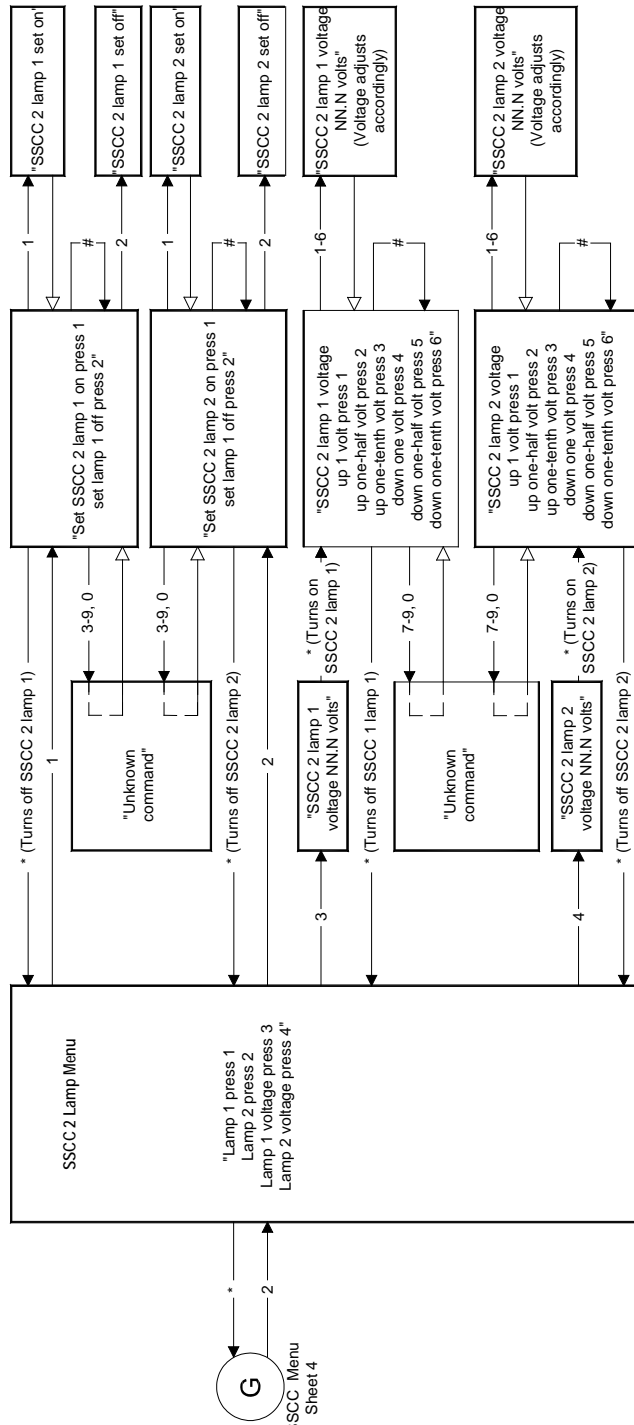

Figure 52: Remote User Interface Menu, Sheet 5

APPENDIX C – GLOSSARY

GLOSSARY

Advance Preemption:	Notification of an approaching train is forwarded to the highway traffic signal controller by railroad equipment in advance of activating the railroad active warning devices.
Advance Preemption Time:	This period of time is the difference in the Maximum Preemption Time required for highway traffic signal operation and the Minimum Warning Time needed for railroad operation.
AND:	AND circuits require all inputs to be energized for the output to be energized.
AND ENABLE:	An internal function that can be used to 'connect' an input to an AND circuit.
AND 1 XR:	The AND function that controls the local crossing. Is equivalent to the XR relay.
AND 2 through 12:	Internal functions that are used to combine inputs.
ATCS:	Advanced Train Control System – An industry standard used in the 5000 GCP for communications.
CCN:	Configuration Check Number – The 32 bit CRC of the configuration data.
CDL:	Control Descriptor Language – The programming language used by application engineers to customize the operation, settings, and behavior of a SEAR II/III.
CHK:	CHECK receiver on a track module connected to transmit wires that perform track wire integrity checks.
CHK EZ:	Check EZ is a signal value compared to main receiver EZ that is useful in troubleshooting.
CIC:	Chassis Identification Chip - A non-volatile memory chip that is installed adjacent to the ECD on the GCP backplane. Stores site specific information for both Main and Standby operations.
Computed Approach Distance:	The track approach length calculated by the GCP. The calculated distance between the wire connections on the rail and the termination shunt connections.
CP:	Communications Processor – One of two microprocessors on the CPU module, processes external communications for the GCP 5000.
CRC:	Cyclical Redundancy Check - Used to determine that data has not been corrupted.
CRTU:	Cellular Remote Telemetry Unit
DAX:	Acronym for Downstream Adjacent Crossing (Xing). DAX outputs are used to send prediction information from an upstream GCP to a downstream GCP when insulated joints are in the approach circuit.
DIAG:	Diagnostic
Directionally Wired	Setting used to enable the GCP to determine train direction.
Directional Stick Logic	The logic function used to determine direction of train movement. The output of this function is used to activate/deactivate associated signal systems.

GLOSSARY

DOT Number:	Department Of Transportation crossing inventory number assigned to every highway-railroad crossing that consists of six numbers with an alpha suffix.
Drop Delay	An internal delay time between when a function is ordered off and when it actually de-energizes.
DT:	Diagnostic Terminal – The Diagnostic Terminal (DT) is a Siemens Mobility, Inc. developed Windows® based software that can run on the Display module or on a PC, which allows the user to perform programming, calibration, and troubleshooting.
DTMF:	Dual Tone Multi-Frequency - The tones on a telephone or radio keypad.
ECD:	External Configuration Device – The non-volatile memory device on the GCP backplane used for storing the module configuration file.
Echelon:	A Local Area Network, LAN, used by the 5000 GCP.
EGOM	Exit Gate Operating Mode – A dynamic mode in which the exit gate operation is based on the presence and detection of vehicles between the stop bar or entrance gate and the exit gate.
Enhanced Detection:	User selectable process that detects nonlinear fluctuations in track signal due to poor shunting and temporarily switches the track module from predictor to motion sensor.
Entrance Gate:	A gate used at the entrance to a highway-railroad grade crossing, which is designed to release and lower by gravity from the full vertical position to the horizontal position under a loss of power condition or when the control energy (GC) is removed.
EX:	The EX value is a numerical indication of track ballast conditions relative to the leakage resistance between the rails. A value of 100 represents nominal good ballast. A value of 39 represents very poor ballast.
Exit Gate:	A gate used at the exit from a highway-railroad grade crossing with Four Quadrant Gates to restrict wrong direction vehicular movements, which is designed to raise by gravity from the horizontal position to a vertical position great enough to allow vehicle clearing under a loss of power condition or when the control energy (GC) is removed.
FAR GATE:	On the same surge panel, the 'far gate' is the flashing light signal or gate with the largest voltage drop in the cable circuit. In general, if both signals have the same number and type of lamps and the same size cable conductors, the 'far gate' is the location with the longest cable run. The 'far gate' circuit on the surge panel does not have an adjustable resistor in series with L1 and L2 that provides voltage adjustment.
FCN	Field Check Number. The 32 bit CRC of the configuration data, including items that are protected by the Maintainer Password.

GLOSSARY

Maintainer Password	The password set that allows field maintenance personnel access to field editable parameters.
Flash Memory:	A type of non-volatile memory that can be reprogrammed in-circuit via software.
Gate Delay Period:	The programmable time period from when the lights begin to flash until the gates begin to descend.
GC:	Gate Control
GCP:	Grade Crossing Predictor – A train detection device used as part of a highway-railroad grade crossing warning system to provide a relatively uniform warning time.
GCP APP:	GCP Approach length calibration into a hardwire shunt located at the termination shunt.
GCP CAL:	GCP Calibration into a termination shunt.
GCP LIN:	Approach Linearization calibration into a hardwire shunt located at the 50% point on the approach.
GD:	Gate Down, input energized when gate arm is horizontal.
GFT:	Ground Fault Tester – An optional external device connected to the Echelon LAN that constantly monitors up to two batteries for ground faults and indicates battery status to the SEAR Ili.
GP:	Gate Position – Input energized when gate is vertical.
GU:	Gate Up – Used in a user defined SEAR Ili application program, (the same as GP).
Highway-Railroad Grade Crossing Advance Warning Sign:	A traffic control sign (round yellow sign with RR and a black X) placed by the highway agency in advance of many highway-railroad grade crossings
Healthy:	The GCP system, modules and track circuit are operating as intended. Health is generally indicated by a yellow LED flashing at 1 Hz (approximately the same flash rate as the FLASH SYNC on a controller or a flashing light signal). Unhealthy conditions are indicated by faster flash rates (2 Hz and 4 Hz) or a dark Health LED.
Hz:	Hertz – Common reference for cycles per second or flashes per second.
iLOD:	Intelligent Light Out Detector – used for measuring lamp current.
Interconnection:	The electrical connection between the railroad active warning system and the traffic signal controller for the purpose of preemption.
IO or I/O:	Input/Output
ISL:	Island
ISL CAL:	Island calibration
kHz:	Kilohertz – 1000 Hz or 1000 cycles per second.
LAMP 1 VOLTAGE:	Voltage on 1L1 or 2L1 lamp output of the crossing controller module, SSCC Ilii.
LAMP 2 VOLTAGE:	Voltage on the lamp 1L2 or 2L2 lamp output of the crossing controller module, SSCC Ilii.

GLOSSARY

LAN:	Local Area Network – A limited network where the data transfer medium is generally wires or cable.
Linearization:	The linearization procedure compensates for lumped loads in the GCP approach that affects the linearity (slope) of EZ over the length of the approach.
Linearization Steps:	A calibration value that allows the GCP to compensate for non-linear EZ values within the approach circuit.
LOS:	Loss of Shunt – Commonly due to rust and / or rail contamination. LOS timers provide a pick up delay function.
Lumped Load:	A section of track that has a lower ballast resistance than the rest of the approach because of switches, crossings, contamination, etc.
MAIN:	The primary GCP Modules (CPU, Track, and RIO Modules) that are in a dual GCP chassis.
MBT:	Abbreviation for Master Boot file
MCF:	Module Configuration File – The GCP application logic file.
MEF:	Module Executable File – The GCP executive software program.
MS:	Motion Sensor – A train detection device used as part of a highway-railroad grade crossing warning system to provide a detection of a train approach.
MTSS:	Mini Trackside Sensor – A device located in the gate mechanism that combines input information from gate contacts, bell, and gate tip sensor and sends the information to the SEAR II.
NEAR GATE:	On the same surge panel, the 'near gate' is the flashing light signal or gate with the lowest voltage drop in the cable circuit. In general, if both signals have the same number and type of lamps and the same size cable conductors, the 'near gate' is the location with the shortest cable run. The 'near gate' circuit on the surge panel has an adjustable resistor in series with L1 and L2 that provides additional voltage adjustment.
OCCN:	Office Configuration Check Number – The 32 bit CRC of the configuration data, excluding items that are protected by the Maintainer Password.
OCE:	Office Configuration Editor – The PC version of the DT that can be used to create configuration package files (Pac files) for the Model 5000 GCP system.
Offset Distance:	The distance between the track circuit connections of the remote GCP (sending DAX information) to the island track connections of the UAX GCP (receiving the information).
Out Of Service:	The process for taking one or more GCP approach circuits and / or approach and island circuits out of service.
PAC File:	A Model 5000 GCP configuration Package File that can either be created in the office using the OCE, or downloaded from a Model 5000 GCP system via the CP.

GLOSSARY

Pick Up Delay:	An internal delay time between when an input receives the signal to pickup and when it actually responds.
POK:	Power Off Indication
Positive Start:	Activate crossing devices when EZ level is less than a programmed value.
Preemption:	The transfer of normal operation of traffic signals to a special control mode.
PRIME:	The PRIME predictor is usually the main predictor that controls a crossing.
VITAL COMMS:	DAX information transmitted via Spread Spectrum Radio or other communications devices.
RIO:	Relay Input Output Module
RS232:	Industry standard serial port.
RTU:	Remote Telemetry Unit
RX:	Receive
SEAR Application Program:	Programming for SEAR III that controls alarms.
Simultaneous Preemption:	Notification of an approaching train is forwarded to the highway traffic signal controller unit or assembly and railroad active warning devices at the same time.
SIN:	Site (Subnode) Identification Number - A twelve-digit ATCS address representing the module as a subnode on the network.
Spread Spectrum:	A method of radio transmission in which the transmitted energy is evenly spread over the complete bandwidth of the radio, resulting in a low RF profile.
SSCC:	Solid State Crossing Controller
SPI ECD	Serial Peripheral Interface External Configuration Device – A serial EEPROM (Flash Memory) device mounted inside the chassis of the GCP unit. This ECD is used to store site-specific configuration data (MCF, SIN, and configuration parameters) for the CPU.
SSR:	Spread Spectrum Radio – A radio that utilizes spread spectrum transmission.
Standby:	The GCP Backup Modules (e.g., CPU, Track, and RIO modules) that are in a dual GCP chassis.
Supervisor Password	The password set that allows application design personnel access to office editable parameters.
TCN	Track Check Number (TCN) is used to track changes due to re-calibration and adjustments made to key Track Modules specific setup variables.
True RMS AC+DC:	A scale on a multimeter that measures the effective combined AC and DC portions of the total voltage. Used to measure the pulsed output of a crossing controller.
TX:	Transmit
UAX:	Acronym for Upstream Adjacent Crossing (Xing). UAX inputs are used to receive prediction information from an upstream GCP as inputs to a downstream GCP when insulated joints are in the approach circuit.

GLOSSARY

USB ECD	Universal Serial Bus External Configuration Device – A universal serial bus device mounted inside the chassis of the GCP behind the display module. This ECD is used to store log data and SEAR Ili Configuration data.
USB Port:	Universal Serial Bus Port
USB Drive:	A memory device that plugs into a USB port which is commonly called flash drive or memory stick.
VHF Communicator:	Communications device used for remote operations and calibration as well as data communications.
VLP:	Vital Logic Processor – One of two microprocessors on the CPU module, processes GCP vital system logic.
WAMS:	Wayside Alarm Management System – An office based application that communicates with and receives data from specially equipped crossings.
Wrap:	Common reference for a track circuit, or combination of track circuits that extend to or beyond the limits of a GCP approach, which provides train detection. Used to signify that a certain system function is being overridden based upon the state of a vital input.
Z Level:	An Island calibration value. A calibrated island will have a nominal Z Level of approximately 250. The Z Level approaches 0 when shunted.

SIEMENS

Siemens Mobility, Inc.,
700 East Waterfront Drive
Pittsburgh, Pennsylvania 15217
(800) 626-2710

Siemens Mobility, Inc.,
939 S. Main Street
Marion, Kentucky 42064
(800) 626-2710

Siemens Mobility, Inc.
2400 Nelson Miller Parkway
Louisville, Kentucky 40223
(502) 618-8800