



SIEMENS

Ingenuity for life

MineralsFocus

The Magazine for the Mining
and Cement Industries

Issue 2019

siemens.com/mining | siemens.com/cement

Contents



04 Digitalization on the rise in minerals operations



14 Repeat customers turn to Siemens

03 Editorial | 28 Credits

Cover story

- 04 Digitalization: A paradigm shift in minerals**
More and more companies all over the world are turning to digital integration to increase efficiency and save money.
- 10 Solutions for security by design**
Securing automation and IT systems against cyberattacks and manipulation is a top priority in almost every plant and project.

Mining

- 12 The gold standard of customer loyalty**
Since February 2018, TUMAD Mining Inc has been profiting from state-of-the-art electrical and automation technology from Siemens Turkey.
- 14 Leading the gearless mill drives market**
Copper mines in Russia, Peru and Chile have recently placed orders for technology from Siemens.
- 16 Setting the highest safety standards**
Among the first to benefit from an update for the Winder Technological Controller from Siemens is the world's largest polyhalite mine.
- 17 Optimum load distribution**
A new plug-and-play controller extends Siemens' mining portfolio.

- 18 Fast power**
Mining and cement companies are set to benefit from fast-track power plants based on mobile gas-turbine technology.
- 20 Service goes digital**
Reactive service calls and maintenance according to plan are being replaced with service technologies that employ digital tools.

Cement

- 22 Industry standard grows with the times**
For over 40 years, Cemat has been helping the cement, mining and related industries to keep production costs competitive and comply with regulations.
- 24 For higher availability and efficiency**
In an interview, Ömer Oydaşık, Head of Cement at Siemens, talks about the different digital solutions Siemens has on offer for the cement industry.
- 26 Bigger and better**
An extensive modernization project has allowed a cement company in Texas to improve plant safety and increase production, energy efficiency and availability.

Dear readers,

Who wouldn't want greater productivity, flexibility and efficiency in their minerals operations? In the last issues of our magazine, we showed you how digitalization can offer just that. In this issue, we go into depth on how digital solutions are being integrated into minerals operations today.



On the one hand, the Siemens digital portfolio focuses on the big picture. For example, for Mintal Group Ferrochrome Science and Technology Co. Ltd., we are designing, engineering and commissioning a new production management system based on our Minerals Operation Management Solution. The system will draw data from all information sources already in place. While one advantage is that communications silos will be eliminated, the even greater benefit comes from the business-level insights that can be drawn from the data.

On the other hand, our digital portfolio addresses individual systems. A case in point is stockyard management. In China, environmental regulations now call for all newly constructed stockyards to be indoors. With their high temperatures and even higher levels of dust, we're seeing an increased need for autonomous storage and retrieval machinery – which are only possible with digitalization. Another example of an individual system that is being increasingly digitalized is belt conveyors. Through our collaboration with MineSense, we are now able to offer the real-time measurement of ore grades and the characteristics of bulk materials.

Digital solutions are becoming well established in minerals, and we are constantly looking at further areas to digitalize. An example here is our work on a cloud concept for mine hoists to among others monitor machine status and service routines. As you can see, there is no standing still.

I hope you enjoy reading about how Siemens is driving digitalization and veritably causing a paradigm shift in minerals industries. But even more, I look forward to accompanying you, our customers, as you continue your digital journey.

Best regards,

A handwritten signature in black ink that reads "Roland Ehrl". The signature is written in a cursive, flowing style.

Roland Ehrl
Minerals Executive Vice President
Siemens AG

Digitalization: A paradigm shift in minerals

More and more companies all over the world are turning to digital integration to increase efficiency and save money. In minerals operations, these digital solutions cover individual aspects all the way up to entire operations.



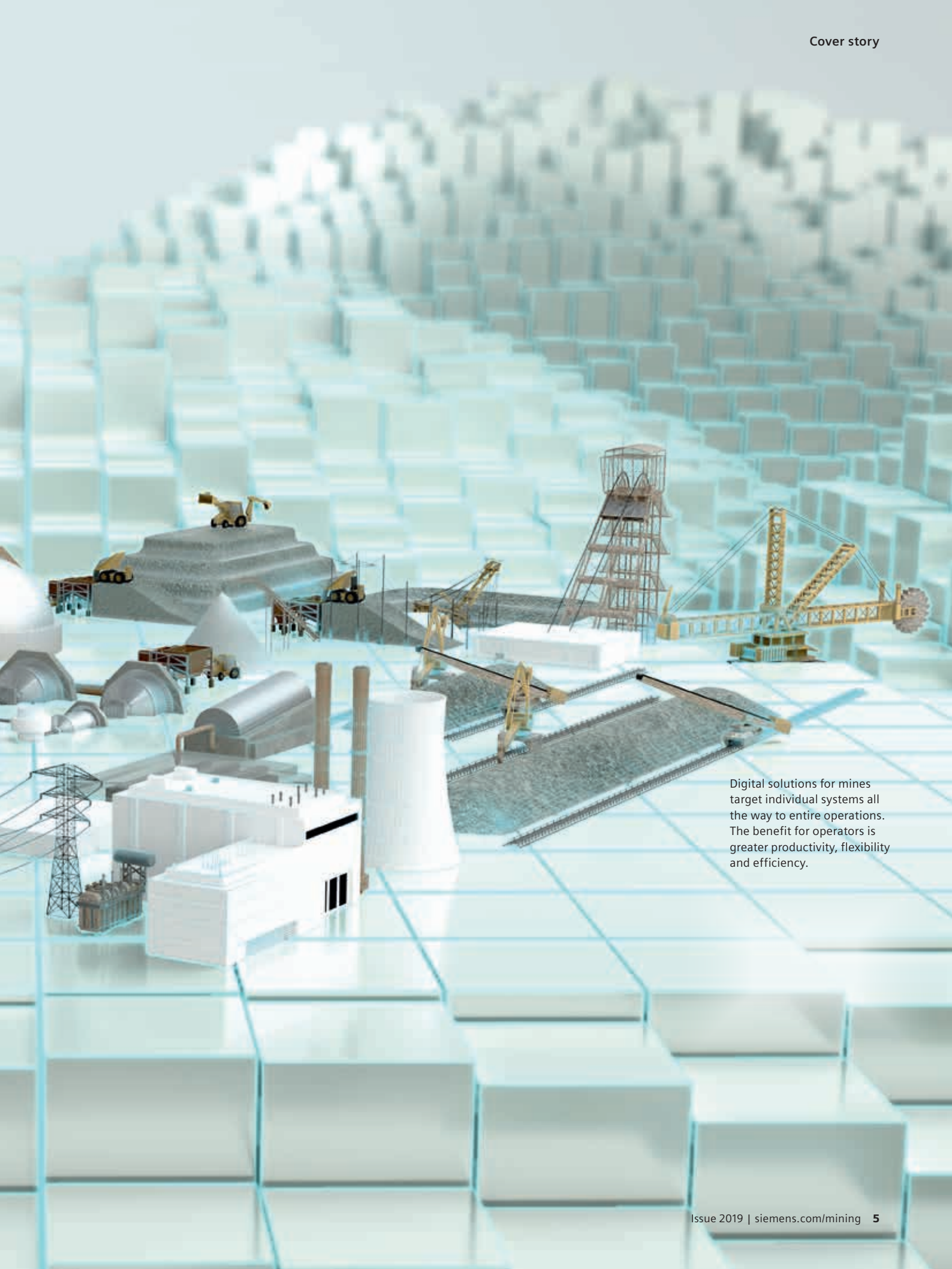

Digital solutions for mines target individual systems all the way to entire operations. The benefit for operators is greater productivity, flexibility and efficiency.

Siemens is on the constant lookout for solutions to further develop its portfolio to help mining companies competitively fulfill customer demands.

In today's world, mining companies have their work cut out for them as they face declining ore grades, safety concerns, environmental protection regulations and volatile prices. Cutting-edge solutions are the way forward, and that means integration of more and more digital technologies. While digital solutions have been around for quite some time, Siemens is noticing a big uptake among mining customers across the globe. Increasingly, these digital solutions are being integrated with the goal of alleviating cost pressure.

In a recently won project, for example, Siemens will help eliminate information silos at Mintal Group Ferrochrome Science and Technology Co. Ltd., the largest chrome alloy manufacturer in China. The key task in the project is to close the often-significant information gap regarding production planning, quality, production execution and material logistics that can exist between customer enterprise resource planning (ERP) and plant automation systems. For this, Siemens will design, engineer and commission a new production management system (PMS) based on the Siemens Minerals Operation Management Solution. With technology-based services throughout the life cycle of an industrial plant, Siemens provides the basis for greater productivity, flexibility and efficiency – reliably, globally and around the clock.

Mintal will benefit from more unified planning and business-level insights based on integrated, current and actionable data drawn from its information system, from ERP and that of other business functions, and from its plant automation, which is based on Siemens Simatic PCS 7. The new PMS provides a fast and powerful solution for improving the product manufacturing experience and production management. Featuring the framework and functionality of Minerals Operation Management Solution, it is optimized for the production-process characteristics of chrome ore pellets and high-carbon ferrochrome. The collaborative management of equipment, personnel, materials and other resources enables Mintal to achieve a complete picture of production scheduling and control, equipment operation and maintenance cycle management, and material and production quality control.

Safer and more efficient loading and unloading

Digitalization is helping Mintal with the big picture. Yet digitalization also plays a role in individual systems, such as the autonomous stockyard management system Siemens is supplying to HBIS Laoting Steel Co. Ltd., a Chinese subsidiary of one of the world's biggest iron and steel producers. The system comprises a material tracking and management system (MAQ), an autonomous stockyard operating system (MOM), a Simatic PCS 7 process control system and an industrial network. Consulting, engineering, project management and commissioning are also part of the project. Interaction between these different components enables control of all the plant's machines and conveying technology. In addition, it offers wide-ranging benefits, such as the capability for all machines and conveyors to be controlled from a single system.

The new systems will allow HBIS Laoting Steel Co. Ltd. to not only drive down its operating costs, but also achieve a 5 to 10 percent improvement in system efficiency and to increase production capacity by 3 to 7 percent. The use of autonomous storage and retrieval machinery also improves safety, as no operators are needed at the machinery. In addition, the mechanical parts of the equipment are exposed to less wear and tear.

What prompted HBIS Laoting Steel Co. Ltd. to look at using an autonomous stockyard management system from Siemens was new environmental regulations set down by the Chinese government. The regulations require all newly constructed stockyards to be indoors. The high temperatures and levels of dust involved make for harsh working conditions, meaning that only autonomous storage and retrieval machinery can be operated in these new indoor facilities.

Jiangsu Binxin Special Steel Material Co. Ltd. (Binxin Steel) is also responding to these new regulations by moving its stockyards indoors. At the same time, Binxin Steel has also decided to upgrade its plant intelligence with Siemens' autonomous stockyard management technology. The solution will do more than fulfill environmental requirements; it will allow Binxin Steel to achieve higher performance, increase accuracy, fully utilize the

stockyard area, and optimize energy consumption compared to staffed operation.

A core element of the autonomous stockyard management systems like those at HBIS Laoting Steel Co. Ltd. and Binxin Steel is the stockyard 3D model. It provides information on the volume and quality of stocked material, and it enables autonomous operation of all the plant's storage and retrieval machines. The model is updated regularly with data delivered by stackers and reclaimers. After the working area and the parameters for each job are specified, the details are calculated automatically and approved by the control center. The job is then transferred to the machines, and the rest is automatic. To prevent collisions between machines and other objects and constructions, the stockyard machinery comes with a protection system that relies on data delivered by sensors.

More intelligence for belt conveyors

In an environment in which it is becoming increasingly difficult for mining companies to competitively fulfill customer demands, Siemens is on the constant lookout for solutions to further develop its conveyor portfolio. To this end, Siemens is collaborating with MineSense on the

real-time measurement of ore grade and ore characteristics for conveyors. MineSense, a British Columbia-based company, is a pioneer in industrial IoT providing real-time, sensor-based ore data and sorting solutions for large-scale mines. The company's fast, scalable and robust mineral-sensing platform creates transformational value by providing precise, accurate, real-time grade control and ore routing decisions at the point of extraction for maximum resource conversion and metal recovery. The results are reduced CO₂ emissions, water consumption, wear materials, energy, water and reagents during the whole mining process.

For the joint solution, each company is bringing its strengths to the table. The resulting solution will for the first time provide real-time measurement of ore grades and byproducts by MineSense's BeltSense™ in combination with Siemens' MAQ. This new and comprehensive approach will enable operators to significantly increase efficiency via a single view of quality across the whole conveying process.

Knowing before it's too late

Equipment like belt conveyors or grinding mills is operated around the clock. It is essential that it functions without fail, because unexpected downtime can carry a

In the mine of the future, digitalization touches every aspect.

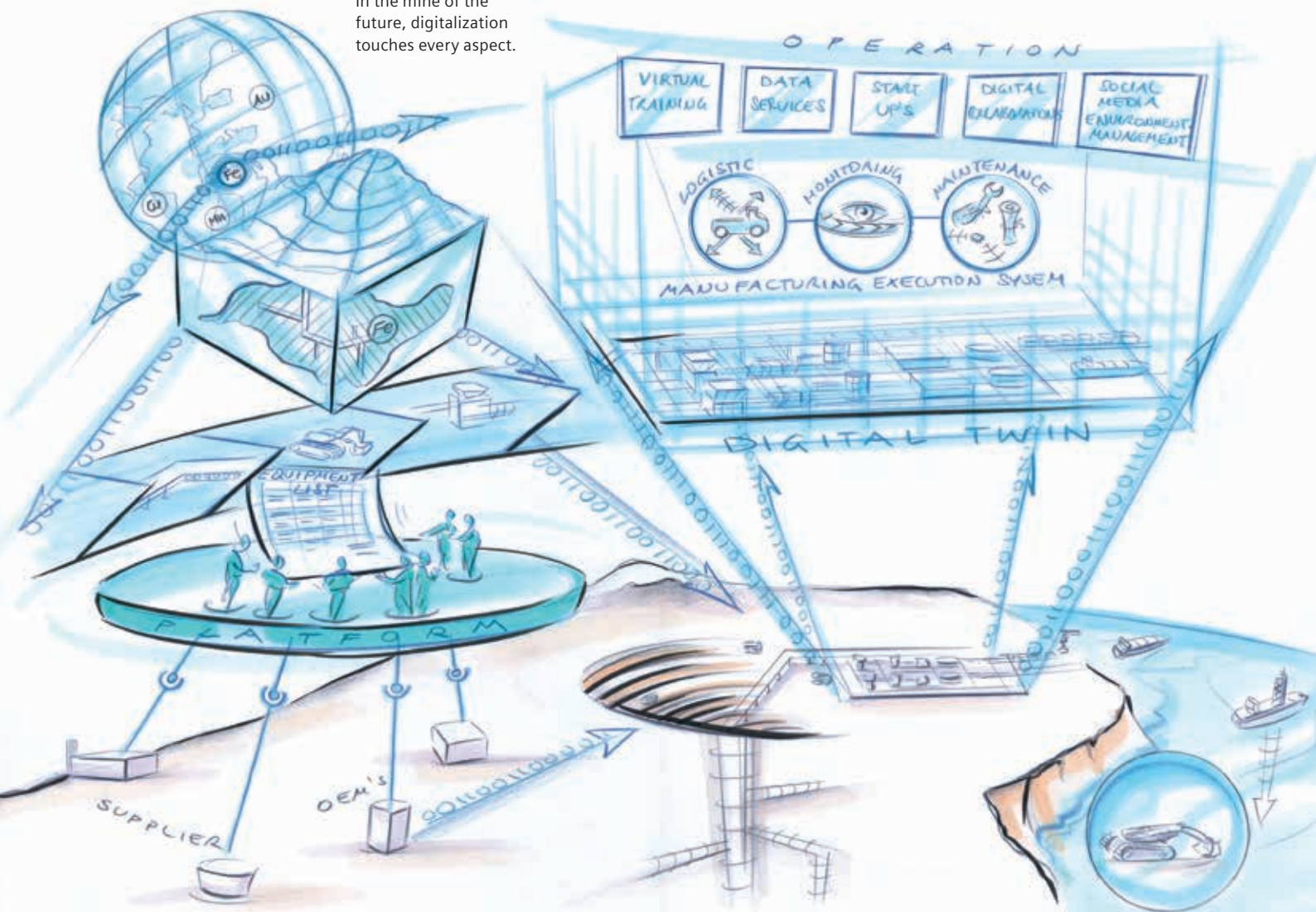



Siemens' digital portfolio combines a deep understanding of mining processes with state-of-art electric, automation and IT solutions.

Siemens will soon introduce the cloud-based platform SmartMining to detect and rectify anomalies early on.

price tag in the millions. This is where predictive maintenance comes in. Process and operational data are collected via sensors on motors and other essential equipment. Thanks to intelligent analysis using algorithms, it's possible to predict the optimal time for machine and plant component maintenance. With this information, maintenance activities can be scheduled to keep shut-downs as short as possible or to avoid them altogether.

Siemens will soon introduce the cloud-based platform SmartMining. With it, anomalies in grinding mills, belt conveyors, mine hoists and more can be detected and rectified early. Downtime is thereby minimized while the maintenance plan is optimized. The solution offers just what customers want: For the creation of SmartMining, extensive interviews were held with mining staff all over the world, including maintenance engineers and operation managers, to learn more about their pain points. Using the latest digital tools and technologies, Siemens is able to mitigate these pain points. The experience gained during the pilot phase in a mine operation on the North American continent is permanently enriching the SmartMining platform with new functionalities and technologies, such as artificial intelligence.

A strong focus is on prescriptive maintenance. For this, problems and root causes related to a specific operational point or state are identified, and then actions are prescribed with the goal to shorten or avoid unplanned downtime. SmartMining also includes the powerful Asset Health Analytics, part of which is a dashboard suite that intuitively shows the operator the status of the assessed equipment. In case an anomaly is detected – for example an evolving abnormal operational status, a so-called looming incident – a warning is issued immediately along with possible countermeasures selected from the embedded database.

More uptime

Cloud technology also figures prominently in a digitalization project at a Chinese coal mine. To increase output while reducing shutdown times, the customer is for the first time establishing an enterprise cloud concept for mine hoists. The concept will enable the customer to centrally monitor production, and to analyze and respond to insights from real-time data. Drawing on Siemens'

longstanding expertise in the mining industry and Industry 4.0, the solution will be based on the advanced design and performance of Siemens WinCC Open Architecture. As part of the contract, Siemens will also provide inter-process communication (IPC) and accessories, plus software engineering and site-commissioning services.

The project is set to begin this year, initially drawing data from four mine hoist systems at one of the customer's coal mines. To benefit from enterprise-wide insights, the mine owner intends to later extend the concept to cover up to 20 mine hoists located hundreds of miles apart from one another at different coal mines. For 24/7 transparency, the cloud platform can be accessed by users on local PCs in the enterprise network, or with remote PC or smartphones/tablets via the Internet. As a result, engineers and managers are able to monitor machine status, trace faults by historical trend, and manage service routines and the knowledge library – any time and from anywhere.

The journey continues

As the examples above show, digital solutions are becoming well established in day-to-day mining operations. More and more mines and mining areas are set to optimize their operations. What just a few years ago seemed like a futuristic scenario is now reality. Behind Siemens' digital portfolio, and what sets the company apart from the competition, is the combination of deep understanding of mining processes with state-of-the-art electric, automation and IT solutions. ■

➤ www.siemens.com/mining

Authors: Christian Dirscherl, Dan Fodor, Yun Zeng

christian.dirscherl@siemens.com

dan.fodor@siemens.com

zeng.yun@siemens.com

Solutions for security by design

Securing automation and IT systems against cyberattacks and manipulation is a top priority in almost every plant and project. However, many operators lack the required expertise to identify risks and threats. The good news: suitable solutions are now available that can be easily adapted to the individual project requirements to provide optimum security.

What happened with the WannaCry ransomware, as drastic as the effects were, was but a warning shot to plant operators and systems integrators: The worldwide cyberattack is estimated to have affected more than 10,000 organizations and some 200,000 computers across 150 countries. Especially troubling to IT and security experts is that the crypto worm used a known exploit that could have been closed with patches. However, many organizations had not applied them or were running legacy systems that could no longer be patched.

A serious reminder of a serious issue

WannaCry is just one example of a growing number of cyberattacks – and while malware that specifically targets industrial control systems is still rare, automation and control systems are already more networked with general IT systems than many plant operators realize. Having good, regular and secure backups, using appropriate software, implementing good cybersecurity including isolating critical systems, and always having the latest security patches installed should be a given.

In its whitepaper on cybersecurity, the ARC Advisory Group lists several barriers to improving cybersecurity in industrial environments. They include increasingly open industrial automation, insufficient awareness among end-user management, increased use of commercial off-the-shelf IT solutions, inadequately trained staff, and misconceptions concerning the cybersecurity life cycle.

ARC believes organizations are reluctant to act on potential threats and to adopt security planning and implementation because the task appears too daunting. Furthermore, in the customized control environment of an industrial site, it is difficult to predict how a newly introduced patch will impact the functioning of the control system, especially if the patch is not tested rigorously.

Industrial security as specified in recent guidelines, such as the IEC 62443, should therefore be treated as a life cycle concern consisting of five phases: product or system development, specification, integration & commissioning, operations & maintenance, and decommissioning.

The phases require clear accountability and coordinated communication between different roles and stakeholders such as system integrators, product suppliers and asset owners.

A blueprint for securing assets and systems

A defense-in-depth security approach covering a heterogeneous and broad range of security topics – including network security, user authentication, secure configuration and the hardening of operating system, logging, encryption, and secure channels – is required. Technical solutions and tools are available, but project teams often lack the time and expertise to choose a suitable solution for each security topic. Hence, a common pitfall is to focus on some topics in detail while overlooking others.

In November 2018, Siemens became the first company in the world to gain TÜV certification for the secure system integration of process automation and drives systems in compliance with the international IEC 62443-2-4 standards. Based on this standard, Siemens has developed several blueprints for automation and control

Defense in depth

Security threats demand action



The industrial security defense-in-depth concept from Siemens.

systems engineering to facilitate security engineering and eliminate potential security weak spots. These blueprints provide guidance in the form of references to specific resources and make sure that the engineering project produces all security documents. For example, the Siemens minerals solution blueprints for conventional mill drives and gearless mill drives have been developed according to these blueprints.

In the end, designs that fulfill IEC 62443 simplify information exchanges between stakeholders and deliver a complete set of documents for acceptance tests and the security solution certification.

Security through expertise

The development of the secure framework and the secure project blueprints was driven by Siemens' own experience. Key areas of importance include helping the asset owner identify critical assets and specify suitable protection goals; supporting the security life cycle process through an efficient threat and risk analysis; implementing efficient and effective testing and

compiling; and providing the required documentation.

Particularly in large projects where security affects different disciplines – such as network, software applications and firmware – the framework establishes a common language for engineers to work together on security. On an organizational level, the framework also facilitates the communication between units that develop components and those that work as system integrators and on service.

The security framework combines the expertise of Siemens security engineers and incorporates them into a reproducible process that yields reproducible results – thus mitigating project risks. As the blueprints are based on a comprehensive Simatic PCS 7 security standard, the secure solution can be easily designed to cover all required assets and security levels. Plant operators benefit by having a security solution engineered for their specific requirements that is ready for certification according to IEC 62443. During plant operation, the security documents support system maintenance.

As cyberthreats become more frequent and more creative, industry players are developing and deploying more sophisticated cybersecurity systems and procedures to meet ever-changing requirements. Supported by their own specialist organizations, a global network of experts for automation and cybersecurity monitors current and developing threats, analyses solutions for weaknesses, and develops suitable measures, thus making sure that their control and automation solutions are and continue to be secure by design. ■

➤ www.siemens.com/mining
Author: Ormond O'Neill
ormond.oneill@siemens.com

The gold standard of customer loyalty

Since February 2018, TUMAD Mining Inc has been profiting from state-of-the-art electrical and automation technology from Siemens Turkey for its Lapseki mine in Turkey's Çanakkale province. TUMAD has been satisfied with the turnkey solution – so much so that the company has decided to work with Siemens Turkey on an upcoming project.



1 Working hand in hand: the Siemens Turkey and TUMAD Mining Inc teams take time for a group photo during the construction period that lasted from May 2017 to May 2018.

2 Turkey's mining industry is active in all steps of the gold value chain – from exploration and mining all the way to refining and preparing the precious metal for different end uses.

Coins and jewelry, works of art, and even electronic components: the list could go on and on for the many uses of gold. According to the World Gold Council, demand for the material is growing. In fact, the amount of gold purchased annually has quadrupled since the early 1970s. To fulfill the rising needs, today gold is mined on every continent except Antarctica. Whereas around four decades ago the majority of supply came from South Africa, production is now evenly distributed worldwide.

An up-and-coming producer is Turkey. Research shows that the country has reserves of up to 6,500 tons, which make up for as much as an eighth of globally proven reserves. When it comes to gold production, Turkey's mining industry is active in all steps of the value chain – from exploration and mining all the way to refining and preparing the precious metal for different end uses.

One of Turkey's more recent projects involving gold has been the opening of the Lapseki mine in the Çanakkale province, operated by TUMAD Mining Inc. Over the entire operation period, which is expected to extend to 2027, the mine's four pits are estimated to produce a total of 7.15 million tons of ore. The proportions of gold and silver per ton are 1.85 grams and 1.86 grams, respectively. The production cycle

boasts a recovery rate of 94.91 percent for gold and 72.35 percent for silver.

Proven experience

With dimensions like these, one thing is clear: operations have to be dependable and economical. So when it came time to select a solution provider for the mine, TUMAD turned to Siemens Turkey, the country's market leader for electrical and automation technology for minerals works. "With our high level of expert knowledge for turnkey projects, expansions, conversions and modernizations, we turned out to be an excellent partner for the Lapseki mine," says Emrah Mehmetogullari, Account Manager for Minerals at Siemens Turkey. Extremely valuable was the fact that the Siemens engineers were able to draw on their experience with other mining projects in the country.

The range of services supplied to TUMAD for the Lapseki mine covered the delivery and installation of electrical equipment and integrated solutions including design, planning, engineering, project management, manufacturing, installation, testing and commissioning on a turnkey basis. "As many local facilities as possible and fully local resources were involved in the project," notes Mehmetogullari.

Among the scope of delivery is three control rooms – one each for the mill, the crusher, and the adsorption,

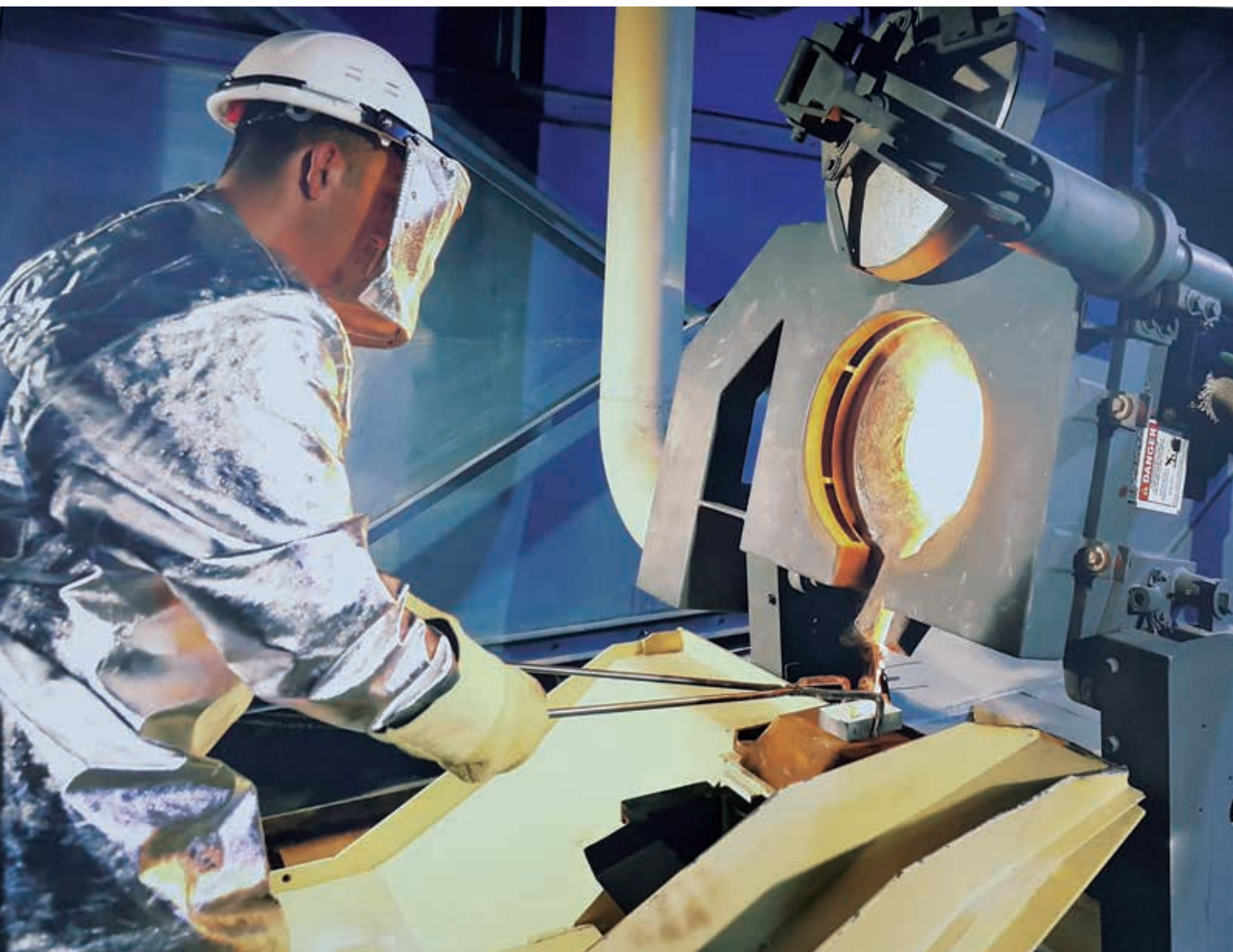

The excavated gold is further processed at the Lapseki mine. Here the ADR gold and silver ore process.

desorption and refining (ADR) plant – and five electrical rooms – for the crusher, mill, leach, ADR plant and filter press. The automation system at the Lapseki mine is made up of two redundant OS servers, three clients, a web server, three engineering stations and four CPU 410s. The equipment processes 2,300 hardwired signals and a total of 4,000 signals communicating with third-party systems. For the process control system, TUMAD selected Cemmat MinAS, which is based on Simatic PCS 7, the most proven distributed control system in the world. Cemmat MinAS delivers everything necessary to seamlessly meet the most relevant demands of

About TUMAD Mining Inc

TUMAD Mining Inc – a Turkish mining company that holds its own mineral exploration licenses – carries out exploration and development projects for precious and base metals. The company's strategy is to create large efficient mine production sites that unite economic and social development interests with environmental protection and worker safety.

the industry: productivity, plant availability and energy efficiency are covered, and for end users the system is easy to configure and use.

Collaboration continues

Since the Lapseki mine was commissioned in February 2018, staff members at TUMAD have been able to depend on the technology from Siemens to help them get their jobs done. In fact,

the satisfaction level is so high that TUMAD has again decided to work with Siemens Turkey on a turnkey basis for its Balıkesir-İvrindi gold and silver mine processing project in western Turkey. ■

➤ www.siemens.com/mining

Author: Emrah Mehmetogullari
emrah.mehmetogullari@siemens.com



Leading the gearless mill drives market

Copper mines in Russia, Peru and Chile have recently placed orders for technology from Siemens. Most of these orders are from customers who already have Siemens technology at their sites – customers who have come to depend on the availability and reliability of Siemens' gearless mill drive solutions.

Copper is an indispensable basic material for many sectors of the world economy. Demand continues to grow, driven by the increase in the production of components for power grids and transmission systems, the emergence of electric vehicles, a strong market for consumer electronics like smartphones and tablets, the building boom in many parts of the world, and the continuous need for modern industrial machinery.

For 2019, analysts expect total global demand to increase by around 4 percent. To fulfill growing needs, the recovery of non-ferrous metal continues at a high rate. On the one hand, mine owners are taking steps to expand their operations. And on the other hand, new greenfield processing plants are once again being built to process the higher volumes of extracted ore. These developments, particularly the latter, are behind contracts Siemens has received for gearless mill drives for mines in Russia, Peru and Chile. In most cases the clients are repeat customers who have come to depend on the extreme reliability, high availability, minimized unscheduled downtimes and low operating costs of Siemens' gearless mill drives.

For a copper mining project in Russia – one of the most extensive in recent years – Siemens is supplying six gearless drive systems for two semi-autogenous grinding (SAG) mills with a required power of 23 MW each and for four ball mills with a power demand of 22 MW each. Alongside the ring motor, each of the drive systems features three converter transformers, one Sinamics SL150 medium-voltage converter, and a Simatic PCS 7 process control system unit for control and monitoring of the mill.

Partner from day one

For one of the projects in Peru, a new gearless mill drive with an output of 16.4 MW and a diameter of 26 feet complements the four gearless mill drives already in place at the mine. In fact, from day one the individual production lines in this Peruvian plant have largely relied on components from Siemens, as each mill at the site is equipped with a gearless

Asset Health Analytics further enhances the “best-in-class” availability.

mill drive. Additional materials have included the matching transformers, safety equipment, e-houses, cooling systems and various operating elements. Both the mills and drives are monitored by the integrated Simatic PCS 7 process control system.

Another major greenfield project in Peru features two SAG mills, each measuring 40 feet in diameter with an output of 23.5 MW, and two 28-foot ball mills also with an output of 23.5 MW each. With this machinery in place, the mine is set to become one of the country's biggest copper producers. In any case, both projects together help to strengthen Peru's position as the second-biggest copper-producing country worldwide.

Expanding capacities

Chile, the top copper-producing country in the world, is also starting to once again expand capacities now that the previous overcapacities are being fully utilized thanks to the increasing market demand. Currently, Siemens is delivering to a mine site in the Atacama Desert an order for one SAG mill with a diameter of 30 feet and an output of 28 MW, and for two ball mills each with a diameter of 27 feet and an output of 20 MW. The next project milestone is construction and commissioning.

A further Chilean mine is also expanding – and in this case the customer is again profiting from Siemens' expertise: a 38-foot, 20 MW SAG mill and a 25-foot, 12 MW ball mill will soon

be constructed at an existing mine. For many years, four ring motors from Siemens have been reliably operating at the site.

In all of the projects described above, the equipment has been designed and constructed for easy integration into the Siemens digital environment. And in some cases, upon the request of the customers, the gearless mill drive systems include comprehensive Assets Health Analytics to further improve performance and availability. Behind services like these is MindSphere, the cloud-based, open IoT operating system from Siemens.

What's more, the projects represent a total of 16 gearless mill drive orders consisting of fabrication, delivery and commissioning for multiple global mining sites since 2018. As a result, Siemens is helping copper mines to ramp up production and take advantage of current market trends, and that allows them to keep the world's copper supplies in pace with growing demand. The projects described here and the many other orders Siemens has fulfilled for copper producers put the company in an industry-leading position for gearless mill drive systems. ■

➤ www.siemens.com/mining

Author: Felipe Contreras
contreras.felipe@siemens.com



New greenfield processing plants are once again being built to process higher volumes of extracted ore.

Setting the highest safety standards

An update for the Winder Technological Controller from Siemens has made winders safer than ever before. Among the first to benefit from the improved technology is the world's largest polyhalite mine.

Safety integrity level (SIL)

SIL is a method for determining potential risk to life and limb as well as to systems, devices and processes in the event of a malfunction. The rating method is based on the International Electrotechnical Commission standard IEC 61508.



Siemens has launched an update to its mine winder portfolio. On the one hand, it brings its Winder Technological Controller (WTC) fully in line with the latest digitalization standards using the Simatic S7-1500 digitalization platform. And on the other hand, it ensures the solution adheres to safety integrity level (SIL) 3. In fact, Siemens is the first company worldwide to integrate this safety standard in a mine hoist. The new controllers are compliant with most international safety standards, including the German TAS and the Chinese MA. The safety system is used primarily for speed and position monitoring, depending on the operating mode and conveyance position in the shaft.

Additional functions of the WTC include the continuous acquisition and collection of motor, converter, brake system and mine winder data. The accumulated data is then downloaded to one of the Siemens Winder Competence Centers and analyzed as the basis for recommended preventive maintenance. Among the first installations to benefit from the new WTC is the Woodsmith polyhalite mine in the UK.

An extensive package

Polyhalite is a nutrient-based fertilizer. From 2021, the Woodsmith mine run by Sirius Minerals will be the world's largest polyhalite producer. OLKO-Maschinentchnik GmbH, which is supplying two Blair Multi-Rope machines (BMR) for the mine, has ordered the electrical equipment from Siemens. One hoist will bring polyhalite from a depth of approximately 1450 meters below sea level to the surface at a speed of 18 meters per second; the other hoist with a capacity of 35 tons is for service. The scope of delivery comprises a medium-voltage synchronous motor with an output of 9.3 MW and a torque of 1550 kNm. Both winders are fitted with a COBRA01 multi-channel brake system to provide soft braking. Thanks to Siemens, mine hoists like the one at the Woodsmith mine are now more digital and safer than ever. ■

www.siemens.com/mining

Author: Roland Gebhard
roland.gebhard@siemens.com

Optimum load distribution

A new plug-and-play controller extends Siemens' mining portfolio. The first installation at a cement grinding mill in Guinea has shown significant benefits.

The Simine portfolio for high-pressure grinding mills (HPGR) has been extended to include a new Load Share Controller. Plug-and-play functionality makes it available for immediate use. The web-server-based operator interface allows the process and production engineer to adapt the controller parameters at any time – whether on- or offline – and thus optimize the torque distribution. Programming skills or special equipment knowledge is not required.

The new Load Share Controller follows the established control scheme. During start of the HPGR, the controller is inactive. When a certain torque level has been reached, it takes over load share control. If the controller is not ready for use, for example, in the event of a disruption, the drives do not start. However, operation without load sharing is available; in this case, the drives take the speed reference from the mill automation.

Successful utilization

The controller is already being used by one customer: KHD Humboldt Wedag, an OEM in the cement and mining industry, installed the controller in the framework of a grinding plant upgrade for Guinée Industries Ciments in Conakry, Guinea. Tests before and after optimization have demonstrated great benefits of the optimized controller for the mill. For example, the change in the roll gap and the roll pressure could be kept in a substantially smaller range. ■

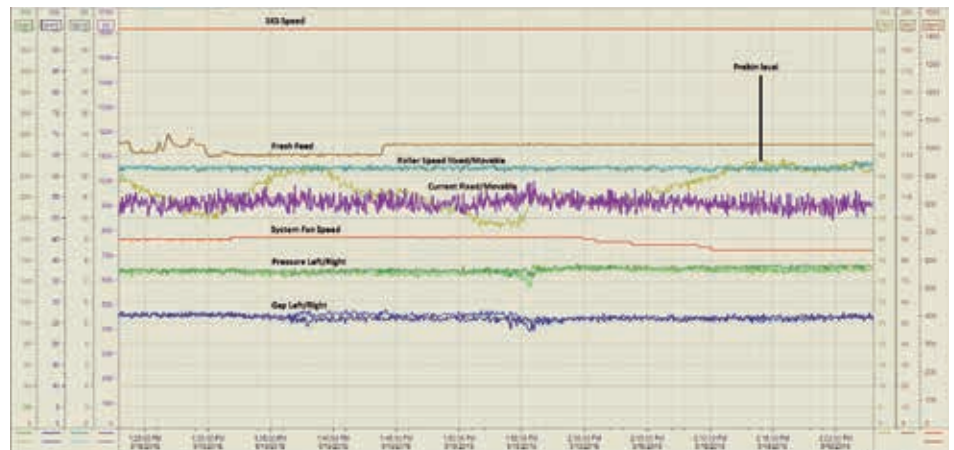

Within the first weeks after production startup, KHD Humboldt Wedag commissioned and optimized the controller without any support from a service engineer. The graphics show trends before and after load sharing.

www.siemens.com/mining-digitalization

Author: Werner Kitz

werner.kitz@siemens.com



Fast power

Over the last couple of decades several economic, environmental and technological factors have led to the expansion of distributed forms of electricity generation. One segment of this market in particular has seen a major expansion in recent years: fast-track power plants based on mobile gas-turbine technology. Mining and cement companies are set to profit.

Companies active in mining and cement need electricity – lots of it. But sometimes the electricity that powers conveyor systems, drives, lighting, control rooms and more is in short supply. One common reason is aging or unreliable infrastructure. The unplanned retirement of an outdated power plant or the loss of a reliable distribution network can cause significant unbalance in electrical grids, leading to production losses. Mining operations in remote locations often suffer from unstable electricity sources – or even the absence of a grid connection. Another common situation is when great amounts of electricity are needed on a temporary basis. This could be the case when an otherwise out-of-commission cement mill is put into operation temporarily.

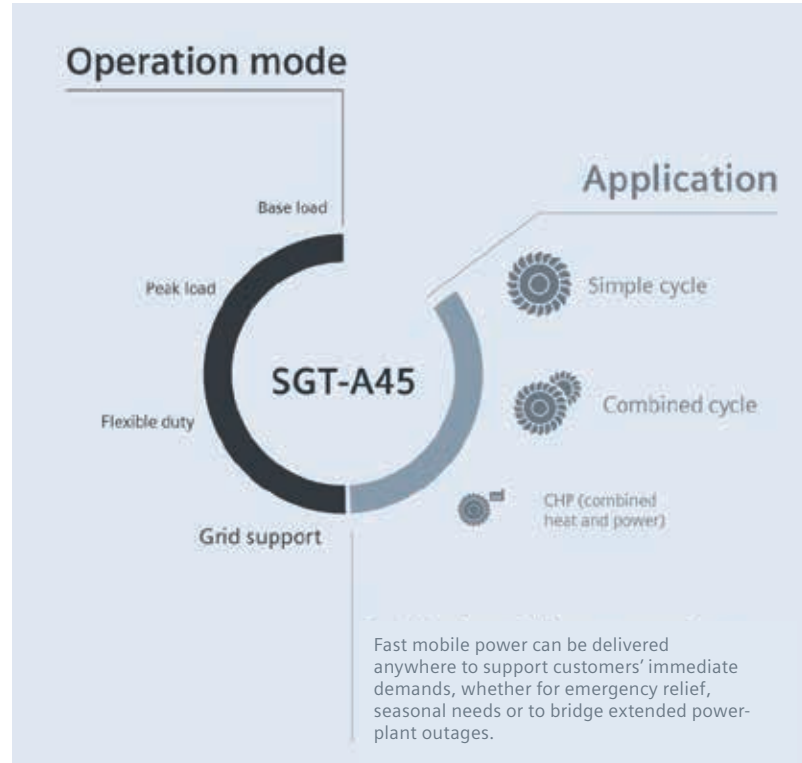

Above: Operation modes of the SGT-A45 aero-derivative gas turbine at a glance.

Left: Pre-assembled plug-and-play units mounted on trailers require minimum installation time at the site – and they can be quickly redeployed to a different location when the additional power is no longer needed.

Siemens Power & Gas provides a solution: fast-track power plants based on mobile, aero-derivative gas-turbine technology. The centerpiece of the offering is the SGT-A45.

Highly efficient and flexible

With fast-track delivery and an installation time of two weeks or less, and significantly higher power output and density than comparable products in this market, the SGT-A45 offers considerable cost-saving potential. Lending to the fast implementation time is the fact that the units are pre-assembled and mounted on trailers. A plug-and-play design allows them to be integrated into existing grids quickly. The unit's high fuel efficiency and operational flexibility ensure low operating costs

and a high level of adaptability to the requirements of mining and cement customers.

The performance advantage of the SGT-A45 mobile unit is amplified in hot climates: At 30°C and in 50 Hz operation, the SGT-A45 still retains almost all of its ISO-rated output, without any auxiliary water injection. Where water injection is used, the unit produces a near constant power output up to ambient temperatures in the proximity of 40°C. In both cases, the aero-derivative design provides the operational flexibility required by the cement and mining industries. A further advantage is the fuel type: Dual-fuel capability of natural gas and diesel is standard, with the ability to change between fuels at any load without

having to shut down or disturb operations. On request, the units can be adjusted to run on other fuels too.

And when the additional power is no longer needed? No problem: the trailer-mounted power plants can be quickly redeployed via truck or airfreight to a different location. Of course, if something more permanent is needed, Siemens Power & Gas has other solutions on offer depending on the available fuel and generation demand. ■

➤ www.siemens.com/mining

Author: Thorsten Krol
thorsten.krol@siemens.com

Service goes digital

Reactive service calls and maintenance according to plan are being replaced with service technologies that employ digital tools. Less unscheduled downtime, more precise troubleshooting and optimized maintenance schedules based on equipment condition are among the benefits.

For generations, maintenance has been based on standard schedules. And up to some extent, it works. Nonetheless, unscheduled downtimes do happen, for example when a component fails unexpectedly. Until the issue is identified and rectified, hours and even days can pass – which can easily result in losses in the millions. But it doesn't have to be that way: preventive and predictive maintenance based on digital services help keep equipment running longer because possible failure sources are identified before they can become a problem. And if something does occur, equipment can be brought up more quickly with the help of data “messaging” any anomalies upfront.

Continuous monitoring as offered with Digital Drive Train Services is based on a cloud solution and ensures constant knowledge about the condition of the components. Before critical changes can arise, certified service experts contact the user immediately, identify the fault, and provide support with troubleshooting. Users also benefit from automated status reports and notifications that allow them to detect faults at an early stage. Connected devices can be checked on the customer dashboard at any time. This allows users to consult with Siemens service experts to obtain service recommendations. If despite these measures downtime does occur, operators can react quickly by directly connecting a service expert to the plant. Condition-monitoring

services like these minimize scheduled and unscheduled downtimes thanks to optimized maintenance activities. Early planning and optimization of maintenance and service measures save a significant amount of time and money.

Fast and precise troubleshooting

An example shows the value of Digital Drive Train Services: At a customer's operations the drive train was failing during operation. Thanks to Digital Drive Train Services, the drive train was brought back into operation quickly. In this case, Siemens received information about the failure and could also refer to drive data including a fault log and event log. Historical data showed that the customer could fix the problem on its own – no need to call in field service staff. The Siemens service experts also provided support for implementing corrective steps. Through the digital-based service, 11 hours could be saved in rectifying the problem.

Digital Drive Train Services also enable long-term data analysis and trend evaluations, which serve as a basis for detailed condition assessments as well as specific service recommendations. In one instance, data collected at a customer installation showed that a bearing was about to fail as a result of inner ring damage. The bearing repair was then added to the activities for an upcoming scheduled planned downtime. By doing so, an unplanned shutdown of around eight days could be completely avoided.

Local maintenance teams receive support from Siemens Digital Services.

Digital industry services for gearless mills

The digital service isn't just for medium- and high-voltage applications, but also for gearless mill assets. In mining operations, these drives are mission critical. This key equipment, if not functioning, can cause bottlenecks that impact mine productivity, so it is essential that uptime is kept high. Thus the ability to correctly assess the condition of the drives and associated sub-assets grows in importance.

With this in mind, Siemens also provides drive train analysis for gearless mill assets. The solution takes into account the specific requirements and behavior of a gearless motor, yet also covers all components – including power and cooling equipment, drives, the mill itself and the e-house. The data





collected from sensors on the different units is preprocessed at the site and transferred to a central cloud. A customer dashboard visualizes all relevant status information. The plant operator gets details on which assets are connected, their status in regard to maintenance-specific KPIs, and an overview of certain alerts and notifications. The name of the Siemens service is Asset Health Analytics for Gearless Mills.

Continuous monitoring

Asset Health Analytics for Gearless Mills employs cloud-based algorithms and models to aid service experts in continuously monitoring the condition of the connected assets. In the case of anomalies or pattern deviations, an event analysis is initiated. If a weak spot is identified, an event notification with service recommendations is sent

to the customer, followed up with concrete support for troubleshooting and maintenance recommendations – and that really does save time.

Fewer disruptions to ongoing operations and shorter downtimes for maintenance are the direct result of Asset Health Analytics. It goes further, though: the data can also be used to optimize performance, for example with Energy Performance Contracting from Siemens. All in all, this new digital approach to plant care is making reactive maintenance calls and service according to plan a thing of the past. Welcome Service 4.0. ■

www.siemens.com/ddts
www.siemens.com/mining-digitalization

Author: Hans-Jürgen Seger
hans-juergen.seger@siemens.com

Direct benefits of Digital Drive Train Services

- Minimized unplanned downtime due to early detection of anomalies
 - Shorter unplanned downtimes thanks to faster troubleshooting
 - Improved maintenance scheduling based on better knowledge of equipment condition
-



Since 1987, different Cemat versions have been in used at the HeidelbergCement site in Schelklingen, Germany.

Industry standard grows with the times

For 45 years, Cemat has been helping the cement, mining and related industries to keep production costs competitive and comply with regulations. With each new version, innovations have been integrated in line with technical progress. For the HeidelbergCement site in Schelklingen, Germany, Cemat is a trusted companion.

The success story of Cemat, the standard software for cement plants, began in 1974. The initial release was based on the then newly developed Simatic S3 programmable logic controller, and the industry's first installation was in Cementos Hispania's site in Yeles, Spain. Over the course of time, the hardware and software platforms were subsequently replaced with Simatic S5 and Simatic S7 programmable logic controllers, in line with technological advancements. The standard modules for actuators, dampers and groups developed for the first version of Cemat were also replaced and extended from update to update. While each new version contains the latest technological innovations, the organization and core functions of the modules have always remained the same.

These constant updates are Cemat's recipe for success, because they ensure that every new version of the process control system is backwards compatible with all previous releases. In the meantime, the Cemat library has become a standard, not only for cement plants, but also for mining operations and related industries. Today, all leading cement plants in Europe employ Cemat. And with more than 800 installations worldwide, it is the leading process control system for the cement, mining and related sectors. In short, it is an industry standard.

A trusted tool

No wonder, then, that for decades large companies have been using Cemat across their operations – one of which is HeidelbergCement. Markus Konecki, Engineering/Senior Project Manager at HeidelbergCement Germany: "We have been using Cemat for more than 30 years now. It's one of our standard process control systems because of its high market acceptance and Siemens' long experience in the industry. Moreover, Cemat offers customized configurations that keep things simple."

HeidelbergCement is currently investing more than €100 million in the modernization of its plant in Schelklingen, Germany. The site came into operation in the mid-1970s and currently provides kiln production

capacity of approximately 3,500 tons per year of clinker. The modernization, which is set to be completed this year, will transform the site into one of the most modern plants in Germany, if not in Europe, with an annual capacity of 1.5 million tons of clinker.

At the core of the project is the construction of a new line according to the latest standards – including a new heat exchanger furnace with a rotary kiln, clinker cooler and exhaust gas purification system. The new line will replace the two existing rotary kilns at the site. Keeping with tradition, Cemat will continue to play an essential role. "Since 1987 we have been using different Cemat versions in this cement plant location. Especially for our new kiln line, we will be using the latest state-of-the-art process control system Cemat Version 9.0," says Stephan Wehning, Plant Manager of the HeidelbergCement Schelklingen site.



About HeidelbergCement

HeidelbergCement is one of the world's largest integrated manufacturers of building materials with leading market positions in aggregates, cement and ready-mixed concrete. The company employs 60,000 people at more than 3,000 locations in around 60 countries.

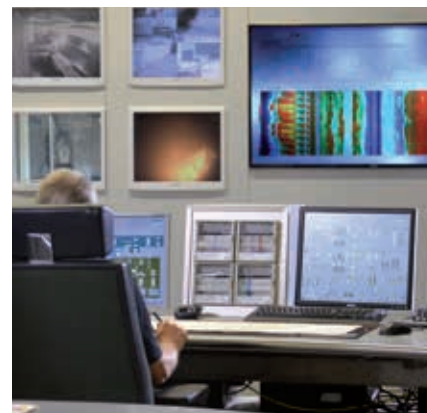

The focus of development work on Cemat Version 9.0 was to optimize the control system and integrate innovations that make work easier for operators.

New features in Cemat

Cemat Version 9.0 includes improvements to existing functions as well as a number of new functions. For example, the process control system covers the entire automation chain, from the extraction of raw materials to the packaging of the end products. With integrated operating and diagnostic functions, potential malfunctions can be detected more quickly and downtimes minimized. "Our development work for Version 9.0 focused on optimizing the control system. In addition to these improvements, there are a number of impressive innovations that make work easier for engineers and plant operators," says Johannes Vorsamer from the Cemat development team at Siemens.

Investment security is ensured by the fact that Version 9.0 is still backwards compatible with all previous releases up to version 1.8, which was introduced in 1987. This means that even older PLC programs can still be operated and integrated into the latest version of the process control system. In short, the decision for Cemat can be made with a clear conscience – which is proven by Heidelberg Cement's repeat trust in the Siemens process control system. ■

➤ www.siemens.com/cement

Author: Thomas Walther
thomas.walther@siemens.com



For higher availability and efficiency

“Digitalization is technology to collect, store, analyze and use data to the benefit of customers.”

Ömer Oydaşık, Head of Cement at Siemens

Digitalization is the buzzword in nearly every industry today – and cement is no exception. In the following interview, Ömer Oydaşık, Head of Cement at Siemens, talks about the different digital solutions Siemens has on offer for the cement industry, and what lies on the horizon.

What is Siemens' primary goal with digitalization for the cement industry?

Our mission is to help clients increase the availability and efficiency of their plants. That includes operating plants better, increasing volumes if need be and, of course, saving money. What's more, we offer solutions for the entire plant life cycle.

When you say life cycle, what do you have in mind here? Where do you begin with digitalization?

We start with general engineering, which has changed quite a bit over the last few years. Today, intelligent engineering tools that combine all different disciplines have become the norm. Mechanical, electrical and chemical engineering – to name just three – can work in a combined database or engineering platform. If a change is made in one area, it is automatically made in all the other disciplines too. Our customers report a significant increase in the efficiency of the engineering work.

The platform we offer here is Comos, which has been well accepted by engineering firms in the cement industry. The great point is that after engineering, modules in Comos provide the operator with the complete plant engineering data. It helps with planning, and if a revision is carried out, the data can be adjusted accordingly.

Let's move to day-to-day operations. This is where the process automation system Cemate enters the picture, right?

Yes, that's correct. Cemate is the first product we developed exclusively for the cement industry. Cemate turns 45 this year. Starting with initial installations in Germany, the process automation system soon captured the market, and today more than 30 percent of players in the cement industry are using Cemate. The solution is also widely available: providers include Siemens itself, Siemens' partner network and several EPCs.

For us, strong process automation like Cemate is the basis for digitalization in cement plants. Above and beyond that, we are entering other realms of digitalization for daily operations.

For example?

Like I said, the main priority is to help cement manufacturers to operate their plants better – to save money and increase productivity. To achieve the best outcome, we optimize different applications using Internet of Things (IoT) tools, for example MindSphere.

MindSphere is the cloud-based, open IoT operating system from Siemens for the Industrial IoT, or IIoT. Different apps can be created using MindSphere, such as for condition monitoring. Here sensors on motors, drives and gearboxes deliver data to the cloud. The data is then analyzed by algorithms, which in turn issue automatic warnings before a failure is likely. Apps like these go a long way to increasing plant efficiency.

Let's take this a step further. MindSphere can also obtain data from Cemate. And when you combine the two, customers benefit from more added value. For example, the data generated can also help us to make recommendations for changes during a planned shutdown.

With the cloud solutions you describe, data ultimately leaves the plant. What steps does Siemens take to ensure security?

You've touched on an important point, as security services are now more important with IIoT and data transfers. The data and communication structure in a plant needs to be made secure, which is why we go beyond standard firewalls consultancy services to help clients improve their plant's security from an IT point of view. Our scope covers general IT topics as well as industrial automation and process control systems.

A number of cement companies have several locations across the globe. What digitalization solutions support them, for example in comparing metrics from different locations?

The topic here is digital transparency, which is a key issue for a lot of our customers – and not just for companies with plants in different countries, but also for local players with several plants. The basic need is to understand what is going on in different plants and to maintain complete control from one

location. Therefore, we have created digital architecture to get the necessary data from automation systems, transfer data, performance figures, asset management, etc. With this enterprise data in hand, management obtains a clear picture of aspects from key data, for example energy consumption and production volumes, and thereby gains control of the complete value chain. In the mining sector, a customer in Brazil has adopted this architecture for its operations and estimates savings of more than €70 million by 2020.

How far along is the cement industry in this respect?

We have started several pilot projects with cement customers. However, the cement industry can also take examples from Siemens' successful references in the mining industry. In the end, digitalization is technology to collect, store, analyze and use data to the benefit of customers. But that can only be done together with customers. Our approach is to sit together with our customers, discuss their challenges, and offer tailored-made solutions based on digitalization that brings benefit to their operations.

What possibilities do you see for digitalization in the future?

The market is changing. In developed countries, overcapacity is a reality. Cement manufacturers in these parts of the world need to optimize their costs: digitalization gives them more transparency for more efficiency. When the time comes for modernization, automation simplifies the process and doesn't require huge engineering investments. In other parts of the world, greenfield plants are being built. In places like Africa, there is a need for technology because of the difficulties associated with finding skilled personnel to operate plants. There's even the possibility of central control rooms to monitor and operate different cement plants in different locations. Cemate is key in these efforts, because the basic topography enables the establishment of remote control. ■

➔ www.siemens.com/cement
omer.oydasik@siemens.com

Bigger and better

An extensive modernization project has allowed a cement company in Texas to increase production, energy efficiency and availability – and improve plant safety. A project highlight: the introduction of the biggest UL-certified induction motor ever to be produced in the United States.



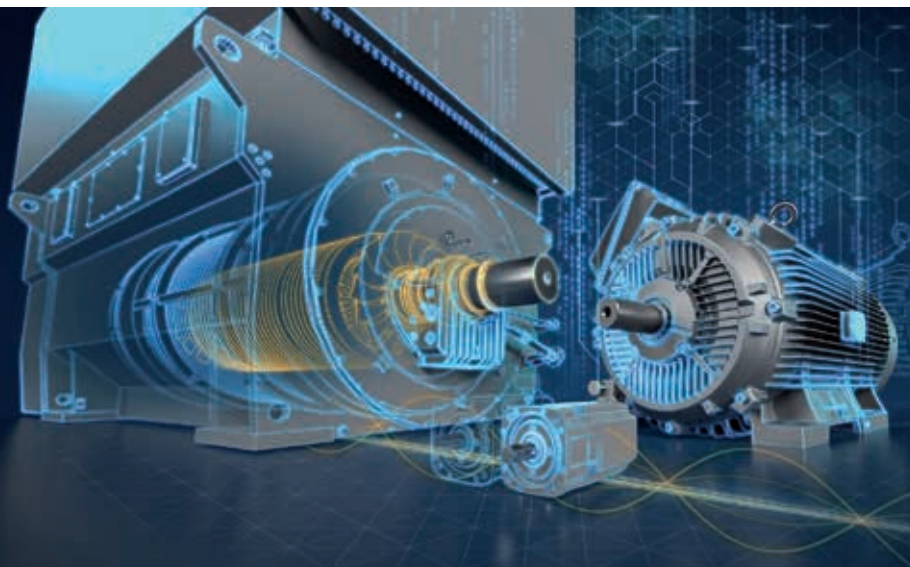

Above: Thanks to good planning and the right selection of equipment, the lead time of just 32 weeks for the modernization project was kept.

Left: Components from Siemens, including a new Simotics motor, help the customer produce cement more efficiently and achieve higher production rates. In addition, safety at the plant has been improved.

Operators of the cement production facility had clear goals for an extensive modernization project: they wanted to attain higher production rates, as well as increase availability and energy efficiency. And at the same time, the modernized plant would have to improve plant safety. Most of all, it was important that the complex project be in good hands. Thus Siemens and thyssenkrupp Industrial Solutions (TKIS) – two well-known companies in the field of industrial drive technology and power distribution – were chosen to carry out the modernization in 2017.

The Siemens equipment implemented in the project included a liquid immersed isolation transformer that uses biodegradable

FR3, an environmentally friendlier alternative to mineral oil; 24-pulse Sinamics GM150 frequency converters with CSA certification; an air-cooled IP55 totally enclosed air-to-air cooler (TEAAC); a variable-speed 2000 HP Simotics induction motor for the mill; and a power distribution center (PDC) that was tested prior to installation in order to reduce the time needed for commissioning.

Breaking a US record

The new Simotics motor, which replaced the previous synchronous model, is noteworthy for a number of reasons: For starters, it's the largest UL-certified induction motor ever produced in the United States. It goes without a DC (direct current) circuit in the motor, enables rapid diagnostics and troubleshooting, and offers capability for remote support. What's more, its variable speed control allows the plant operator to directly control the grinding process by adjusting the speed accordingly. Because the motor has fewer spare and wear parts than the previous drive, it requires exceptionally little maintenance. All of this together helps increase the plant's availability.

Thanks to good planning and the right selection of equipment, the lead

Cement for Texas and beyond

This cement customer's production plants stretch across the entire south and southeast of Texas. Presently the company manufactures and markets four different types of construction cement, three API Spec Oil Well cements (Class A, Class C and Class H), and masonry cements for sale to its Texas and out-of-state customers. The company's objective to be the highest-quality, low-cost producer of cement products in Texas is matched by its desire to maintain a safe working environment for its many employees and operate according to today's environmental requirements.

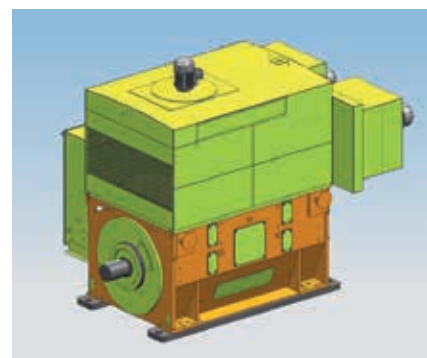

The customer is operating the largest UL-certified induction motor ever produced in the United States.

time of just 32 weeks for the modernization project was kept. And right in line with the customer's wishes, the plant has been operating more efficiently and safely, and with higher productivity and availability. ■

➤ www.siemens.com/cement

Author: Ömer Oydaşık
omer.oydasik@siemens.com

Published by:

Siemens AG
91052 Erlangen, Germany
siemens.com/mining
siemens.com/cement

Responsible for content:

Roland Ehrl
Thomas Walther

Concept, coordination: Daniela Michel-Fracci

Editorial committee:

Thomas Walther
Karen Chong

Concept, editing, design:

Agentur Feedback, Matthias Weiner, Munich, Germany
www.agentur-feedback.de

Editorial staff: Alexander Chavez

Art direction: Monika Gollasch

Photographs: Siemens AG

Print: PASSAVIA Druckservice, Passau, Germany

Circulation: 2,000

© 2019 by Siemens Aktiengesellschaft Munich and Berlin.

All rights reserved.

Article number: VRMI-M10032-00-7600

The following products are registered trademarks of Siemens AG:

Simatic PCS 7, Simatic S5, Simatic S7, Siemens Minerals Operation Management Solution, Siemens WinCC Open Architecture, SmartMining, Asset Health Analytics, Cemat, Cemat MinAS, SGT-A45, Digital Drive Train Services, Simotics, Comos

If there is no special mention of trademarks, trade names, technical solutions, or similar items, this does not mean that these items are not protected.

The information in this magazine contains only general descriptions and performance features which do not always apply in the described form in the actual application or which may be subject to change in the course of further development of the product. The specific performance features are only binding if they were agreed expressly in the contract.

