

Features and Ratings

- MODULE RATING: 800 AMPS, 240V AC MAX.,
- 1 PHASE
- 100,000 AIC RATING MAX, SEE DIAGRAM FOR DETAILS
- TYPE 3R OUTDOOR ENCLOSURE
- FOR OVERHEAD OR UNDERGROUND SERVICE
- MOUNTING RAILS AND ADJUSTABLE BRACKETS FOR SECURE MOUNTING



Lug Kits and Replacement Parts

Lugs for Phase and Neutral Connections (not supplied)					
Lug No. ①	MFG	Wire Range	Type	No. Wires per phase	Torque (lb.-in.)
LK12600N2	Siemens	#2-600 kcmil	Mechanical	2	500
LK12750N2	Siemens	300-750 kcmil	Mechanical	2	500
LK13500N2	Siemens	1/0-500 kcmil	Mechanical	3	500 ②
2ACL-500	ILSCO	500 kcmil	Compression	3	NA ③
2ACL-600	ILSCO	600 kcmil	Compression	2	NA ③
2ACL-750	ILSCO	750 kcmil	Compression	2	NA ③

- ① Order one mechanical lug kit for mains and neutral. Contact lug manufacturer for compression lug quantities supplied for each kit.
 ② Kit contains more than one lug type.
 ③ See lug manufacturer's instruction sheet supplied with the connector for tool, die, and number of crimps.

Schematic

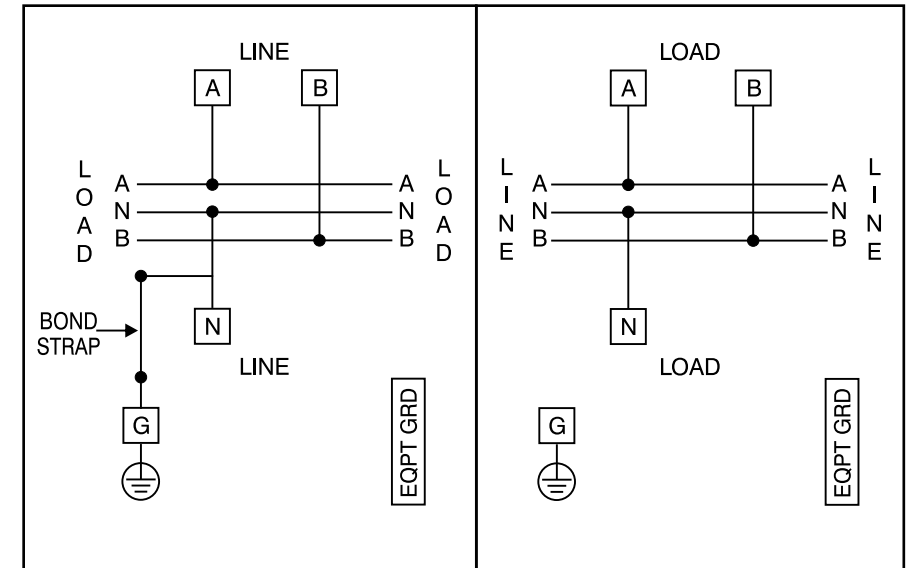

Terminals A, B, and N:
See Lug Chart for applicable lug kits, wire size and torque information.

Ground Terminal G: Wire size #4-300 kcmil.
Torque terminal to 250 lb.-in.

VIEW SHOWN WITHOUT COVER

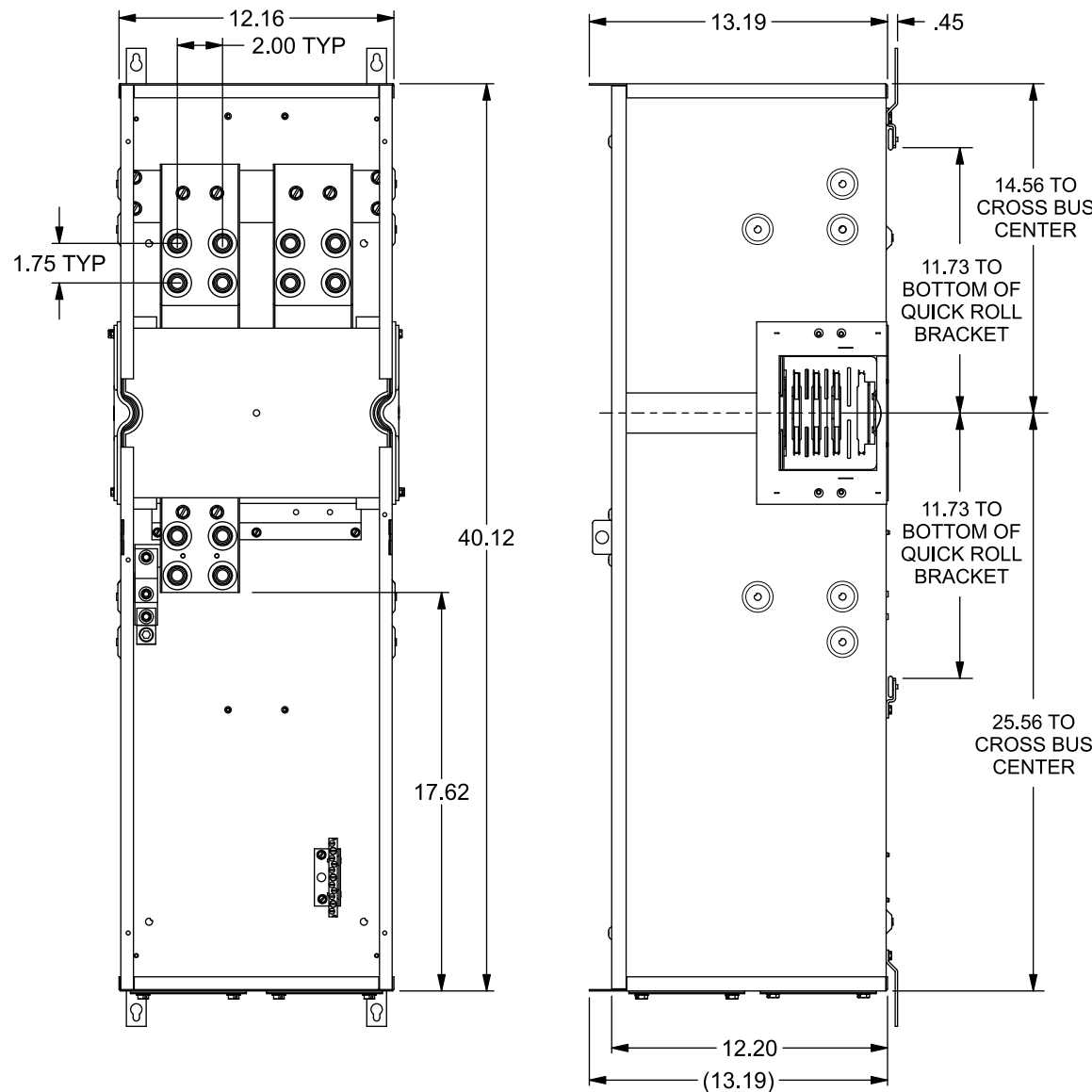

END PLATE INSTALLED (BOTH SIDES)

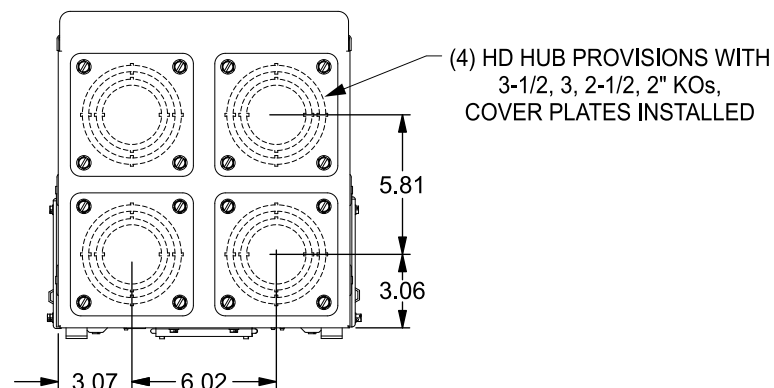

Additional Modules

IMPORTANT - for use with:

Module Description	Siemens Series#
Main Breakers	WB(M), WEB(M), WXB, BFT
Switches	WMP, WS, WES, WXS
Tap/Terminal Boxes	WTB, WET, WT_PU, WTBN, WBT
Pull Boxes	WMMB
Meter Module	(W)MM, (W)MT, (W)ML, (W)MK, (W)MLZ(F), (W)MN
Meter Combinations	WC, WCL, WCT,
Extension Box	WSP, WSPD
Bussed Elbow	BE, WELB

Connect Modules Using: Cat. No. Torque
 Quick Connect QC1 400-440 lb-in (35-36 ft.-lb.)

Accessories

Siemens Accessories	Catalog Number
HD Hub Cover Plate	EC56933S
Type HD Hub 2"	EC56854
Type HD Hub 2-1/2"	EC56855
Type HD Hub 3"	EC56856
Type HD Hub 3-1/2"	EC56857
Type HD Hub 4"	EC56858

© 2018 Copyright Siemens Industry, Inc.

SIEMENS
Siemens Industry, Inc.

PowerMod™ Tap Boxes

Description: **800A, 1 Phase, OH/UG Tap Box w/Hub Provisions**

KAM 1/31/18 DO NOT SCALE DRAWING Dwg No: **WTB1800CU**

Catalog No. WTB1800CU