

SIEMENS	INSTALLATION AND OPERATION MANUAL FOR REDU	Doc No:	IOM-005
		Rev No:	1
		Category:	Production
		Created By:	XY Teng
DISTRIBUTION CONTROL: RESTRICTED			

INSTALLATION AND OPERATION MANUAL FOR REDU

1. SCOPE

This document applies to all Retrievable Electrical Distribution Unit (REDU) of the welded fabrication type.

2. PURPOSE

This document is an overview of the protection, storage, shipment, unpacking, deployment, and maintenance instructions for the Retrievable Electrical Distribution Unit (REDU).

Siemens Connectors and Measurements recommend the termination of all electrical equipment only be undertaken by suitably trained and qualified personnel.

SIEMENS	INSTALLATION AND OPERATION MANUAL FOR REDU	Doc No:	IOM-005
		Rev No:	1
		Category:	Production
		Created By:	XY Teng
DISTRIBUTION CONTROL: RESTRICTED			

3. TABLE OF CONTENTS

1	SCOPE	2
2	PURPOSE	2
3	TABLE OF CONTENTS	3
4	HEALTH AND SAFETY	4
5	DIGITRON ELECTRICAL AND MECHANICAL SPECIFICATION ON THE REDU	6
6	PROTECTION, HANDLING AND SHIPMENT	7
7	UNPACKING	7
8	STORAGE	8
9	DEPLOYMENT AND MAINTENANCE	10
10	BASE PLATE INSTALLATION	11
11	MATE/DEMATE OF REDU BOX TO BASE PLATE	12

SIEMENS	INSTALLATION AND OPERATION MANUAL FOR REDU	Doc No:	IOM-005
		Rev No:	1
		Category:	Production
		Created By:	XY Teng
DISTRIBUTION CONTROL: RESTRICTED			

4. HEALTH AND SAFETY INSTRUCTIONS

- Siemens controls the hazards within our standard processes by documented Risk Assessments. Special and One-Off process hazards must be identified and controlled by a “Tool Box Risk Assessment Card” (TRAC). In either case work must not commence until the identified control measures and systems of working have been implemented and the process considered being as safe as is reasonably practicable.
- The control of chemicals and substances is critically important for the protection of staff. All chemicals and substances entering the factory must be COSHH (Control of Substances Hazardous to Health) risk assessed and the identified control measures to protect against exposure have been implemented.
- Manual Handling, Lifting and Carrying are known to be the largest contributors to occupational ill-health. Ensure that mechanical handling aids are used whenever possible to avoid manual handling. As the weight of the Termination Unit will be in excess of 20kg in weight, then task safe manual handling/lifting guidelines must be followed, e.g. adopt correct postures, consider team lifting, employ safe lifting technique, etc.
- When using the soldering iron and sharp tools, use appropriate protective gloves
- Only competent persons are permitted to perform tasks without supervision, if in doubt ask.
- Good Housekeeping avoids Slips Trips and Falls, keep your area clean and tidy.
- It is the operator’s responsibility to comply with current Company & UK health and safety legislation.
- In the event that assembly and pressure testing is to be carried out at the customers or a third parties premises a written undertaking shall be obtained from the customer or third party that health and safety requirements shall be met. The testing of this connector involves activities that are potentially hazardous, for example high voltage and high-pressure testing. Each potentially hazardous activity must be preceded by a documented risk assessment to ensure that dangerous conditions are eliminated and that the risks are controlled. The test technician must not start work until the risk assessment has been documented and the safe practices discussed.
- All tests shall be carried out within a test cell, or specifically designed test area, which shall be clearly identified. Controlled access to such areas shall be enforced.
- Caution shall be exercised during assembly and testing to ensure that fittings and hydraulic/pneumatic equipment are properly installed.
- Under no circumstances shall pressurized connections be adjusted. Pressure must always be vented prior to such action.
- When performing pressure testing above the boiling point of the test medium. Ensure that a TOOL BOX Risk Assessment is conducted to ensure there is no possibility of personnel receiving injuries from high pressure steam or other vapours.
- All high pressure/temperature gas, hydraulic or hydrostatic test shall be subject to a risk assessment and all instructions and procedures which results are to be strictly adhered to.
- All high voltage testing shall be performed by trained personnel using equipment that has been checked for safety within the last 12 months from the date of use. The operator

SIEMENS	INSTALLATION AND OPERATION MANUAL FOR REDU	Doc No:	IOM-005
		Rev No:	1
		Category:	Production
		Created By:	XY Teng
DISTRIBUTION CONTROL: RESTRICTED			

shall be protected from electrocution by earth-screened enclosures that contain the H.V. hazard. These enclosures shall be fitted with interlocks to isolate the power before entry.

- After every H.V. test, an earth stick shall be used to verify that the conductors are discharged.
- For tests involving D.C. sufficient time must be allowed for the circuit to discharge before touching the conductors. The discharge period shall be at least equal to the period of charging.
- It is the responsibility of the lead engineer to review the specification of the available pressure vessels here at SIEMENS (Pressure Vessel Index). To determine their suitability for the test in question, during the qualification procedure. However, this does not remove the need for a "Tool Box Risk Assessment" on any testing involving pressure vessels or otherwise.
- Before using a knife to prepare cables, refer to Risk Assessment 030 (Q-Pulse ASSEMBLY-030)

5. DIGITRON ELECTRICAL AND MECHANICAL SPECIFICATION ON THE REDU

- Maximum working voltage: 1000V rms phase to earth
2000V rms phase to phase
- Working pressure: 400 bar
(13,120 ft / 4,000 meters water depth)
- Working temperature range: -5 to +60°C
- Storage temperature range: -40 to +70°C
- Onshore testing temperature range: -20 to +50°C
- REDU max weight in air (11 way): 91kg
- Base Plate max weight in air: 36kg

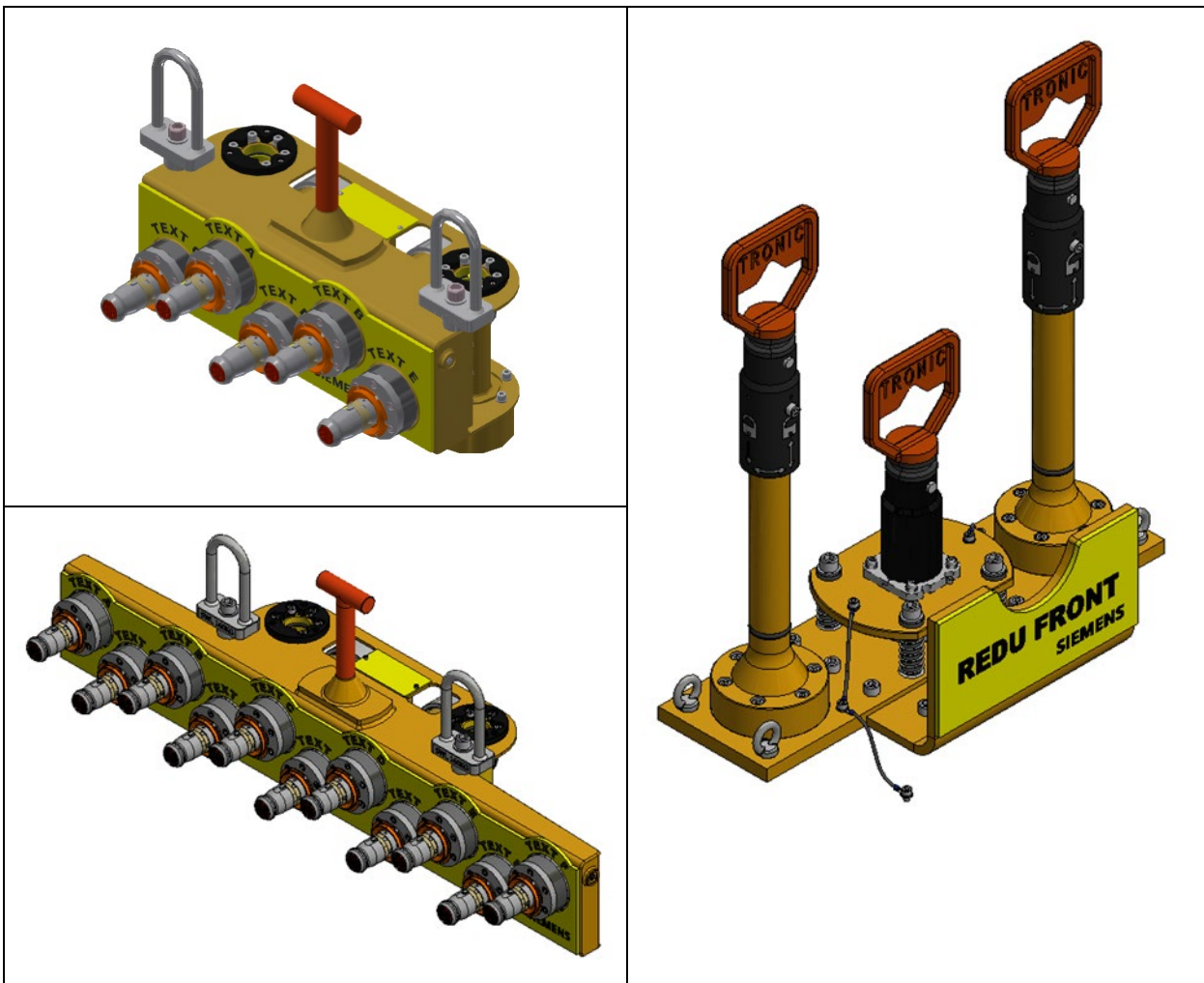

Fig.1 REDU BOX ASSEMBLY & BASE PLATE ASSEMBLY

SIEMENS	INSTALLATION AND OPERATION MANUAL FOR REDU	Doc No:	IOM-005
		Rev No:	1
		Category:	Production
		Created By:	XY Teng

6. PROTECTION, HANDLING AND SHIPMENT

- 6.1 Never attempt to lift the assembly or any part of it manually. Always use a crane or other suitably rated lifting device.
- 6.2 The REDU box is equipped with two ROV compliant lifting eyes (OPTIONAL CUSTOMER TO CLARIFY). These two lifting eyes are to be used to secure buoyancy aids when deployed; they may also be used for handling of the REDU box prior to deployment. Ensure the lifting eyes have been assembled and fixed in the correct orientation as shown on the relevant assembly drawing.
- 6.3 The 'T' bar handle should not be used as a sole lifting point until the assembly is Subsea and should only be used to lift the REDU Box from the base plate.
- 6.4 The REDU box and base plate are NOT to be lifted as a single assembly. Utilize the two lifting bolts on the REDU box and the 4 lifting eyes on the Base assembly during any handling manoeuvre.
- 6.5 The REDU is manufactured primarily from 316L stainless steel (UNS S31603), and as such is designed to withstand harsh environments. However, if not adequately protected, the connector inserts and exposed parts are susceptible to mechanical damage. Dust caps are fitted to all Siemens connectors before transport, but protective caps will be fitted if specified by the customer.
- 6.6 Care should be taken to avoid surface damage to Box Body and connectors during transit.
- 6.7 The REDU is designed to withstand vibration that occurs during transportation.

7. UNPACKING

- 7.1 Remove from packing box, taking care to inspect for any surface damage or items that may have become separated from the product.
- 7.2 For parts supplied individually and wrapped in materials, do not use a knife to cut the wrapping material, as this may cause damage to any elastomeric parts or painting of the product.
- 7.3 Protection caps should not to be removed until the REDU is ready for installation.

8. STORAGE

8.1 Short Term Product Storage:

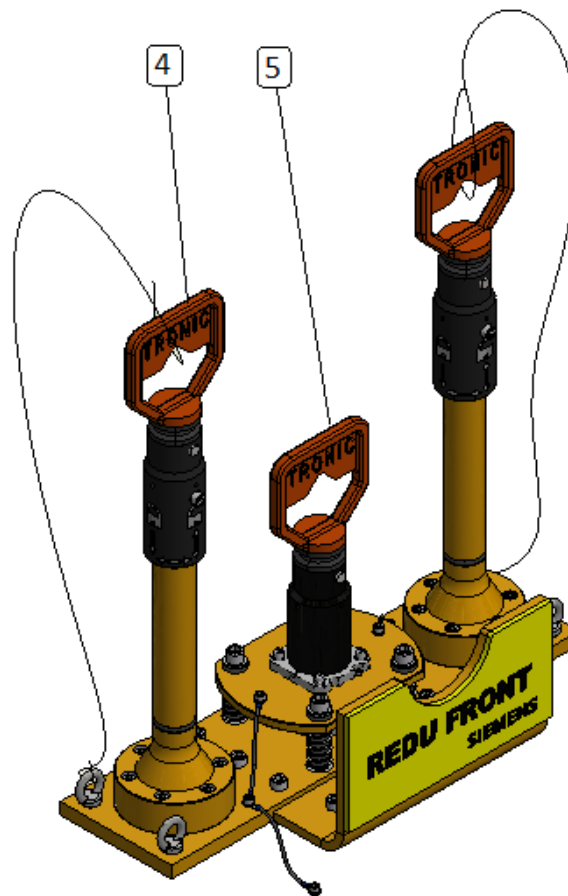
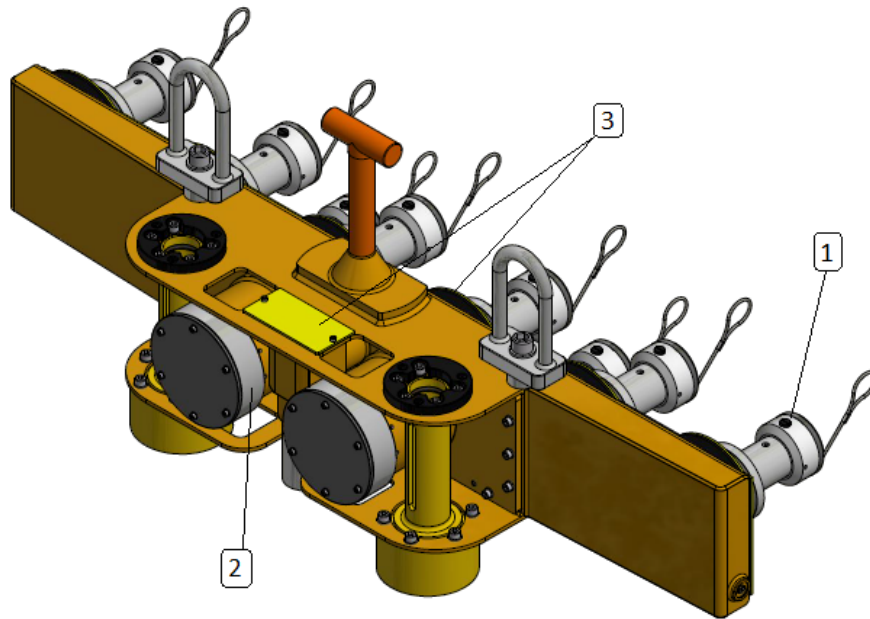

Fig.2 SHORT TERM PROTECTION

SIEMENS	INSTALLATION AND OPERATION MANUAL FOR REDU	Doc No:	IOM-005
		Rev No:	1
		Category:	Production
		Created By:	XY Teng

8.1.1 Connectors (1) and Compensators (2)

Prior to installation the connectors and compensators are sensitive to environments where grit and dirt are present. To prevent ingress of the above, they should be stored in a clean dry area and the connectors to be protected by dust caps or protection caps. Dust caps or protection caps to be only removed prior to deployment.

8.1.2 Aquasign® Labels (3)

The fluorescent pigments used in the Aquasign® labels are susceptible to fading when exposed to direct sunlight. It is therefore essential that the protective covers supplied with the labels are only removed prior to deployment.

8.1.3 Stab Plate Connector (Dummy Connector) on Base (if applicable)

Dust Cap or Protection Cap (5) for the Stab Plate Connector (Dummy Connector) on the Base to be removed prior to deployment only.

If the Base is to be deployed for a long period of time without REDU box, then the Protection Cap (5) must be deployed with the Base, but to be removed as late as possible prior to the Box being installed onto the Base.

8.2 Long Term Product Storage:

- 8.2.1 The product must be stored in a clean dry area and should be kept in the packing box. Suitable protection caps must be fitted, the storage temperature should be between -40°C and 70°C. Humidity of the store room should be maintained below 75%. Very moist or very dry conditions should be avoided. The Plug connectors and Aquasign® labels should be protected from strong sunlight and strong artificial light with a high ultra violet content.
- 8.2.2 The connectors should not be allowed to come into contact with solvents, oil, greases or any other semi-solid materials.
- 8.2.3 Please note: maximum storage temperature considers solar gain. Skin temperature must not exceed 70°C. Suitable protection must be used to ensure maximum storage temperature is not exceeded.

SIEMENS	INSTALLATION AND OPERATION MANUAL FOR REDU	Doc No:	IOM-005
		Rev No:	1
		Category:	Production
		Created By:	XY Teng

9. DEPLOYMENT AND MAINTENANCE

- 9.1 The following section details deployment and maintenance instructions for the REDU **Connectors information ref. to individual document IOM-003 (DigiTRON SCM Connectors Installation, Operations and Maintenance Manual)**
- 9.2 The REDU utilizes the DigiTRON range of connectors which have been developed for long term reliable signal and low power control system applications associated with offshore installations. The underwater mate-able capacity of these connectors is achieved using pressure compensated electrical inserts.
- 9.3 Connectors must not be energized Sub-sea unless coupled with a mating connector or fitted with a Dummy Plug or Receptacle. This is to prevent electrolytic damage to the contacts when exposed to sea water.
- 9.4 Connectors are usually supplied with protective caps. The protective caps must be removed prior to mating the connectors.
- 9.5 Prior to deployment, remove the protective cover from the Aquasign® Labels.
- 9.6 If the connectors are to be left unmated, in seawater, for any length of time dummy connectors must be used to protect the pin contacts in the receptacle connectors. Over exposure will increase the risk of corrosion damage or marine growth on the contact surfaces of the receptacle contact pins. This could lead to damage to the seals and insulation within the socket contacts. Plug connectors do not require full dummy connectors for protection. Siemens C&M advise the fitting of acetal caps to protect plugs against marine growth. It is good practice to always fit the protective cap when a connector is unmated topside prior to deployment to provide mechanical protection.
- NOTE: 28 DAYS IS THE MAXIMUM CUMMULATIVE ALLOWABLE EXPOSURE OF UNPROTECTED CONTACT PINS TO SEAWATER OVER THE LIFE OF THE CONNECTOR. THIS ONLY APPLIES WITH POWER OFF.**
- 9.7 The appropriate test connector must always be used to make electrical contact during testing. UNDER NO CIRCUMSTANCES should a foreign object (such as a screwdriver, test probe, or crocodile clip) be used as a test connection as this could damage the seals and insulation. Such actions will invalidate the warranty of the connector.
- 9.8 Guide pins must never be removed from test connectors as this can lead to damage and will invalidate the connector warranty.

NOTE: NO PART OF THE CONNECTORS SHOULD BE DISMANTLED PRIOR TO OR DURING DEPLOYMENT, APART FROM THE REMOVAL OF PROTECTIVE CAPS, SINCE THERE ARE NO USER SERVICEABLE PARTS INSIDE.

SIEMENS	INSTALLATION AND OPERATION MANUAL FOR REDU	Doc No:	IOM-005
		Rev No:	1
		Category:	Production
		Created By:	XY Teng

10. BASE PLATE INSTALLATION

- 10.1 The standard base plate is supplied with 6-off M10 x 40mm socket head cap screws, torque to 35Nm and apply a spot of Loctite 243 to the threads during installation (other fixing options are available upon request).
- 10.2 Mount the base plate in a horizontal position, ensure that the floating spring mounted stab plate connector hose assembly (or dummy connector) is not constrained in its movements and that the connector it is aligned at 90 degrees to the base plate. It is integral to the design that the connector must be allowed to float so that misalignment tolerances can be accommodated.
- 10.3 The base plate assembly has been manufactured from UNS S31603 and must be connected to the host structures CP (Cathodic Protection) system at all times using the leads provided.
- 10.4 The Aquasign® Labels utilized on this product are antifouling, providing exceptional long-lasting resistance to all forms of marine growth.
- 10.5 The Locking Caps (item 4 in Fig.2) are supplied together with the Base.

To avoid losing the Locking Caps, Siemens advise that the customer ties the Locking Handles onto the Base Plate Lifting Eyes allowing enough wire length (ref. to Fig.2) to enable locking / unlocking and removal.

If the Base is to be deployed without the REDU Box the Locking Caps should be fitted to the Base during deployment but **MUST** be removed prior to the REDU Box being installed onto the Base.

11. MATE/DEMATE OF REDU BOX TO BASE PLATE

To complete a safe and successful mate/de-mate of the REDU Box to / from the Base Plate, the assembly must be horizontal to the vertical lift (optionally with the use of buoyancy aids). The maximum angular displacement must not be more than the maximum misalignment values shown in the following table:

The values stated relate to the offset between the primary location pin and the stated misalignment type.

Misalignment Type	Values
Horizontal	5° above the horizontal plane
End View	+/- 5° from the vertical plane
Plan View	+/- 3° from the center line of the primary guide post
Cone to Pin Concentric	Within a 35mm radius of the centre of the primary guide post

- 11.1 Make sure that the Protection Cap (if applicable) for the stat plate connector on the base plate being removed prior to mating. Ensure the Protection Cap is retrieved.
- 11.2 Prior to mating the REDU box, make certain that the stab plate connector located in the base plate is at 90 degrees to the base plate.
- 11.3 Make sure that Locking Caps are removed from the Posts prior to mating (if fitted on the posts earlier). And make sure that the REDU Box is locked correctly with Locking Caps after being mated onto the Base Plate (see Fig.3).

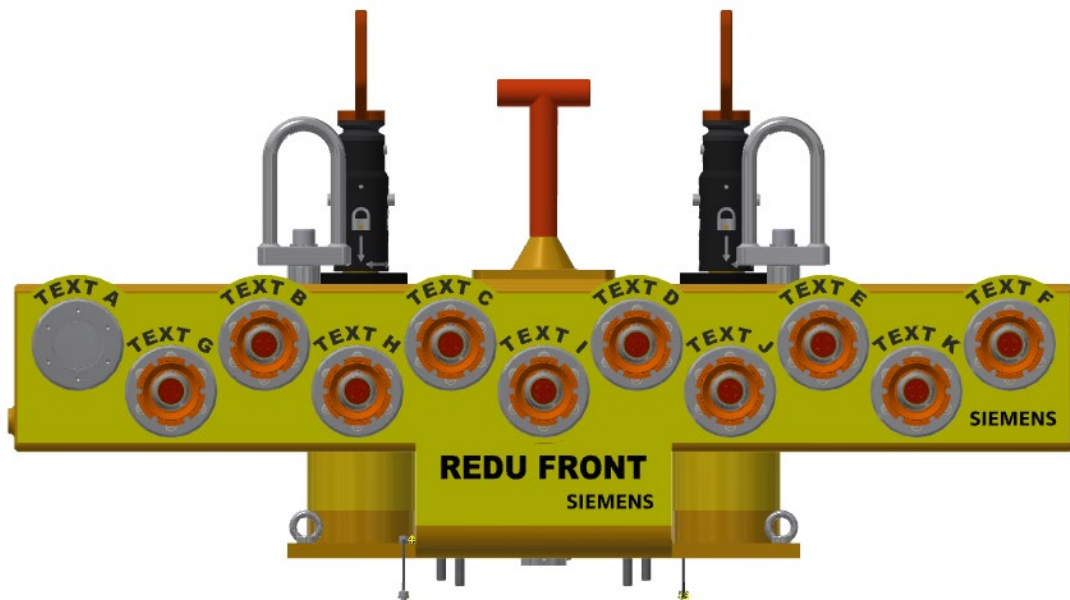

Fig.3 REDU BOX LOCKED ON THE BASE

- 11.4 To locate / land on both guide posts, the REDU box must be no more than +5 degrees above the horizontal plane and +/- 5 degrees from the vertical plane and within +/- 3 degrees between the center-lines of the guide posts (see Fig4 to Fig6).

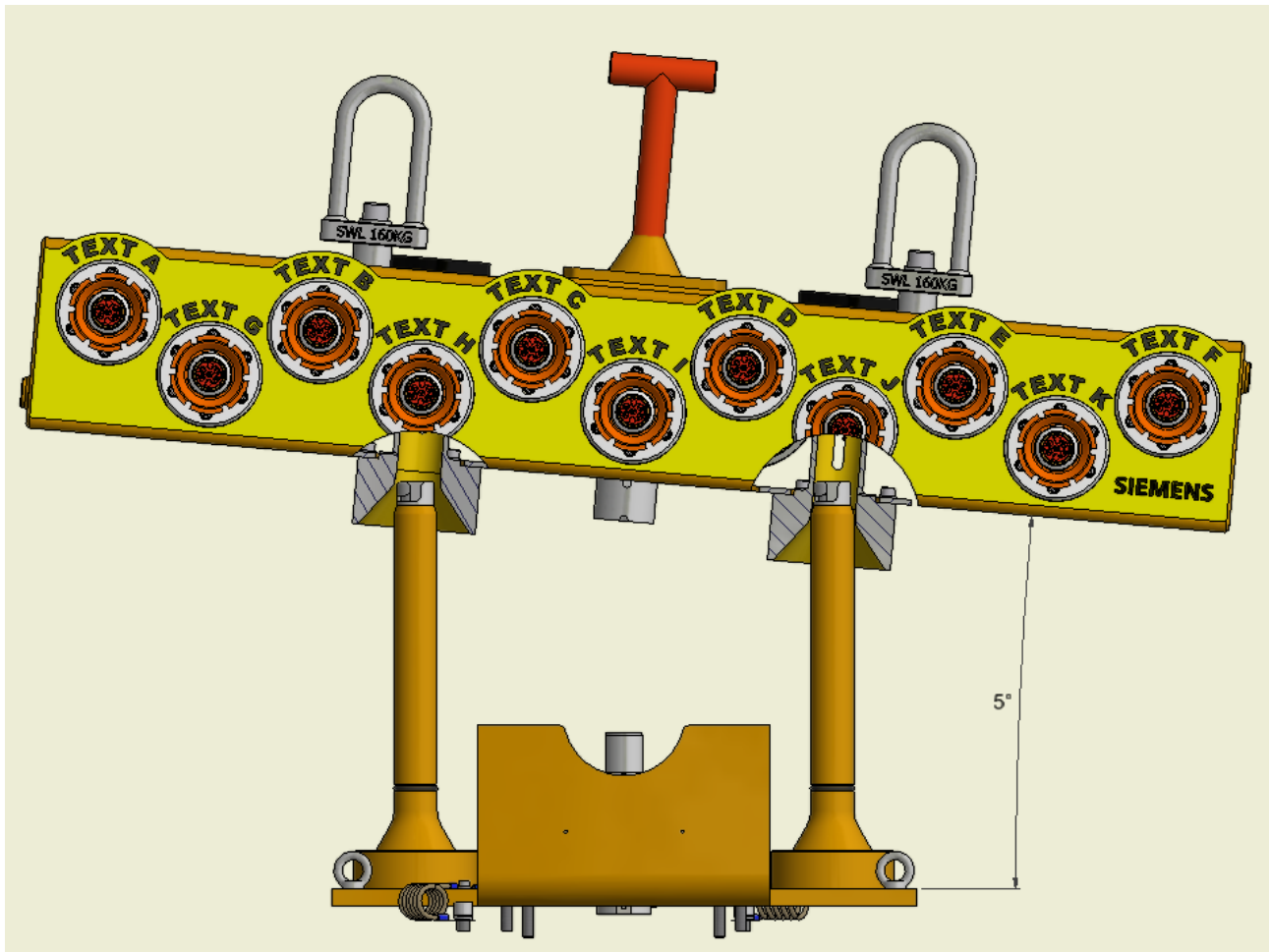

Fig.4 Misalignment 5° above the horizontal plane (Partial section showing engagement)

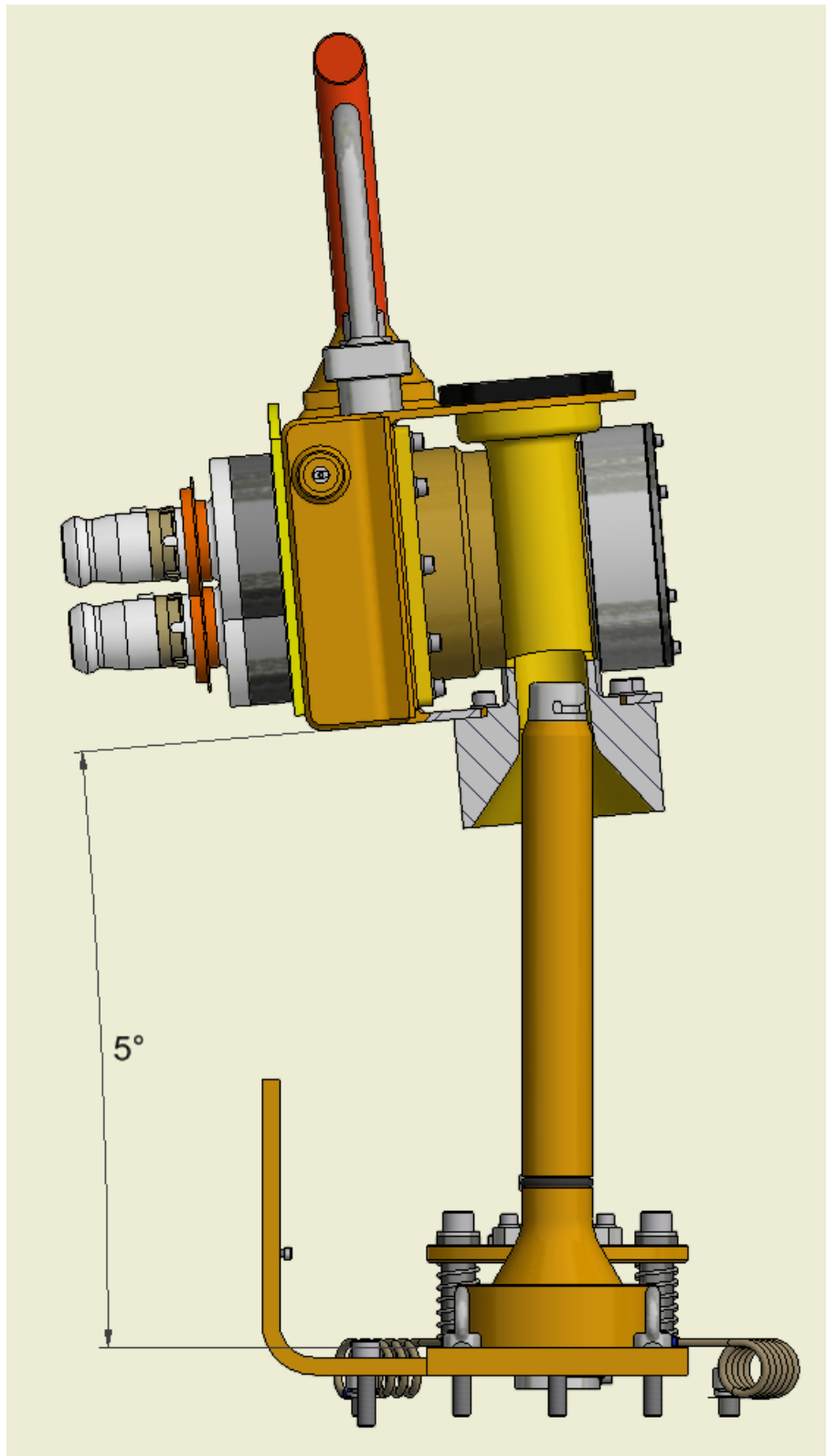

Fig.5 Misalignment 5° from the vertical plane (Partial section showing engagement)

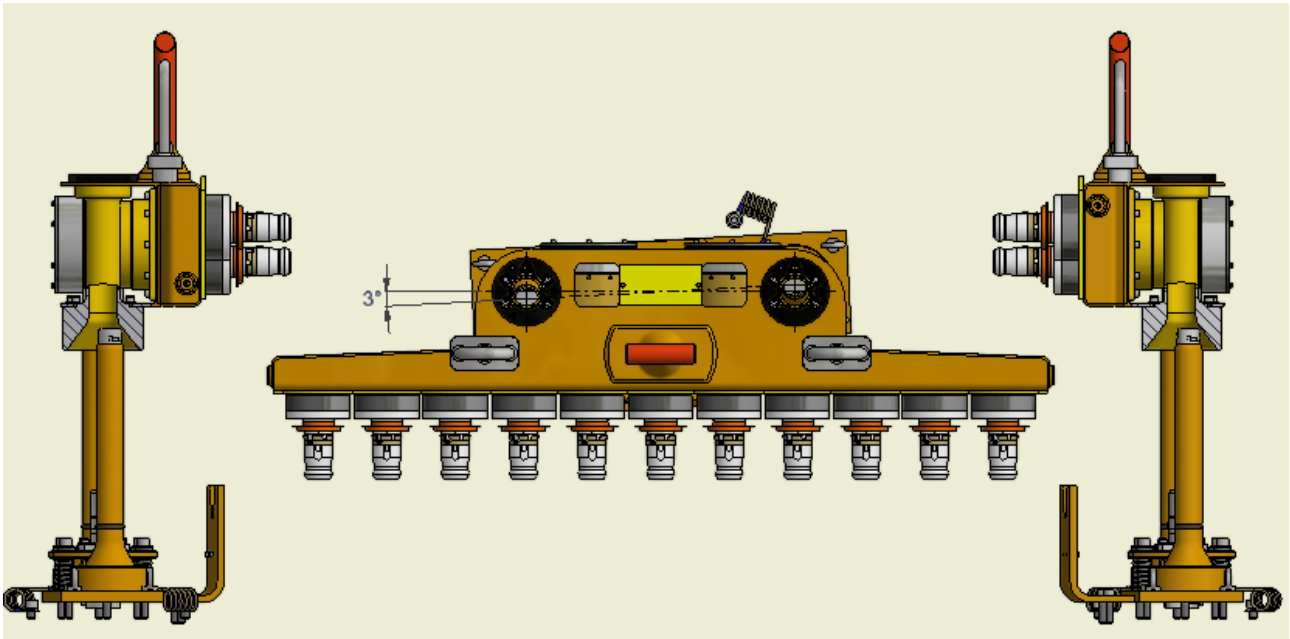

Fig.6 Misalignment 3° between centerlines of both posts

11.5 Maximum cone to pin misalignment: Figure 7 shows that location cone has a maximum allowable radial misalignment of 35mm around the vertical axis of the Guide Posts.

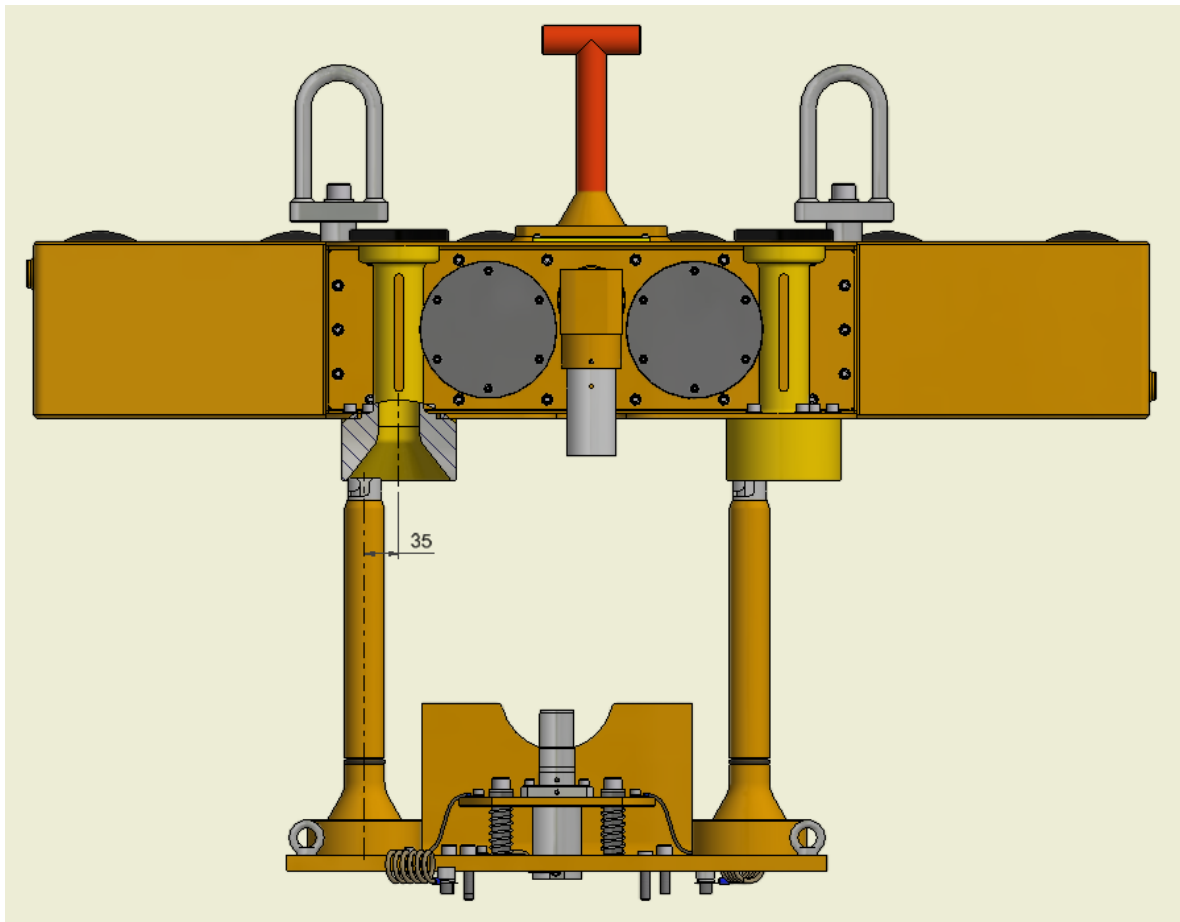

Fig.7 Allowable cone to Guide Posts concentric misalignment