

Circuit
Breaker
Lighting
Panel
Type P1

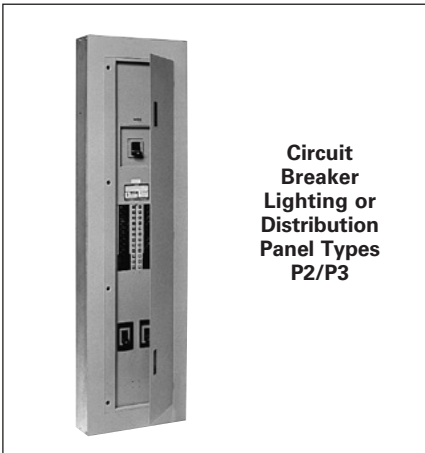

Circuit
Breaker
Lighting or
Distribution
Panel Types
P2/P3

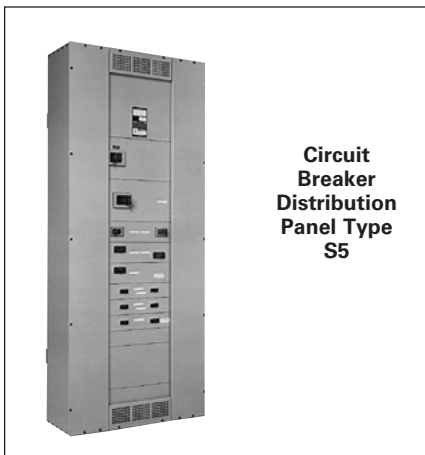

Circuit
Breaker
Distribution
Panel Type
S5

Contents

Features, Reference Guide & General Specifications	10-2 – 10-5
Factory Assembled Panelboard Coding System	10-6
Distributor Stock - Type P1 RTAP General info & Kits	10-7 – 10-14
Legacy Panelboard Replacement, Modification, and Additions	10-15
15A-125A Branch Breakers for Panelboards	10-16 – 10-19
Type P1	10-20 – 10-29
Specifications	10-20
Main Breaker, Main Lug, and Branch Breaker Config. Info	10-21 – 10-24
Modifications and Additions	10-25 – 10-26
Enclosure Dimensions - Type 1, 3R and 3R/12	10-27
General P1-P2-P3 Enclosure Information	10-28 – 10-29
Type P2	10-30 – 10-44
Specifications	10-30
Distributor Stock/Unassembled - Type P2 Main Lug Only	10-31 – 10-32
Main Breaker, Main Lug, and Branch Breaker Config. Info	10-33 – 10-37
Modifications and Additions	10-38 – 10-39
SEM3 Embedded Micro Metering Module	10-40 – 10-41
Enclosure Modifications, Kits, and Accessories	10-42 – 10-43
Enclosure Dimensions	10-44
Type P3	10-45 – 10-53
Specifications	10-45
Enclosure Selection/ Dimensions	10-46
Alternate Main, Branch, and Subfeed Breakers	10-47 – 10-48
Modifications and Additions	10-49 – 10-51
Kits and Accessories	10-52
Enclosure Dimensions	10-53
P1-P2-P2, S5, & F2 Distribution Circuit Breaker Connector Kits	10-54
Miscellaneous Accessories - Spare Part Kits	10-55 – 10-56
B74FLR Enclosures & Related Bottom Covers	10-57 – 10-59
Lighting panel ground bus information: P1, P2, P3	10-60
Type S5	10-61 – 10-65
Specifications	10-61
Main Lug and Main Breaker Selection	10-62
Branch Breakers	10-63
Modifications and Additions	10-64
Modifications, Additions, Replacements for Circuit Breakers	10-65
Type F2	10-66 – 10-71
Specifications and Fuse Types	10-66 – 10-67
Modifications and Additions	10-68
Modifications, Additions, Replacements for Fusible Switches	10-69
SEM3 Embedded Micro Metering Module	10-70
Panel Skirt/System Types, AC & DC Voltages	10-71
Type HCP Switchboard Units	10-72 – 10-73
Selection and accessories	10-72
Dimensions	10-73
Type C1/C2	10-74 – 10-81
Specifications	10-74
Main, Branch and Subfeed Breakers	10-75
Circuit Breaker / Column Type, Modifications and Additions	10-76
Conduit Enclosing Shield (Panel Skirts)	10-77
Enclosure/System Types, AC & DC Voltages	10-78
Dimensions and Panelboard Configurations	10-79 – 10-80
Fuse Curves	10-81

Panelboards

Introduction

General

This generation of panelboards from Siemens offers the high level of engineering and innovation you've come to expect from the leader in power distribution technology. The "P Series" line of panelboards offers a stepped approach to power distribution.

Additional strength has been added to an already rugged and durable panelboard family. Engineered specifically to provide maximum flexibility, the new designs simplify wiring and reduce material requirements making them easier to install and less costly than competitive products. At the heart of the product line is the extensive research and technology found among Siemens circuit protection devices – both fusible switches and molded case circuit breakers.

The line is anchored by the innovative P1. Featuring the industry's most flexible designs, the P1 virtually eliminates common errors, such as feed direction, and main lug versus main breaker. Increasing distribution is simplified by the ability to add feed-thru lugs. The Revised P1 design introduced in June 2015 has added extended circuits up to 66 and has available smaller enclosures with no subfeed option for added flexibility.

Subsequent steps in the P series offer increased capacity and more design options:

- The highly flexible P2 panel provides options to fit the most demanding specifications.
- Sized more like a lighting panel, the P3 panel packs the power of a distribution panel in a space-saving, highly flexible design.

- The powerful S5 and F2 are distribution power panels that allow circuit breakers as branch and main devices.

Siemens also offers a number of specialty panels, like column panels, SEM3 (Embedded Micro Metering Module™) and others. Don't see a panel to meet your requirements? Ask your Siemens representative about our custom capabilities.

Features Overview

P Series lighting panel features include Fas-Latch trim, which is popular among installers; the jacking screw system, that permits adjustments even after wiring has been installed; our exclusive split neutral, and more. Many panelboards have the capability of mixing and matching breakers of different sizes and ratings – or changing from main lug to main breaker, or adding subfeed breakers without changing the box size. Other models accept a wide range of fuse types, including Siemens exclusive Vacu-Break® technology.

Key Panelboard Features

	P1	P2	P3	S5	F2
Power Panelboard Applications	—	•	•	•	•
Convertible From Top Feed To Bottom Feed Or Vice Versa	•	—	—	—	—
Change From Main Lug To Main Breaker Or Add Subfeed Without Changing Enclosure Size ^②	•	—	—	—	—
Space-Saving, Horizontally Mounted Main Breaker	Up To 250 Amps	Up To 250 Amps	—	•	•
Short-Circuit Rating Label Giving Performance Level	•	•	•	•	•
Standard Aluminum Ground Assembly	•	•	•	•	•
Blank End-Walls Standard ^①	•	•	•	•	•
Bolted Current-Carrying Parts	•	•	•	•	•
Split Neutral	•	—	•	•	•
Connection Accessible From Front	•	•	•	•	•
Screw-Type Mechanical Lugs	•	•	•	•	•
Time-Reducing Wing Nuts To Secure Interior Without Tools	•	•	•	•	•
Main and Branch Devices Connected With Case-Hardened Hardware	•	•	•	•	•
Flush Lock, Concealed Door Hinges/Trim Screws	•	•	•	—	—
Symmetrical Interior Mounting Studs To Eliminate Upside-Down Mounting of Box	•	•	•	•	•
Interior Height Adjustment For Flush Applications	•	•	•	—	—
Standard Depth	5.75"	5.75"	7.75"	12.75"	12.75"
Accepts A Wide Range Of Fuse Types	—	—	—	—	•
Accepts Vacu-Break Fusible Switch	—	—	—	—	•
Accepts A Wide Range Of Circuit Breakers	•	•	•	•	•
Optional Compression Lugs	•	•	•	•	•

• Standard

① Knockouts are available for P1 & P2 (5.75" deep x 20" wide enclosures), and P3 (7.75" deep x 24" wide enclosures).

② For Revised P1, only when Subfeed Space is selected, Interior Part Number ends with "T". When "N" is at end there is no Subfeed Space available

Panelboards

General Specifications

General

Service Entrance Equipment

When a panelboard is used as service entrance equipment, it must be located near the point of entrance for conductors supplying the building. Panelboards must be identified as "Service Entrance" at the time of placing the order. This way they will be supplied with the appropriate CSA certification and labelling. Panels must include a connector for bonding and grounding neutral conductor. Please consult CSA, CEC and local inspection authorities for specification and installation guidelines.

Integrated Equipment Short Circuit Rating

The term "Integrated Equipment Short Circuit Rating" refers to the application of series connected circuit breakers in a combination that allows some breakers to have lower individual interrupting ratings than the available fault current. This is permitted as long as the series combination has been tested and certified by CSA. "Series Rated" must be identified at the time of placing the order.

Standards

CSA: C22.2 No.29. Certified under files # 93833
UL: 67 and 50. Listed by Underwriter's Laboratories, Inc., under "Panelboards" File #E2269 and #E4016.
NEMA: PB1.1

Wire Connectors[Ⓢ]

Standard wire connectors in Siemens panels are suitable for copper or aluminum cables rated 60/75 °C. Copper main lugs are a price-added option for most panel types and some Circuit Breakers (check with Siemens sales for availability). It should be noted that most copper lugs will only accept copper cables. Some applications, 100% rated framed devices in particular, require that the cable and connectors be rated 90 °C but are sized to the 75 °C tables.

Standard ground connectors are also suitable for copper or aluminum wire. Ground connector assemblies (EGK, IGK) have (6) 1/0 max. and (15) #6 max. connections. The 1/0 holes are capable of connecting up (3) #10 max. wires. Copper ground assemblies (ECGK, ICGK) are rated for copper wire only and have the same wiring capacity as the Al/Cu connectors.

Standard neutrals[Ⓢ], like standard main lugs, are also rated for copper or aluminum wire. The neutral cross bar material follows the selection bus. Copper neutral lugs are rated for copper cable only and available as a price added option.

Lug Data Feed-Thru Lugs

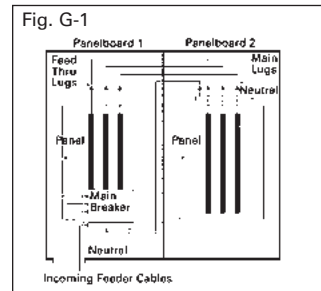

Subfeed Lugs or Double Lug

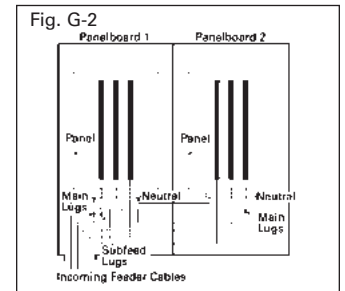

Feed-thru lugs (fig. G-1) are mounted at the opposite end of the main bus from the main lugs or main breaker and are used to connect two or more panelboards to the incoming feeder. The feeder cables are brought into Panelboard 1 and connected to the main lugs or main breaker. Cables interconnecting the two panelboards are connected to the feed-thru lugs in Panelboard 1 and are carried over the main lugs in Panelboard 2. This arrangement could be reversed with the main lugs located at the top and the feed-thru lugs at the bottom of the panel.

Subfeed lugs (fig. G-2) are mounted directly beside the main incoming lugs and are used to connect two or more panelboards to the incoming feeder. The feeder cables are brought into Panelboard 1 and connected to the main lugs. Another set of cables that are the same size are connected to the subfeed lugs of Panelboard 1 and are carried over the main lugs of Panelboard 2.

Note: P1 panelboards do not have subfeed lugs available. If this configuration is needed, move to a P2 or P3 panelboard.

Note: For Panelboards, Siemens uses this Document for the Operations and Maintenance manual: ANSI/NEMA PB 1.1-2013 [General Instructions for Proper Installation, Operation, and Maintenance of Panelboards Rated 600 Volts and Less (O&M Manual)] ** The PDF of this document can be downloaded (at no cost) for printing at this location: <https://www.nema.org/standards/view/Panelboards> (ref. Material # 11-1056-01)

[Ⓢ] Reference info: Neutral Lugs are rated for 75°C cable. When running a circuit to a load, the same type of wire should be used on the phase (breaker) and neutral connections in the panel.

a) Cables should be sized per NEC Table 310.16 (formerly Table 310.15(B)(16)) and the 75°C column.

b) Customer can choose to use 90°C cable if sized as if it is 75°C.

c) Some 100% rated circuit breakers require the use of 90°C cable sized per the 75°C column. Refer to the Markings on the breaker and use the appropriate cable.

d) Some Circuit breakers 100A or less are marked as being suitable for 60°C, 75°C or 60/75°C cable. Refer to the Markings on the breaker and use the appropriate cable.

Panelboards

General Specifications

General

Bussing Sequence

Interiors are designed to accommodate top or bottom feed. Regardless of which is specified, the uppermost pole is always on "A" phase; the second pole down is always on "B" phase, and the third pole down is always on "C" phase (assuming 3-phase voltage system).

As standard, branch breakers shall be mounted at the top of the panel with "spaces" at the bottom, regardless of the direction from which the panel is fed.

All breakers have bolted connections. The panel design provides bracing up to 200,000A IR CSA short circuit rating.

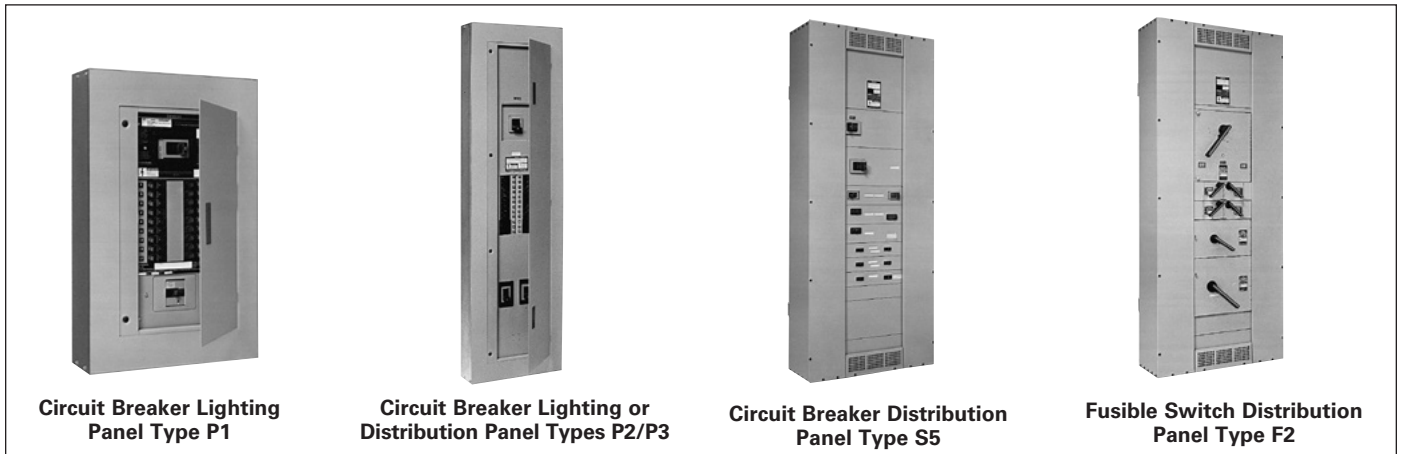

Panelboard Ratings

Description	Revised P1	P2	P3	S5	F2
Max. Voltage	600Y/347V AC Max.⑦	600V AC Max. 250V DC Max.	600V AC Max. 250V DC Max.	600V AC Max. 250V DC Max.	600V AC Max. 250V DC Max.
System	1-Phase, 2-wire 1-Phase, 3-wire 3-Phase, 3-wire 3-Phase, 4-wire	1-Phase, 2-wire 1-Phase, 3-wire 3-Phase, 3-wire 3-Phase, 4-wire	1-Phase, 2-wire 1-Phase, 3-wire 3-Phase, 4-wire 3-Phase, 3-wire	1-Phase, 3-wire 3-Phase, 4-wire 3-Phase, 3-wire	1-Phase, 3-wire 3-Phase, 4-wire 3-Phase, 3-wire
Mains					
Main Lugs	125A-400A	125A-600A	400A-800A	225A-1200A	225A-1200A
Main Breaker	100A-400A	100A-600A	200A-600A	400A-1200A	—
Main Switch	—	—	—	—	200A-600A
Circuits	18, 30, 42, 54, 66 (250A) 30, 42, 54, 66 (400A)	18, 30, 42, 54, 66 78, 90⑧	18, 30, 42, 54, 66, 78, 90	—	—
Branch Ratings	15-125A (Interior) 250A Max. (Subfeed breaker)	15-250A (Interior) 250A Max. (Subfeed breaker)	15-250A (Interior) 400A Max. (Subfeed breaker)	15-1200A MCCB	30-1200A Fusible
Branch Disconnect Devices	BL/BQD series, BT series, xGB series, 3VA41 series⑨, AFCI/GFCI series,	BL/BQD series, BT series, xGB series, 3VA41 series, QR series⑩, 3VA52/61/62 series⑩, AFCI/GFCI series, ED series,	BL/BQD series, BT series, xGB series, 3VA41 series, QR series⑩, 3VA52/61/62 series⑩, AFCI/GFCI series, ED series,	All 15-1200A MCCBs, and VL DG, FG, JG	All 30-600A VB switches, 30-200A VK switches, and 800-1200A HCP switches
Subfeed Circuit Breakers⑩⑪	ED series, QR series, FD series, 3VA41 series 3VA52/61/62 series - coming soon	FD series, JD series, 3VA53/63 series	FD series, JD series, 3VA53/63 series	—	—
Enclosure Heights Inches – (mm)	26, 32, 38, 44, 50, 56 @250A (660, 813, 965, 1118, 1270, 1422) 56, 62, 68, 74 @400A (1422, 1575, 1727, 1880)	26, 32, 38, 44, 50, 56, 62, 68, 74 (660, 813, 965, 1118, 1270, 1422, 1524, 1575, 1727)	56, 62, 68, 74, 80 (1422-2032)	60, 75, 90 (1524, 1905, 2286)	60, 75, 90 (1524, 1905, 2286)
Standard Trims	Fas-Latch – 1 Piece Surface or Flush	Fas-Latch – 1 Piece Surface or Flush	Fas-Latch – 1 Piece Surface or Flush	—	—

① Functional pricing is based on circuits shown. However, the panel can be configured with less circuits.

② P1 can have max. 1 subfeed breaker when Subfeed Space is available. P2 and P3 can have up to (2) FD subfeed breakers.

③ JD and FD breakers are mounted vertical. Limitations apply.

④ A maximum of (4) QR/3VA52/3VA61/3VA62 may be installed in a P2 panel and are single mounted in a 20" w enclosure.

⑤ A maximum of (6) QR/3VA52/3VA61/3VA62 may be installed in a P3 panel and are twin mounted.

⑥ P1 panels with xGB/3VA41 are limited to interiors for xGB/3VA41 breakers only.

⑦ Factory assembled P1 has capability of 600Y/347V AC system when the proper breakers are selected.

Panelboards

General Specifications

General

Typical Panelboard Modifications

Description	Lighting and Distribution Panelboards			Distribution Panelboards	
	P1	P2	P3	S5	F2
Box					
Type 1	Standard (20" W)	Standard (20" W)	Standard (24" W)	Standard	Standard
Type 1 Enclosure with Hood (available from distributor stock)	☐	☐	☐	☐	☐
Type 1 w/Gasket between box and front	☐	☐	☐	☐	☐
Type 2 Enclosure - Drip Tight [Ⓞ]	☐	☐	☐	☐	☐
Type 3R/12	☐	☐	☐	☐	☐
Type 4, 4X (size varies by type/material)	☐	☐	☐	—	—
Wider Box (check w/factory for custom options)	☐ (24"W)	☐ (24", 30" or 36"W)	☐ (30" or 36"W)	☐ (custom)	☐ (custom)
Deeper Box (check w/factory for custom options)	(7.75"D)	☐ (7.75"D)	☐ (custom)	☐ (custom)	☐ (custom)
Front					
Front with Door	Standard	Standard	Standard	☐	☐
4-piece Front	—	—	—	Standard	Standard
4-piece Front w/Hinged Gutter Covers	—	—	—	☐	☐
Hinged-to-Box Front/Skew-to-Box Front	☐	☐	☐	(see Door-in-Door)	(see Door-in-Door)
Door-in-Door Front	☐	☐	☐	☐	☐
Door with padlock	☐	☐	☐	—	—
Special Locks	☐	☐	☐	☐	☐
Nameplate	☐	☐	☐	☐	☐
Interior					
Aluminum Equipment Ground Bar	Standard	Standard	Standard	Standard	Standard
Copper Equipment Ground Bar	☐	☐	☐	☐	☐
Insulated Equipment Ground (CU or AL)	☐	☐	☐	☐	☐
Subfeed Lugs	—	☐	☐	☐	☐
Feed-Thru Lugs	☐	☐	☐	☐	☐
Compression Lugs	☐	☐	☐	☐	☐
Copper Lugs	☐	☐	☐	☐	☐
200% Neutral	☐	☐	☐	400 - 600A	400 - 600A
Tin Plated Aluminum Bussing	Standard	Standard	Standard	Standard	Standard
Tin Plated Copper Bussing	☐	☐	☐	☐	☐
Silver Plated Copper Bussing	—	☐	☐	☐	☐
R, J and T Fuse Clips	—	—	—	—	☐

☐ Available as an option. — Not Available

Ⓞ To meet sprinkler proof requirements, if required:
 - P1/P2/P3 Panels:
 - Select Type 2 enclosure for non-service entrance applications.
 - Select Type 3R enclosure for service entrance applications.
 - S5/F2 Panels:
 - Select Type 3R enclosure.

Panelboards

Factory Assembled

Selection

Catalogue Numbering System



Type of Panel P1, P2, P3, S5, F2

Voltage and System*

- | | |
|--|---|
| C = 208Y/120 3Ø 4 W Wye AC - All | R = 415/240 3Ø 4 W Wye AC - All |
| E = 480Y/277 3Ø 4 W Wye AC - All | S = 440/250 3Ø 4 W Wye AC - All |
| D = 240 3Ø 3 W Delta AC - All | L = 600/347 3Ø 4 W Wye AC - All |
| F = 480 3Ø 3 W Delta AC - All | T = 230 3Ø 3 W Delta AC - All |
| G = 600 3Ø 3 W Delta AC - P2, P3, S5, F2 | W = 380 3Ø 3 W Delta AC - P2, P3, S5, F2 |
| I = 347 3Ø 3 W Delta AC P2, P3, S5, F2 | 1 = 24V DC 1-Pole Branch Only - P2, P3, S5, F2 |
| B = 240/120 3Ø 4 W Delta BØ High Leg AC - P2, P3, S5, F2 | 2 = 24V DC 2-Pole Branch Only - P2, P3, P4, P5 |
| Q = 240/120 3Ø 4 W Delta CØ High Leg AC - P2, P3, S5, F2 | 3 = 48V DC 1-Pole Branch Only - P2, P3, S5, F2 |
| A = 120/240 1Ø 3 W Grounded Neutral AC - All | 4 = 48V DC 2-Pole Branch Only - P2, P3, S5, F2 |
| H = 120 1Ø 2 W Grounded Neutral AC - P2, P3, S5, F2 | 5 = 125V DC 1-Pole Branch Only - P2, P3, S5, F2 |
| J = 240 1Ø 2 W No Neutral AC - All | N = 125V DC 2-Pole Branch Only - P2, P3, S5, F2 |
| Y = 125 1Ø 2 W Grounded Neutral AC - P2, P3, S5, F2 | O = 125/250V DC 2-Pole Branch Only - P2, P3, S5, F2 |
| Z = No Longer Available | P = 125/250V DC 2 & 3-Pole Branch - All |
| K = 220/127 3Ø 4 W Wye AC - All | U = 120V AC 3Ø3W - All |
| M = 380/220 3Ø 4 W Wye AC - All | V = 240V 3Ø3W Grounded B Phase - P2, P3, S5, F2 |

*For any voltage system not listed, check with sales for availability.

Circuits

- P1 - 18, 30, 42, 54, 66
 P2 - 18, 30, 42, 54, 66, 78, 90
 P3 - 18, 30, 42, 54, 66, 78, 90

Enclosure Height

- S5, F2 - 60, 75, 90

Main Lug (ML), Main Breaker

(See Main Breaker Table coding below)

Amperage

- 100-400A = P1[®] 400-800A = P3
 100-600A = P2 400-1200A = S5, F2

Bus Code^① Bus Material

- A Aluminum
 C Copper
 E Copper

Bus Plating

- Tin-Plated
 Tin-Plated
 Silver-Plated

P1

- optional

P2

- optional

P3

- optional

S5

- n/a

F2

- Indicates default for this bus type.

Feed Location

- T = Top B = Bottom

Mounting

- S = Surface
 F = Flush. Flush trims extend 1 1/2" beyond the base box dimensions on P1, P2 and P3.

Subfeed Space Indicator (for P1 only)

- T = Subfeed Space Included N[®] = No Subfeed Space

Branch Breaker Type

- NONE = BL/BOD type NGB = NGB/3VA41 type only^②

Main Breaker Coding

Code	Breaker	Code	Breaker	Code	Breaker	Code	Breaker	Code	Breaker	3VA ref	Code	Breaker	3VA ref
BL	BL	CJ	CJD6	L6	LD6	HN	HND6	V1	SEAB	3VA41	W2	MDAE	3VA61
BH	BLH	6H	HHJD6	LX	LXD6	HT	HNXD6	V2	MEAB	125A	W3	HDAE	150A
BR	BLR	H9	HHJD6	LH	LXD6H	HX	HNXD6H	V3	HEAB	max	W4	CDAE	max
HB	HBL	H6	HJD6	S1	SCLD6	ND	ND6	V4	SEAS	3VA51	W5	LDAE	150A
BQ	BQD	H5	HJXD6	S2	SHLD6	NX	NXD6	V5	MEAS	max	WA	MFAE	250A
B6	BQD6 ^③	H7	HJXD6H	SL	SLD6	NT	NXD6H	V6	HEAS	max	WB	HFAE	max
CE	CED6	J6	JD6	—	—	SR	SCND6	VA	MFAS	3VA52	WC	CFAE	max
E4	ED4	JD	JXD2	—	—	ST	SCND6H	VB	HFAS	250A	WD	LFAE	max
E6	ED6	JX	JXD6	—	—	AD	SHND6	VC	CFAS	max	WE	MJAE	3VA63
H4	HED4	JH	JXD6H	C9	CMD6	SD	SHND6H	VE	MJAS	3VA53	WF	HJAE	400A
HA	HHED6	SC	SCJD6	CH	CMD6H	SN	SND6	VF	HJAS	400A	WG	CJAE	max
CF	CFD6	SX	SHJD6	HM	HMD6	AY	SND6H	VG	CJAS	max	WH	LJAE	max
FD	FD6	SY	SHJD6H	HR	HMXD6	—	—	VJ	MLAS	3VA54	WJ	MLAE	3VA64
FX	FXD6	SJ	SJD6	HS	HMXD6H	—	—	VK	HLAS	600A	WK	HLAE	600A
HF	HFD6	SH	SJD6H	MD	MD6	—	—	VL	CLAS	max	WL	CLAE	max
H2	HFXD6	CL	CLD6	MX	MXD6	—	—	VN	MMAS	3VA55	WM	LLAE	800A
H1	HHFD6	HH	HHLD6	MH	MXD6H	—	—	VO	HMAS	max	WN	MMAE	max
H3	HHFXD6	XH	HHLXD6	SO	SCMD6	—	—	VP	CMAS	max	WO	HMAE	max
G2	HGB	HL	HLD6	SO	SCMD6H	—	—	VV	MNAS	3VA57	WP	CMAE	max
G3	LGB	HO	HLXD6	S5	SHMD6	—	—	VW	HNAS	1200A	WR	MMNAE	3VA66
NB	NGB	HP	HLXD6H	S6	SHMD6H	—	—	VX	CNAS	max	WS	HMNAE	1000A
G4	NGB2	—	—	SM	SMD6	—	—	—	—	—	WT	CMNAE	max
G5	HGB2	—	—	AX	SMD6H	—	—	—	—	—	WV	MNAE	3VA67
G6	LGB2	—	—	CN	CND6	—	—	—	—	—	WW	HNAE	1200A
—	—	—	—	C6	CND6H	—	—	—	—	—	WX	CNAE	max

① Standard bussing in P1, P2 and P3 panels is tin-plated for aluminum and copper.

② Not available for Revised P1 NGB/3VA41 interiors.

③ P1 Bus is either 250A max or 400A max.

④ 3VA41 breakers can only be used in interiors manufactured after October 2020 and marked with the NGB suffix.

⑤ Not available for Revised P1 xGB interiors.

Panelboards

Distributor stock - Type P1 Ready To Assemble Panelboards

Reference

Type P1 ready to assemble panelboards are completely convertible from main lug to main breaker and vice-versa. Additionally, feed-thru lugs up to 400A or sub-feed circuit breakers up to 250A can be added without increasing the box height for Revised P1 with "T" suffix, see the chart.

1. Compute total number of poles to determine interior catalog number. (Note: BL / BQD (or) or 3VA41/xGB Main Breaker will use unit space. The total number of poles should include 2 or 3 poles for 1-phase or 3-phase mains.
2. List catalog number of interior, box and front.
3. Select main lug kit or main breaker

kit from appropriate tables.

Note: Main/Subfeed Breaker mounting kits may be ordered with or without breakers included, see page 10-13 and 10-14 for selection.

4. List required branch circuit breakers and filler plates to cover any unused positions.
5. Select any modifications or accessories.

Note: Revised P1 was introduced in June 2015. All original P1 devices do not include the "Subfeed Space" Indicator. All original P1 included the Subfeed Space as standard.

Type of Panel _____

P1

Voltage and System _____

C = 208Y/120, 3-Phase 4-Wire
 A = 120/240V, 1-Phase 3-Wire
 L = 600Y/347V, 3-Phase 4-Wire

Circuits _____

18, 30, 42, 54* (*Revised P1 only)

Mains _____

ML = Main lugs
 MC = Main convertible
 Select Main Lug Kit or Breaker Mounting Kit from pages 10-12 or 10-13

Amperage _____

250A max or 400A max only (typically 250A max Bus (or) 400A max Bus^①)

Main Bus Material _____

A = Aluminum
 C = Copper

Subfeed Space Indicator (for Nex Gen P1 only) T = Subfeed Space Included

Note: Standard bussing in P1 panels is tin plated for aluminum and copper. Standard bus is rated to the maximum amperage in the panel.

Branch Breaker Type _____

NONE = BL/BQD type NGB = NGB/3VA41 type only^②



Branch Breakers

Revised P1 Branch Breaker Reference						
Panel Type	Voltage Reference	Breaker Frame (kA Range)				
		BL	BQD	BQD6	NGB	3VA41
Revised P1	120/240V	10-65kA	65kA	65kA	100kA	65-150kA
	240V	10-65kA	65kA	65kA	100kA	65-150kA
	480/277V	—	14kA	10kA	25kA	25-65kA
	480V	—	—	—	—	25-65kA
	600/347V	—	—	10kA	14kA	14-25kA
Revised P1 Interior Type						
P1C	208Y/120, 3-Phase 4-Wire	✓	✓	✓	✓	✓
P1A	120/240V, 1-Phase 3-Wire	✓	✓			
P1L	600Y/347V, 3-Phase 4-Wire			✓		
P1L (NGB) Manufactured prior to October 2020	600Y/347V, 3-Phase 4-Wire				✓	
P1L (NGB) Manufactured after October 2020	600Y/347V, 3-Phase 4-Wire				✓	✓

① P1 panels use either 250A rated bus or 400A rated bus, regardless of the Main Breaker installed (or) MLO Amp rating chosen. Panels with 250A bus can have up to 250A Main Breaker or Main Lugs. Panels with 400A bus can have up to 400A Main Breaker or Main Lugs.
 ② 3VA41 breakers can only be used in interiors manufactured after October 2020 and marked with the NGB suffix.

Panelboards

Features / Benefits

Reference

The standard Siemens P1 panelboard has some unique features that make it easier to design for an engineer, easier to reconfigure in the field for a contractor, and easier to upgrade and maintain for the Owner.

- The P1 is the smallest panel in the Siemens lineup, with bus sizes up to 400A.
- What makes it different is the split neutral design and the open ended bus. In the Siemens panel, instead of the common single neutral bus on one end, we have a neutral bus on both sides that is cross-bussed.
- This makes branch wiring simpler and cleaner – the lead lengths for line and neutral can now be made nearly the same, creating more room and a neater installation.
- It also allows access to both ends of the bus as a standard feature – this provides the flexibility to make changes in the field, even if it wasn't part of the original configuration. Revised P1 introduced in 2015 has extended circuits up to 66 available and also non-feed thru versions are available, without the Subfeed Space, in a 6" smaller enclosure.
- Starting with 2022, new breakers were introduced: BT twin, and 3VA41/52/61/62 as branch breakers and BSPD surge products

MAIN BREAKER or SUB-FEED BREAKER

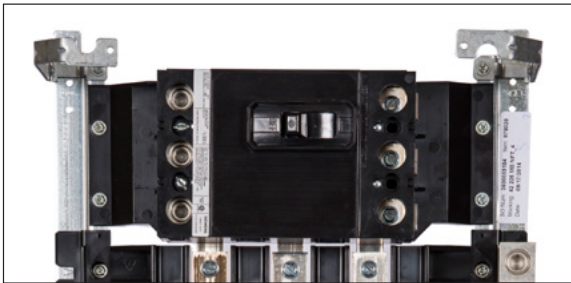

MAIN LUGS or FEED-THROUGH LUGS



INTEGRAL BUS MOUNTED SPD

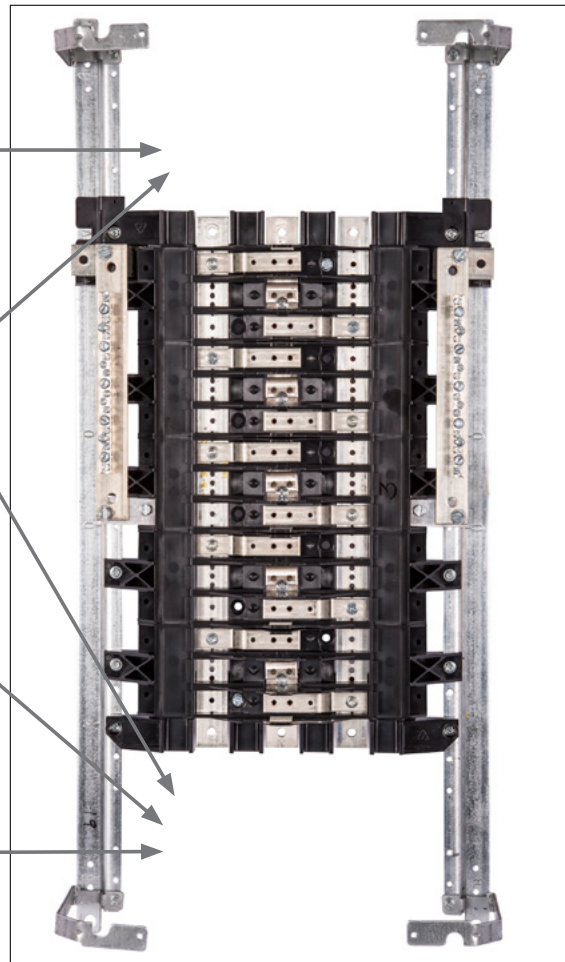

The following can be done to a standard P1 panelboard **in the field** with no modifications:

- Change from top fed to bottom fed
- Add feed-through lugs^①
- Add an Integral bus-mounted SPD^① ^{①⑤⑧} the new branch mounted BSPDs
- Add a sub feed breaker up to 250 amps^①
- Change from Main Lugs to Main Breaker
- Change from Main Breaker to Main Lugs
- Panel may have up to two ground assemblies. Options are: (a) standard aluminum, (b) optional copper, or (c) optional insulated/ isolated aluminum or copper. Mounting provisions in opposing corners of the box are standard. Any of these options may be added after installation.

^① Only when Subfeed Space is selected/available.

Panelboards

Distributor stock - Type P1 Ready To Assemble Panelboards

To better serve the needs of customers, Ready to Assemble Panelboards offer product flexibility, quicker job turn-around, and affordable pricing. All Siemens ready to assemble panelboards are fully backed for high quality, and trouble-free operation.

Flexibility and ease of assembly:

Customer oriented design creates installation convenience. For all of its one-of-a-kind features, the P1 panelboard is also designed to be extremely user friendly. For instance, field convertible main breaker and main lug kits, (through 400 amps), will allow you to switch from main lug to main breaker, and vice versa with no change in box size or additional cabling. Plus, lay-in construction (for 250 A CU) and/or removable lugs make wiring the main and neutral lugs easier and faster.

To further speed wiring, as well as reduce clutter, the P1 panel also features a split neutral design and branch neutral connections which are closer to the breakers than competitors. Additionally, field addable sub-fed breakers (up to 250 amps) or feed through lug kits can be field installed without utilizing any of your feeder breaker positions or increasing your box height. Furthermore, the unique design allows the panel to be inverted in the field and keep its labeling legible.

- 1) Completely symmetrical Type 1 boxes may be mounted with either end up. There are two pre-punched equipment ground connector locations for contractor friendly installation.
- 2) Box comes pre-punched for optional, field installable door-in-door or hinged style trims. There are also two pre-punched ground connector locations. The panel box will accept both standard ground connector (EGK and ECGK) assemblies and insulated ground connector kits (IGK and ICGK).
- 3) Interior mounting is completely symmetrical allowing it to be changed from top to bottom feed by simply rotating the interior.
- 4) Choose either a Main Breaker kit or Main Lug kit with which to terminate your incoming cables. Main lug kits are contractor friendly lugs through 350 kcmil (250 amp panel), (1) 600 kcmil or (2) 250 kcmil connectors for 400 amp panels. No line connectors in the P1 panel require multiple wires under one screw. Main Breaker kits (250 amps and below) are horizontally mounted allowing field convertible top or bottom feeds to be performed easily. MLO kits and Main Breaker Kits are interchangeable and can be changed/added in the field without making changes to the enclosure or interior.
- 5) Branch neutral connections are near the breaker connections to speed wiring and reduce clutter. The standard P1 neutral is rated for 100% of the panel's ampacity and will accept copper or aluminum wire. Optional 200% and 2/0 neutral kits are also available. (2/0 max. Neutral strips are now standard on all NGB/3VA41 Interiors.)
- 6) The panel includes space to add (1) sub-feed breaker (max 250 amps), feed-thru lugs or one TPS3 or TPS4 (SPD) kit. Branch mounted BSPDs are also available for Surge Protection Flexibility.
- 7) Siemens standard trim has hidden hinges and mounting hardware for added safety. The rounded door corners not only enhance the panel's appearance but also help to eliminate injuries caused from sharp corners.
- 8) Semi-flush lock comes standard. Easily identified locked position denoted by keyway being horizontal when door has been locked.

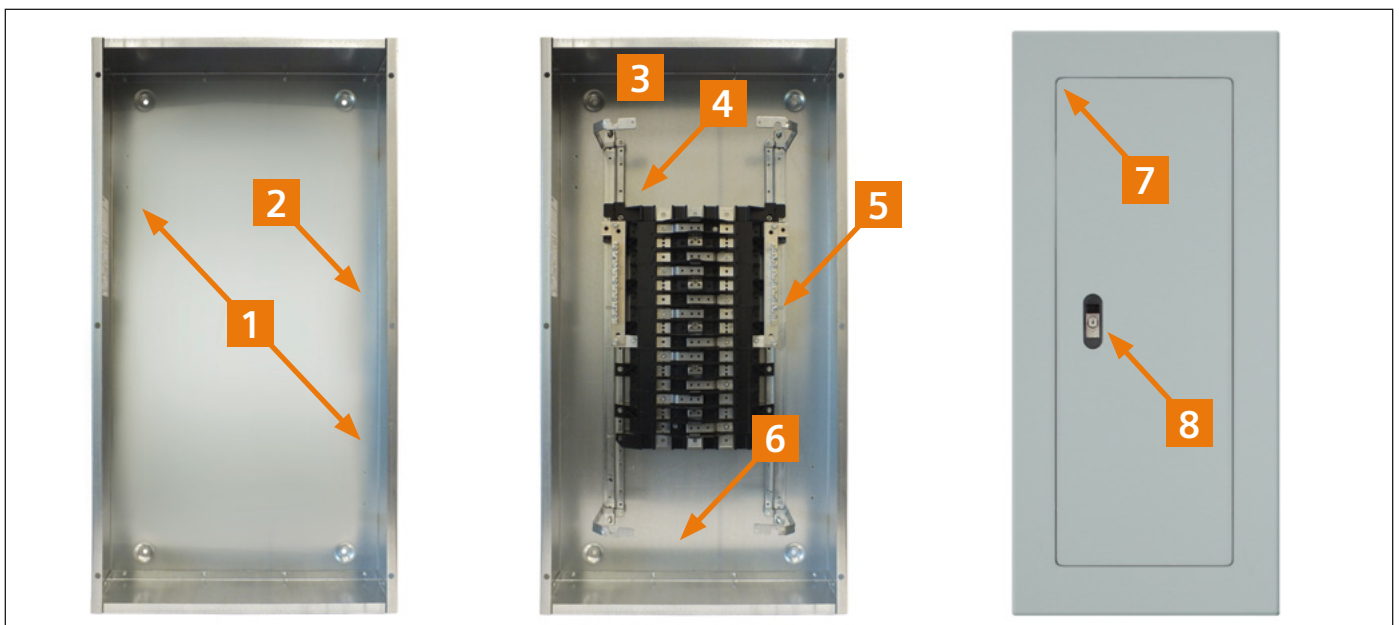

Panelboards

Revised P1 Panelboard 250 & 400A

Reference

Invertibility and Flexibility

All FT and NFT are invertible in field – Top-feed or Bottom-feed

FT Feed-Thru Style Panel (Catalog Number ends with "T")^①

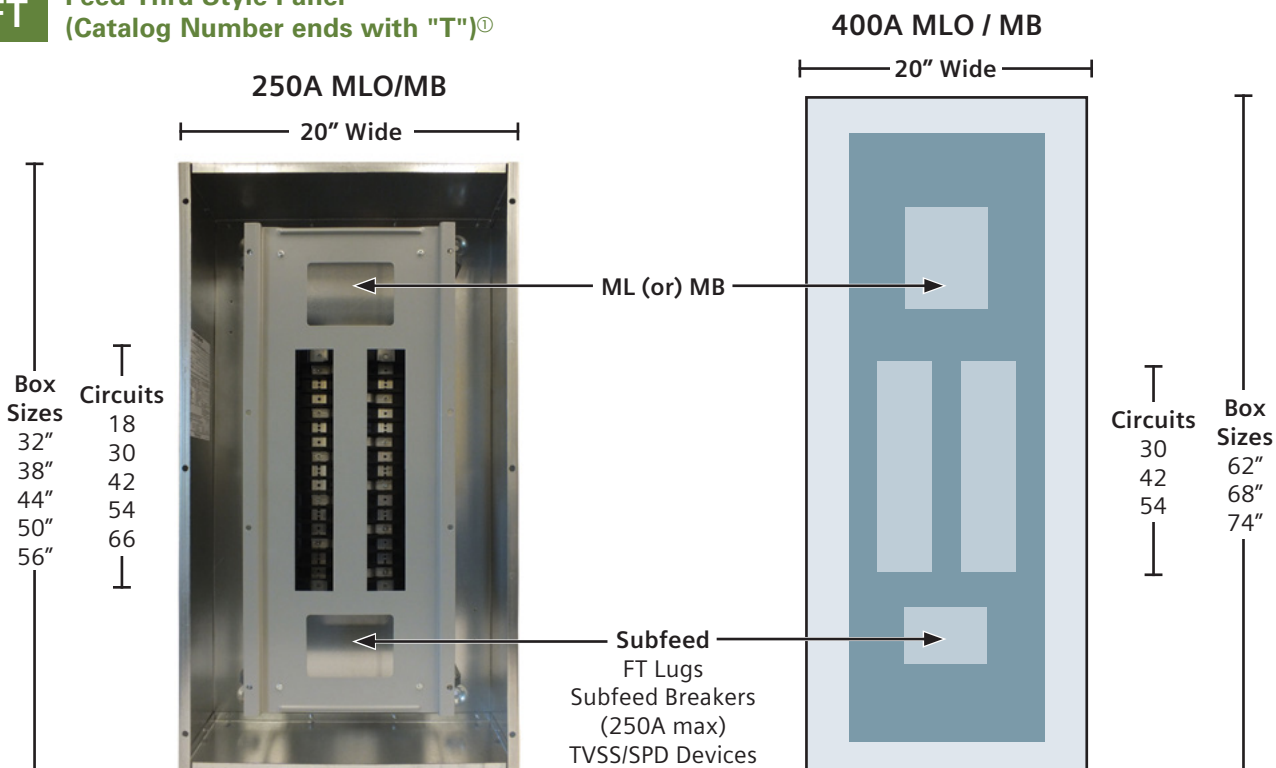

NFT Non-Feed-Thru Style Panel (Catalog Number ends with "N")^②

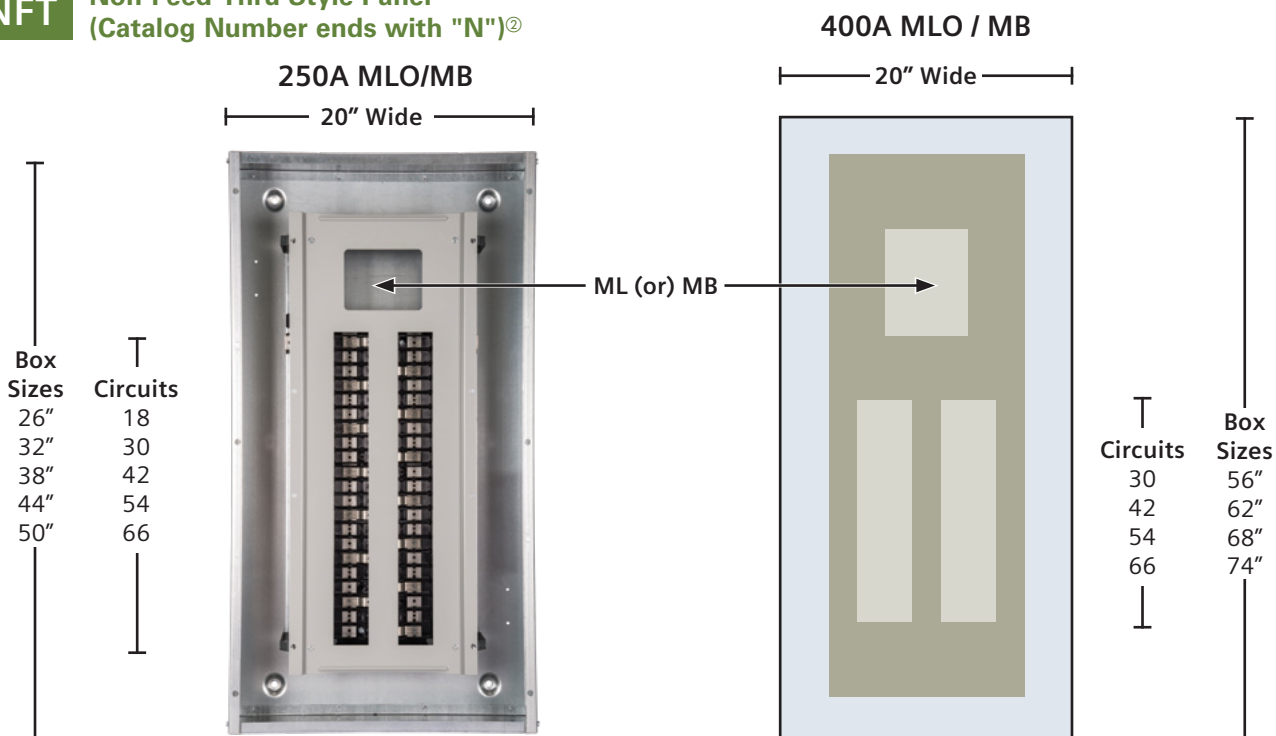

^① 66 circuits only for Factory Assembly.

^② Not available for stock or Ready to Assemble Panelboards

Panelboards

Revised P1 Panelboard 250A and 400A

Reference

Revised P1 Panelboard 250A and 400A

FT 250A Configurations Feed-Thru Style Panel

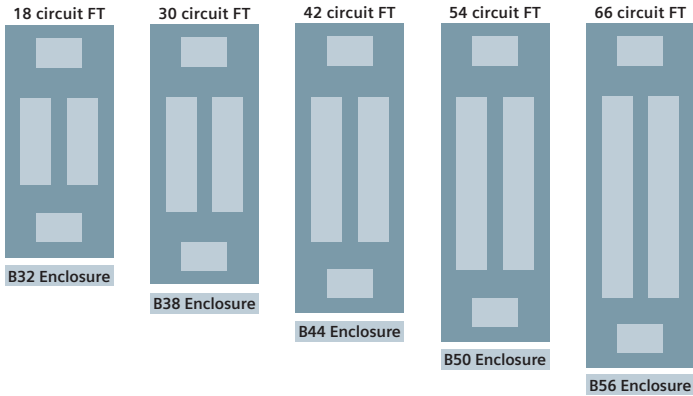

NFT configurations below are
6" shorter than FT with same circuit count

FT 400A Configurations Feed-Thru Style Panel

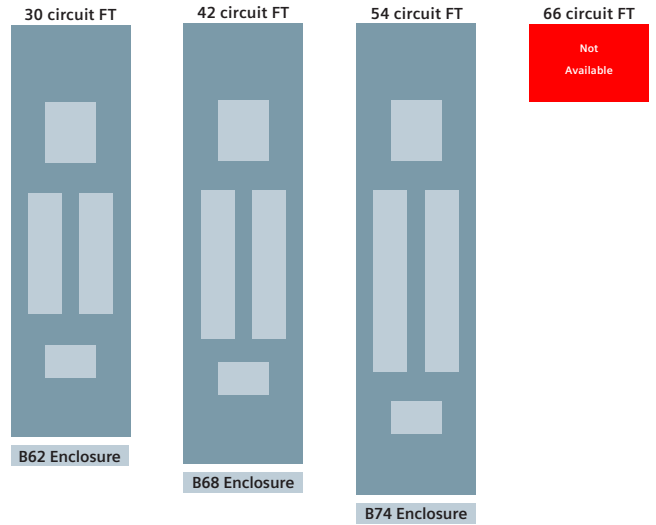

NFT 250A Configurations Non Feed-Thru Style Panel

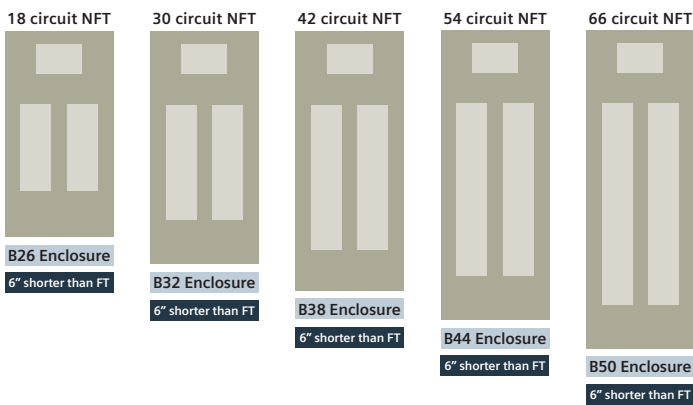

NFT 400A Configurations Non Feed-Thru Style Panel

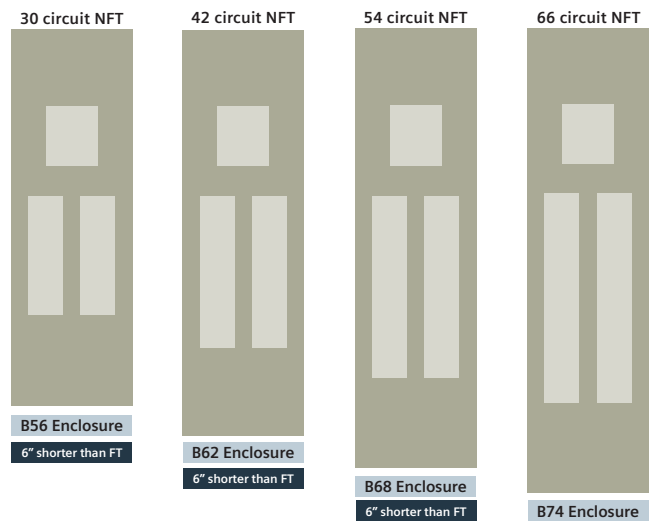

Panelboards

Distributor Stock - Type P1 Ready To Assemble Panelboards

Reference

400A Max. — 20" Wide x 5.75" Deep

1. Choose the appropriate Interior from the table below.
2. Choose the Main Device: Main Lugs from page 10-13, Main Breaker Kit from pages 10-13 - 10-14.
3. Choose Branch Breakers. BL, BQD and NGB/3VA41 breakers from pages 10-16 - 10-19.
4. Choose Feed-Thru Lugs or Subfeed Breaker Kit from page 10-13.

Type P1 Into Stock Panelboards (Revised P1 introduced in June 2015)

Amps	Max. # of Poles	Revised P1 Main Lug Interior Cat. Number	Revised P1 Main Convertible Interior Cat. Number	Box Size	Type 1 Encl.	Type 3R/12 Encl.①	Type 1 Front Surface	Type 1 Front Flush
1-Phase, 3-Wire 120/240V (BL/BQD Branch Breakers only)								
250	18	P1A18ML250AT	P1A18MC250AT	32	B32	WP32	S32B	F32B
	30	P1A30ML250AT	P1A30MC250AT	38	B38	WP38	S38B	F38B
	42	P1A42ML250AT	P1A42MC250AT	44	B44	WP44	S44B	F44B
	54	P1A54ML250AT	P1A54MC250AT	50	B50	WP50	S50B	F50B
400	18	—	—	—	—	—	—	—
	30	P1A30ML400AT	P1A30MC400AT	62	B62	WP62	S62B	F62B
	42	P1A42ML400AT	P1A42MC400AT	68	B68	WP68	S68B	F68B
	54	P1A54ML400AT	P1A54MC400AT	74	B74	WP74	S74B	F74B
250	18	P1A18ML250CT	P1A18MC250CT	32	B32	WP32	S32B	F32B
	30	P1A30ML250CT	P1A30MC250CT	38	B38	WP38	S38B	F38B
	42	P1A42ML250CT	P1A42MC250CT	44	B44	WP44	S44B	F44B
	54	P1A54ML250CT	P1A54MC250CT	50	B50	WP50	S50B	F50B
400	18	—	—	—	—	—	—	—
	30	P1A30ML400CT	P1A30MC400CT	62	B62	WP62	S62B	F62B
	42	P1A42ML400CT	P1A42MC400CT	68	B68	WP68	S68B	F68B
	54	P1A54ML400CT	P1A54MC400CT	74	B74	WP74	S74B	F74B
3-Phase, 4-Wire 208Y/120V (BL/BQD Branch Breakers only)								
250	18	P1C18ML250AT	P1C18MC250AT	32	B32	WP32	S32B	F32B
	30	P1C30ML250AT	P1C30MC250AT	38	B38	WP38	S38B	F38B
	42	P1C42ML250AT	P1C42MC250AT	44	B44	WP44	S44B	F44B
	54	P1C54ML250AT	P1C54MC250AT	50	B50	WP50	S50B	F50B
400	18	—	—	—	—	—	—	—
	30	P1C30ML400AT	P1C30MC400AT	62	B62	WP62	S62B	F62B
	42	P1C42ML400AT	P1C42MC400AT	68	B68	WP68	S68B	F68B
	54	P1C54ML400AT	P1C54MC400AT	74	B74	WP74	S74B	F74B
250	18	P1C18ML250CT	P1C18MC250CT	32	B32	WP32	S32B	F32B
	30	P1C30ML250CT	P1C30MC250CT	38	B38	WP38	S38B	F38B
	42	P1C42ML250CT	P1C42MC250CT	44	B44	WP44	S44B	F44B
	54	P1C54ML250CT	P1C54MC250CT	50	B50	WP50	S50B	F50B
400	18	—	—	—	—	—	—	—
	30	P1C30ML400CT	P1C30MC400CT	62	B62	WP62	S62B	F62B
	42	P1C42ML400CT	P1C42MC400CT	68	B68	WP68	S68B	F68B
	54	P1C54ML400CT	P1C54MC400CT	74	B74	WP74	S74B	F74B
3-Phase, 4-Wire 600Y/347V (BQD6 Branch Breakers only)								
250	18	P1L18ML250AT	P1L18MC250AT	32	B32	WP32	S32B	F32B
	30	P1L30ML250AT	P1L30MC250AT	38	B38	WP38	S38B	F38B
	42	P1L42ML250AT	P1L42MC250AT	44	B44	WP44	S44B	F44B
	54	P1L54ML250AT	P1L54MC250AT	50	B50	WP50	S50B	F50B
400	18	—	—	—	—	—	—	—
	30	P1L30ML400AT	P1L30MC400AT	62	B62	WP62	S62B	F62B
	42	P1L42ML400AT	P1L42MC400AT	68	B68	WP68	S68B	F68B
	54	P1L54ML400AT	P1L54MC400AT	74	B74	WP74	S74B	F74B
250	18	P1L18ML250CT	P1L18MC250CT	32	B32	WP32	S32B	F32B
	30	P1L30ML250CT	P1L30MC250CT	38	B38	WP38	S38B	F38B
	42	P1L42ML250CT	P1L42MC250CT	44	B44	WP44	S44B	F44B
	54	P1L54ML250CT	P1L54MC250CT	50	B50	WP50	S50B	F50B
400	18	—	—	—	—	—	—	—
	30	P1L30ML400CT	P1L30MC400CT	62	B62	WP62	S62B	F62B
	42	P1L42ML400CT	P1L42MC400CT	68	B68	WP68	S68B	F68B
	54	P1L54ML400CT	P1L54MC400CT	74	B74	WP74	S74B	F74B
Interiors for NGB/3VA41 Breakers — 3-Phase, 4-Wire 600Y/347V (NGB/3VA41 Branch Breakers only)②								
250	18	P1L18ML250AT-NGB	P1L18MC250AT-NGB	32	B32	WP32	S32H	F32H
	30	P1L30ML250AT-NGB	P1L30MC250AT-NGB	38	B38	WP38	S38H	F38H
	42	P1L42ML250AT-NGB	P1L42MC250AT-NGB	44	B44	WP44	S44H	F44H
400	18	—	—	—	—	—	—	—
	30	P1L30ML400AT-NGB	P1L30MC400AT-NGB	62	B62	WP62	S62H	F62H
	42	P1L42ML400AT-NGB	P1L42MC400AT-NGB	68	B68	WP68	S68H	F68H
250	18	P1L18ML250CT-NGB	P1L18MC250CT-NGB	32	B32	WP32	S32H	F32H
	30	P1L30ML250CT-NGB	P1L30MC250CT-NGB	38	B38	WP38	S38H	F38H
	42	P1L42ML250CT-NGB	P1L42MC250CT-NGB	44	B44	WP44	S44H	F44H
400	18	—	—	—	—	—	—	—
	30	P1L30ML400CT-NGB	P1L30MC400CT-NGB	62	B62	WP62	S62H	F62H
	42	P1L42ML400CT-NGB	P1L42MC400CT-NGB	68	B68	WP68	S68H	F68H



42 circuit with Back-fed Main



54 circuit 400A

① Front included in type 3R/12 Box.

② 3VA41 breakers can only be used in interiors manufactured after October 2020 and marked with the NGB suffix.

Panelboards

Warehouse Stock – Type P1 Panelboards

Selection

Lug Kits – Main or Feed Thru

Amp Rating	Matl.	Wire Range (includes Neutral)	Service	Revised P1 [®] Cat. No.
250	AL	(1) #6 AWG- 350 kcmil (CU or AL)	1 Phase	MLKA1A
			3 Phase	MLKA3A
	CU	(1) #6 AWG- 350 kcmil (CU or AL)	1 Phase	MLKC1A
			3 Phase	MLKC3A
400	AL	(2) 1/0 - 250 kcmil or (1) #2 AWG-600 kcmil	1 Phase	4MLKA1A
			3 Phase	4MLKA3A
	CU	(2) 1/0 - 4/0 or (1) 1/0 - 600 kcmil	1 Phase	4MLKC1A
			3 Phase	4MLKC3A
400	AL	(1) AL 1/0-750 kcmil (2) AL/CU 250 kcmil max. [max.(1) 600 kcmil CU wire]	1 Phase	4MLKA1B
			3 Phase	4MLKA3B



MBKQJ3A



MBKFD3A

Main and Subfeed Strap Kits for Revised P1[®]

Group	Amps	Kit Catalog #	Description	Replaces	Comments
250A RP1 Main Strap Kits	125A max	MBKVA41A	RP1 1PH Main/SF kit BL/BQD/GB/3VA4 - Includes filler #DFFPVA41A	MBKBL1A [Ⓞ] MBKBC1NBA [Ⓞ]	New kits allow use of all 4 breaker types with included adapter (coming soon).
		MBKVA41B	RP1 3PH Main/SF kit BL/BQD/GB/3VA4 - Includes filler #DFFPVA41A	MBKBL3A [Ⓞ] MBKBC3NBA [Ⓞ]	
		MBKED1A MBKED3A	RP1 1PH Main/SF kit ED - 125A max RP1 3PH Main/SF kit ED - 125A max	none	Includes DF Filler #DFFPVA41A replacing #DFFPED01
		MBKQR1A MBKQR3A	RP1 1PH Main/SF kit QR - 225A max RP1 3PH Main/SF kit QR - 225A max	none	Includes DF Filler #MBKQRFK Although QR is rated 250A, it is limited to 225A in panelboards
	225A max	MBKFD1A MBKFD3A	RP1 1PH Main/SF kit FD - 250A max RP1 3PH Main/SF kit FD - 250A max	none	Includes DF Filler #DFFPFD01
		MBKVA5262A MBKVA5262B	RP1 1PH Main/SF kit 3VA52/61/62 - 250A max RP1 3PH Main/SF kit 3VA52/61/62 - 250A max	none	Includes DF Filler #DFFPVA5262A
	250A max	MBKBFA	RP1 Back-Fed Main in unit space kit for BL/BQD/GB.	none	Includes labeling required to field install properly. This kit takes branch spaces and reduces circuit count by 2 or 3 positions.
		MBKVA5363A	RP1 400A 3VA Main Strap kit, 1ph or 3ph, includes: DFFPVA5363A (Large) Filler	none	These new 400A kits include both small and large filler plates as needed.
		MBKJD3B	RP1 400A JD Strap kit 1ph/3ph 2-fillers, includes: DFFPJD02 (Large) and DFFPJD01 (Small) Filler	MBKJD1A [Ⓞ] MBKJD3A [Ⓞ]	
		MBKVA5363JD	RP1 400A JD to 3VA53/63 Retrofit kit 1ph/3ph – This kit will allow 3VA53/63 in old 400A RP1 only with small Deadfront opening – no access to breaker adjustments without removing Deadfront.	none	

Neutral Kits for Revised P1[®]

Group	Amps	Kit Catalog #	Description	Replaces [Ⓞ]	Circuits / details
1/0 Neutral Kits	250A & 400A	LNLK5X12A	RP1 1/0 NEUTRAL LUG KIT [(5x)1/0 + (12x) #6] - short 1/0 replacement neutral strip (17POS) (5.80" long) (Ref: 11-D-1810-01 strip)	na	2 strips per pack - replacement parts
		LNLK7X18A	RP1 1/0 NEUTRAL LUG KIT [(7x)1/0 + (18x) #6] - long 1/0 replacement neutral strip (25POS) (8.14" Long) (Ref: 11-D-1810-02 strip)	na	
2/0 Neutral Kits	250A & 400A	LNLK4X11B	RP1 & P3 2/0 NEUTRAL LUG KIT (15POS) - [(4x)2/0 + (11x) #6] - 2/0 max neutral strips (6.17" Long) (Ref: 11-D-1814-01 strip)	LNLK30A LNLK42A LNLK54A Revised P1 only	2 strips per pack - replacement parts
		LNLK6X17B	RP1 & P3 2/0 NEUTRAL LUG KIT (23POS) - [(5x)2/0 + (17x) #6] - 2/0 max neutral strips (8.67" Long) (Ref: 11-D-1814-02 strip)		
		LNLK7X20B	RP1 & P3 2/0 NEUTRAL LUG KIT (27POS) - [(7x)2/0 + (20x) #6] - 2/0 max neutral strips (9.92" Long) (Ref: 11-D-1814-03 strip)		
Copper Neutral Kits	250A	CNLK42B	RP1 CU NEUTRAL LUG KIT, 42B - 2 short & 2 long strips (17 & 25 pos) contains: CU neutral strips and CU riser extension, plus all hardware to replace standard neutrals. CU strips are 1/0 max. and require CU cable. The 250A CU body neutral lug assembly is included with this kit.	CNLK30A CNLK42A CNLK54A Revised P1 only	250A - 18, 30, 42
	250A & 400A	CNLK54B	RP1 CU NEUTRAL LUG KIT, 54B - 4 long strips (25 pos) contains: CU neutral strips and CU riser extension, plus all hardware to replace standard neutrals. CU strips are 1/0 max. and require CU cable. The 250A and 400A CU body neutral lug assembly is included with this kit.	CNLK30A CNLK42A CNLK54A Revised P1 only	all 400A - 30, 54, 66 250A - 54, 66
200% Neutral Kits	250A	2NLK42B	RP1 250A 200% NEUTRAL LUG KITS. Contains: CU neutral strips (2 short & 2 long strips (17 & 25 pos)), CU neutral extensions and an additional AL Line Lug (350kcmil), plus all hardware to replace standard neutrals. CU strips are 1/0 max. and require CU cable. (200% neutral kits require CU neutrals)	2NLK30A 2NLK42A 2NLK54A Revised P1 only	250A - 18, 30, 42
		2NLK54B	RP1 250A 200% NEUTRAL LUG KITS. Contains: CU neutral strips (4 long strips (25 pos)), CU neutral extensions and an additional AL Line Lug (350kcmil), plus all hardware to replace standard neutrals. CU strips are 1/0 max. and require CU cable. (200% neutral kits require CU neutrals)		
	400A	42NLK54B	RP1 400A 200% NEUTRAL LUG KIT contains: CU neutral strips (4 long strips (25 pos)), CU neutral extensions and an additional AL Line Lugs (600kcmil and 300kcmil), plus all hardware to replace standard neutrals. CU strips are 1/0 max. and require CU cable. (200% neutral kits require CU neutrals)	42NLK30A 42NLK42A 42NLK54A Revised P1 only	all 400A - 30, 54, 66

Ⓞ Parts will no longer be available after inventory is depleted. OK to use up inventory.
Ⓞ Revised P1 kits cannot be used with original P1. See page 10-15.

Ⓞ MBKBFA is available for Back-Fed Mains in unit space with BL/BQD/xGB/3VA41 breakers. Includes labeling required to field install properly.

Panelboards

Warehouse Stock – Type P1 Panelboards

Selection

Main Breaker Mounting Kits with Breakers for P1 Panels (250A and lower can be used as subfeed kits also)

Frame size Reference	Revised P1 Catalog No.	Description	Max IR (kA) at		
			240V	480V	600V
ED [Ⓞ] 3-ph 125A Max.	MBKED3100A	Kit w/3-pole ED4 100A breaker	65	18	—
	MBKED3125A	Kit w/3-pole ED4 125A breaker	65	18	—
QR 1-ph 225A Max.	MBKQR1125A	Kit w/2-pole QR2 125A breaker	10	—	—
	MBKQR1150A	Kit w/2-pole QR2 150A breaker	10	—	—
	MBKQR1175A	Kit w/2-pole QR2 175A breaker	10	—	—
	MBKQR1200A	Kit w/2-pole QR2 200A breaker	10	—	—
	MBKQR1225A	Kit w/2-pole QR2 225A breaker	10	—	—
HQR 1-ph 225A Max.	MBKQR1125HA	Kit w/2-pole HQR2 125A breaker	65	—	—
	MBKQR1150HA	Kit w/2-pole HQR2 150A breaker	65	—	—
	MBKQR1175HA	Kit w/2-pole HQR2 175A breaker	65	—	—
	MBKQR1200HA	Kit w/2-pole HQR2 200A breaker	65	—	—
	MBKQR1225HA	Kit w/2-pole HQR2 225A breaker	65	—	—
QR2 3-ph 225A Max.	MBKQR3125A	Kit w/3-pole QR2 125A breaker	10	—	—
	MBKQR3150A	Kit w/3-pole QR2 150A breaker	10	—	—
	MBKQR3175A	Kit w/3-pole QR2 175A breaker	10	—	—
	MBKQR3200A	Kit w/3-pole QR2 200A breaker	10	—	—
	MBKQR3225A	Kit w/3-pole QR2 225A breaker	10	—	—
HQR2 3-ph 225A Max.	MBKQR3125HA	Kit w/3-pole HQR2 125A breaker	65	—	—
	MBKQR3150HA	Kit w/3-pole HQR2 150A breaker	65	—	—
	MBKQR3175HA	Kit w/3-pole HQR2 175A breaker	65	—	—
	MBKQR3200HA	Kit w/3-pole HQR2 200A breaker	65	—	—
	MBKQR3225HA	Kit w/3-pole HQR2 225A breaker	65	—	—
3VA52 3-ph 250A Max.	MBKVAM3150A	RP1 150A MB kit, 35kA 3ph 3VA52, MFAS	85	35	18
	MBKVAM3200A	RP1 200A MB kit, 35kA 3ph 3VA52, MFAS	85	35	18
	MBKVAM3225A	RP1 225A MB kit, 35kA 3ph 3VA52, MFAS	85	35	18
	MBKVAM3250A	RP1 250A MB kit, 35kA 3ph 3VA52, MFAS	85	35	18
	MBKVAH3200A	RP1 200A MB kit, 65kA 3ph 3VA52, HFAS	100	65	25
	MBKVAH3250A	RP1 250A MB kit, 65kA 3ph 3VA52, HFAS	100	65	25
FD [Ⓞ] 3-ph 250A Max.	MBKFD3150A	Kit w/3-pole FXD6 150A breaker	65	35	22
	MBKFD3175A	Kit w/3-pole FXD6 175A breaker	65	35	22
	MBKFD3200A	Kit w/3-pole FXD6 200A breaker	65	35	22
	MBKFD3225A	Kit w/3-pole FXD6 225A breaker	65	35	22
	MBKFD3250A	Kit w/3-pole FXD6 250A breaker	65	35	22
3VA53 3-ph 400A Max. (coming soon)	MBKVAM1300A	RP1 300A MB kit, 35kA 1ph 3VA53, MJAS	85	35	18
	MBKVAM1400A	RP1 400A MB kit, 35kA 1ph 3VA53, MJAS	85	35	18
	MBKVAM3300A	RP1 300A MB kit, 35kA 3ph 3VA53, MJAS	85	35	18
	MBKVAM3400A	RP1 400A MB kit, 35kA 3ph 3VA53, MJAS	85	35	18
	MBKVAH3300A	RP1 300A MB kit, 65kA 3ph 3VA53, HJAS	100	65	25
	MBKVAH3400A	RP1 400A MB kit, 65kA 3ph 3VA53, HJAS	100	65	25
JD [Ⓞ] 1-ph 400A Max.	MBKJD1300A	Kit w/2-pole JXD6 300A breaker	65	35	—
	MBKJD1400A	Kit w/2-pole JXD6 400A breaker	65	35	—
	MBKJD12300A	Kit w/2-pole JXD2 300A breaker	65	—	—
	MBKJD12400A	Kit w/2-pole JXD2 400A breaker	65	—	—
JD [Ⓞ] 3-ph 400A Max.	MBKJD3300A	Kit w/3-pole JXD6 300A breaker	65	35	—
	MBKJD3400A	Kit w/3-pole JXD6 400A breaker	65	35	—
	MBKJD32300A	Kit w/3-pole JXD2 300A breaker	65	—	—
	MBKJD32400A	Kit w/3-pole JXD2 400A breaker	65	—	—

Branch Breakers Selection for P1

Selection Guide

1. Select breaker type.
2. Select required amperage.
3. Select number of poles.
4. Select branch breaker catalog numbers.
5. Select ground bar and filler plates. (See replacement parts & accessories on Page 10-14.)



300A Main installed.
These Revised P1 kits can now be used as top or bottom feed.

300A Main installed.
These Next Gen P1 kits can now be used as top or bottom feed.

[Ⓞ] These Main Breaker Kits are Make to Order only – expect extended lead-times.

Panelboards

Panelboard Replacement, Modification, and Additions

Selection

S1/S2 Panels—All the original P1 panel kits for 250 amp and below panels will work for 250 amp maximum S1/S2 panels

(will not work for S1/S2 400A and above).

Note: Revised P1 kits will not work with S1/S2 or SE Panels.

Original P1 Kits

Original P1 Main or Subfeed Strap Kits without Breakers and MLO kits

S1/S2 Panels—All the original P1 panel kits for 250 amp and below panels will work for 250 amp maximum S1/S2 panels (will not work for S1/S2 400A and above).

Note: Revised P1 kits will not work with S1/S2 or SE Panels.

Strap kits for Original P1 product only - Breaker kits not available				
Original P1 Catalog No.	Description of breaker type to order	Phase	Amps Max.	Available for Subfeed
MBKBL1	2-pole BL/BLH/HBL 15A-100A	1	100A	yes
MBKBL3	3-pole BL/BLH/HBL 15A-100A	3	100A	yes
MBKBC3	3-pole BQD 15A-100A	3	100A	yes
MBKNB1	2-pole NGB/LGB/HGB 15A-125A	1	125A	yes
MBKNB3	3-pole NGB/LGB/HGB 15A-125A	3	125A	yes
MBKED1	2-pole ED4/HED4 50A-125A	1	125A	yes
MBKED3	3-pole ED4/HED4 50A-125A	3	125A	yes
MBKQR1	2-pole QR(H)2/HQR2(H) 125A-225A	1	225A	yes
MBKQR3	3-pole QR(H)2/HQR2(H) 125A-225A	3	225A	yes
MBKFD1	2-pole F(X)D6/HF(X)D6 70A-250A	1	250A	yes
MBKFD3	3-pole F(X)D6/HF(X)D6 70A-250A	3	250A	yes
MBKJD1	2-pole JXD2/J(X)D6/HJ(X)D6 200A-400A	1	400A	NO
MBKJD3	3-pole JXD2/J(X)D6/HJ(X)D6 200A-400A	3	400A	NO

Strap kits for 400/600A S1/S2 and all SE panels - breakers not included				
Catalog No.	Description of breaker type to order	Phase	Amps Max.	Available for Subfeed
SMBKED1	2-pole ED2, ED4, ED6, HED4, HHED6	1	125A	yes
SMBKED3	3-pole ED2, ED4, ED6, HED4, HHED6	3	125A	yes
SMBKFD1	2-pole FXD6, FD6, HFXD6, HFD6	1	250A	yes
SMBKFD3	3-pole FXD6, FD6, HFXD6, HFD6	3	250A	yes
SMBKJD1	2-pole JD6, JXD6, HJD6, HJXD6	1	400A	yes
SMBKJD3	3-pole JD6, JXD6, HJD6, HJXD6	3	400A	yes

MLO kits for Original P1 product only

* MLO Kits available for SE Panels - AL 250A only

Note: 400/600A S1/S2 MLO kits no longer available

Original P1 Cat No.	Description	Phase	Amps Max.	Available for P1 Feed-thru
MLKA1*	(1) #6 AWG- 350 kcmil (CU or AL)	1	250A	yes
MLKA3*		3		yes
MLKC1	(1) #6 AWG- 350 kcmil (CU)	1	250A	yes
MLKC3		3		yes
4MLKA1	(2) 1/0 - 250 kcmil or (1) #2 AWG-600 kcmil	1	400A	yes
4MLKA3		3		yes
4MLKC1	(2) 1/0 - 4/0 or (1) 1/0 - 600 kcmil	1	400A	yes
4MLKC3		3		yes

Other applications:

For S5 and 12.75" deep SPP panels see page <?> for branch breaker mounting kits.

For F2 and 12.75" deep FPP panels see page <?> for branch fusible switch mounting kits.

For Series 5, Series 6, CDP6 and VB 6 panels as well as FC20, FCI, FCII, SB1, SB2 and SB3 distribution switchboards, see page 12-32 for branch device mounting kits.

Panelboards

Warehouse Stock/Unassembled

Selection

Branch Breakers Selection for P1

BL Family Circuit Breakers

Amp Ratings	1-Pole	2-Pole		3-Pole
	120V	240/120V	240V	240V
Type BL - 10,000A IR^①				
15	B115	B215	B215R	B315
20	B120	B220	B220R	B320
25	B125	B225	B225R	B325
30	B130	B230	B230R	B330
35	B135	B235	B235R	B335
40	B140	B240	B240R	B340
45	B145	B245	B245R	B345
50	B150	B250	B250R	B350
60	B160	B260	—	B360
70	B170	B270	—	B370
80	—	B280	—	B380
90	—	B290	—	B390
100	—	B2100	—	B3100
Type BLH - 22,000 IR^①				
15	B115H	B215H	—	B315H
20	B120H	B220H	—	B320H
25	B125H	B225H	—	B325H
30	B130H	B230H	—	B330H
35	B135H	B235H	—	B335H
40	B140H	B240H	—	B340H
45	B145H	B245H	—	B345H
50	B150H	B250H	—	B350H
60	B160H	B260H	—	B360H
70	B170H	B270H	—	B370H
80	—	B280H	—	B380H
90	—	B290H	—	B390H
100	—	B2100H	—	B3100H
Type HBL - 65,000A IR^①				
15	B115HH	B215HH	—	B315HH
20	B120HH	B220HH	—	B320HH
30	B130HH	B230HH	—	B330HH
40	B140HH	B240HH	—	B340HH
50	B150HH	B250HH	—	B350HH
60	—	B260HH	—	B360HH
70	—	B270HH	—	B370HH
80	—	B280HH	—	B380HH
90	—	B290HH	—	B390HH
100	—	B2100HH	—	B3100HH

BQD6 Family Circuit Breakers

Amp Ratings	1-Pole	2-Pole	3-Pole
	347V	600/347V	600/347V
Type BQD6 - 10,000A IR @ 600/347V			
15	BQD6115	BQD6215	BQD6315
20	BQD6120	BQD6220	BQD6320
25	BQD6125	BQD6225	BQD6325
30	BQD6130	BQD6230	BQD6330
35	BQD6135	BQD6235	BQD6335
40	BQD6140	BQD6240	BQD6340
45	BQD6145	BQD6245	BQD6345
50	BQD6150	BQD6250	BQD6350
60	BQD6160	BQD6260	BQD6360
70	BQD6170	BQD6270	BQD6370

① To add Shunt trip to BL breakers (factory assembled only), See PPC Breaker accessories section 5. One inch additional unit space required typically.

② To add Shunt trip or other accessories to BQD and NGB family breakers, See PPC Breaker accessories section 5. One inch additional unit space required typically for each.

BQD & GB Family Circuit Breakers

Amp Ratings	1-Pole	2-Pole	3-Pole
	277V	480Y/277V	480Y/277V
Type BQD^② - 14,000A IR @ 480/277V 65,000A IR @ 240V			
15	BQD115	BQD215	BQD315
20	BQD120	BQD220	BQD320
25	BQD125	BQD225	BQD325
30	BQD130	BQD230	BQD330
35	BQD135	BQD235	BQD335
40	BQD140	BQD240	BQD340
45	BQD145	BQD245	BQD345
50	BQD150	BQD250	BQD350
60	BQD160	BQD260	BQD360
70	BQD170	BQD270	BQD370
80	BQD180	BQD280	BQD380
90	BQD190	BQD290	BQD390
100	BQD1100	BQD2100	BQD3100
Type NGB - 14,000A IR @ 600/347V 100,000A IR @ 240V			
Amp Ratings	347V	600/347V	600/347V
15	NGB1B015B	NGB2B015B	NGB3B015B
20	NGB1B020B	NGB2B020B	NGB3B020B
25	NGB1B025B	NGB2B025B	NGB3B025B
30	NGB1B030B	NGB2B030B	NGB3B030B
35	NGB1B035B	NGB2B035B	NGB3B035B
40	NGB1B040B	NGB2B040B	NGB3B040B
45	NGB1B045B	NGB2B045B	NGB3B045B
50	NGB1B050B	NGB2B050B	NGB3B050B
60	NGB1B060B	NGB2B060B	NGB3B060B
70	NGB1B070B	NGB2B070B	NGB3B070B
80	NGB1B080B	NGB2B080B	NGB3B080B
90	NGB1B090B	NGB2B090B	NGB3B090B
100	NGB1B100B	NGB2B100B	NGB3B100B
110	NGB1B110B	NGB2B110B	NGB3B110B
125	NGB1B125B	NGB2B125B	NGB3B125B

Typical Cable Ranges by Breaker Type

UL Breaker Type	Amps	Connector Range for AL cable	Connector Range for CU cable
BL	15-20A	#12-#10 AWG	#14-#10 AWG
	25-35A	#8-#6 AWG	#8-#6 AWG
	10-50A	#8-#4 AWG	#8-#6 AWG
	55-70A	#8-#2 AWG	#8-#4 AWG
	80-100A	#2-#1/0 AWG	#4-#1/0 AWG
BQD	15-40A	#12-#6 AWG	#14-#6 AWG
	45-100A	#6-1/0 AWG	#8-#1 AWG
xGB	15-30A	#12-#6 AWG	#14-#6 AWG
	35-125A	#4-2/0 AWG	#6-1/0 AWG
3VA41	15-125A	#14 AWG - 3/0	#14 AWG - 2/0

BT Twin Family Circuit Breakers

The Space saver duplex breakers combine two independent 1/2" breaker poles in a common unit. This unit bolts into any location that would typically fit a 1-pole BL breaker and requires only 1" of panel space.

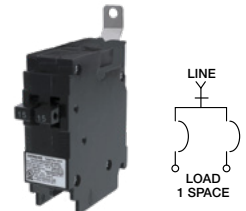

Replacement for 1-pole BL series (15A & 20A only)

Amp Ratings	Width	Circuits	BT (10k AIC)	BTH (22k AIC)	Details
Type BT and BTH					
15-15	1" pole	2	B1515	B1515H	Two 15A circuits
20-20	1" pole	2	B2020	B2020H	Two 20A circuits

Panelboards

Warehouse Stock/Unassembled

Selection

AFCI/GFCI

Electronic Circuit Breakers		1-Pole		2-Pole		Catalog Number		
Trip Type	Breaker Type	Max IR (kA) at 120V	Amp Ratings Available	Max IR (kA) at 120/240	Amp Ratings Available			
Combination AFCI	BAF2	10	15	—	—	BA115AFC		
		10	20	—	—	BA120AFC		
	BAFH2	22	15	—	—	BA115AFCH		
		22	20	—	—	BA120AFCH		
	HBAF2	65	15	—	—	BA115AFCHH		
		65	20	—	—	BA120AFCHH		
	BAF	—	—	10	15	B215AFC		
		—	—	10	20	B220AFC		
BAFH	—	—	22	15	B215AFCH			
	—	—	22	20	B220AFCH			
Dual Function AFCI/GFCI	BFGA2	10	15	—	—	B115DF		
		10	20	—	—	B120DF		
	BFGAH2	22	15	—	—	B115DFH		
		22	20	—	—	B120DFH		
	HBFGA2	65	15	—	—	B115DFHH		
		65	20	—	—	B120DFHH		
GFCI Personnel Protection (5mA)	BLF2	10	15	—	—	BF115A		
		10	20	—	—	BF120A		
		10	30	—	—	BF130A		
	BLF	—	—	10	15	B215GF		
		—	—	10	20	B220GF		
		—	—	10	30	B230GF		
		—	—	10	40	BF240A		
		—	—	10	50	BF250A		
		—	—	10	60	BF260A		
	BLHF2	22	15	—	—	BF115AH		
		22	20	—	—	BF120AH		
		22	30	—	—	BF130AH		
	BLHF	—	—	22	15	B215GFH		
		—	—	22	20	B220GFH		
		—	—	22	30	B230GFH		
		—	—	22	40	BF240AH		
		—	—	22	50	BF250AH		
		—	—	22	60	BF260AH		
	HBLF2	65	15	—	—	BF115AHH		
		65	20	—	—	BF120AHH		
		65	30	—	—	BF130AHH		
		GFCI Ground Fault Equipment Protection (30mA)	BLE	10	15	—	—	BE1153
				10	20	—	—	BE1203
				10	30	—	—	BE130
—	—			10	15	B215EG		
—	—			10	20	B220EG		
—	—			10	30	B230EG		
—	—			10	40	BE240		
—	—			10	50	BE250		
—	—			10	60	BE260		
BLEH	22			15	—	—	BE115H2	
	22	20	—	—	BE120H2			
	22	30	—	—	BE130H2			
	—	—	22	15	BE215H2			
	—	—	22	20	BE220H2			
	—	—	22	30	BE230H2			
	—	—	22	40	BE240H2			
	—	—	22	50	BE250H2			
	—	—	22	60	BE260H2			

① Built to order. Additional "circuit" is included for neutral (via pigtail) and is NOT connected to bus. 2-pole is one phase and one neutral pigtail. 3-pole is two phase connections and one neutral pigtail.

② Allow 8-10 weeks for delivery

③ UL Listed as SWD (Switching Duty) Rated, suitable for 120V AC fluorescent lighting

Panelboards

Warehouse Stock/Unassembled

Selection

3VA41 TMTU 125A max. - breakers w/AL lugs included

3VA41 1-Pole (1" wide)

		UL Type Code ==>	SEAB	MEAB	HEAB
		Panelboard MB codes ==>	V1	V2	V3
		120 VAC kAIC rating ==>	1-pole	1-pole	1-pole
		277 VAC kAIC rating ==>	65	85	150 ^①
		347 VAC kAIC rating ==>	25	35	65
		125 VDC kAIC rating ==>	14	18	25
			14 ^②	25 ^②	30 ^②
		IC family @ 277VAC ==>	25kA	35kA	65kA
amps	code	FTFM Trip included ==>	TM230	TM230	TM230
15	95	3VA41 1P breaker w/TM210 1 Pole 3VA41 with AL connectors included. For copper, use the following kits: 15A-40A use # 3VA9133-0JD10 45A-125A use # 3VA9133-0JD11 Note: No accessory pockets available	3VA4195-4ED11-0AA0	...-5ED...	...-6ED...
20	20		3VA4120-4ED11-0AA0	...-5ED...	...-6ED...
25	25		3VA4125-4ED11-0AA0	...-5ED...	...-6ED...
30	30		3VA4130-4ED11-0AA0	...-5ED...	...-6ED...
35	35		3VA4135-4ED11-0AA0	...-5ED...	...-6ED...
40	40		3VA4140-4ED11-0AA0	...-5ED...	...-6ED...
45	45		3VA4145-4ED11-0AA0	...-5ED...	...-6ED...
50	50		3VA4150-4ED11-0AA0	...-5ED...	...-6ED...
60	60		3VA4160-4ED11-0AA0	...-5ED...	...-6ED...
70	70		3VA4170-4ED11-0AA0	...-5ED...	...-6ED...
80	80		3VA4180-4ED11-0AA0	...-5ED...	...-6ED...
90	90		3VA4190-4ED11-0AA0	...-5ED...	...-6ED...
100	10		3VA4110-4ED11-0AA0	...-5ED...	...-6ED...
110	11		3VA4111-4ED11-0AA0	...-5ED...	...-6ED...
125	12		3VA4112-4ED11-0AA0	...-5ED...	...-6ED...

3VA41 1-Pole in 2-Pole Frame (2" wide)

		IC family @ 277VAC ==>	25kA	35kA	65kA
amps	code	FTFM Trip included ==>	TM230	TM230	TM230
15	95	3VA41 1P in 2-P Frame breaker w/TM230 1 Pole in 2-pole Frame 3VA41 with AL connectors included for CU order one 3VA9133-0JD11 connector kit Note: Only 3 Left side Accessory pockets available	3VA4195-4ED51-0AA0	...-5ED...	...-6ED...
20	20		3VA4120-4ED51-0AA0	...-5ED...	...-6ED...
25	25		3VA4125-4ED51-0AA0	...-5ED...	...-6ED...
30	30		3VA4130-4ED51-0AA0	...-5ED...	...-6ED...
35	35		3VA4135-4ED51-0AA0	...-5ED...	...-6ED...
40	40		3VA4140-4ED51-0AA0	...-5ED...	...-6ED...
45	45		3VA4145-4ED51-0AA0	...-5ED...	...-6ED...
50	50		3VA4150-4ED51-0AA0	...-5ED...	...-6ED...
60	60		3VA4160-4ED51-0AA0	...-5ED...	...-6ED...
70	70		3VA4170-4ED51-0AA0	...-5ED...	...-6ED...
80	80		3VA4180-4ED51-0AA0	...-5ED...	...-6ED...
90	90		3VA4190-4ED51-0AA0	...-5ED...	...-6ED...
100	10		3VA4110-4ED51-0AA0	...-5ED...	...-6ED...
110	11		3VA4111-4ED51-0AA0	...-5ED...	...-6ED...
125	12		3VA4112-4ED51-0AA0	...-5ED...	...-6ED...

① Although some breakers have a kAIC rating above 100 kAIC – many panels are limited to 100 kAIC or less.

② DC Voltage panels are limited by various factors. These DC ratings apply to the Breaker only.

Panelboards

Warehouse Stock/Unassembled

Selection

3VA41 TMTU 125A max. - breakers w/AL lugs included

3VA41 2-Pole & 3-Pole (2" & 3" wide)

		UL Type Code ==>	SEAB	MEAB	HEAB
		Panelboard MB codes ==>	V1	V2	V3
		240 VAC kAIC rating ==>	3-pole 2-pole	3-p 2-p	3-p 2-p
		480Y/277VAC kAIC rating ==>	65 65	85 85	150 ^① 150 ^①
		480 VAC kAIC rating ==>	25 25	35 35	65 65
		600Y/347VAC kAIC rating ==>	25 25	35 35	65 65
		600 VAC kAIC rating ==>	14 14	18 18	25 25
		250 VDC kAIC rating ==>	na na	na na	na na
		IC family @ 480VAC ==>	na 50 ^②	na 85 ^②	na 100 ^②
			25kA	35kA	65kA
amps	code	FTAM Trip included ==>	TM230	TM230	TM230
15	95	3VA41 2P breaker w/TM210 2 Pole 3VA41 with AL connectors included. For copper, use the following kits: 15A-40A use # 3VA9133-0JD10 45A-125A use # 3VA9133-0JD11 Note: Only 3 Left side Accessory pockets available	3VA4195-4ED21-0AA0	...-5ED...	...-6ED...
20	20		3VA4120-4ED21-0AA0	...-5ED...	...-6ED...
25	25		3VA4125-4ED21-0AA0	...-5ED...	...-6ED...
30	30		3VA4130-4ED21-0AA0	...-5ED...	...-6ED...
35	35		3VA4135-4ED21-0AA0	...-5ED...	...-6ED...
40	40		3VA4140-4ED21-0AA0	...-5ED...	...-6ED...
45	45		3VA4145-4ED21-0AA0	...-5ED...	...-6ED...
50	50		3VA4150-4ED21-0AA0	...-5ED...	...-6ED...
60	60		3VA4160-4ED21-0AA0	...-5ED...	...-6ED...
70	70		3VA4170-4ED21-0AA0	...-5ED...	...-6ED...
80	80		3VA4180-4ED21-0AA0	...-5ED...	...-6ED...
90	90		3VA4190-4ED21-0AA0	...-5ED...	...-6ED...
100	10		3VA4110-4ED21-0AA0	...-5ED...	...-6ED...
110	11		3VA4111-4ED21-0AA0	...-5ED...	...-6ED...
125	12	3VA4112-4ED21-0AA0	...-5ED...	...-6ED...	
amps	code	FTAM Trip included ==>	TM230	TM230	TM230
15	95	3VA41 3P breaker w/TM210 3 Pole 3VA41 with AL connectors included. For copper, use the following kits: 15A-40A use # 3VA9133-0JD10 45A-125A use # 3VA9133-0JD11 Note: 3 Left side and 3 right side Accessory pockets available	3VA4195-4ED31-0AA0	...-5ED...	...-6ED...
20	20		3VA4120-4ED31-0AA0	...-5ED...	...-6ED...
25	25		3VA4125-4ED31-0AA0	...-5ED...	...-6ED...
30	30		3VA4130-4ED31-0AA0	...-5ED...	...-6ED...
35	35		3VA4135-4ED31-0AA0	...-5ED...	...-6ED...
40	40		3VA4140-4ED31-0AA0	...-5ED...	...-6ED...
45	45		3VA4145-4ED31-0AA0	...-5ED...	...-6ED...
50	50		3VA4150-4ED31-0AA0	...-5ED...	...-6ED...
60	60		3VA4160-4ED31-0AA0	...-5ED...	...-6ED...
70	70		3VA4170-4ED31-0AA0	...-5ED...	...-6ED...
80	80		3VA4180-4ED31-0AA0	...-5ED...	...-6ED...
90	90		3VA4190-4ED31-0AA0	...-5ED...	...-6ED...
100	10		3VA4110-4ED31-0AA0	...-5ED...	...-6ED...
110	11		3VA4111-4ED31-0AA0	...-5ED...	...-6ED...
125	12	3VA4112-4ED31-0AA0	...-5ED...	...-6ED...	

① Although some breakers have a kAIC rating above 100 kAIC – many panels are limited to 100 kAIC or less.

② DC Voltage panels are limited by various factors. These DC ratings apply to the Breaker only.

Panelboards

Circuit Breaker / Lighting and Distribution

General

Revised Type P1

600Y/ 347 Vac Maximum
400A max. Main Breakers
250A max. Branch Breakers
Short Circuit Rating —
200,000 A. @ 240 Vac / 100,000 A. @
600Y/347 Vac. IR Maximum

Branch Breaker Symmetrical Interrupting Capacity

Based on CSA's Test Procedure

Feed thru and subfeed lugs may result in lower interrupting ratings if not protected by a main device. Consult sales office.

Panelboards

Certified by CSA under file #165172 and listed by Underwriters' Laboratories, Inc., under "Panelboards" File #E2269 for interiors and #E4016 for boxes and fronts.

Service

- 1-phase 2-wire - 120 Vac, 240 Vac,
- 1-phase 3-wire - 120/240 Vac,
- 3-phase 3-wire - 480Y/277 (when derived from 3-phase 4-wire system), 240 Vac, 120 Vac
- 3-phase 4-wire - 208Y/120 Vac, 480Y/277 Vac, 600Y/347 Vac, 380/220 Vac.

Panelboard Fronts and Doors

Standard panelboards are furnished with trim featuring concealed fasteners and hinges with a flush door lock. All are factory-assembled for ease of installation. Fronts are fabricated from code gauge steel and finished ANSI-61. See page 10-29 for optional fronts.

Main Breakers

BL, BLH, HBL, NGB, BQD, BQD6, ED4, ED6, HED4, QR2, QRH2, HQR2, HQR2H, FXD6, FD6, HFD6, HFDX6, JXD6, JD6, HJXD6, HJD6, 3VA41/52/61/62/53/63. (All main breakers except 400 amp frame are mounted horizontal.)

Note: Revised P1 interiors with BL, BQD, GB or 3VA41 type mains can be back-fed in unit space. See special notes for unit space reduction.

Main Breaker Panel Connectors^⑦

Ampere Rating	Connectors Suitable for Cu or Al
100	(1) —#14 1/0 AWG
125	(1) —#4 1/0 AWG
225	(1) —#4 AWG-300 kcmil
250	(1) —#4/0 AWG-350 kcmil Al (1) —#6/0 AWG-350 kcmil Cu
400 ^①	(2) —#3/0 AWG-250 kcmil Al or (1) —#3/0 AWG-500 kcmil Al

Connector ranges indicated do not apply to all main breaker types. Refer to molded case circuit breaker standard pressure wire connector chart (Section 5) for the connector range of a specific frame.

Main Lug Connectors^②

125	(1) —#6 AWG-350 kcmil
250	(1) —#6 AWG-350 kcmil
400 std.	AL (2) 1/0-250 kcmil or (1) #2 AWG-600 kcmil
400 opt.	CU (2) 1/0-4/0 or (1) 1/0-600 kcmil
400 opt.	AL (1) AL 1/0-750 kcmil (2) AL/CU 250 kcmil max. [max. (1) 600 kcmil CU wire]

Boxes

- 20" wide, 5.75" deep
- End walls are blank as standard.
- End walls with knockouts are available for 5.75" deep enclosures, if requested at time of order, and are available as a field installable kit.

Main Breaker Gutter Dimensions - Inches

Main Breaker	Side Gutter		Neutral Location
	20" w/box	24" w/box	20" w/box
BL, BLH, HBL, BQD, BQD6	8.500	10.5	11.5
NGB	8.000	10	11.5
ED4, ED6, HED4	6.125	8.125	11.5
QR2, QRH2, HQR2, HQR2H	6.500	8.5	11.5
FD6, FXD6, HFD6, HFDX6	5.250	7.25	11.5
JD6 ^② , JXD6 ^②	15.000	15	26.75

Main Lug End Gutter

Dimensions - Inches

Amp Rating	End Gutter	Neutral Location
125	10.500	11.5
250	10.500	11.5
400 ^③	25.500	26.75

Weight — Approximate

Total panelboard weight when filled with a normal quantity of breakers and accessories is:

- About 3 lbs. per inch of box height

Gauge Steel Boxes (Type 1)

Width	Height	Gauge Steel
20"	All	#16

Fronts — Surface, Flush (Type 1)

20"	All	#14
-----	-----	-----

Series Connected Short Circuit Ratings

The term "Series Connected Short Circuit Rating" refers to the application of series connected circuit breakers in a combination that allows some breakers to have lower individual interrupting ratings than the available fault current. This is permitted as long as the series combination has been CSA/UL tested and certified.

(see section 5 - Circuit Breakers - of this catalogue).

These series ratings must be specified at time of placing the order.

① P1 400 amp main breaker panels have wire bending space available for 600 kcmil.
 ② 400A main breaker is vertical mounted.
 ③ Feed-thru lug wire bending space is 15.000" (381mm) and neutral wire bending space is 15.880" (413mm) on 400A panel.
 ④ P1 panel limited to (1) subfeed 250 amperes max.
 ⑤ See Branch Breaker Side Gutter Chart for Nex Gen P1 Backfed Options.

⑥ See complete list of MLO connectors on page <?>.
 ⑦ Reference info: Neutral Lugs are rated for 75°C cable. When running a circuit to a load, the same type of wire should be used on the phase (breaker) and neutral connections in the panel.
 a) Cables should be sized per NEC Table 310.16 (formerly Table 310.15(B)(16)) and the 75°C column.
 b) Customer can choose to use 90C cable if sized as if it is 75°C.

c) Some 100% rated circuit breakers require the use of 90°C cable sized per the 75°C column. Refer to the Markings on the breaker and use the appropriate cable.
 d) Some Circuit breakers 100A or less are marked as being suitable for 60°C, 75°C or 60/75°C cable. Refer to the Markings on the breaker and use the appropriate cable.

For inches / millimeters conversion, see Application Data section.

Panelboards

Circuit Breaker / Lighting and Distribution

Selection

Table P1-3 – Main Breaker Panel Size Selector – Revised P1

RP1 Est. size/weights for AL MLO panels. - Add Main Breaker weights as needed. - Add 20% for CU Bus.		Max # of 1" Poles		Max # of Poles w/BT ²		Dimensions in inches (mm)			MLO ¹ Estimated Weight in Lbs. (kg) with Breakers
Type of RP1 interior ==>		BL/BQD or xGB/3VA41 ³		BL/BQD only		Unit Space		Box Height B"(mm)	
Main Breaker Amp Rating / Type	Main Lug Amp Rating	FT #	NFT #	FT w/BT	NFT w/BT	FT A"	NFT A"		
250A max. Main Bus rating 100A max BL or BQD series 125A max xGB or 3VA41 Series (coming soon) or 225A max QR Series (coming soon) 250A max FD or 3VA52/62 Series (coming soon)	125A or 250A (all bus is 250A max.)	–	18	–	18 + 10	–	9	26 (661)	95 (43)
		18	30	18 + 10	30 + 20	9	15	32 (813)	110 (50)
		30	42	30 + 20	42 + 30	15	21	38 (965)	125 (57)
		42	54	42 + 30	54 + 30	21	27	44 (1118)	140 (64)
		54	66	54 + 30	66 + 30	27	33	50 (1270)	155 (71)
400A max. Main Bus rating 400A max JD Series or 400A max 3VA53/63 Series	400A (all bus is 400A max.)	–	30	–	30 + 20	–	15	56 (1423)	172 (78)
		30	42	30 + 20	42 + 30	15	21	62 (1575)	190 (86)
		42	54	42 + 30	54 + 30	21	27	68 (1728)	208 (95)
		54	66	54 + 30	66 + 30	27	33	74 (1880)	226 (104)

¹ Estimated weights are for Aluminum bus MLO panels and vary by MB and installed Branches
² BT - twin style breakers are available in 15A and 20A only and provide two 1-pole circuits in 1" of unit space.
 The maximum Qty. of BT twins allowed in a panel is restricted to the max. number of neutral positions and/or physical space available, whichever is lower. Values shown are recommended maximums.
³ BT twins can only be used in BL/BQD RP1 panels. The NGB series of interiors do not accept BL/BQD or BT style of breakers.

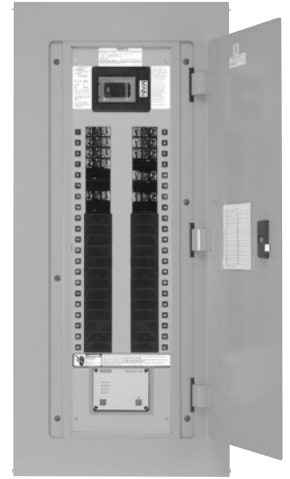

Table P1-4 – Main Breaker Selection

P1 Main Circuit Breakers & Subfeed					2-Pole and 3-Pole					Amp Ratings Available	Available for Sub-feed Horizontal mount only	
					Max IR (kA) at ⁴							
Amp Rating	Trip Type	Breaker Family	Main Breaker Code	Breaker Type	240V	480V /277V	480V	600V /347V	600V			
70	Thermal Magnetic	BOD6	B6	BOD6	65	–	–	10	–	15-70	Single	
100		BL	BL	BL	BL	10	–	–	–	–	15-100	Single
			BH	BLH	BLH	22	–	–	–	–	15-100	Single
			HB	HBL	HBL	65	–	–	–	–	15-100	Single
125	Thermal Magnetic	Sentron GB	NB	NGB	100	25	–	14	–	15-125	Single	
			G2	HGB	100	35	–	14	–	15-125	Single	
			G3	LGB	100	65	–	14	–	15-125	Single	
		3VA41 (coming soon)	ED	E4	ED4	65	–	18	–	–	15-125	Single
				E6	ED6 ⁵	65	–	25	–	18	20-125	Single
				H4	HED4	100	–	42	–	–	15-125	Single
				V1	SEAB	65	–	–	–	14	15-125	Single
V2	MEAB	85	–	35	–	18	15-125	Single				
V3	HEAB	100	–	65	–	25	15-125	Single				
225	Thermal Magnetic	Sentron QR	QR	QR2	10	–	–	–	–	100-225	Single	
			Q4	QRH2	25	–	–	–	–	100-225	Single	
			Q5	HQR2	65	–	–	–	–	100-225	Single	
			Q6	HQR2H	100	–	–	–	–	100-225	Single	
250	Thermal Magnetic	Sentron FD	FX, FD	FXD6-A, FD6-A	65	–	35	–	22	70-250	Single	
			HF	HFD6	100	–	65	–	25	70-250	Single	
			H2	HFXD6	100	–	65	–	–	70-250	Single	
250 [150]	Thermal Magnetic	3VA52 (W/TM230 trip) (coming soon)	VA	MFAS	85	–	35	–	18	100-250	Single	
			VB	HFAS	100	–	65	–	25	100-250	Single	
			VC	CFAS	200	–	100	–	35	100-250	Single	
	Electronic (Solid state)	3VA62 [3VA61] (ETU350 LSI standard) (coming soon)	WA [W2]	MFAE [MDAE]	100	–	35	–	18	100-250 [40-150]	Single	
			WB [W3]	HFAE [HDAE]	100	–	65	–	22	100-250 [40-150]	Single	
400	Thermal Magnetic	Sentron JD	JX, J6	JXD6-A, JD6-A	65	–	35	–	25	200-400	n/a	
			H5, H6	HJXD6-A, HJD6-A	100	–	65	–	35	200-400	n/a	
			JD	JXD2	65	–	–	–	–	300-400	n/a	
			VE	MJAS	85	–	35	–	18	200-400	n/a	
400	Thermal Magnetic	3VA53 (W/TM230 trip) (coming soon)	VF	HJAS	100	–	65	–	25	200-400	n/a	
			VG	CJAS	200	–	100	–	35	300-400	n/a	
			WE	MJAE	100	–	35	–	18	100-400	n/a	
	Electronic (Solid state)	3VA63 (ETU350 LSI standard) (coming soon)	WF	HJAE	100	–	65	–	22	100-400	n/a	
			WG	CJAE	200	–	100	–	35	100-400	n/a	
WH	LJAE	200	–	150	–	50	100-400	n/a				

Panelboards

Circuit Breaker / Lighting and Distribution

Selection

Table P1-5 - Line/Load Cable Connector Size Chart

Max Amp Rating	Main Lug	Amp Series	Connections suitable for Copper Cable	Connections suitable for Aluminum Cable
125	Aluminum body	125A max	(1) #6 AWG - 350 kcmil	(1) #6 AWG - 350 kcmil
	Copper body	125A max	(1) #6 AWG - 350 kcmil	not suitable
250	Aluminum body	250A max	(1) #6 AWG - 350 kcmil	(1) #6 AWG - 350 kcmil
	Copper body	250A max	(1) #6 AWG - 350 kcmil	not suitable
400 std.	Aluminum body	400A max	(2) 1/0 - 4/0 or (1) #2 AWG - 600kcmil	(2) 1/0 - 250 kcmil or (1) #2 AWG-600kcmil
	Copper body	400A max	(2) 1/0 - 4/0 or (1) 1/0 - 600kcmil	not suitable for AL
400 alt.	Aluminum body	400A max	(2) 1/0 - 250 kcmil or (1) 1/0 - 600kcmil	(2) 1/0 - 250 kcmil or (1) 1/0 - 750kcmil
Max Amp	Main Breaker Types	Series	Connections for Copper	Connections for Aluminum
100	BL, BLH, HBL	15-35A 40-50A 55-100A	#14-#6 AWG #8-#6 AWG #8 AWG - 2/0	#14-#6 AWG #8-#4 AWG #8 AWG - 2/0
	BQD	15-40A 45-100A	#14-#6 AWG #8-#1 AWG	#12-#6 AWG #6 AWG -1/0
125	NGB, HGB, LGB	15-30A 35-125A	#14-#6 AWG #8 AWG-1/0	#12-#6 AWG #8-2/0 AWG
	ED4 ED6, HED4	15-25A 30-100A 110-125A (1-P) 30-60A (1-P) 70-100A	#14-#10 AWG #10 AWG -1/0 #3 AWG-3/0 #10-#4 AWG #6 AWG- 1/0	#12-10 AWG #10 AWG -1/0 #1 AWG-2/0 #10-#4 AWG #6 AWG- 1/0
	3VA41 (coming soon)	15-40A 45-125A	#14-#10 AWG #14AWG - 3/0	#14-#10 AWG #14AWG - 2/0
225	QR2, QRH2, HQR2, HQR2H	100-225A	#3 AWG-300 Kcmil	#3 AWG-300 Kcmil
250 [150]	FXD6, FD6, HFD6, HFXD6	70-250A	#6 AWG-350 Kcmil	#4 AWG-350 Kcmil
	3VA52	100-250A	#6 AWG-350 Kcmil	#6 AWG-350 Kcmil
	3VA62 [3VA61] (coming soon)	40-250A [16-150A]	#6 AWG-350 Kcmil	#6 AWG-350 Kcmil
400	JD6, JXD6, HJD6, HJXD6	200-400A	(1)or(2) 3/0-500 Kcmil [dual port lug]	(1)or(2) 4/0-500 Kcmil [dual port lug]
	3VA53 (coming soon) 3VA63 (coming soon)	200-400A 100-400A	(1)or(2) 2/0-600 kcmil [dual port lug]	(1)or(2) 2/0-600 kcmil [dual port lug]

Note: Main breakers use breaker connectors. For sizes, see breaker connector chart. 400A MLO Panels have wire bend space for 600kcmil CU & AL wire when using standard lugs. With optional 750kcmil AL/CU connectors, wire bend space is available for up to 750kcmil AL wire, but is still limited to 600kcmil CU wire.

Table P1-6 – Branch Circuit Breakers

Revised P1 Branch Circuit Breakers ^①				1-Pole					2-Pole and 3-Pole								
Amp Rating	Trip Type	Breaker Family	Breaker Type	Max IR (kA) at				Amp Ratings Available	Max IR (kA) at								Amp Ratings Available
				120V	277V	347V	125V DC ^③		120/240V	240V	480Y/277V	480V	600Y/347V	600V	125/250V DC ^③	250V DC ^③	
100	Thermal Magnetic	BL	BL, BT ^②	10	—	—	—	15-70 ^②	10	10	—	—	—	—	—	—	15-100 ^④
			BLH, BTH ^②	22	—	—	—	15-70 ^②	22	22	—	—	—	—	—	—	15-100 ^④
			HBL	65	—	—	—	15-50	65	65	—	—	—	—	—	—	15-100
	Special ^② Application	BLG	10	—	—	—	15-20	10	—	—	—	—	—	—	—	30	
		BL	10	—	—	—	15-30	10	—	—	—	—	—	—	—	15-30	
Thermal Magnetic	BQD	BQD ^⑤	65	14	—	14	15-100	—	65	14	—	—	—	14	—	15-100	
		BQD6 ^⑥	65	—	—	14	15-70	—	65	—	—	10	—	14	—	15-70	
XX	Electronic and misc.	BL	AFCI/GFCI & Dual Function	X	—	—	—	see special table page <?>	x	—	—	—	—	—	—	—	see special table page <?>
125	Thermal Magnetic	GB	NGB	100	25	14	14	15-125	—	100	25	—	14	—	14	—	15-125
			HGB	100	35	14	14	15-125	—	100	35	—	14	—	14	—	15-125
			LGB	100	65	14	14	15-125	—	100	65	—	14	—	14	—	15-125
		3VA41 ^③ (coming soon)	SEAB	65	25	14	14	—	65	65	25	25	14	—	50	50	15-125
			MEAB	85	35	18	25	—	85	85	35	35	18	—	85	85	15-125
HEAB	150	65	25	30	—	150	150	65	65	25	—	100	100	15-125			

① Unit space is 1 inch per pole, except for Special Application with accessory included.
 - No branch kits available, unit space for all branch positions is twin mount.
 - Branch space is either for BL/BQD only (or) for xGB/3VA41 only.
 ② BLG: Two-pole breaker is one phase and neutral. Three pole is two phases and neutral
 - See section 5-31 for additional info. Some are Built to order. Allow 2-3 weeks delivery.
 ③ DC Voltage Systems are not approved for use in P1 panels. Refer to P2/P3 panels if DC Voltage Systems are needed.

④ 110A-125A BL/BLH (2-pole only) available as Main or Subfeed only in Revised P1 panels.
 ⑤ Approved for CSA and UL Listed.
 ⑥ Approved for CSA but not UL Listed.
 ⑦ BT and BTH are only available in 15A and 20A with two 1-pole circuits in one inch of unit space.

Panelboards

Circuit Breaker / Lighting and Distribution

Dimensions

Table P1-13 – Main Breaker Gutter Dimensions Inches (mm)

Main Breaker	Gutter Space inches (mm)		Neutral Location to Endwall
	20" wide box	24" wide box	20" wide box
BL, BLH, HBL ^②	8.500 (215) ^③	10.500 (267) ^③	10.000 (254)
BQD ^②	7.750 (196) ^③	9.750 (248) ^③	10.000 (254)
NGB, HGB, LGB ^②	7.500 (190) ^③	9.500 (241) ^③	10.000 (254)
ED4, ED6, HED4	6.125 (156)	8.125 (206)	10.000 (254)
QR2, QRH2, HQR2, HQR2H	6.500 (165)	8.500 (216)	10.000 (254)
3VA41 (coming soon)	7.250 (184)	9.250 (235)	10.000 (254)
3VA52 (coming soon)	6.750 (171)	8.750 (222)	10.000 (254)
3VA61/62 (coming soon)	6.250 (159)	8.250 (210)	10.000 (254)
3VA53/63 ^③ (coming soon)	7.500 (190) / 12.250 (305)	14.750 (375) / 12.250 (305)	24.500 (622)
FD6, FXD6, HFD6, HFXD6	5.250 (133)	7.250 (184)	10.500 (267)
JD6, JXD6 ^①	15.000 (381)	15.000 (381)	26.500 (674)

^① 3VA53/63 or JD frame mounted vertically.

② For Revised P1 with Back-fed Main option, use Side Gutter Wiring Spec Table P1-15.

^③ These dimensions are for Revised P1 only. See Original P1 cut sheets for valid dimensions if needed (P1 production prior to June 2015).



Feed-Thru (FT)

Table P1-14 – Main Lug End Gutter Dimensions Inches (mm)

Amp Rating	End Gutter		Neutral Location - to Endwall	
	20" wide box	24" wide box	20" wide box	24" wide box
125	9.500 (242)	9.500 (242)	10.500 (267)	10.500 (267)
250	9.500 (242)	9.500 (242)	10.500 (267)	10.500 (267)
400	25.500 (648)	25.500 (648)	26.750 (680)	26.750 (680)

NOTE: Feed-thru lug and neutral wire bending space is 15.000" and 16.250" respectively on 400A panel.

Table P1-15 – Side Gutter Wiring Space Inches (mm) (Fig P1-1)

Reference Letter	Panel Width 20"	Panel Width 24" Optional
A ^②	6.375 (167)	8.375 (213)
B ^②	5.500 (140)	7.500 (191)
C ^②	5.000 (127)	7.000 (178)
D	6.125 (156)	8.125 (206)
E	6.500 (165)	8.500 (216)
F	5.250 (133)	7.250 (184)
G	6.750 (171)	8.750 (222)
H	6.250 (159)	8.250 (210)

^① Subfeed mounting limit 1 per panel.

② For all Revised P1 panels using BL/BQD or xGB breakers as mains in back-fed position, use this chart for wiring space.

NOTE: See page <?> for Main Breaker trip handle height reference chart.

Table P1-1

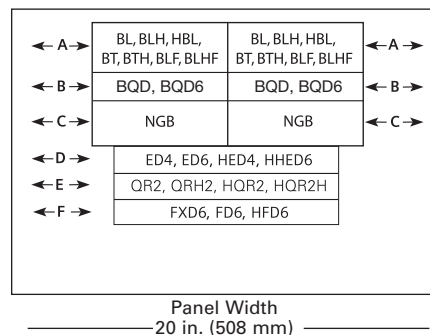

Non-Feed-Thru (NFT)



Panelboards

Type P1 Panelboard Modifications and Additions

Selection

Panel Options

Enclosures

- Extra gutter to sides or ends of the can
- 24" wide boxes
- Hinged trims
- Door-in-door trims
- Screw to the box trims
- Piano hinge trims
- Painted boxes
- Custom colors
- Stainless steel trims and boxes
- Type 1 enclosures (Std 16 Gage)
- Type 3R/12 enclosures 16 Gauge Can w/ 14 Gauge front)
- Type 4 enclosures (14 Gauge only)
- Type 4X enclosures (14 Gauge only - 304SS Std, 316SS Optional)
- Panel skirts
- Gaskets between trim and box

Surge Protection Devices

- TPS3 02
 - Bus connected
 - Internally mounted (30A breaker required to feed SPD)
 - Externally mounted in a 15" high aux. enclosure (30A breaker required to feed SPD)
- TPS3 09
 - Internally mounted (20A breaker required to feed SPD)
 - Externally mounted (20A breaker required to feed SPD)
- TPS3 12
 - Externally mounted (40A breaker required to feed SPD)

Panel Modifications

Enclosures

- Main Bus
- Standard main bus is tin-plated aluminum. For copper main bus, add from the table for each panel. Includes copper neutral cross bar. For copper neutral branch lugs, see miscellaneous.
- Compression lug for MLO[Ⓞ]
- Branch and main breaker accessories
 - Handle blocks
 - Handle locks
- Feed-thru lugs[Ⓞ]
Cannot be used in conjunction with SPD/TVSS or subfeed breakers. Do not add height to the panel.

- Copper lugs, mechanical line and branch neutral[Ⓞ]
- Bus mounted SPD/TVSS and unit space mounted BSPD[Ⓞ]
- Grounding of Panelboards
- Ground Bars except for brazed to box are shipped with the panel interior factory mounted.
 - Non-Insulated Equipment Ground Bar – Standard
 - Copper Non-Insulated Ground Bar
 - AL Insulated Equipment Ground Bar
 - CU Insulated Equipment Ground Bar
- Shunt Trip on Main or Branch
BL[Ⓞ], BLH[Ⓞ], HBL[Ⓞ], BQD[Ⓞ], BQD6, NGB[Ⓞ] as branch use 1" unit space for shunt trip.

QR2, QRH2, HQR2, HQR2H, ED2, ED4, ED6, HED4, FD6, FXD6, HFD6
HFXD6, JXD6, JD6, HJD6, HJXD6

Feed-thru Lugs Amp Rating	Type	Connector CU/AL Range
250	AL/CU Mechanical	(1)-#6 AWG- 350 kcmil
	CU Mechanical	(1)-#6 AWG- 350 kcmil
	AL/CU Compression	(1)-#6 AWG- 350 kcmil
400	AL/CU AWG Mechanical	(2)-#1/0 - 250 kcmil or (1)-#2 AWG- 600 kcmil
	CU	(1)-1/0-600 kcmil (2)-1/0-4/0
	AL/CU Compression	(1) 400-600 kcmil AL (1) 400-500 kcmil CU

- 200% neutral[Ⓞ]

NOTE: Specify copper or aluminum cable.

[Ⓞ] Do not increase panel or enclosure size.

[Ⓜ] Accessories on 1" pole breakers (BL, BQD, xGB, ED) will take 1" unit space.

[Ⓞ] External to the panel, supplied in a separate enclosure.

Panelboards

Type P1 Panelboard Modifications and Additions

Reference

Compression Lugs

Table P1-19 – Lugs

Style	Amp Rating	Breaker Type	Compression Connectors	Box Height Addition
MLO	125	N/A	(1) #6 AWG - 350 kcmil	None
	250			
	400	N/A	(1) 400 - 600 kcmil AL (1) 400 - 500 kcmil CU	None
Main Breaker	125	ED4, ED6, HED4	(1) #14 AWG - 2/0	Box must go to 24" wide
	225	QR2, QRH2, HQR2, HQR2H	(1) #6 AWG - 350 kcmil CU or AL	Box must go to 24" wide
	250	FXD6, HFD6	(1) #6 AWG - 350 kcmil CU or AL	Box must go to 24" wide

NOTE: Standard compression lugs used for P1 panels are range taking lugs and require a particular crimping tool (tool is Hubbell/Anderson Versa Crimp VC6 -for 250A) to accommodate the range. Consult factory for information. 200% neutral not available with compression lugs. xGB breakers cannot accommodate compression lugs. (For 400A tool use Hubbell/Anderson Versa Crimp VC6FT/VC7FT - see instruction sheet for details.)

Enclosure Modifications

Type-4–Water Tight, Dust Tight, Steel Enclosure

(Actual Type-4 enclosure is larger than standard Type 1 enclosure. See chart below for reference to approximate actual size.)

Table P1-20

Standard Box Height (in inches)	Actual NEMA 4 Enclosure Size		
	H	W	D
32	32	20	8
38	42	30	8
44	48	36	8
56	60	36	10

NOTE: Larger Type 4 enclosures are not available.

Remote Switch Modifications

Table P1-22 – Control Power Transformer

Size	VA Power
0, 1	50
2	75
3	150
4	250

Table P1-24 – Remote Control (with auxiliary contacts)

Description
Auxiliary Contacts (mounted, not wired)
2-Wire Control

Type-4X Water Tight, Dust Tight and Corrosion Resistant

(consult plant to verify actual enclosure size)

Table P1-21

Catalogue Number	Enclosure – Stainless Steel Size (inches) (304SS is standard)		
	H	W	D
B4X26	26	20	5.75
B4X32	32	20	5.75
B4X38	38	20	5.75
B4X44	44	20	5.75
B4X50	50	20	5.75
B4X56	56	20	5.75
B4X62	62	20	5.75
B4X68	68	20	5.75
B4X74	74	20	5.75

NOTE: 316SS is available as an option – must be specified.

Gauge Steel of Boxes/Fronts, Surface and Flush

Dimensions in Inches (mm)		Gauge Steel		
H	W	Box	Front/Door	Type
26-74 (660-1880)	20 (508)	16 ^①	14 ^③	Type 1
26-74 (660-1880)	20 (508)	16 ^②	16/14 ^②	Type 3R/12
32-60 (813-1524)	20-36 (508-914)	14 ^③	14 ^③	Type 4
26-74 (660-1879)	20 (508)	14 ^④	14 ^④	Type 4X

① 16 Gauge is Standard (14 Gauge & 12 Gauge are optional)

② 15 Gauge Steel Can with 14 Gauge Door or Similar Approved Construction

③ No Optional Gauge available

④ 304SS 14 Gauge Std., 316SS 14 Gauge optional

Panelboards

TPS Surge Protection products for RP1-P2-P3 Panelboards

Selection

Siemens TPS Surge Protection

The new TPS4 01/L1 series has been added to our internal mount SPD family for Lighting panels. This series provides many additional benefits and features not available with TPS3 01/L1 series or the TPS3 02/L2 series (for RP1 only). TPS4 series uses different MOV technology than the Mersen TPMOV used in TPS3 series. The TPS4 product leverages a MOV 'pill stack' design that also includes thermal protection, that is proven in the telecomm and other industries for many years. Look for comparisons for these products online for more information.

Wired versions of the TPS4 01/L1 series allow for connection to bus by cabling to a branch breaker in the panel when specs require a disconnect for the installation.

This TPS4 01/L1 series is designed for form/fit/function to replace both the TPS3 01/02 or TPS3 02/L2 series in most applications, but some differences must be considered - see important notes below:

- 1) TPS4 01/L1 series is designed to directly bolt to the bus of Revised P1 product (RP1). There are no adapters needed which makes installation easier. For field replacement of TPS3 02/L2, the entire TPS3 kit must be removed and the new TPS4 kit can be installed.
- 2) The TPS4 01/L1 series is NOT compatible with Original P1 series so TPS3 01/L1 must be used for Original P1 as either initial installation or as replacement.
- 3) TPS4 01/L1 can be used to replace TPS3 01/L1 in most RP1/P2/P3 applications where specs will allow. P2/P3 will need an additional kit ordered to adapt to the interior properly. Order Kit # TPS4P2P3K - SPD KIT P2 P3 TPS4.

Customer Interaction Centre (CIC) should be contacted if there are any questions regarding field replacement of SPD products.

TPS4 01 and TPS4 L1 Key Features

(see section 9 for a complete list)

- UL 1449-5 Type 2 SPD CSA 22.2 No. 269 and UL 1283 Listed
 - Optional UL 1449 5th Edition Listed Type 1
- Type 1 / Type 2 SPD
- 100 - 500 kA Per Phase Surge Current
- UL 96A Lightning Protection Master Labeling compliant (@ 20 kA)
- Modes of Protection: L-N, L-G, N-G, and L-L
- Dimensions: 9.25" x 4.5" x 4.29" (235 mm x 114.3 mm x 109 mm)
- Weight: 4.55 lb. (2.06 kg)



TPS4 01

Ordering Information

Catalog # TPS4 01

Voltage Code	Surge Current (kA)	Options	
A = 240/120 V, 1Ø, 3W ^①	10 = 100 kA per phase	X = Surge counter (Standard)	2 = Type 2 SPD (Default) Includes UL 1283 EMI/RFI Filters 0 = Type 1 SPD (Consult Factory Prior to Ordering)
B = 240/120 V, 3Ø, 4W	15 = 150 kA per phase	0 = Std config (default)	
C = 208/120 V, 3Ø, 4W	20 = 200 kA per phase	W = Terminal lug	
W = 220/127 V, 3Ø, 4W	25 = 250 kA per phase	0 = Std config (default)	
D = 240 V, 3Ø, 3W	30 = 300 kA per phase	B = Busway application	
E = 480/277 V, 3Ø, 4W	40 = 400 kA per phase	M = MCC application	
F = 480 V, 3Ø, 3W	50 = 500 kA per phase		
G = 600 V, 3Ø, 3W ^②			
K = 380/220 V, 3Ø, 4W			
L = 600/347 V, 3Ø, 4W			
S = 400/230 V, 3Ø, 4W			
T = 415/240 V, 3Ø, 4W			

Example: **TPS4C0120X000** = SPD for a 208/120V panelboard with a surge current capacity of 200 kA per phase and a surge counter option.
When an option is not selected, include a zero (0) in the field.

- ① Can also be used on 208Y/120V, 1Ø, 3W System
- ② Not available in 300, 400 or 500 kA versions

Please note: The TPS4 01 series is not suitable for use in the Original P1 Lighting Panels - Only Revised P1 Lighting Panels.



TPS4 L1

Common TPS4 01 SPD Catalog Reference

(see SPD section 9 for complete list including L1)

Catalog #	Description reference
TPS4A0110X002	SPD2 100kA 240/120V 1P3W SC
TPS4A0115X002	SPD2 150kA 240/120V 1P3W SC
TPS4B0110X002	SPD2 100kA 240/120V 3P4W SC
TPS4B0115X002	SPD2 150kA 240/120V 3P4W SC
TPS4C0110X002	SPD2 100kA 208/120V 3P4W SC
TPS4C0115X002	SPD2 150kA 208/120V 3P4W SC
TPS4C0120X002	SPD2 200kA 208/120V 3P4W SC
TPS4C0125X002	SPD2 250kA 208/120V 3P4W SC
TPS4E0110X002	SPD2 100kA 480/277V 3P4W SC
TPS4E0115X002	SPD2 150kA 480/277V 3P4W SC
TPS4E0120X002	SPD2 200kA 480/277V 3P4W SC
TPS4F0110X002	SPD2 100kA 480V 3P3W SC
TPS4F0115X002	SPD2 150kA 480V 3P3W SC
Kit below is needed for P2/P3 installation only	
TPS4P2P3K	SPD KIT P2 P3 TPS4 ADDER

Note: P2/P3 SPD's are factory installed only. For field replacement in P2/P2 panels, these same part numbers can be used to replace TPS3 01/L1 but an additional kit is needed only if replacing TPS3 with TPS4. Order kit # TPS4P2P3K - SPD KIT P2 P3 TPS4 ADDER

Panelboards

Type P1 Enclosure Details

Dimensions

P1 Endwall to Main or Subfeed Trip Handle Distance

Interior =>	P1 250A			P1 400A							
Mains =>	includes BL/BQD and 3VA Mains (coming soon)			includes 3VA53/63 mains. (coming soon) JD dimensions +/- 1" from these values							
Feed =>	Top & Bottom Feed			Top Feed				Bottom Feed ^①			
Box size	A	B/D ^②	C ^②	A	B	C ^②	D ^②	A	B	C ^②	D ^②
26	8.03	17.97	NFT ^②	na	na	na	na	na	na	na	na
32	8.03	23.97	8.03	na	na	na	na	na	na	na	na
38	8.03	29.97	8.03	na	na	na	na	na	na	na	na
44	8.03	35.97	8.03	na	na	na	na	na	na	na	na
50	8.03	41.97	8.03	na	na	na	na	na	na	na	na
56	8.03	47.97	8.03	19.5	36.5	NFT only ^②		21.38	34.62	NFT only ^②	
62	na	na	na	19.5	42.5	13.78	48.22	21.38	40.62	13.78	48.22
68	na	na	na	19.5	48.5	13.78	54.22	21.38	46.62	13.78	54.22
74	na	na	na	19.5	54.5	13.78	60.22	21.38	52.62	13.78	60.22

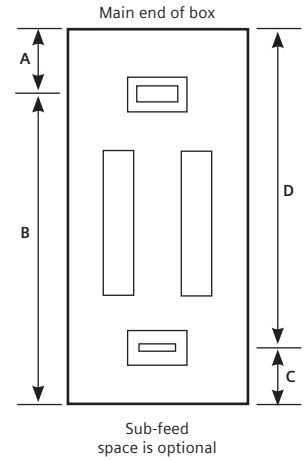

① Bottom Feed 400A distance is different due to breaker orientation.
 ② For NFT panels (Non-Feed-thru) - these values are not appropriate.

Type 1 Box

Box is symmetrical

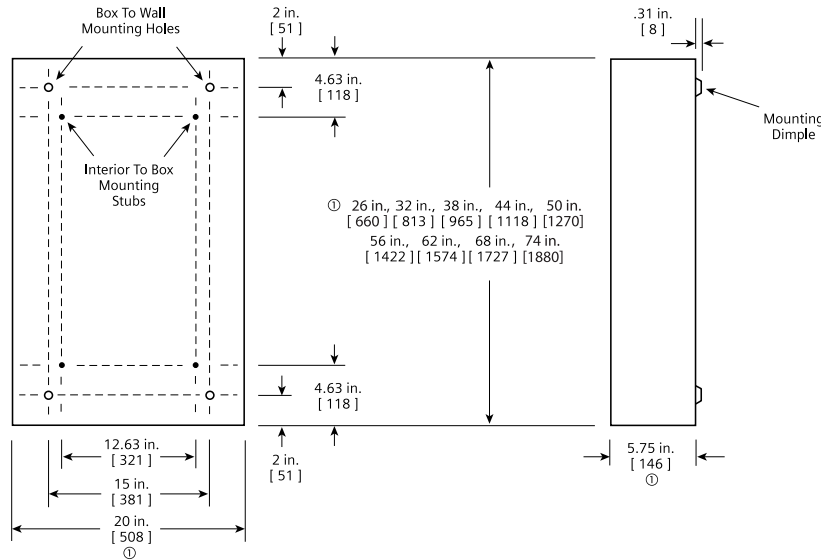

Flush Mounting

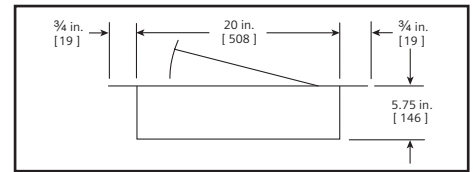

Type 3R and 3R/12 Box

Note: 3R boxes 50" h and larger include two "T" handles.

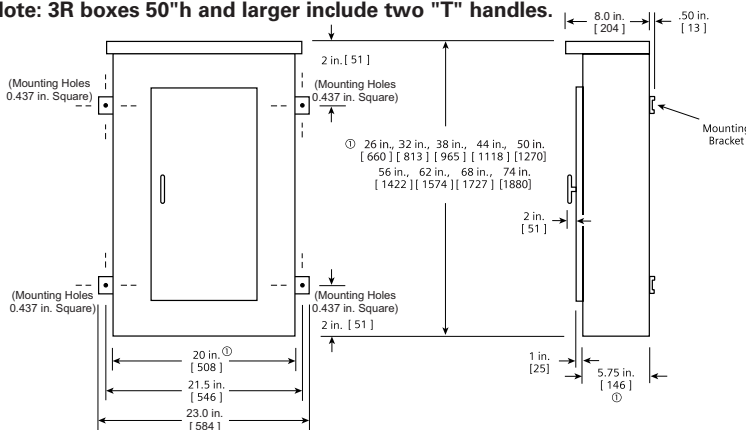

① Dimensions are interior of the box. Add 5/8" to width for absolute dimension. Add 1/8" to height for absolute dimension.
 Dimensions shown in inches and millimeters [].

Panelboards

Enclosures Types

Introduction

Enclosures

Type 1

Primarily indoor use: Box and front needed for complete enclosure.



Type 3R

Outdoor use primarily to provide a degree of protection against rain, sleet, and damage from external ice formation.



Type 12 (Siemens 3R/12)

These enclosures for Lighting Panels are useable as Type 12 or Type 3R by adding the gasket shown around the door.



(Siemens 3R/12 panelboard products meet this requirement)

Type 4 or 4X

Indoor or outdoor use primarily to provide a degree of protection against splashing water, corrosion, windblown dust and rain, hose-directed water, and damage from external ice formation.



Note: Type 4 is painted steel. NEMA Type 4X is typically stainless or non-metallic.

Panelboards

Trim / Front

Dimensions



Standard Trim (FAS-Latch)
(14 Gage Standard)

(Into stock includes surface or flush versions of this style in chart on page 11.

Standard Trim (FAS-Latch) Typical Dimensions (Hinges available as shown on right side only)

(Typical 14 Gage Steel construction or approved equivalent)

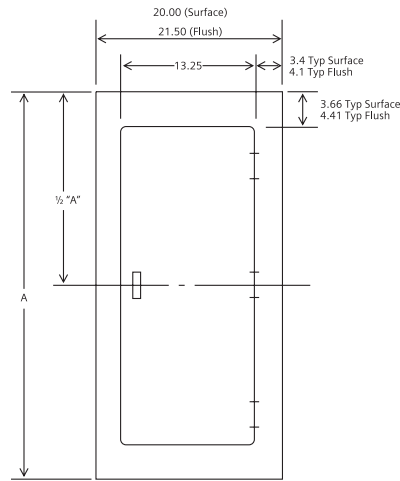

Box Size	Surface	Flush	# of Hinges
	A	A	
26	26	27.5	2
32	32	33.5	2
38	38	39.5	2
44	44	45.5	3
50	50	51.5	3

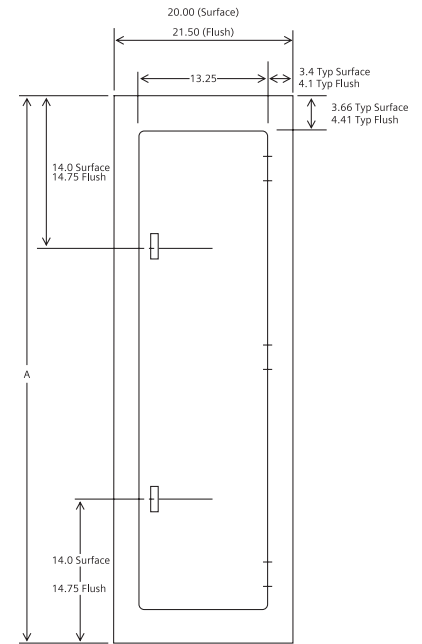

Box Size	Surface	Flush	# of Hinges
	A	A	
56	56	57.5	3
62	62	63.5	3
68	68	69.5	3
74	74	75.5	3

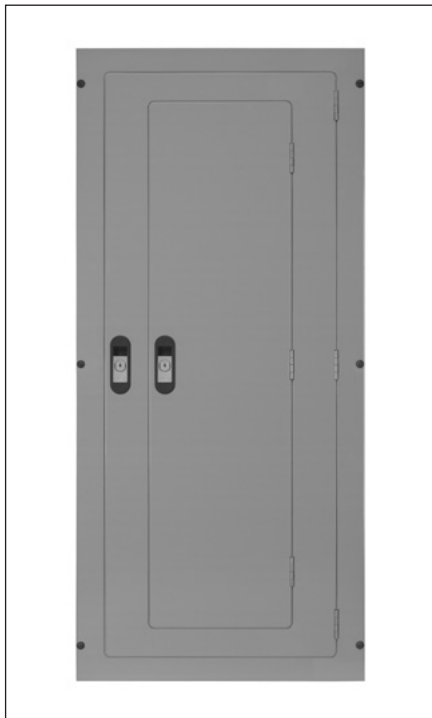

Door in Door Front
(14 Gage Standard)



Hinged to Box Front
(14 Gage Standard)

Also available

- Screw to Box Trim (14 Gauge Std.)
- Piano Hinge Trim (14 Gauge Std.)
 - a) Screw to box with Piano Hinge Door
 - b) Hinge to Box with Piano Hinge and Piano Hinge Door
 - c) Door-in-Door with Piano Hinge, Both Doors

Panelboards

Type P2 Panelboards

General

Features

Flexibility is the hallmark of the P2 panel and with the addition of the 3VA family of breakers in 2022 it is more capable than ever.

This panel offers a wide array of factory assembled options to meet almost all panel board applications up to 600A Maximum Bus ratings. With this design, the ability to mix breaker frames in unit space up to 250 amps will also meet many distribution panel requirements in a much smaller package.

Subfeed lugs (up to 400 amp) are only one of the options of this flexible panel.

Similar to Siemens P1 panel board, P2 is set up around 18, 30, 42, 54, 66, 78, and 90 circuit configurations in 6" increments of box size. It will also allow the user to configure the panel to the smallest possible size. Enclosures are shared with the P1 series as well and are from 26" to 74" high (in 6" increments to match interiors).

The P2 panel starts with 9" of unit space (18 circuits of 1" pole breakers). Breaker strap kits mounted in unit space can be mixed and matched to meet customer requirements for many types of breakers. All 1" pole breakers (BL, BQD, xGB, xGB2, ED & 3VA41 frames) are mounted in 3" or 6-pole increments. Breaker frames, above 125 amps, are mounted in 6" single breaker mounting kits (Sentron QR, FD and new 3VA series 3VA52/61/62 cover all requirements up to 250A).

- 3VA52/61/62 can be single mounted in 6" of unit space so FD will no longer be needed in sub-feed space.
- JD 400 amp will no longer be needed as main or sub-feed when new 3VA53/63 mains will be available.

Main Breakers from 100A frame to 600A frame can be configured as needed. 3VA mains (coming soon) will be the preferred main choice for most applications.

As an example of a minimum panel, (6) 20 amp 1-pole BL breakers (3" in height of unit space) and a 3-pole 225 amp QR breaker (6" of unit space) equalling 9" of unit space can be configured in a P2 panel without any extra provisions or space required.

Another unique feature of the P2 panel is that blank unit space can be added to allow for future expansions or modifications. - Any expansions or modifications must be in 3" or 6" increments for these kits and they can be mixed in unit space as needed.

Small frame breakers of the same frame can cross from one mounting kit to another if needed.

- BL/BQD 100A max. has 3" kits - 6-poles max.
- xGB/3VA41 125A max. has 3" kits - 6-poles max.
- xGB2 and ED 125A max. each have 3" kits also, but are no longer needed with the introduction of 3VA.

Larger frame breaker kits are single mount in 6" of unit space:

- QR 225A max. 2-pole or 3-pole have 6" kits.
- Changes in the field for unit space length for any 3" kit may require an addition deadfront center strip kit. Check with sales or the factory for field installable unit space strap kits.
- 3VA61 150A ETU only and 3VA52/62 250A max. 2-pole or 3-pole share the same 6" high kit.

Enclosures for P2

- Standard Type 1 enclosures are 20" wide x 5.75" deep. Box height is determined by main device and unit space. See charts for box height.
- Height: 26", 32", 38", 44", 50", 56",

62", 68" and 74" are standard sizes used for both P1 and P2

- Type 3R, 3R/12, 4X are typical examples of product available in 20" wide x 5.75" deep enclosures.
- For most applications, 24" wide and 7.75" deep variations are also available.

Main Lug / Main Breaker for P2

Voltage – 600V AC max./250V DC max.

Amperage

- Main Lug: 125 to 600 amp max.
- Main Breaker: 100 to 600 amp max.

Short circuit rating

- 200 kAIC max. symmetrical or equal to the lowest rated device installed unless a series rating is indicated.
- Panels with subfeed or feed-thru lugs without a main device*, circuit breaker or fusible unit, are limited to a three-cycle rating. The three-cycle rating for the P2 panel is limited to 22 kAIC.

*Note: The main device may be mounted remote from the panel.

Bussing – The P2 panel has more options to meet market requirements. The standard bussing is temperature rated aluminum. The rating is per the requirements of CSA C22.2 No.29 - the standard for panelboards. All aluminum bussing is tin-plated. Optional bussing for the P2 panel is copper.

The copper bus option for this panel is tin-plated as standard or silver.

Weight – Approximate

Total panelboard weight when filled with a normal quantity of breakers and accessories is about 3 lbs. (1 kg) per inch (54g per mm) of box height.

Gauge Steel of Boxes/Fronts, Surface and Flush

Dimensions in Inches (mm)		Gauge Steel		
H	W	Box	Front/Door	Type
26-74 (660-1880)	20 (508)	16 ^①	14 ^⑤	Type 1
26-74 (660-1880)	20 (508)	16 ^②	16/14 ^②	Type 3R/12
32-60 (813-1524)	20-36 (508-914)	14 ^③	14 ^⑤	Type 4
26-74 (660-1879)	20 (508)	14 ^④	14 ^⑥	Type 4X

① 16 Gauge is Standard (14 Gauge & 12 Gauge are optional)

② 15 Gauge Steel Can with 14 Gauge Door or Similar Approved Construction

③ No Optional Gauge available

④ 304SS 14 Gauge Std., 316SS 14 Gauge optional

⑤ FAS-Latch is 14 GA only.

Screw-to-Box, Hinge-to-Box, Door-in-Door (14 GA Std./12 GA Std. or 10 GA Optional)

STB/HTB/DND with Piano Hinge (14 GA Std./12 GA Optional)

Panelboards

Distributor Stock - Type P2 Main Lug Only

Reference

Interior Numbering System

Type P2 unassembled panelboards are available as main lug only and come with provisions for the branch breaker type selected.

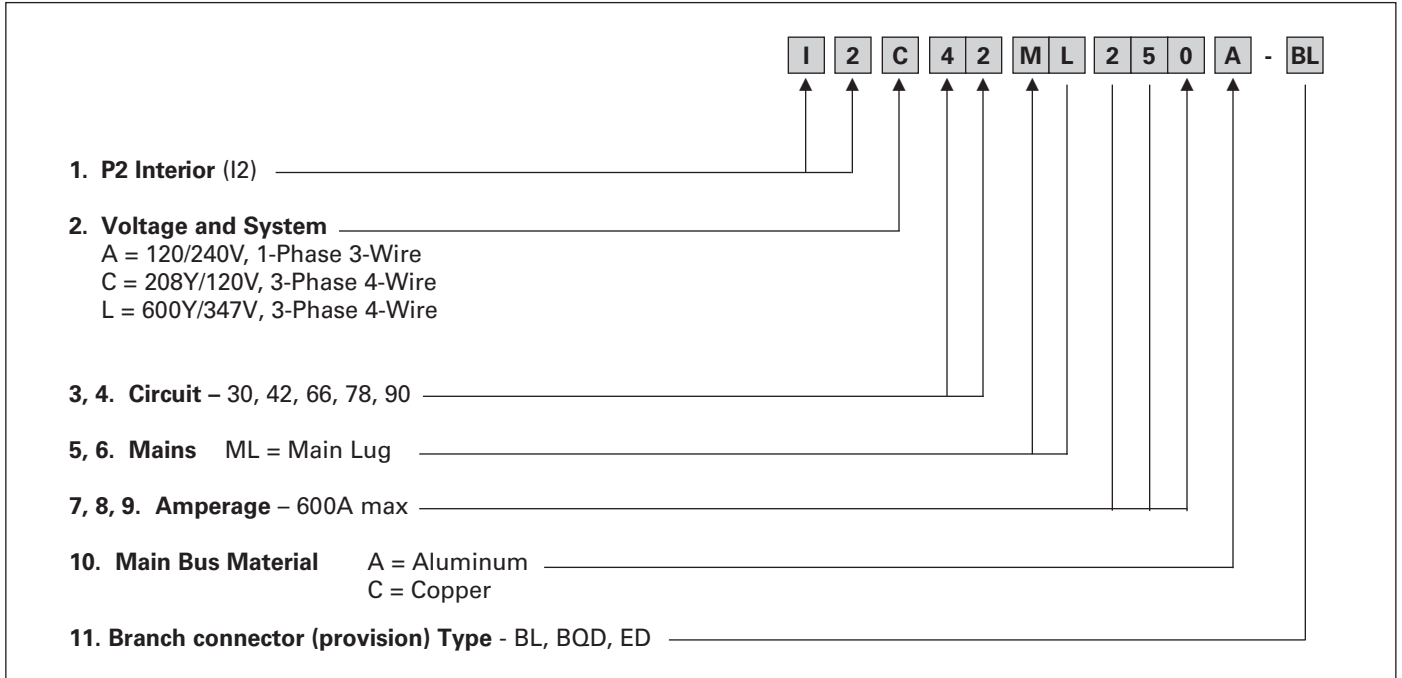

Branch Breakers

Panel Type	Voltage (Max.)	Breaker Type	Power Product Catalogue Page
P2	240	BL, BLH, HBL, BQD	See section 5
	600/347	BQD6, ED6	

Panelboards

Distributor Stock - Type P2 Main Lug Only

Selection

Interior, Box and Trim Selection
600A Max. — 20" Wide x 5.75" Deep

- Determine voltage, system, amperage and type of branch breaker connectors to select the appropriate Interior from the table below.
- Select the type of box and trim needed.
- List required branch circuit breakers: Type BL, BQD or ED breakers.

Type P2 Unassembled Panelboards

Interiors Only - Less Branch Breakers				Boxes			Trim	
Amperes Rating Mains	Max. No. of Circuits	Provision Type	Main Lug + provisions	Height - Inches (mm)	Type 1	Type 3R/12 ^①	Surface	Flush ^②
1-Phase, 3-Wire				120/240V				
250	66	BL/BQD	I2A66ML250A-BL	56 (1422)	B56	WP56	S56B	F56B
	78		I2A78ML250A-BL	62 (1575)	B62	WP62	S62B	F62B
400	42	BL/BQD	I2A42ML400A-BL	50 (1270)	B50	WP50	S50B	F50B
	66		I2A66ML400A-BL	62 (1575)	B62	WP62	S62B	F62B
3-Phase, 4-Wire				208Y / 120V				
250	42	BL/BQD	I2C42ML250A-BL	44 (1118)	B44	WP44	S44B	F44B
	66		I2C66ML250A-BL	56 (1422)	B56	WP56	S56B	F56B
	78		I2C78ML250A-BL	62 (1575)	B62	WP62	S62B	F62B
400	42	BL/BQD	I2C42ML400A-BL	50 (1270)	B50	WP50	S50B	F50B
	66		I2C66ML400A-BL	62 (1575)	B62	WP62	S62B	F62B
	78		I2C78ML400A-BL	68 (1727)	B68	WP68	S68B	F68B
	90		I2C90ML400A-BL	74 (1880)	B74	WP74	S74B	F74B
600	66	BL/BQD	I2C66ML600A-BL	62 (1575)	B62	WP62	S62B	F62B
3-Phase, 4-Wire				600Y / 347V				
250	30	ED	I2L30ML250A-ED	38 (965)	B38	WP38	S38B	F38B
	42	ED	I2L42ML250A-ED	44 (1118)	B44	WP44	S44B	F44B
	66	BQD6	I2L66ML250A-BQD	56 (1422)	B56	WP56	S56B	F56B
		ED	I2L66ML250A-ED	56 (1422)	B56	WP56	S56B	F56B
400	42	BQD6	I2L42ML400A-BQD	50 (1270)	B50	WP50	S50B	F50B
		ED	I2L42ML400A-ED	50 (1270)	B50	WP50	S50B	F50B
	66	BQD6	I2L66ML400A-BQD	62 (1575)	B62	WP62	S62B	F62B
		ED	I2L66ML400A-ED	62 (1575)	B62	WP62	S62B	F62B
78	BQD6	I2L78ML400A-BQD	68 (1727)	B68	WP68	S68B	F68B	
	ED	I2L78ML400A-ED	68 (1727)	B68	WP68	S68B	F68B	
90	BQD6	I2L90ML400A-BQD	74 (1880)	B74	WP74	S74B	F74B	
	ED	I2L90ML400A-ED	74 (1880)	B74	WP74	S74B	F74B	
600	66	BQD6	I2L66ML600A-BQD	62 (1575)	B62	WP62	S62B	F62B
		ED	I2L66ML600A-ED	62 (1575)	B62	WP62	S62B	F62B

① Hinged door included with type 3R/12 enclosures.
 ② Flush trims extend 3/4" beyond each side of the base

box dimensions.

Panelboards

Type P2 Panelboards

Selection/Dimensions

Standard Circuit P2 Panels (Neutral Configurations for up to 54 circuits max.)

Table below shows minimum Box Size required for the Unit Space indicated with the Main Option at the top of each Column.

- Adding other options generally will add to the box Height when configured in COMPAS. Also, there may be cost adders with each option.
- The maximum number of 1" circuits supported is shown at the bottom of each column in brackets. [54p] = max 54 poles of 1" circuits supported (BL, BT, BQD, ED, xGB, xGB2, 3VA41).
- Unit space is available in 9", 15", 21", 27", 33", 39", and 45" sizes.
- Within unit space listed, the neutral will support up to 54 circuits.
- When more than 54 circuits are required, COMPAS will configure with larger Extended Circuit Neutral.
- Box sizes available: 26", 32", 38", 44", 50", 62", 68", 74"

Circuit P2 Panels with Standard Line Side Lugs Unit Space (starting with 9" and adding 6" increments) "A" Dimension

Panel Type →		Main Lugs			Main Breakers																		
Bus amps max.		250A		600A	250A										600A								
ML/MB amps		125	250	400-600	100	125 max.					225 max.		250 max.			400 max.			600 max.				
"B" Dim. Box Height	Type / Family	→			BL	xGB	ED		CED	QR		3VA52/61/62		FD		CFD	3VA53	JD	CJD	3VA54	LD	CLD	
	Horiz.	→			H	H	H		H	H		H		H		V	V	V	V	V	V	V	
	Vertical	→						V ^①			V ^①		V ^①		V ^①	V	V	V	V	V	V	V	
26	values to right are in inches of unit space	—	—	—	9	9	9	—	—	—	—	—	—	—	—	—	—	—	—	—	—	—	
32		9	9	—	15	15	15	9	9	9	—	9	—	9	—	—	—	—	—	—	—	—	
38		15	15	9	21	21	21	15	15	15	9	15	—	15	—	—	—	—	—	—	—	—	—
44		21	21	15	27	27	27	21	21	21	15	21	9	21	9	—	—	—	—	—	—	—	—
50		27	27	21	33	33	33	27	27	27	21	27	15	27	15	9	9	9	—	—	—	—	—
56		33	33	27	39	39	39	33	33	33	27	33	21	33	21	15	15	15	—	9	9	—	—
62		39	39	33	45	45	45	39	39	39	33	39	27	39	27	21	21	21	9	15	15	9	—
68	45	45	39	—	—	—	45	45	45	39	45	33	45	33	27	27	27	15	21	21	21	15	
74	—	—	45	—	—	—	—	—	—	45	n/a	39	n/a	39	33	33	33	21	27	27	21	21	
Max. 1-pole brk ^②		[54p]			[54p]					[54p]		[54p]			[54p]			[42p]	[42p]	[54p]	[42p]	[42p]	

H = horizontally mounted

V = vertically mounted

① The vertical main breaker application for ED, QJ, QR, FD and 3VA52/61/62 adds 6" of box height.

② Generally the count varies depending on neutral connections available and configuration of the panel. Use this value as general rule. Also, see tables on page <?>.

Panelboards

Type P2 Panelboards

Selection

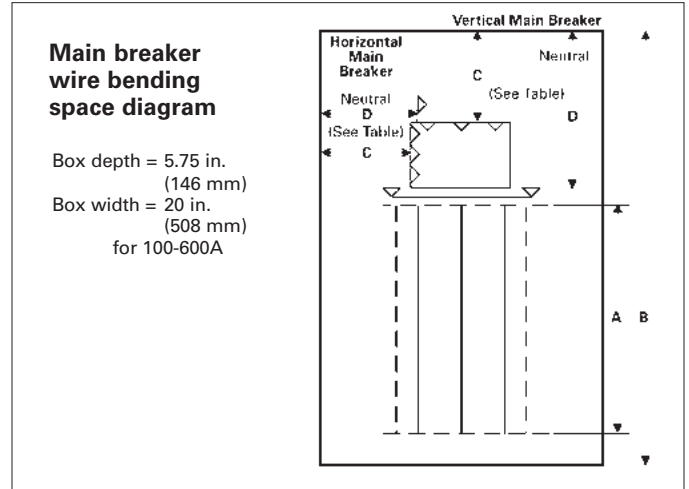
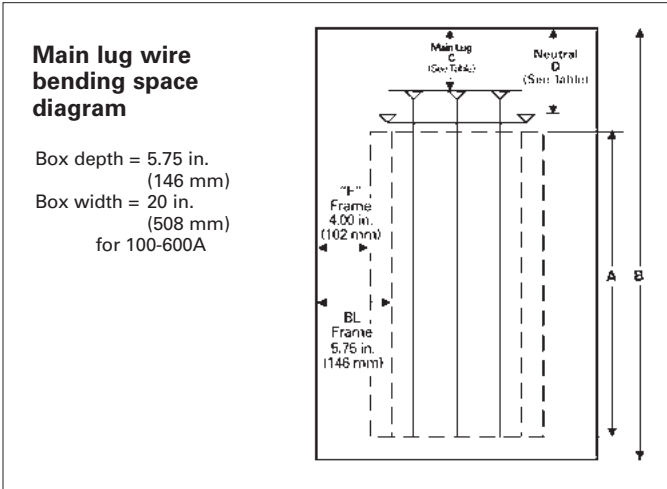

Standard Circuit P2 Panels

Main Breaker Wire Bending

Panel Amps	Standard Circuits (up to 54 1" module branch poles)			
	Breaker Frames	Mounting	C ^① (Main)	D ^① (Neutral)
100	BL	Horiz.	5.75	8.00
	BQD	Horiz.	5.13	8.00
125	3VA41 (coming soon)	Horiz.	4.63	8.00
	xGB, GB2	Horiz.	4.63	8.00
	ED	Horiz.	4.00	8.00
	ED	Vert.	6.56	11.13
225	QR	Horiz.	5.00	7.00
	QR	Vert.	10.06	16.69
250	3VA52 (coming soon)	Horiz.	6.83	7.29
	3VA61/62 (coming soon)	Horiz.	6.29	7.29
	3VA52 (coming soon)	Vert.	17.07	22.75
	3VA61/62 (coming soon)	Vert.	16.56	22.75
	FD	Horiz.	5.00	7.00
	FD	Vert.	13.25	22.72
400	3VA53/63 (1) 600 Lug (coming soon)	Vert.	14.73	25.00
	3VA53/63 (2) 600 Lug (coming soon)	Vert.	12.30 ^②	25.00
	JD	Vert.	15.38	25.00
600	3VA54/64 (2) 600 Lug	Vert.	12.30	29.00 ^③
	LD	Vert.	15.38	23.00 ^③

Main Lug Connectors

Panel Amps	Standard Circuits (up to 54 1" module branch poles)		
	Standard Connectors	C ^①	D ^①
125	(1) #14-2/0	12.62	14.19
250	(1) #6 AWG - 350 kCMIL	11.75	10.72
400	(1) #4 AWG - 600 kCMIL or (2) #6 - 250 kCMIL	14.00	13.09
600	(2) #4 AWG - 500 kCMIL	14.00	11.00

① Refer to diagrams at the top of this page.

② Wire bending with std neut with AL/CU lugs. Same for JD.

Panelboards

Type P2 Panelboards

Selection/Dimensions

Branch Breaker Side Gutters Inches (mm)

← 24" (610mm) box width reference →					
← 20" (508mm) box width reference →				20" W box	24" W box
Ref code	Breaker type or Family		Ref code	Gutter Space inches (mm)	Gutter Space inches (mm)
← A →	BL, BLH,HBL	BL, BLH,HBL	← A →	= 5.750 (146)	7.750 (197)
← B →	BLF2, BLHF2, HBLF2, BLFB, BLHFB	BLF2, BLHF2, HBLF2, BLFB, BLHFB	← B →	= 5.125 (130)	7.125 (181)
	BQD, BQD6	BQD, BQD6			
← C →	NGB, HGB, LGB	NGB, HGB, LGB	← C →	= 4.625 (117)	6.625 (168)
	NGB2, HGB2, LGB2	NGB2, HGB2, LGB2			
← D →	3VA41	3VA41	← D →	= 4.625 (117)	6.625 (168)
← E →	ED4, ED6	ED4, ED6	← E →	= 4.000 (102)	6.000 (152)
	HED4, HHED6	HED4, HHED6			
← F →	QR2, QRH2, HQR2, HQR2H (Single Mounted)		← F →	= 5.000 (127)	7.000 (178)
← G →	3VA52 (w/1-port lug) (Single Mount)		← G →	= 6.83(174)	8.83(225)
← H →	3VA61/62 (w/1-port lug) (Single Mount)		← H →	= 6.29(160)	8.29(211)

P2 Branch Neutral Connections^①

Wire Range	Maximum Connections		Max. Amp reference			
	Std. Panels					
Note: Large Branch is >125A frame size.	Neutral with 1/0 step lugs (varies with config.)	AL Cable 60C	CU Cable 60C	AL Cable 75C ^②	CU Cable 75C	
Connector Wire Range below:						
#14-#6	28	40	55	50	65	
#14-1/0	28	n/a	n/a	120	150	
#6-350 kCMIL	0-3	n/a	n/a	250	310	
(1) #4-600 kCMIL or (2) #6-250 kCMIL (for subfeed breaker or as needed)	0-1	n/a	n/a	340 410	420 510	
Total connections max. =	56-60					

① Reference info: Neutral Lugs are rated for 75°C cable. When running a circuit to a load, the same type of wire should be used on the phase (breaker) and neutral connections in the panel.

- a) Cables should be sized per CEC and the 75°C column.
- b) Customer can choose to use 90°C cable if sized as if it is 75°C.
- c) Some 100% rated circuit breakers require the use of 90°C cable sized per the 75°C column. Refer to the Markings on the breaker and use the appropriate cable.
- d) Some Circuit breakers 100A or less are marked as being suitable for 60°C, 75°C or 60/75°C cable. Refer to the Markings on the breaker and use the appropriate cable.
- ② The branch neutral can already use 75°C, but when running a circuit to a load, the same

type of wire should be used on the phase (breaker) and neutral connections in the panel. All of our breakers are rated for 75°C (smaller dia per amp rating than 60°C wire). - UL assumes 75°C or higher rating for wires at or above 1/0 size.

Panelboards

Type P2 Panelboards

Selection

P2 Main Circuit Breakers and Subfeed

P2 Main Circuit Breakers ^④ and Subfeed					2-Pole and 3-Pole							For Horizontal or Vertical Mounted Main Option – add X" to Box Height	Horiz. mount box size Min. w/ 9" of unit space	Vertical mount box size Min. w/ 9" of unit space	Extended Circuits Available	Horiz. mount box size Ext. Ckts w/ 33" unit space	Vertical mount box size Ext. Ckts w/ 33" unit space	Sub-feed outside of unit space – add X" to Box Height			
Amp Rating	Trip Type	Breaker Family	Main Breaker Code	Breaker Type	Max IR (kA) at														Amp Ratings Available		
					120/240V	240V	480Y/277V	480V	600Y/347V	600V	125/250V DC									250V DC ^①	
100	Thermal Magnetic	BL	BL	BL	10	10	–	–	–	–	–	–	15-100	Horiz. Only	26	n/a	n	n/a	n/a	n/a	
			BH	BLH	22	22	–	–	–	–	–	–	–	15-100	Horiz. Only	26	n/a	n	n/a	n/a	n/a
			HB	HBL	65	65	–	–	–	–	–	–	–	–	15-100	Horiz. Only	26	n/a	n	n/a	n/a
		BQD	BQ	BQD ^②	–	65	14	–	10	–	14	–	15-100	Horiz. Only	26	n/a	y	56	n/a	n/a	
125	Thermal Magnetic	Sentron GB	NB	NGB	–	100	25	–	14	–	14	–	15-125	Horiz. Only	26	n/a	y	56	n/a	n/a	
			G2	HGB	–	100	35	–	14	–	14	–	–	15-125	Horiz. Only	26	n/a	y	56	n/a	n/a
			G3	LGB	–	100	65	–	14	–	14	–	–	15-125	Horiz. Only	26	n/a	y	56	n/a	n/a
		Sentron GB2	G4	NGB2	–	100	–	25	14	–	14	–	–	15-125	Horiz. Only	26	n/a	y	56	n/a	n/a
			G5	HGB2	–	100	–	35	22	–	14	–	–	15-125	Horiz. Only	26	n/a	y	56	n/a	n/a
			G6	LGB2	–	100	–	65	65	–	14	–	–	15-125	Horiz. Only	26	n/a	y	56	n/a	n/a
		Sentron ED	E4	ED4	–	65	–	18	–	–	–	–	30	15-125	Vert.= Std. +6"	26	32	y	56	62	n/a
			E6	ED6 ^③	–	65	–	25	–	18	–	–	30	20-125	Vert.= Std. +6"	26	32	y	56	62	n/a
			H4	HED4	–	100	–	42	–	–	–	–	30	15-125	Vert.= Std. +6"	26	32	y	56	62	n/a
		3VA41	HA	HHED6	–	100	–	65	–	18	–	–	–	15-50	Vert.= Std. +6"	26	32	y	56	62	n/a
			CE	CED6	–	200	–	200	–	100	–	–	–	50-125	Vert. Only Std. +6"	n/a	32	y	62	n/a	n/a
			V1	SEAB	–	65	–	25	14	–	–	–	–	15-125	Horiz Only	26	n/a	y	56	n/a	n/a
V2	MEAB	–	85	–	35	18	–	–	–	–	–	15-125	Horiz Only	26	n/a	y	56	n/a	n/a		
	V3	HEAB	–	150	–	65	25	–	–	–	–	15-125	Horiz Only	26	n/a	y	56	n/a	n/a		
150	Electronic (Solid state)	3VA61 (ETU350 LSI std)	W2	MDAE	–	100	–	35	–	18	–	–	16-150	Vert.= Std. +6"	38	44	y	68	74	n/a	
			W3	HDAE	–	100	–	65	–	22	–	–	16-150	Vert.= Std. +6"	38	44	y	68	74	n/a	
			W4	CDAE	–	200	–	100	–	35	–	–	–	16-150	Vert.= Std. +6"	38	44	y	68	74	n/a
			W5	LDAE	–	200	–	150	–	50	–	–	–	16-150	Vert.= Std. +6"	38	44	y	68	74	n/a
225	Thermal Magnetic	Sentron QR	QR	QR2	–	10	–	–	–	–	–	–	100-225	Vert.= Std. +6"	32	38	y	56	62	n/a	
			Q4	QRH2	–	25	–	–	–	–	–	–	–	100-225	Vert.= Std. +6"	32	38	y	56	62	n/a
			Q5	HQR2	–	65	–	–	–	–	–	–	–	100-225	Vert.= Std. +6"	32	38	y	56	62	n/a
			Q6	HQR2H	–	100	–	–	–	–	–	–	–	100-225	Vert.= Std. +6"	32	38	y	56	62	n/a
250	Thermal Magnetic	Sentron FD	FX, FD	FXD6-A, FD6-A	–	65	–	35	–	22	–	30	70-250	Vert.= Std. +6"	38	44	y	68	74	⑤	
			H2, HF	HFXD6, HFD6	–	100	–	65	–	25	–	30	70-250	Vert.= Std. +6"	38	44	y	68	74	⑤	
			CF	CFD6-A	–	200	–	200	–	100	–	50	70-250	Vert. Std. +12"	38	50	n	n/a	n/a	n/a	
250	Thermal Magnetic	3VA52 (with TM230 trip)	VA	MFAE	–	85	–	35	–	18	–	60	100-250	Vert.= Std. +6"	38	44	y	68	74	n/a	
			VB	HFAS	–	100	–	65	–	25	–	85	100-250	Vert.= Std. +6"	38	44	y	68	74	n/a	
			VC	CFAS	–	200	–	100	–	35	–	100	100-250	Vert.= Std. +6"	38	44	y	68	74	n/a	
	Electronic (Solid state)	3VA62 (ETU350 LSI std)	WA	MFAE	–	100	–	35	–	18	–	–	100-250	Vert.= Std. +6"	38	44	y	68	74	n/a	
WB			HFAE	–	100	–	65	–	22	–	–	100-250	Vert.= Std. +6"	38	44	y	68	74	n/a		
WC			CFAE	–	200	–	100	–	35	–	–	100-250	Vert.= Std. +6"	38	44	y	68	74	n/a		
WD			LFAE	–	200	–	150	–	50	–	–	100-250	Vert.= Std. +6"	38	44	y	68	74	n/a		

Vertically Mounted Main Breaker (available in 2-pole or 3-pole)

Ampere Rating	Breaker Type(s)	Unit Space (in.)
100	ED4, ED6, HED4	6
225	FXD6, FD6, HFD6, QR2, QRH2, HQR2, HQR2H	6

Subfeed Breakers (available in 2-pole or 3-pole)

Breaker Type	Mounting Position When Used as Subfeed Breaker	Ampere Ratings For Load	Maximum Interrupting Rating (kA) Symmetrical		
			240V AC	480V AC	600V AC
FD6 ^⑥ , FXD6	Twin	70–250	65	35	22
HFD6 ^⑥ , HFXD6	Twin	70–250	100	65	25
JD6 ^⑥ , JXD6	Single	200–250	65	35	25
HJD6 ^⑥ , HJXD6	Single	200–250	100	65	35

① Interchangeable trip main breakers are mounted at top of panel only.
② Vertically mounted.

③ Twin mounted subfeed breakers are mounted at the bottom of panelboard only and adds 24" to the panel height.

④ Subfeed breaker is mounted at bottom of panelboard only. 250 amp subfeed breaker adds 24" to the panel height. (Only for use with MLO)

Panelboards

P2 Branch Circuit Breakers

Selection

Branch Circuit Breakers

Max. Amp Rating	Bolt-On Breaker Type	Amps	Availability			Maximum Interrupting Rating (kA)						
			1-Pole	2-Pole	3-Pole	120V AC	120/240V AC	240V AC	277V AC	480V AC	600V AC	250V DC
70	BQD6	15-70	✓	✓	✓	65	65	65	—	—	10	—
100	BL	15-60	✓	✓	✓	10	—	—	—	—	—	—
		70	✓	✓	✓	—	10	—	—	—	—	—
		80-100	✓	✓	✓	—	—	10	—	—	—	—
	BLH	15-60	✓	✓	✓	—	22	—	—	—	—	—
		70	✓	✓	✓	—	22	—	—	—	—	—
		80-100	✓	✓	✓	—	—	22	—	—	—	—
	HBL BLR (240V)	15-55	✓	✓	✓	—	65	—	—	—	—	—
		60-100	✓	✓	✓	—	65	—	—	—	—	—
		15-60 70-100	— —	✓ ✓	— —	— —	— —	10 10	— —	— —	— —	— —
	BLE (GFCI)	15-30	✓	✓	—	10	—	—	—	—	—	—
		40-60	—	✓	—	—	10	—	—	—	—	—
	BLEH	20-30	✓	—	—	22	—	—	—	—	—	—
		15-60	✓	✓	—	—	22	—	—	—	—	—
BLF (GFCI)	15-30	✓	✓	—	10	—	—	—	—	—	—	
	40-60	✓	✓	—	—	10	—	—	—	—	—	
BLHF (GFCI)	15-30	✓	✓	—	22	—	—	—	—	—	—	
	40-60	✓	✓	—	—	22	—	—	—	—	—	
HBLF2 (GFCI)	15-30	✓	—	—	65	—	—	—	—	—	—	
BAF BAFH	15-20	✓	✓	—	10	—	—	—	—	—	—	
	15-20	✓	✓	—	22	—	—	—	—	—	—	
BQD	15-60	✓	✓	✓	—	65	—	14	—	—	14	
	70-100	✓	✓	✓	—	65	—	—	14	—	14	
125	NGB2	15-60	✓	✓	✓	100	100	100	25	25	14	14 ^④
		70-100	✓	✓	✓	100	100	100	25	25	14	14 ^④
		110-125	—	✓	✓	100	100	100	25	25	14	14 ^④
	HGB2	15-60	✓	✓	✓	100	100	100	35	35	22	14 ^④
		70-100	✓	✓	✓	100	100	100	35	35	22	14 ^④
		110-125	—	✓	✓	100	100	100	35	35	22	14 ^④
	LGB2	15-60	✓	✓	✓	100	100	100	65	65	25	14 ^④
		70-100	✓	✓	✓	100	100	100	65	65	25	14 ^③
		110-125	—	✓	✓	100	100	100	65	65	25	14 ^③
	ED4	15-60	✓	✓	✓	65	—	—	22	—	—	—
		70-100	✓	✓	✓	—	—	65	—	18	—	30
		110-125	—	✓	✓	—	—	65	—	18	—	—
	ED6	15-60	—	✓	✓	—	—	65	—	25	18	30
70-100		—	✓	✓	—	—	65	—	25	18	—	
110-125		—	✓	✓	—	—	65	—	25	18	—	
HED4 ^①	15-60	✓	✓	✓	—	—	65	—	42	18	30	
	70-100	✓	✓	✓	—	—	65	—	42	18	—	
	110-125	—	✓	✓	—	—	65	—	42	18	—	
CED6 ^②	15	—	—	✓	—	—	200	—	—	100	—	
	20-125	—	✓	✓	—	—	200	—	—	100	—	
225	QR2	100-225	—	✓	✓	—	—	10	—	—	—	
	QRH2	100-225	—	✓	✓	—	—	25	—	—	—	
	HQR2	100-225	—	✓	✓	—	—	65	—	—	—	
	HQR2H	100-225	—	✓	✓	—	—	100	—	—	—	

Branch Neutral Connections

Wire Range	Max. Number of Connections	Max. Amp ^②
#14-#6	26	65
#14-1/0	28	125
#6-350 kcmil	3	250
(1) #4-600 kcmil or (2) #6-250 kcmil	1	400

① 1-Pole HED 4 15-30A Rated 65kA 35 through 100A Rated 25kA.

② Based on 75 degree copper.

③ 2-pole only (or) two outer poles of 3-pole breaker.

④ CED6 breaker can be used in 400A panel with copper bussing only.

Panel enclosure required is 24" (610mm) wide.

NOTE: QR Breakers are single mounted in unit space and take 6" of unit space. Limited to (4) per panel max. BL, HBL, BLH and BQD breakers are mounted in common mountings in 3" or (6) pole increments. ED4, ED6 and HED4 breakers are mounted in common mountings in 3" or (6) pole increments.

Panelboards

Type P2 Panelboard Modifications and Additions

Selection

Enclosure Modifications

Description
Type 1 with gasket Type 1 with dripshield Type 3R - Waterproof and silicone free Type 3R/12 - Dustproof Type 4/4X - Standard type 304 Stainless Steel Type 4/4X - Type 316 Stainless Steel Wider enclosure - 24", 30" or 36" wide
Hinged trim Piano hinged trim Trim with padlock Door-in-door trim Screw to the box trim Trim with gasketed door Stainless steel trim
Trim mounted devices (Devices mounted into a 10" minimum box extension) <ul style="list-style-type: none"> • Pilot lights • Toggle switches • Push buttons
Painted boxes Custom colors Increase gauge trims and boxes Stainless steel trims and boxes, Type 1

Meters

(Contact sales for pricing and application engineering for space requirements)

Panel Skirts

See page 10-64

Panel Bus Modifications

Bus Material

Represented by "A", "C" or "E" in the 11th digit of the catalogue number.

Standard bussing is tin plated Al, alternate bus bar material can be selected:

- Tin plated copper
- Silver plated copper - optional

Subfeed and Feed-Thru (for 2-pole or 3-pole)

Ampere Rating	Connector Cu/Al Wire Range	Unit Space (inches)
100/125	(2)—#12 AWG - 2/0 AWG	6
225/250	(2)—#6 AWG-350 kcmil	6
400	(4)—250 kcmil (2)—600 kcmil	6

Subfeed (Double) Lugs for Main Lug Panelboards Only

100/125	(2)—#12 AWG - 2/0 AWG	6
225/250	(2)—#6 AWG-350 kcmil	6
400	(4)—250 kcmil (2)—600 kcmil	6

Feed-Thru Lugs – Cannot be used in conjunction with SPD or Subfeed Breakers (200% Neutral not available)

Amp Rating	Type	Connector Wire Range
125	Al Mechanical	(1) #6 AWG - 2/0 AWG Al/Cu
	Cu Mechanical	(1) #6 AWG - 350 kcmil Cu
	Compression	(1) #6 AWG - 350 kcmil Al/Cu
250	Al Mechanical	(1) #6 AWG - 350 kcmil Al/Cu
	Cu Mechanical	(1) #6 AWG - 350 kcmil Cu
	Compression	(1) #6 AWG - 350 kcmil Al/Cu
400	Al Mechanical	(1) #2 AWG - 600 kcmil Al/Cu and (1) 1/0 AWG - 250 kcmil Al/Cu
	Cu Mechanical	(1) 1/0 AWG - 600 kcmil or (2) 1/0 AWG - 4/0 AWG
	Compression	(1) 250 kcmil - 600 kcmil Cu or (2) #6 AWG - 350 kcmil Al/Cu
600	Al Mechanical	(2) #2 AWG - 600 kcmil Al/Cu
	Cu Mechanical	(2) #2 AWG - 600 kcmil Cu
	Compression	(2) #6 AWG - 350 kcmil Al/Cu (2) 400 kcmil - 600 kcmil Al or (2) 400 kcmil - 500 kcmil Cu

Increase Capacity Neutral up to 200% (N/A on FeedThru Lugs & Subfeed Lugs)

Main Bus Amps
125
250
400
600

See page 10-37 for unit space adders and compatibility with other options.

(Devices mounted and wired to the trim should also have hinged trim specified)

Bus mounted SPD

See Section 9

TPS3 01

- Bus connected
- Internally mounted (30A breaker required to feed SPD)
- Externally mounted in a 15" high aux. enclosure (30A breaker required to feed SPD)

TPS3 09

- Internally mounted (20A breaker required to feed SPD)
- Externally mounted (20A breaker required to feed SPD)

TPS3 12

- Externally mounted (40A breaker required to feed SPD)

Service Entrance Label

Type P2 Panelboards are factory labeled "SUITABLE FOR USE AS SERVICE ENTRANCE EQUIPMENT" when identified as "Service Entrance" at the time of order entry. For regulations governing this feature, please consult CEC, CSA or local electrical authorities.

Grounding of Panelboards

Ground Bars except for brazed to box are shipped with the panel interior factory mounted.

- Non-Insulated Equipment Ground Bar
- Copper Non-Insulated Ground Bar
- Al Insulated Equipment Ground Bar
- Cu Insulated Equipment Ground Bar

Shunt Trip on Main or Branch

BL, BLH, HBL, NGB, xGB2, ED6, HED4, uses 1" unit space for shunt trip. All others may be used on mains or subfeeds.

Contactors Mains or Submain*

Asco 920 through 225 amps – adds 12" unit space as main, 15" unit space as submain

External with manufacture supplied enclosure
Siemens LEN through 30 amps - adds 6" as main; 18" for up to 100A submain and 21" for 200A. 7.75" depth cans for up to 100A and 10" depth cans for 200A.

Branch and Main Breaker Accessories

See breaker section of this catalog.

- Handle blocks
- Handle locks
- Aux. Contacts®
- UVR®

① Accessories on 1" pole breakers (BL, BQD, ED) will take unit space.

Panelboards

Type P2 Panelboard Standard Modifications and Additions

Selection

Box Size Additions for Optional Features

Options	Main Lugs				Main Breakers											
	125A	250A	400A	600A	125A Horiz. BL, BQD, ED, xGB	125A Horiz. CED	125A Vert. ED	225A Horiz. QR	225A Vert. QR	225A Horiz. FD	250A Vert. FD	250A Vert. CFD	400A JD	400A CJD	600A LD	600A CLD
*Min. Box Size	26"	32"	38"	38"	26"	32"	32"	32"	38"	38"	44"	50"	50"	62"	56"	62"
200% Neutral (lug type)	0	0	6 (all)	6 (all)	0	0	0	N/A	0	N/A	0	0	0	0	0	0
Std. Lugs (100% Neut. PNL)	0	0	0	0	0	0	0	0	0	0	0	0	0	0	0	0
CU Lugs (100% Neut. PNL)	6	6	6	0	N/A	N/A	0	N/A	0	N/A	0	0	0	0	0	0
Comp Lugs (100% Neut. PNL)	6	6	6	6	N/A	N/A	0	N/A	0	N/A	0	0	0	0	0	0
Feed-thru Standard Lugs	6	6	12	12	6	6	6	N/A	6	N/A	6	6	12	12	12	12
Feed-thru Cu Lugs Feed-thru	6	6	12	N/A	N/A	N/A	6	N/A	6	N/A	6	6	12	12	N/A	N/A
Comp Lugs	6	12	12	N/A	N/A	N/A	6	N/A	6	N/A	12	12	12	12	N/A	N/A
Subfeed Standard Lugs	0	6	6	N/A	—	—	—	—	—	—	—	—	N/A	—	—	—
(1) FD Subfeed (Horizontal Mtg.)	N/A	12	12	12	N/A	N/A	N/A	N/A	N/A	12	12	12	12	12	12	12
(2) FD Subfeed (Vertical Mtg.)	N/A	24	24	24	N/A	N/A	N/A	N/A	N/A	24	24	24	24	N/A	N/A	N/A
SPD	12	12	12	12	12	12	12	12	12	12	12	12	12	12	12	12

NOTE: N/A = OPTION NOT AVAILABLE

*Min. Box Size, corresponding to 9" of Unit Space.

Compression Lugs

Style	Amp Rating	Breaker Type	Compression Connectors	Box Height Addition - Inches (mm)
MLO	125	N/A	(1)#6 - 350 kcmil Al/Cu	6 (152)
	250	N/A	(1)#6 - 350 kcmil Al/Cu	6 (152)
	400	N/A	(1) 400 - 600 kcmil Cu or (2)#6 - 350 kcmil Al/Cu	6 (152)
	600	N/A	(2)#6 - 350 kcmil Cu or Cu/Al or 400 - 600 kcmil Al/Cu	6 (152)
Main Breaker	100	ED4, ED6, HED4, CED6 ^①	(1)#14-2/0 AWG Cu or Al	Box must go to 24" wide on CED6 breaker only Add 6" to box height for NØ
	225	QR2, QRH2, HQR2, HQR2H	(1)#6 AWG - 350 kcmil Cu or Al	Box must go to 24" wide
	250	FXD6, HFD6, CFD6	(1)#6 AWG - 350 kcmil Cu or Al	Box must go to 24" wide for all breakers Requires an additional 6.0" box height
	400	JD6, JXD6, HJD6, CJD6, SJD6, SHJD6, SCJD6	(2)#1/0 AWG - 500 kcmil Cu or Al	9 (229)
	600	LD6, LXD6, HLD6, CJD6, SLD6, SHLD6, SCLD6	(2)#2/0 AWG - 500 kcmil Cu or Al	6 (152)

Alternate Lugs

Style	Amp Rating	Breaker Type	Standard AL Connectors	Box Height Addition - Inches (mm)
MLO	400	N/A	(1) 250 - 750 kcmil or (2)#3/0 AWG - 250 kcmil Cu or Al	6 (152)
Main Breaker	400	JD6, JXD6, HJD6, CJD6, SJD6, SHJD6, SCJD6	(1)#4/0 AWG - 750 kcmil Cu or Al	6 (152)

① Not available for feed thru lug.

Panelboards

Embedded Micro Metering Module™ (Type P2 Panelboard)

Selection

SEM3 System configured in Panelboards

The Siemens SEM3 system can be configured for factory installation in branch circuit monitoring applications. This option can lower the installation time of the system for the installer while providing a factory warranted solution.

The SEM3 system can be factory installed in unit space in type P2 & S5 Siemens panel boards and in Siemens switchboards. Please note P1 and P3 configurations are not available at this time and the amount of unit space needed varies depending upon the application. Please note that lead time adders will apply and may vary depending upon the configuration of the system.

SEM3 for use in Siemens Panelboards

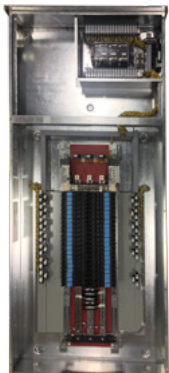

Type P2: Enclosure

- Available in a Type 1 rated enclosure.
- Minimum width & depth: 30" width x 7.75" depth
- Height: Up to 74" depending on branch breaker selection
 - Addition of monitoring on some mains (primary and subfeed) may require additional box length. In these cases the box will be increased to the next size available as a standard design. The option of monitoring on mains is not available for equipment rated for service entrance.
 - In cases where enclosure size is increased all multi-section panels will be increased to match the largest section.



Controller

SEM3 controller is mounted in a separate enclosure (relay cabinet) opposite of the feed location (i.e., bottom mount for top feed) with a height of 24". Each controller will be powered by direct tap connection to the panel section or through a 150VA potential transformer for systems above 480V. The direct tap connection will use 2 circuits from the distribution section (i.e., 42 circuits panel will have 40 circuits usable for distribution). Each controller can monitor up to 45 circuits. Applications that require monitoring more than 45 circuits will require additional P2 panel complete with SEM3.



Current Transformers (CTs)

Five sizes of CTs are available for use in the P2 panel: 50, 125, 250, 400 & 600 amp. All CTs are pre-mounted to a support bracket that attaches to the base rail of the interior of the panel board. Each bracket supports a maximum of 3 CTs and is designed for the breaker selected (brackets are not interchangeable between breaker frames). Each CT will be attached to a data module that is placed in the meter racks.



Meter Racks

All meter racks will be installed next to the SEM3 controller in the relay cabinet.

NOTE: Monitoring of 45 circuits will require: two 21 position racks and one 3 position rack

Panelboards

Embedded Micro Metering Module™ (Type P2 Panelboard)

Selection

P2 Devices
Enclosure sizes

Example P2 Panel with SEM3 Type 1 Enclosure (36" Wide x 7.75" Deep)

Enclosure heights are in 6" increments from 26" thru 74".
Enclosure heights: 26", 32", 38", 44", 50", 56", 62", 68", 74"

Example below is largest standard P2 enclosure for factory assembled panel with all small (1") branch breakers installed.

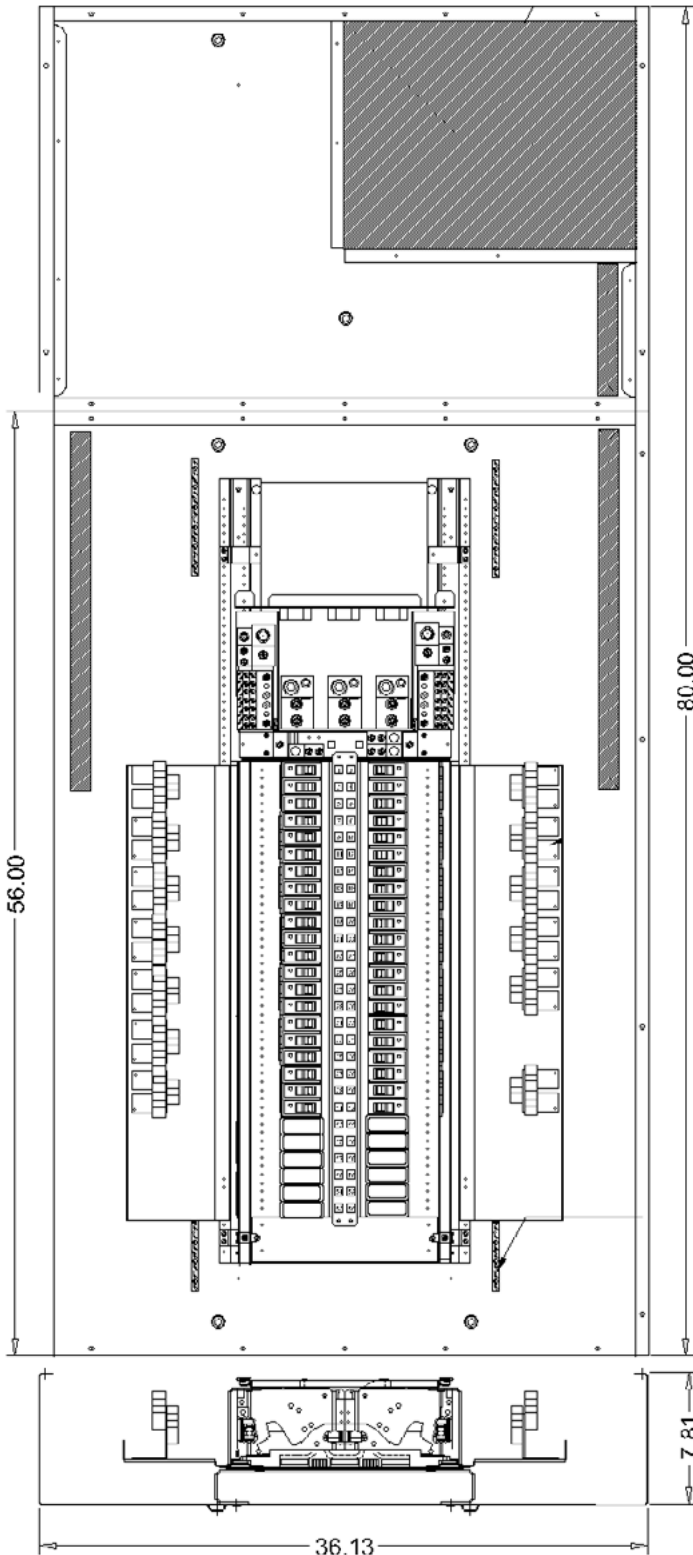

← 36" std. width →

Relay Cabinet which includes SEM3 components:
Meter rack
3 Phase PT 150VA
Controller:
- 21 circuits monitored: one controller and one 21-pos rack
- 42 circuits monitored: one controller and two 21-pos racks
- 45 circuits monitored: one controller and two 21-pos racks plus one 3-pos rack

Main Breaker / Main Lug space varies based on selected options

Unit space varies based on selected options

Note: All circuits do not have to be monitored by SEM3 - user can select any circuits in this space to be monitored.

Based on smallest branch breakers and a 3-phase main being monitored. There is a maximum of 42 circuits that can be monitored with the configuration shown. Some selections of main breakers and other subfeed options could limit this further.

In this situation there is 27" of unit space available - so 54 branch circuits could be monitored. If monitoring the main three additional circuits could be monitored with a total of 57 circuits.

This requires two controllers and three 21 position racks using 15" of unit space. - see below -

Note: If subfeed space is needed - it will take away from available unit space.

Panelboards

Type P2 Panelboard Connector Modifications

Selection

Enclosure Modifications

Description
Wider enclosure - 24" wide
Type 1 with gasket
Type 1 with dripshield
Type 2 enclosures
Type 3R enclosures
Type 3R/12 enclosures

Type 4 – Water Tight, Dust Tight, Steel Enclosure® (Actual NEMA-4 enclosure is larger than standard Type 1 enclosure. See chart below for reference to approximate actual size.)

Standard Box Height (in inches)	Actual NEMA 4 Enclosure Size®		
	H	W	D
32	32	20	8
38	42	30	8
44	48	36	8
56	60	36	10

NOTE: Larger Type 4 enclosures are not available.

Type 4X – Water Tight, Dust Tight and Corrosion Resistant® (consult plant for actual enclosure size)

Catalogue Number	Enclosure – Stainless Steel Size (inches) (304SS is standard)		
	H	W	D
B4X26	26	20	5.75
B4X32	32	20	5.75
B4X38	38	20	5.75
B4X44	44	20	5.75
B4X50	50	20	5.75
B4X56	56	20	5.75
B4X62	62	20	5.75
B4X68	68	20	5.75
B4X74	74	20	5.75

NOTE: 316SS is available as an option - must be specified.

- ① 16 Gauge Cans w/ 14 Gauge Front)
- ② 14 Gauge only
- ③ 14 Gauge only - 304SS Std, 316SS Optional)

Gauge Steel of Boxes/Fronts, Surface and Flush

Dimensions in Inches (mm)		Gauge Steel		
Width	Height	Box	Front/Door	Type
20 (508)	26-74 (660-1880)	14	14 ^③	Type 1
20 (508)	26-74 (660-1880)	16 ^②	16/14 ^②	Type 3R/12
20-36 (508-914)	32-60 (813-1524)	14 ^③	14 ^③	Type 4
20 (508)	26-74 (660-1879)	14 ^④	14 ^④	Type 4X

- ④ 15 Gauge Steel Can with 14 Gauge Door or Similar Approved Construction
- ⑤ No Optional Gauge available
- ⑥ 304SS 14 Gauge Std., 316SS 14 Gauge optional
- ⑦ Sizes do not match Standard Enclosure Sizes - See Table P1-21 - material is non-metallic - No Gauge Specified.

Panelboards

Type P2 Panelboard Kits and Accessories

Selection

Standard Enclosures

Box Height Inches	Catalogue Number				
	Type 1 Standard Trim			Type 3R	Type 3R/12 ①
	Box	Surface	Flush		
26	B26	S26B	F26B	NR26	WP26
32	B32	S32B	F32B	NR32	WP32
38	B38	S38B	F38B	NR38	WP38
44	B44	S44B	F44B	NR44	WP44
50	B50	S50B	F50B	NR50	WP50
56	B56	S56B	F56B	NR56	WP56
62	B62	S62B	F62B	NR62	WP62
68	B68	S68B	F68B	NR68	WP68
74	B74	S74B	F74B	NR74	WP74

① Same as Type 3R with Gasket added for Type 12 Spec.

Options For Type 1 Trims

Items must be ordered as manual line item on Spartanburg

Hinged trim – Replace “B” suffix with “H”

Door-in-door – Replace “B” suffix with “D”

Screw to Box - Replace “B” suffix with “C”

Metal card holder - Add “M” suffix on all trims

Option For 24" Wide Enclosures with Equal Gutter on Both Sides (Excludes Type 3R)

24" wide with equal gutter on both sides - Add “24” as prefix

Panelboards

Type P2 Panelboards

Dimensions

Type 1 Box

Box is symmetrical

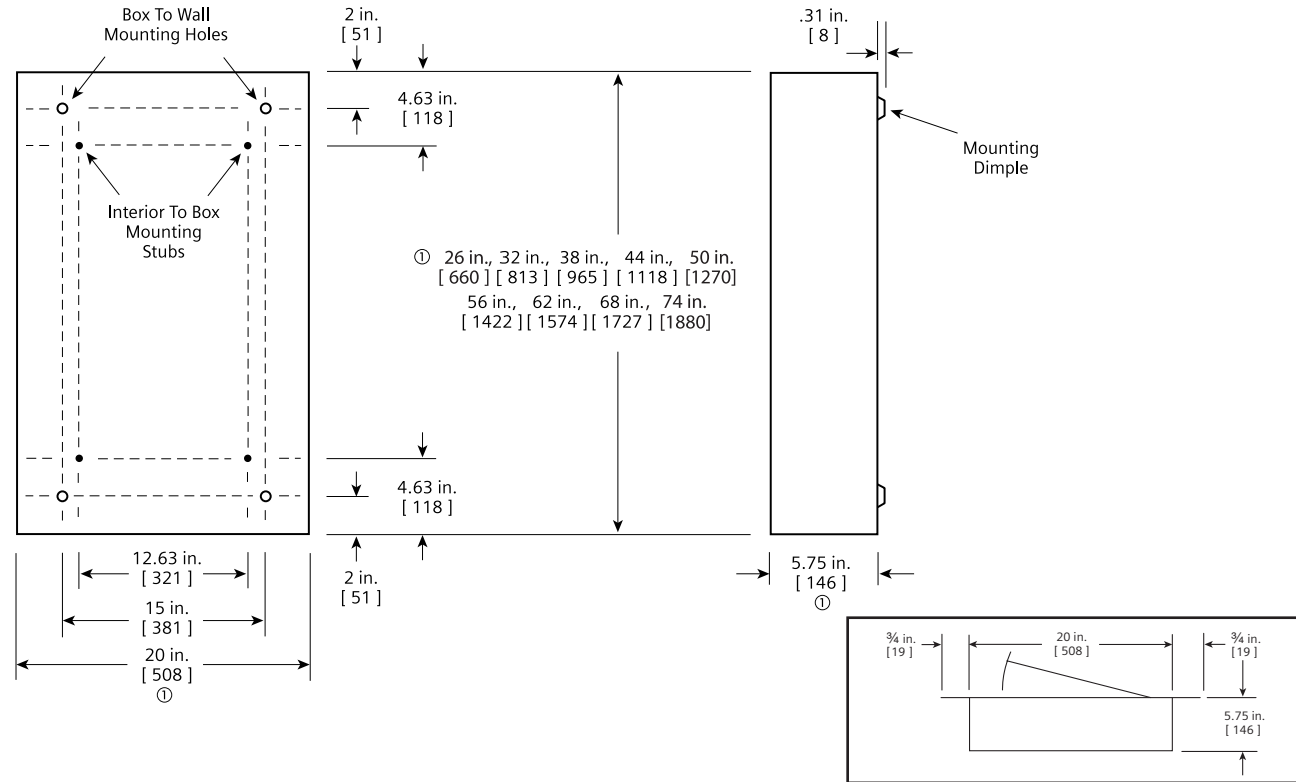

Flush Mounting

Type 3R and 3R/12 Box

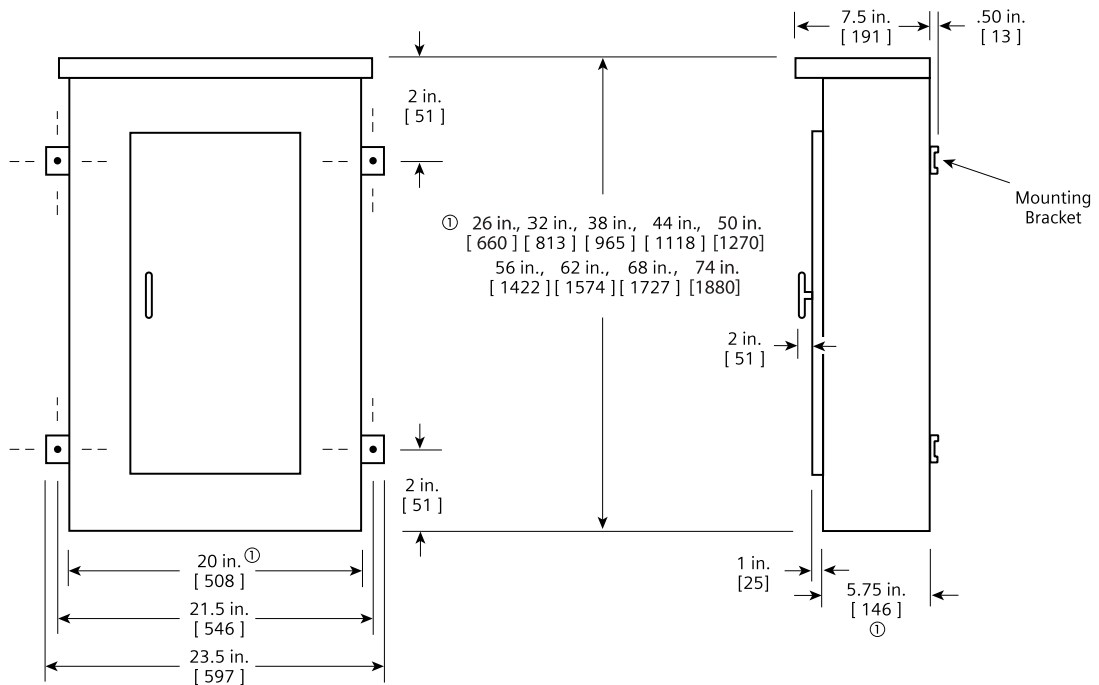

⓪ Dimensions are interior of the box. Add 5/8" to width for absolute dimension. Add 1/8" to height for absolute dimension.

Dimensions shown in inches and millimeters [].

Panelboards

Type P3 Panelboards

General

Features

Another innovation from Siemens is the P3 panel. It is a smaller, footprint distribution panel to fit a large number of applications that require more (or larger) branch devices than the lighting panel class offer. This panel offers a wide array of factory-assembled options, and has the ability to mix breaker frames in unit space up to 250 amps. Bussing options for the P3 vary from the standard aluminum to copper designs. All bussing in the P3 panel is tin-plated as a standard. Silver-plated copper is offered as an option on a copper bus. Subfeed lugs (up to 400 amp) are just a few of the options of this unique panel.

The P3 panel configurations, defined by the unit space, allow for a given amperage, main device, and box height. The P3 panel starts with a 56" high box. Breaker unit space can be mixed and matched to meet customer requirements. All 1" pole breakers (BL, BQD, ED, xGB frames) are mounted in 3" or 6" pole increments. Breaker frames, above 125 amps, are mounted in 6" single or twin breaker mountings. As an example panel, FD 250 amp and JD 400 amp breakers are mounted as subfeed breakers outside of unit space. Like other distribution panels, the P3 panel can have blank space added into the panel to allow for future expansions or modifications. Any expansions or modifications must be in 3" increments. BL, BQD and ED frame breakers have 3" or 6-pole kits and can be mixed in unit space by these increments. Breakers of the same frame can cross from one mounting to another if contiguous. xGB frame breakers cannot be mixed with other frame types. Any expansion or modification must be in 3" increments also. QR frame breakers are mounted in 6" increments for two and three pole single and twin mounted units. Changes in the unit space length for BL, BQD, xGB, or ED frame breakers require an additional deadfront center strip kit. Check with sales or the factory for additional unit space kits.

Main Lug/Main Breaker

Enclosure – Standard Type 1 enclosure is 24" wide x 7.75" deep. X Box Height is determined by main device and unit space. See charts for box height.

Voltage – 600V AC max.
250V DC max.

Amperage – 800 amp max.

Short Circuit Rating –
200,000 A @ 480 Vac

100,000 A @ 600 Vac IR max.
symmetrical or equal to the lowest rated device installed unless a series rating is indicated. Panels with subfeed or feed-thru lugs without a main device, circuit breaker or fusible unit, are limited to a three-cycle rating. The three-cycle rating for the P3 panel is limited to 22 Kaic. Note that the main device may be mounted remote from the panel.

Bussing – The P3 panel has more options to meet market requirements. The standard bussing is aluminum. The rating is per the requirements of CSA C22.2 No.29 – the standard for panelboards. All aluminum bussing is tin-plated. Optional bussing for the P3 panel is copper. The copper bus option for this panel is tin-plated.

Weight – Approximate

Total panelboard weight when filled with a normal quantity of breakers and accessories is about 5 lbs. (1 kg) per inch (54g per mm) of box height.

Gauge Steel of Boxes Fronts, Surface & Flush

Dimensions in inches (mm)		Gauge Steel	
Width	Height	Box	Front
24" (610)	56 - 80" (1422, 2032)	#14	#14

Panelboards

Type P3 Panelboards

Selection/Dimensions

Panel Unit Space To Box Height Requirements

"B" Dimension Box Height	P3 Panels With Standard Line Lugs. Unit Space (starting with 9" and adding 6" increments) "A" Dimension				
	Main Lugs			Main Breakers	
	400A	600A	800A	400A JD	600A LD
56	21	21	21	9	9
62	27	27	27	15	15
68	33	33	33	21	21
74	39	39	39	27	27
80	45	45	45	33	33

Main Lug Wire Bending

Panel Amps	Standard Connectors	C	D
400	(2) #3/0 AWG - 250 kcmil or (1) 600 kcmil	16.00	17.88
600	(2) #3/0 AWG - 500 kcmil	16.00	17.88
800	(2) 600 kcmil	16.00	17.88

Main Breaker Wire Bending - Inches (mm)

Panel Amps	C	E	F
JD	—	15.63 (397)	29.38 (746)
LD	—	14.75 (375)	29.38 (746)

Ⓢ This lug is removable.

Main Breaker Wire Bending Diagram

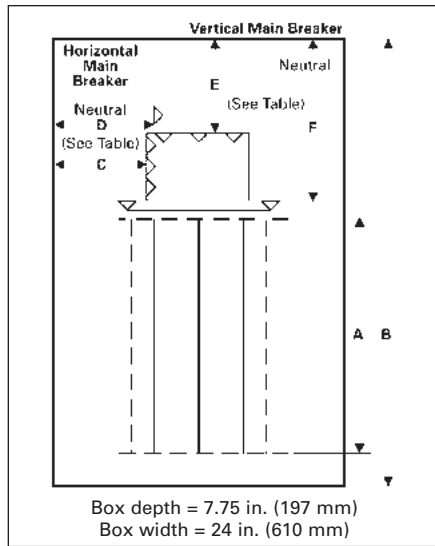

Main Breaker Wire Bending

Main Lug Wire Bending Diagram

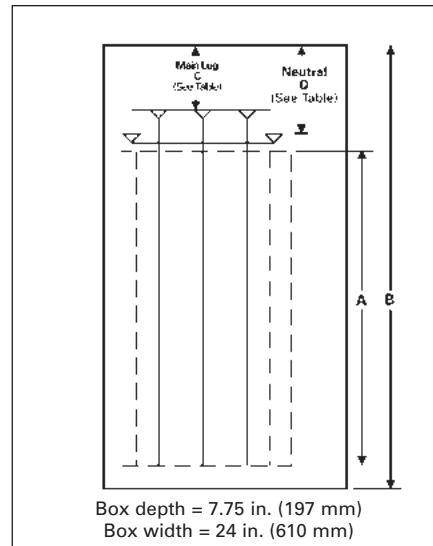

Main Lug Wire Bending

Branch Breaker Side Gutters Inches (mm)

Reference Letter	Panel Width 24" (609)
A	7.750 (197)
B	7.125 (181)
C	6.000 (152)
D [Ⓢ]	7.000 (178)
E	5.000 (127)
F	6.625 (168)

Ⓢ Single branch mounting construction.

Branch Breaker Wire Bending Diagram

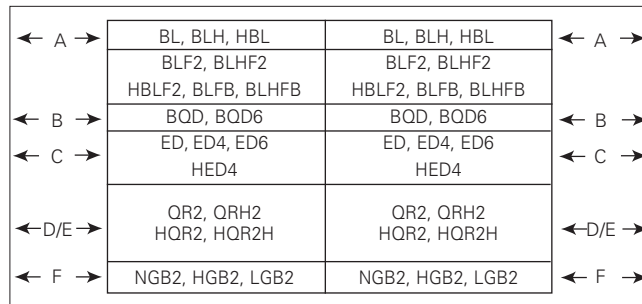

Branch Breaker Side Gutters

Panelboards

Type P3 Panelboards

Selection

Alternate Main Breakers

Ampere Rating	Breaker Type	Maximum Interrupting Rating (kA)			Ref. Catalogue Number	Available Configurations ^②			Available Trip Values
		240V	480V	600V		240V AC	480V AC	600V AC	
400	JXD6 ^①	65	35	25	JX	STD	STD	STD	200, 225, 250, 300, 350, 400
	JD6 ^①	65	35	25	J6	STD	STD	STD	200, 225, 250, 300, 350, 400
	HJXD6 ^①	100	65	35	H6	ADD	ADD	ADD	200, 225, 250, 300, 350, 400
	HJD6 ^①	100	65	35	H5	ADD	ADD	ADD	200, 225, 250, 300, 350, 400
	SJD6 ^①	65	35	25	SJ	ADD	ADD	ADD	200, 300, 400
	SHJD6 ^①	100	65	35	S2	ADD	ADD	ADD	200, 300, 400
600	LXD6 ^①	65	35	25	LX	STD	STD	STD	450, 500, 600
	LD6 ^①	65	35	25	L6	STD	STD	STD	250, 300, 350, 400, 450, 500, 600
	HLXD6 ^①	100	65	35	HL	ADD	ADD	ADD	250, 300, 350, 400, 450, 500, 600
	HLD6 ^①	100	65	35	HO	ADD	ADD	ADD	250, 300, 350, 400, 450, 500, 600
	SLD6 ^①	65	35	25	SL	ADD	ADD	ADD	300, 400, 500, 600
	SHLD6 ^①	100	65	35	S6	ADD	ADD	ADD	300, 400, 500, 600

① Vertically mounted

② STD = Standard configuration. ADD = Additional cost.

Panelboards

Type P3 Panelboards

Selection

Branch Circuit Breakers

Max. Amp Rating	Bolt-On Breaker Type	Amps	Provisions for Maximum Interrupting Rating (kA)							
			120V AC	120/240V AC	240V AC	277V AC	480V AC	600V AC	250V DC	
70	BQD6	15-70	—	65	65	—	—	—	10	14
100	BL	15-60	10	—	—	—	—	—	—	—
		70	—	10	—	—	—	—	—	—
		80-100	—	—	10	—	—	—	—	—
	BLH	15-60	—	—	22	—	—	—	—	—
		70	—	—	22	—	—	—	—	—
		80-100	—	—	—	22	—	—	—	—
	HBL	15-55	—	—	65	—	—	—	—	—
		60-100	—	—	—	65	—	—	—	—
	BLR (240V)	15-60	—	—	—	10	—	—	—	—
		70-100	—	—	—	10	—	—	—	—
	BLE (GFCI)	15-30	10	—	—	—	—	—	—	—
		40-60	—	10	—	—	—	—	—	—
	BLEH (GFCI)	15-30	22	—	—	—	—	—	—	—
15-60		—	22	—	—	—	—	—	—	
BLF (GFCI)	15-30	10	—	—	—	—	—	—	—	
	40-60	—	10	—	—	—	—	—	—	
BLHF (GFCI)	15-30	22	—	—	—	—	—	—	—	
	40-60	—	22	—	—	—	—	—	—	
HBLF2 (GFCI)	15-30	65	—	—	—	—	—	—	—	
	15-20	10	—	—	—	—	—	—	—	
BAF BAFH	15-20	22	—	—	—	—	—	—	—	
	15-20	—	22	—	—	—	—	—	—	
BQD	15-60	—	—	65	—	—	14	—	14	
	70-100	—	—	—	65	—	14	—	14	
125	NGB2	15-125	100	100	100	25	25	14	14 [ⓐ]	
		15-125	100	100	100	35	35	22	14 [ⓐ]	
		15-125	100	100	100	65	65	25	14 [ⓐ]	
	ED4	15-60	65	—	—	22	—	—	—	
		70-100	—	—	65	—	18	—	30	
		110-125	—	—	65	—	18	—	—	
	ED6	15-60	—	—	65	—	25	18	30	
		70-100	—	—	65	—	25	18	—	
		110-125	100	—	—	—	—	—	—	
	HED4	15-60	100	—	—	—	—	—	—	
70-100		—	—	—	65	—	—	—		
110-125		—	—	—	65	—	—	—		
225	QR2	100-225	—	—	10	—	—	—	—	
	QRH2	100-225	—	—	25	—	—	—	—	
	HQR2	100-225	—	—	65	—	—	—	—	
	HQR2H	100-225	—	—	100	—	—	—	—	

Subfeed Breakers (available in 2-pole or 3-pole)

Breaker Type	Mounting Position When Used as Subfeed Breaker	Ampere Ratings For Load	Maximum Interrupting Rating (kA) Symmetrical		
			240V AC	480V AC	600V AC
FD6 [ⓐ] , FXD6	Vertical	70-250	65	35	18
HFD6 [ⓐ] , HFXD6	Twin	70-250	100	65	25
JD6 [ⓐ] , JXD6	Single	200-400	65	35	25
HJD6 [ⓐ] , HJXD6	Single	200-400	100	65	35

Neutral Connectors

Wire Range	Max. Number of Connections	Max. Amps
#14-#1/0	44	125
#4 - 350 kcmil	6	250
(1)#4 - 600 kcmil or (2)#6 - 250 kcmil	1	400

NOTE: QR Breakers are twin mounted in unit space and take 6" of unit space. Limited to (6) per panel max. BL, HBL, BLH and BQD breakers are mounted in common mountings in 3" or 4) pole increments. ED2, ED4, ED6 and HED4 breakers are mounted in common mountings in 3" or (6) pole increments.

ⓐ Twin mounted subfeed breakers are mounted at bottom of panelboard only and adds 24" to the panel height.
 ⓑ Subfeed breaker is mounted at bottom of panelboard only. 400 amp subfeed breaker adds 30" to the panel height.

ⓐ 2-pole only (or) two outer poles of 3-pole breaker.

Panelboards

Type P3 Panelboard Modifications and Additions

Selection

Enclosures

Extra Gutter to Sides or Ends of the Can (Type 1 Only)

Description
6" end gutter 2" side gutter Barrier in gutter (add to extra gutter price – min 4" required)
Hinged trims Piano hinged trims Door-in-door trims Screw to the box trims
Trim mounted devices <ul style="list-style-type: none"> • Pilot lights • Toggle switches • Push buttons
Painted boxes Custom colours Increase gauge trims and boxes Stainless steel trims, Type 1

Meters

(Contact sales for pricing and application engineering for space requirements)

Panel Skirts

See page 10-64

Panel Bus Modifications

Represented by "A", "C" or "E" in the 11th digit of the catalogue number

Standard bussing is tin plated Al, alternate bus bar material can be selected: <ul style="list-style-type: none"> ▪ Tin plated copper ▪ Silver plated copper - optional

Subfeed and Feed-Thru (for 2-pole or 3-pole)

Ampere Rating	Connector Cu/Al Wire Range	Unit Space (inches)
---------------	----------------------------	---------------------

Subfeed (Double) Lugs for Main Lug Panelboards Only

225/250	(2) – #6 AWG-350 kcmil	6
400	(2) – 250 kcmil (1) – 600 kcmil	6

Feed-Thru Lugs – Cannot Be Used in Conjunction with SPD or Subfeed Breakers

See page <?> for unit space adders and compatibility with other options.

225/250	(1) – #6 AWG-350 kcmil	6
400	(2) – 250 kcmil (1) – 600 kcmil	6
600	(2) – 250-500 kcmil	9
800	(2) – 600 kcmil	12

Branch and Main Breaker Accessories

See page 10-44 and Breaker Section <ul style="list-style-type: none"> • Handle blocks • Handle locks • Aux. Contacts[Ⓞ] • UVR[Ⓞ]
--

Increase capacity neutral up to 200%

Main Bus Amps
125
250
400
600

See page 10-44 for unit space adders and compatibility with other options.

Copper MLO Only

Main Bus Amps
125
250
400
600

(Devices mounted and wired to the trim should also have hinged trim specified)

Surge Protection Device

See Section 10

Service Entrance Label

Type P3 Panelboards are factory labeled "SUITABLE FOR USE AS SERVICE ENTRANCE EQUIPMENT" when identified as "Service Entrance" at the time of order entry. For regulations governing this feature, please consult CEC, CSA or local electrical authorities.

P3 service entrance panels are available in type 1 enclosure only (indoor application) and come standard with plated copper.

Grounding of Panelboards

Ground Bars are shipped with the panel interior factory mounted.

- Non-Insulated Equipment Ground Bar
- Copper Non-Insulated Ground Bar
- Al Insulated Equipment Ground Bar
- Cu Insulated Equipment Ground Bar

Shunt Trip on Main or Branch

BL, BLH, HBL, BQD, ED4, HED4, ED6, HED6, QR2, QRH2, HQR2, HQR2H as branch only. BL, BLH, HBL, NGB2, HGB2, LGB2, ED2, ED4, HED4, ED6, uses 1" unit space for shunt trip. All others may be used on mains or subfeeds.

Ⓞ Accessories on 1" pole breakers (BL, BQD, ED) will take unit space.

Panelboards

Type P3 Panelboard Standard Modifications

Selection

Option Combinations

Amps	Incoming	Subfeed Lugs	Feed-thru Lugs	FDa Subfeed	JD ^① Subfeed	FD ^② Subfeed	200% Neutral	Min. Box Size (in.)	Unit Space (in)	
400 ^{②③}	Main Lug Only	•	—	—	—	—	•	56	21	
		—	•	—	—	—	•	56	15	
		—	—	•	—	—	•	56	9	
		—	—	—	•	—	•	56	9	
		—	—	—	—	•	•	62	9	
	Main Breaker (JD)	None Std.	—	—	—	—	—	•	56	9
			—	•	—	—	—	•	62	9
			—	—	•	—	—	•	68	9
			—	—	—	•	—	•	68	9
			—	—	—	—	•	•	74	9
600 ^{②③}	Main Lug Only	—	—	—	—	—	•	56	21	
		—	•	—	—	—	•	56	15	
		—	—	•	—	—	•	56	9	
		—	—	—	•	—	—	56	9	
		—	—	—	—	•	•	62	9	
	Main Breaker LD	—	—	—	—	—	—	•	56	9
			—	•	—	—	—	•	62	9
			—	—	•	—	—	•	68	9
			—	—	—	•	—	—	68	9
			—	—	—	—	•	•	74	9
800 ^{②③}	Main Lug Only	—	—	—	—	—	•	56	21	
		—	•	—	—	—	•	56	9	
		—	—	•	—	—	•	56	9	
		—	—	—	•	—	—	56	9	
		—	—	—	—	•	•	62	9	

① Subfed lugs are currently not offered as standard with main circuit breakers.

② Subfed lugs on panels above 400A are not standard.

③ 200% neutral cannot be provided along with a 400A subfeed breaker because the breaker blocks the 4th lug site.

Panelboards

Type P3 Panelboard Modifications and Additions

Selection

Compression Lugs

Style	Amp Rating	Breaker Type	Compression Connectors	Box Height Addition
MLO	400	N/A	(1) 250 - 500 kcmil or (2)# 1/0 AWG - 250 kcmil	—
	600	N/A	(2)#3/0 AWG - 500 kcmil	—
	800	N/A	(2) 400-750 kcmil Cu only	—
Main Breaker	400	JD6, JXD6, HJD6, SJD6, SHJD6	(2)#1/0 AWG - 500 kcmil Cu or Al	—
	600	LD6, LXD6, HLD6, SLD6, SHLD6	(2)#2/0 AWG - 500 kcmil Cu or Al	—

Alternate Lugs

Style	Amp Rating	Breaker Type	Standard AL Connectors	Box Height Addition
MLO	400	N/A	(1) 250 - 750 kcmil or (2)#3/0 AWG - 250 kcmil Cu or Al	6
	800	N/A	(3) 500 kcmil	6
	800	N/A	(4) 1/0-750 kcmil Cu or Al	6
Main Breaker	400	JD6, JXD6, HJD6, SJD6, SHJD6	(1)#4/0 AWG - 750 kcmil Cu or Al	6

Enclosure Modifications

24" Panel Width Description
Type 3R enclosures
Type 3R/12 enclosures ^①
Gasket between trim and box (Type 1)

Type 4X For Type P3^③

Water Tight, Dust Tight and Corrosion Resistant

(consult plant for actual enclosure size and for Type 4^② enclosures)

Box Height Inches	Enclosure – Stainless Steel		
	H	W	D
56	56	24	7.75
62	62	24	7.75
68	68	24	7.75
74	74	24	7.75
80	80	24	7.75

① 16 Gauge Cans w/ 14 Gauge Front)

② 14 Gauge only

③ 14 Gauge only - 304SS Std, 316SS Optional)

Panelboards

Type P3 Panelboard Kits and Accessories

Selection

Standard Enclosures

Box Height (in.)	Catalog Number				
	Type 1 Standard Trim			Type 3R	Type 3R/12
	Box	Surface	Flush		
56	24WD56	P3S56	P3F56	24NRD56	24WPD56
62	24WD62	P3S62	P3F62	24NRD62	24WPD62
68	24WD68	P3S68	P3F68	24NRD68	24WPD68
74	24WD74	P3S74	P3F74	24NRD74	24WPD74
80	24WD80	P3S80	P3F80	24NRD80	24WPD80

Options For Type 1 Trims

Items must be ordered as manual line item on factory

Hinged trim – Add "H" suffix

Door-in-door – Add "D" suffix

Metal card holder - Add "M" suffix

Provision for padlock - Add "-PL" suffix

Service entrance application - Add "SE" suffix

Breaker Kits and Accessories

Kit Number	Description	Contents
BBKGB32 (P2/P3)	NGB2, HGB2, LGB2 3" branch breaker kit	Kit contains top barrier, (3) A/C connectors, (1) B connector, hardware
BBKB32 (P2/P3)	BL/BQD 6-pole 3" branch breaker kit	Kit contains top barrier, (3) A/C connectors, (1) B connector, hardware
BBKNB32 (P2/P3)	NGB, 6-pole 3" branch breaker kit	Kit contains top barrier, (3) A/C connectors, (1) B connector, hardware
BBKEB32 (P3)	HEB 6-pole 3" branch breaker kit	Kit contains top barrier, (3) A/C connectors, (1) B connector, hardware
BBKED32 (P2/P3)	ED 6-pole 3" branch breaker kit	Kit contains breaker support, inter-phase barriers, (3) A/C connectors, (1) B connector, hardware
BBKQR2 [Ⓞ]	P3 twin BKR mounting kit for 1-phase/3-phase.	Kit contains all connectors and cover plates necessary to mount both 2 and 3-pole breakers
DFK1	BL, BQD, ED deadfront kit for 1" pole breakers	Center strips 3", 6", 9", 15", 21" plus mounting hardware
DFFP3	Deadfront filler 3"	3" empty space filler and hardware
DFFP6	Deadfront filler 6"	6" empty space filler and hardware
P3BK1	P3 bonding kit	Bonding strap and hardware
EBF1	HEB/NEB Filler Plate	Filler Plate
BBKQRP2FK	P3 Filler for QR. Dual mount horizontal. 1-phase/3-phase.	Kit contains all cover plates necessary to change from QJ to QR both 2 and 3-pole breakers. For 1-phase panel, both breakers must change from QJ to QR, cannot have one of each installed.

[Ⓞ] Although QR is rated 250A, it is limited to 225A in panelboard.

Type P3 Panelboards

Miscellaneous Parts and Accessories

Catalogue Number	Description
EGK	Al Ground Bus 44 Connections
BK1	Bonding kit for 250A max. and all P1 panels
IMK1	Interior Adjusting Kit
9271-1	Directory Card Holder
NBK3	1 Numbering Button Kit "Snap-in" type 1 @ 42
NBK4	1 Numbering Button Kit "Snap-in" type 43 @ 84
NBK5	1 Numbering Button Kit "Snap-in" type 85 @ 126
NBK6	1 Numbering Button Kit "Snap-in" type 127 @ 168.
NBK7	1 Numbering Button Kit "Snap-in" type 169 @ 210.
NBK8	1 Numbering Button Kit "Snap-in" type 211 @ 252.
ECGK	Cu Ground Bus 44 Connections
IGK	Insulated Al Ground Bus
ICGK	Insulated Cu Ground Bus
EWK2	End Wall Kit with Knockouts (24" W x 7.75" D)
DFFP1A	1" Filler Plate (Suitable for replacing QF3 in P1 thru S5 Panelboards and Switchboards)
P3BK1	P3 Bonding Kit
JCK24	24 trim screws and 24 trim clips
DFK1	BL, BQD, ED deadfront kit for 1" (include 7 different length centre strips)
12-1110-01	1 Directory card for 1-42 circuits
MCHK	1 Metallic directory card holder
FPLK2	2 Spare Fas-latch trim locks with 2 keys
DSK724	1 Dripshield 24"W x 7.75"D

Panelboards

Type P3 Panelboards

Dimensions

Type 1 Box

Box is symmetrical

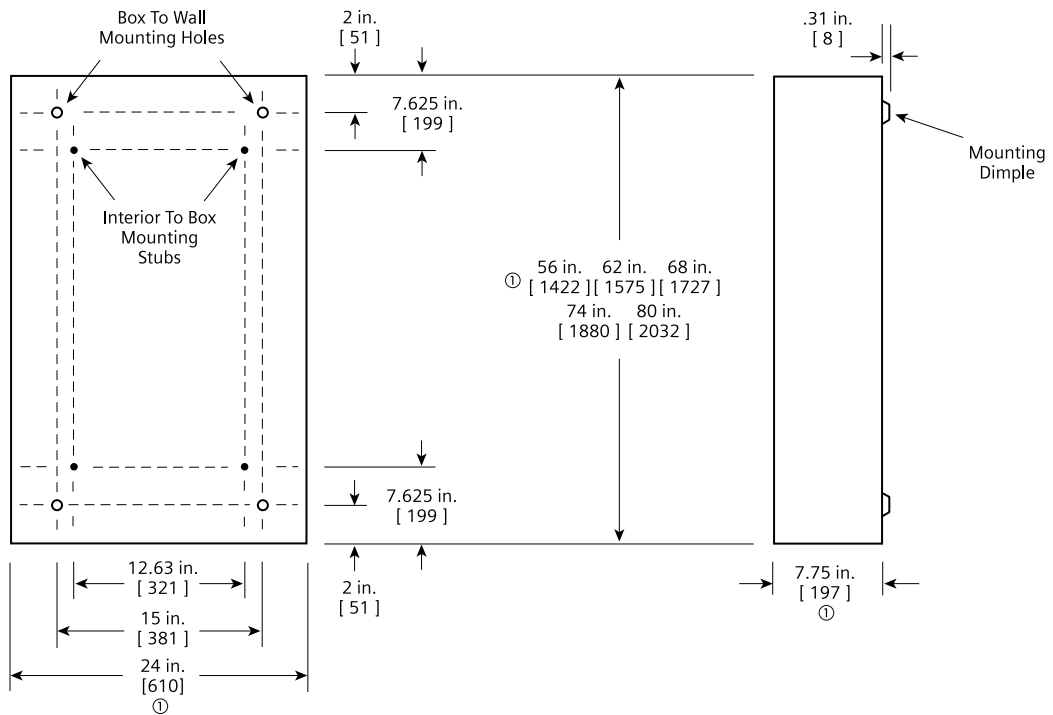

Type 3R and 3R/12 Box

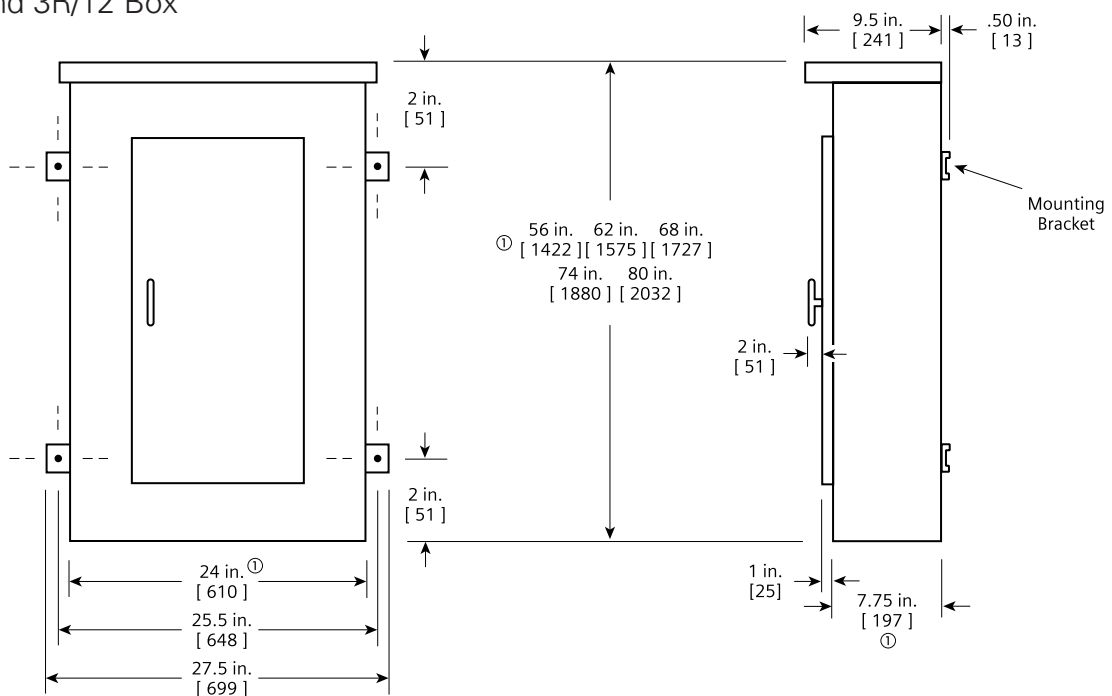

① Dimensions are interior of the box. Add 5/8" to width for absolute dimension. Add 1/8" to height for absolute dimension.
Dimensions shown in inches and millimeters [].

Panelboards

Distribution Connector Kits (Circuit Breakers)

Reference

Max Amp Rating	Breaker Family	Branch Breaker Type	Revised P1	P2	P3	S5	F2
100	General	BL, BLH, HBL, BQD6	No kit required	BBKB32	BBKB32	6BL2C ^③	—
125	General	NGB	No kit required ^①	BBKNB32	BBKNB32	SNBD	—
	General	NGB2, HGB2, LGB2	—	BBKGB32	BBKGB32	SGB2DCAN	—
	General	HEB	—	—	BBKEB32	SEBD	—
	Sentron	ED2, ED4, ED6, HED4	—	BBKED32	BBKED32	6E62 ^{②③}	—
	Sentron	CED6	—	BBKCED32	—	6CLE2 ^②	—
150	VL	NDG, LDG	—	—	—	SDGD	—
	3VA	3VA61	—	—	—	S3VA52TDCAN ^⑤	—
225	General Purpose	QR2, QR2H, HQR2, HQR2H	—	BBKQR1	BBKQR2	6QR2CAN ^④	—
250	Sentron	FXD6, FD6, HFD6, HHFD6	—	—	—	6F62 ^②	—
	VL	NFG, LFG	—	—	—	SFGD	—
	Sentron	CFD6	—	—	—	6CLF1C	—
	3VA	3VA52, 3VA62	—	—	—	S3VA52TDCAN ^⑤	—
400	Sentron	JXD6, JD6, HJD6, HHJD6	—	—	—	6JJ62 ^②	—
	VL (Single)	NJG, LJG	—	—	—	SJG1D	—
	VL (Twin)	NJG, LJG	—	—	—	SJG2D	—
	Sentron	CJD6	—	—	—	6CLJ1C	—
600	Sentron	LXD6, LD6, HLD6, HHLD6, SLD6, SHLD6, SJD6, SHJD6	—	—	—	6LL61C	—
	Sentron	CLD6	—	—	—	6CLL1C	—
	Sentron	SCJD6, SCLD6	—	—	—	6SCL61C	—
800	Sentron	MXD6, MD6, HMD6, CMD6, SHMD6, SCMD6	—	—	—	6M61C	—
1200	Sentron	NXD6, ND6, HND6, CND6, SHND6, SCND6	—	—	—	6N61C	—

① NGB branch breakers can be installed in P1 interior ending with suffix "-NGB" only.

② These are aluminum connectors. If copper is required please add suffix C.

③ 3.75" plate accommodates six 1-pole breakers.

④ For QR filler plate only, use p/n: **6QR2FKCAN**. For copper QR kit, use p/n: **6QR2CCAN**.

⑤ To field install a single **3VA52**, **3VA61** or **3VA62** breaker to an existing strap, provision kit p/n: **S3VA52PRCAN** is required.

Panelboards

Miscellaneous accessories

Selection

Spare Parts Kits

Kit Number	Current Product						Old Product is no longer Manufactured, some kits are available			QTY/ Kit	Product Description Note: Some kits apply to only specific enclosures used or configurations of the product listed
	P1 Revised	P2	P3	C1	C2	P1 Original	S1, S2, SE				
Strap Kits											
BBKB32		X	X						1	P2/P3 BL/BOD 100A max. Branch Strap kit Cu/Tin, uses 3 of unit space for 6 circuits total. Kit contains top barrier, (3) A/C connectors, (1) B connector, hardware.	
BBKB32AT		X	X						1	P2/P3 BL/BOD 100A max. Branch Strap kit Al/Tin, uses 3 of unit space for 6 circuits total. Kit contains top barrier, (3) A/C connectors, (1) B connector, hardware.	
BBKB32CS		X	X						1	P2/P3 BL/BOD 100A max. Branch Strap kit Cu/Silver, uses 3 of unit space for 6 circuits total. Kit contains top barrier, (3) A/C connectors, (1) B connector, hardware.	
BBKCED32		X							1	CED branch breacker kit Cu/Tin. Kit contains connector kit for P2 400A, 24 wide only	
BBKCED32CS		X							1	CED branch breacker kit Cu/Silver. Kit contains connector kit for P2 400A, 24 wide only	
BBKVA4P2P3		X	X						1	P2/P3 3VA41/xGB 125A max. Twin Mount Strap Kit, uses 3 of unit space for 6 circuits.	
BBKVA5262P2S		X	X						1	P2/P3 3VA52/61/62 , 250A max. Horizontal Mount Includes parts for both 1-ph and 3-ph. (includes Kit #BBKVA5262P2P3HW) Fits in 6" of unit space.	
BBKVA5262P2HW		X	X						1	Hardware kit for Branch/Main Horizontal or for Verical Mount 3VA52/61/62 in either P2 or P3 panels includes nut keepers. Generally needed for replacement parts	
BBKVA52P3T			X						1	Twin-mount strap kit for 3VA52 / in P3 devices. Requires 6 inches of unit space and allows for 6 circuits in total per kit. Two or three-pole breakers only.	
BBKVA52P3HW			X						1	Hardware kit for mounting one 3VA52 / in a P3 device nose-to-nose. This is in case of loss or for replacement purposes. Includes screws, retainers.	
BBKQR1		X							1	P2 QR 225A max. Single Mount Branch Strap Kit, 6 of unit space for one 2-p or 3-p breaker	
BBKQR2			X						1	P3 twin BKR mounting kit for 1-phase/3-phase. Kit contains all connectors and cover plates necessary to mount both 2 and 3-pole breakers	
BBKED32		X	X						1	P2/P3 ED Twin Mount Branch Strap Kit Cu/Tin, uses 3 of unit space for 6 circuits. Kit contains breaker support, inter-phase barrier, (3) A/C connectors, (1) B connector, hardware	
BBKED32AT		X							1	P2/P3 ED Twin Mount Branch Strap Kit Al/Tin, uses 3 of unit space for 6 circuits. Kit contains breaker support, inter-phase barrier, (3) A/C connectors, (1) B connector, hardware	
BBKED32CS		X							1	P2/P3 ED Twin Mount Branch Strap Kit Cu/Silver, uses 3 of unit space for 6 circuits. Kit contains breaker support, inter-phase barrier, (3) A/C connectors, (1) B connector, hardware	
BBKNB32		X	X						1	P2/P3 xGB Twin Mount Branch Strap Kit, 3 of unit space for 6 circuits. Kit contains top barrier, (3) A/C connectors, (1) B connector, hardware	
BBKGB32		X	X						1	P2/P3 GB2 Twin Mount Branch Strap Kit, 3 of unit space for 6 circuits. Kit contains top barrier, (3) A/C connectors, (1) B connector, hardware	
BBKEB32			X						1	HEB 6-pole 3 branch breaker kit, Kit contains top barrier, (3) A/C connectors, (1) B connector, hardware	
BBKQ1 (QJ is not avail. Use QR)		X							1	P2 QJ Sgl Mnt Branch Strap Kit, 6 of unit space for one 2-p or 3-p brkr	
Deadfront Parts											
NBK01A	X						X		1	Number Strips 1-60. Stick-on type; Use w/ P1 series Panels – includes 1/2 spacing numbers for BT twins. Replaces NBK03	
NBK02A	X						X		1	Number Strips 61-120. Stick-on type; Use w/ P1 series Panels – includes 1/2 spacing numbers for BT twins. Replaces NBK04-05	
NBK03A	X						X		1	Number Strips 121-240. Stick-on type; Use w/ P1 series Panels – includes 1/2 spacing numbers for BT twins. Replaces NBK06-08	
NBK3		X	X	X	X				1	Number Strips 1-42 (snap-in type, P2/P3 panels)	
NBK4		X	X	X	X				1	Number Strips 43-84 (snap-in type, P2/P3 panels)	
NBK5		X	X	X	X				1	Number Strips 85-126 (snap-in type, P2/P3 panels)	
NBK6		X	X	X	X				1	Number Strips 86-168 (snap-in type, P2/P3 panels)	
NBK7		X	X	X	X				1	Number Strips 169-210 (snap-in type, P2/P3 panels)	
NBK8		X	X	X	X				1	Number Strips 211-252 (snap-in type, P2/P3 panels)	
P1DFS250AFT	X								1	P1 250A Deadfront Support - for Feed-thru interiors only (4 per interior) Part # 11-D-3323-01 (replaces # 11-D-3212-01)	
P1DFS250ANFT	X								1	P1 250A Deadfront Support - for Non Feed-thru interiors only (4 per interior) Part # 11-D-3323-02 (replaces # 11-D-3212-02)	
P1DFS400A	X								1	P1 400A Deadfront Support (new for 3VA) - for both FT and NFT interiors. (#11-D-3315-01 replaces # 11-D-3004-01) (4 per interior)	
DFK1		X	X						1	BL, BOD, ED, xGB, xGB2, 3VA41 deadfront center strip kit for 1 pole breakers with mounting hardware. Center strips included (7 sizes) 3, 6, 9, 12, 15, 18, 21 (of branch height)	
DFK1.**		X	X						1	P2/P3 Deadfront center plate - available in 3 increments (starting with 3 and up to a max. of 57) ** represents the deadfront center length in inches.	
DFFP3		X	X						1	Deadfront filler, 3 steel blank filler plate (one each P2&P3) P2 Blank Deadfront Plate 3 / P3 Blank Cover Plate 2.97	
DFFP6		X	X						1	Deadfront filler, 6 steel blank filler plate (one each P2&P3) P2 Blank Deadfront Plate 6 / P3 Blank Cover Plate 5.97	
Filler Plates											
DFFP1A	X	X	X	X	X	X	X	X	1	DFFP1A Blank filler , 1 inch snap-in, replaced old QF3 and DFFP1 in Systems Products. Ref. old #12-1800-01 and 11-D-4554-01	
DFFP01B	X			X			X		1	P1 Main or Subfeed 250A Blank Filler Plate (use for Original or Revised P1 - also replaces DFFP01A/11-D-4560-01/12-A-1801-01) (Installs Vertical for 400A Main w/small DF opening)	
DFFP01C	X								1	P1 Main 400A Blank Filler Plate (use for Revised P1 400A with Large MB opening only)	
DFFPVA41A	X								1	RP1 Main/Sub-feed, 3VA4/BL/BOD/ED/xGB filler (replaces DFFPED01CAN / 12-A-1802-01)	
DFFPED01CAN	X						X		5	P1 Main Filler 100-125A frames ED, BL/BOD or xGB (old filler used for Original or Revised P1 and other applications)	
DFFPFD01CAN	X						X		5	FD Main Filler Plate for 1-Ph and 3-Ph P1 Panels (use for Original or Revised P1 and other applications)(P2/P3 and S1/S2/SE)	
DFFPJD01CAN	X						X		5	JD Main Filler Plate for 1-Ph and 3-Ph P1 Panels – Small MB opening (use for Original or Revised P1 & other applications)(P2/P3 & S1/S2)	
DFFPJD02	X						X		1	JD Main Filler Plate for 1-Ph and 3-Ph – for P1 Panels with Large MB Opening only.	
DFFPQJ01CAN	X						X		5	QJ Main Filler Plate for 3-Phase (3-pole) P1 Panels (use for Original or Revised P1 and other applications)	
DFFPQJ02CAN	X						X		5	QJ Main Filler Plate for 1-Phase (2-pole) P1 Panels (use for Original or Revised P1 and other applications)	

Panelboards

Miscellaneous accessories

Selection

Spare Parts Kits (cont.)

Kit Number	Current Product						Old Product is no longer Manufactured, some kits are available			QTY/ Kit	Product Description Note: Some kits apply to only specific enclosures used or configurations of the product listed
	P1 Revised	P2	P3	C1	C2	P1 Original	S1, S2, SE				
Filler Plates (cont.)											
MBKQRFK	X					X			1	P1/Revised P1 Filler for 1PH/3PH QR. Horizontal Mount only.	
BBKQRP1FK		X							1	P2 Filler for QR. Horiz. or vert. mount. Contains all cover plates necessary to change from QJ to QR both 2 and 3-pole breakers.	
BBKQRP2FK			X						1	P3 Filler for QR. Dual mount horiz. Kit contains all cover plates necessary to change from QJ to QR both 2 and 3-pole breakers. For 1-phase panel, both breakers must change from QJ to QR, cannot have one of each installed.	
EBF1			X						1	EB Filler Plate	
DFP3AP01CAN			X						5	Used for filling space in a P3 dead-front when a BL, BQD, ED, xGB or 3VA41 branch breaker is installed. Can be replaced in field if lost or damaged.	
Locks, Hadnles, & Keys											
LPKEY01ACAN	X	X	X	X	X	X			4	Key for FAS-Latch lock Siemens FAS-Latch and other various fronts use this standard key #B363A	
LPKEY01BCAN	X	X	X	X	X	X			25	Key for FAS-Latch lock Siemens FAS-Latch and other various fronts use this standard key #B363A	
FPLK2	X	X	X	X	X	X			1	FAS-Latch lock with 2 keys, 14-16 gauge door - for Lighting Panel Type 1 front Replacement lock for use when door thickness is 14-16 gauge painted steel	
LPLOCK02ACAN	X	X	X	X	X	X			5	Siemens FAS-Latch Replacement Lock Kit with two B363A Keys, for 12 Gauge Steel, Lighting Panel Type 1 Fronts, various styles.	
LPLOCK03ACAN	X	X	X	X	X	X			5	Siemens FAS-Latch Replacement Lock Kit with two B363A Keys, for 10 Gauge Steel, Lighting Panel Type 1 Fronts, various styles.	
K71-1804-01	X	X	X	X	X	X			1	T-Handle lock - for Lighting Panels Type 3R & 12 Replacement lock for use with any P1, P2, & P3 panels with Type 3R/12 enclosures.	
General Hardware											
JCK24	X	X	X	X	X	X			1	J-Type speed nut - lighting panel fronts - 24 pieces per pack Replacement J-nuts for use with lighting panel fronts and deadfronts.	
BNK2		X							1	P2 neutral 3-step lug - Tin-plated aluminum - 1 piece per pack with mounting hardware 14 connections for #6-1/0 wire and 12 connections for #14-#6 wire	
BNK350NCAN		X	X						10	Narrow 350 KCMLL lug - Tin-plated aluminum - 1 piece per pack with mounting hardware One #6-350KCMLL connection.	
LPP2NB01CAN		X							10	P2 Neutral 2-Step lug - Tin-plated aluminum - 1 piece per pack with mounting hardware Three connections for #6-1/0 wire and 18 connections for #14-#6 wire.	
ECGK	X	X	X			X			1	ECGK Copper Ground Bus Kit, Connection count: (6) of #14-1/0 and (15) of #14-6 Connections (21 Holes total). Some connections allow multiple wires.	
EGK	X	X	X			X			1	EGK Al/Cu Ground Bus Kit, Connection count: (6) of #14-1/0 and (15) of #14-6 Connections (21 Holes total). Some connections allow multiple wires.	
ICGK	X	X	X			X			1	ICGK Insulated Copper Ground Bus Kit, Connection count: (6) of #14-1/0 and (15) of #14-6 Connections (21 Holes total). Some connections allow multiple wires.	
IGK	X	X	X			X			1	IGK Insulated Al/Cu Ground Bus Kit, Connection count: (6) of #14-1/0 and (15) of #14-6 Connections (21 Holes total). Some connections allow multiple wires.	
IMK1	X	X	X			X			1	Interior Mounting Kit with Adjustment Provisions for P1/P2/P3	
LPDC01CAN	X	X	X	X	X	X	X		10	Panelboard Directory Card 9 x 4 - 8 pieces per pack Kit includes 8 cards. New cards have 1-42, 43-84, 85-126, and 127-168 circuits.	
LPDC01	X	X	X	X	X	X	X		10	Panelboard Directory Card. 5.5X5, for 1-90 circuits.	
LPDC02	X	X	X	X	X	X	X		10	Panelboard Directory Vinyl Pouch, 6.3x6.1.	
9271-1	X	X	X	X	X	X	X		10	Directory Card Holder for 9 x 4	
P1CONACPHCU	X								6	RP1 A/C-Phase Replacement Copper Connectors, Kit of 6 pcs plus mounting hardware. Also can be used to replaced AL A/C-Phase Connectors.	
P1CONBPHAL	X								6	RP1 B-Phase Replacement Aluminum Connectors, Kit of 6 pcs plus mounting hardware	
P1CONBPHCU	X								6	RP1 B-Phase Replacement Copper Connectors, Kit of 6 pcs plus mounting hardware	
P1SCRWS	X					X			42	P1 Branch breaker mounting screws - pack of 42 screws, part #11-A-1505-03, 10-32 x 0.312 Hex Washer Head Screw - Do Not Substitute	
MCHK	X	X	X	X	X	X	X		1	Metal Card Holder Kit - Field Installable	
SDKN	X	X				X			1	Dripshield kit for Standard Enclosure (20W x 5.75D)	
DSK724			X						1	Dripshield 24"W x 7.75"D	
Bonding Kits											
BK1A	X								1	Revised P1 Bonding Kit including Service Disconnect Label	
P2BK1		X							1	P2 250A Max Horiz. MB Bonding Strap Kit	
P2BK2		X							1	P2 125A max. Main Lug Bonding Strap Assembly	
P2BK3		X							1	P2 250-600A MLO and all Vert MB Bonding Kit	
P3BK1			X						1	P3 bonding kit 800A max MLO+MB	

Panelboards

B74FLR Enclosures & Related Bottom Covers

Quick & Easy Installation Features

This "universal fit" enclosure is capable of sitting on the floor or over the conduit, eliminating the need to extend conduit or cut knockouts. If installed correctly, there will be no need for a panel skirt.

This enclosure includes two bottom endwalls: a standard and a special endwall with a cutout. The standard endwall is mounted at the bottom as usual, and the special endwall is mounted above it with two screws. By removing the standard endwall and moving the special endwall to the lower position, the enclosure can be mounted around conduit stubbed up from the floor.*

Any size P1 or P2 interior from 26" to 74" can fit in this 20" wide enclosure with the proper lower cover installed. See chart below for part numbers (See back for details).

The bottom section of the enclosure left open by all fronts (except the 74" front) will require a special lower cover installation. These are available in both surface and flush variations in six-inch increments from 6" - 48" height, to match the front "void" sizes. The chart to the right shows which lower covers are available for the interior selected.

Contractor Labor Savings

When installed to code, the labor to cut knockouts and extend conduit to the bottom endwall is eliminated.

Instruction Sheets:

Enclosure: B74FLR Instructions
 Lower Cover: BXXCVR Instructions
 Endwall Kit: EWK3 Instructions

Enclosure Part Number: B74FLR

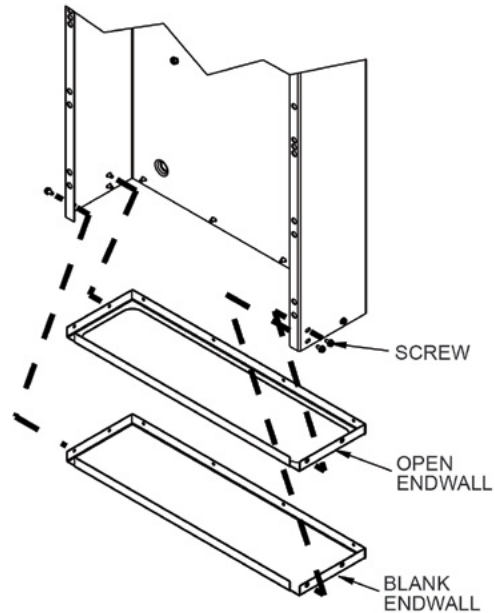

Standard Box Size	Standard Front Size	Required Lower Cover			
		Flush Mounted		Surface Mounted	
26" x 20"	26"	48"	BXXCVR48F	48"	BXXCVR48S
32" x 20"	32"	42"	BXXCVR42F	42"	BXXCVR42S
38" x 20"	38"	36"	BXXCVR36F	36"	BXXCVR36S
44" x 20"	44"	30"	BXXCVR30F	30"	BXXCVR30S
50" x 20"	50"	24"	BXXCVR24F	24"	BXXCVR24S
56" x 20"	56"	18"	BXXCVR18F	18"	BXXCVR18S
62" x 20"	62"	12"	BXXCVR12F	12"	BXXCVR12S
68" x 20"	68"	6"	BXXCVR06F	6"	BXXCVR06S
74" x 20"	74"	0"	None Required	0"	None Required

*Contractor is required to seal and install as required per local/national codes.

Panelboards

B74FLR Enclosures & Related Bottom Covers

The enclosure to the right shows two mounting studs at the top which are used for all sizes of P1/P2 panels that fit 20" wide x 5.75" deep enclosures. There are two studs at the bottom for mounting a 74" interior (Note: Interior sizes reference the standard enclosure size needed for the interior and front). The 74" can fits the 74" interior and front without any additional covers.

As interiors get shorter in six-inch increments, lower covers are needed to fill the space below the interior and standard front. Mounting holes and hardware are provided for attaching the bottom of the base rails.

Example: A 44" interior is 30" shorter than a 74" enclosure so it will need a 30" lower cover. Pick Surface or Flush to match the front.

Fronts available to use

- Standard FasLatch Front
- Screw-to-box front (standard & piano hinge)
- Hinge-to-box front (standard & piano hinge)
- Door-to-door front (standard & piano hinge)

Note: Although stainless steel piano hinge fronts are available, stainless steel lower covers are NOT available at this time.

Special endwall retrofit kit: EWK3

This kit includes the "open" endwall that can be used to replace a standard endwall in any 20" wide x 5.75" deep enclosure if needed for special mounting situations. Contractor is responsible to seal and secure per local/national codes.

Note: This B74FLR Enclosure is cULus Listed as a Electric Cabinet Box and when additional gutter space is available (beyond the required minimum Enclosure size required by the Panel Interior), this additional Gutter space is considered part of the Enclosure and does not require special wiring rules that apply to a "wire way". It is not a Panel Skirt, although in some cases it can be used in place of an Enclosure plus a panel skirt when installed per local and National codes.

Think of this as you would a "Switchboard Enclosure" resting on the floor, similar wiring rules should apply to the open bottom.

Enclosure Part Number: B74FLR

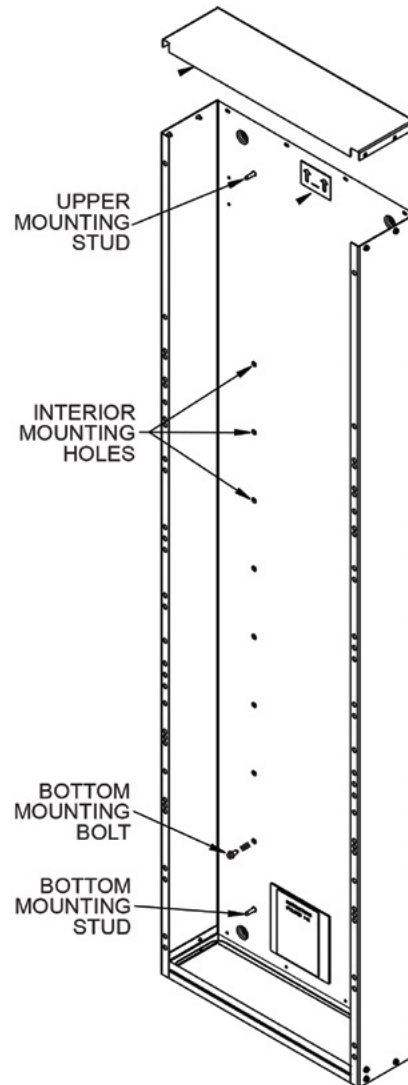

SEISMIC INSTALLATIONS ONLY		
ENCLOSURE TYPE	GRADE 5 HARDWARE (QTY)	TORQUE (LBS-FT)
1	1/2"-13 (4)	60
3R/12	3/8"-16 (3)	30

USE SIEMENS EQUIPMENT GROUND BUS TYPES ESK, IOK, ECK, ICK		Grid, bus location
Small Terminal	Large Terminal	
(1/2) Wires #14-#12 20 (in)	(1/2) Wires #14-#10 35 (in)	
(1) Wire #10 25 (in)	(1) Wire #8 40 (in)	
(1) Wire #8-#6 30 (in)	(1) Wire #6-#4 45 (in)	
	(1) Wire #3-#0 50 (in)	Type 1, 3R & 3R/12 Enclosure

Example of Label provided on each enclosure with UL/cULus marking

Panelboards

Accessories Enclosures

Selection

Miscellaneous parts and accessories-enclosures

Catalog Number	Description	Comments
EWK1	End Wall Kit with Knockouts (20"W x 5.75" DP)	Type 1 Only
EWK2	End Wall Kit with Knockouts (24"W x 7.75" DP)	Type 1 Only
EWK3	End Wall Kit - open center space - ref B74FLR (20" W x 5.75" DP)	Type 1 Only

EWK1 End Wall w/KOs (20"W X 5.75"D)

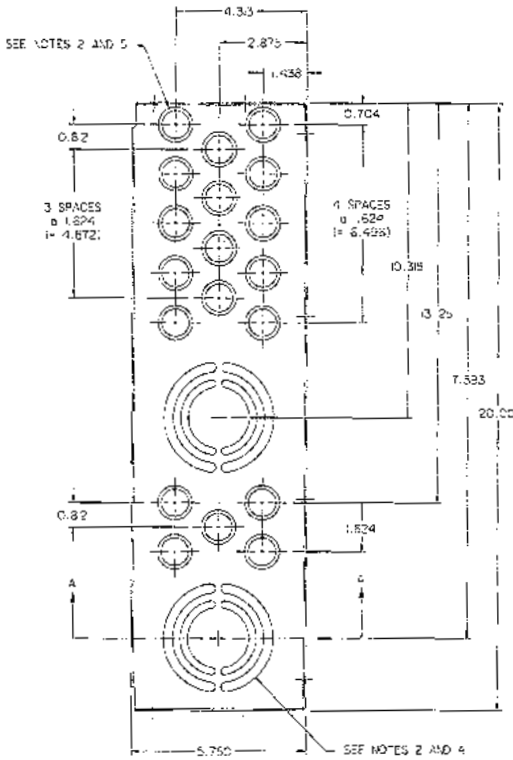

EWK2 End Wall w/KOs (20"W X 5.75"D)

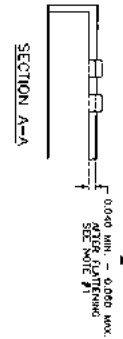
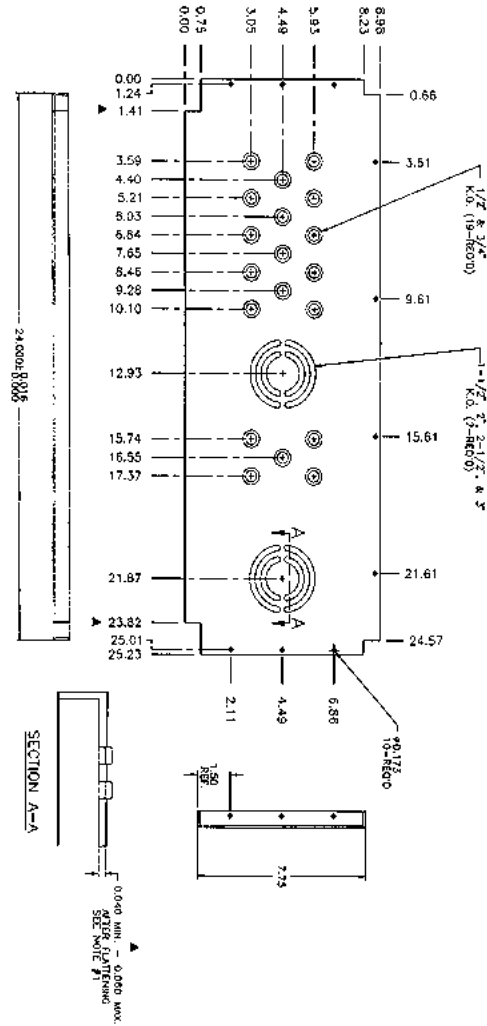

Panelboards

Lighting panel ground bus information: P1, P2, P3

Selection

Lighting panel ground bus information: P1-P2-P3

Catalog Number	Description	Comments
EGK	Al Ground Bus 44 Connections	Type 1, 3R, 3R/12
ECGK	Cu Ground Bus 44 Connections	Type 1, 3R, 3R/12
IGK	Insulated Al Ground Bus	Type 1, 3R, 3R/12
ICGK	Insulated Cu Ground Bus	Type 1, 3R, 3R/12

EGK / ECGK / IGK / ICGK Installation Instructions:

Ground bus to be mounted in either left or right gutter with hardware provided. Applied torque ratings shall be 45-lbs-inch for three No. 10 AWG solid copper conductors in the large holes. For all other combinations of conductors, refer to the torque rating label on the panelboard.

Note: For IGK / ICGK, insure ground bar is attached to Glastic insulator with two screws before mounting insulator to enclosure. Ground Bar mounts thru side holes oriented as shown on picture below.

Wire size range of the

EGK/ECGK/IGK/ICGK lug connections/holes:

(Note: The multiple combinations typically only apply when used as an equipment ground. If similar bar is used as a neutral bar, only one wire can be used in each hole.)

1. Connection count: (6) of #14-1/0 and (15) of #14-6 Connections (21 Holes total). (note: one Connection may be needed for incoming Ground Connection)
2. The Maximum wire size the standard ground accepts is:
1/0 in the Large Holes and #6 in the Smaller Holes.
3. Small Hole can accept:
(1-2 wires) #14-12; (1 wire) #10; (1 wire) #8-#6.
4. The Large Hole can accept:
(1-3 wires) #14-#10; (1 wire) #8; (1 wire) #6 - #4; (1 wire) #3-1/0.
5. Max. connections if largest wire size is used:
 $(6 \times 1) + (15 \times 1) = 21$
6. Max. connections if smallest wire size is used:
 $(6 \times 3) + (15 \times 2) = 48$
7. Request for Ground Lug greater than 1/0 in Size requires a Special Modification in COMPAS when Line Item is entered (specify number of connections needed greater than 1/0) or Manual Line for Custom Ground (specify number of connections needed greater than

This chart is on labels for P1, P2 and P3 enclosures.

USE SIEMENS EQUIPMENT GROUND BUS
TYPES EGK, IGK, ECGK, ICGK

Torque required to secure wire sizes listed below:

Small Terminal	Large Terminal
(1-2 Wires)-#14-#12 20 lb-in	(1-3 Wires)-#14-#10 35 lb-in
(1 Wire)-#10 20 lb-in	(1 Wire)-#8 40 lb-in
(1 Wire)-#8-#6 30 lb-in	(1 Wire)-#6-#16 45 lb-in
	(1 Wire)-#3-1/0 50 lb-in

Grd. bus location

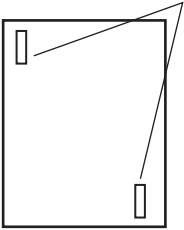

Type 1, 3R and 3R/12 Enclosure



Panelboards

Power and Distribution

Selection

Type S5 (SPP6)

**600 Volts AC, 250 Volts DC Maximum
1200 Ampere Mains**

**1200 Ampere Maximum Branch
UL & CSA Short Circuit Rating —
200,000A IR Maximum**

**Branch Breaker Symmetrical
Interrupting Capacity**

**Based on Underwriters' Test
Procedure**

Meets 1996 NEC wire bending
requirement, section 373-6.
CSA - C22.2 No. 0.12

Panelboards

Listed by Underwriters' Laboratories,
Inc., under "Panelboards" File #E2269
for interiors and #E4016 for boxes and
fronts. Meet Federal Specification
W-C375B/Gen. & CSA Certificate No.
1518681.

Service

600 Volts AC, 250 Volts DC, Maximum.
1 Phase, 3 Wire; 3 Phase, 3 Wire; or
or 3 Phase, 4 Wire.

Panelboard Fronts and Doors

Standard panelboards are furnished
with 4 piece trim with ventilation.
Fronts are fabricated from code gauge
steel and finished ASA61.

Main Breakers

All 400A and 1200A frame main break-
ers are mounted horizontally.

Main Lug Connectors

Ampere Rating	Connectors Range/Phase
225A - 400A	(1) #1/0-750MCM CU/AL or (2) #1/0-250MCM CU/AL
600A	(2) #1/0-750MCM CU/AL or (4) #1/0-250MCM CU/AL
800A	(3) #1/0-750MCM CU/AL or (6) #1/0-250MCM CU/AL
1200A	(4) #1/0-750MCM CU/AL or (8) #1/0-250MCM CU/AL

End Gutters

Ampere Rating	Main Lug (inches)	Main Breaker (inches)
400/600	15.967	13.0
800/1200	15.967	13.0

Boxes

38" wide, 12.75" deep (Type 1, 2)

38" wide, 14.25" deep (Type 3R/12)

Panelboard Specifications

Maximum Panel Ampere	Unit Space (MLO)	Box Height	120/240Volts 1 Phase, 3 Wire	120/208 Volts 3 Phase, 4 Wire	600 Volts 3 Phase, 3 Wire	347/600 Volts 3 Phase, 4 Wire
400A	30"	60"				
600A	45"	75"				
800A	60"	90"				
1200A	60"	90"				

Panelboards

Power and Distribution

Selection

Main Breaker Selection

Amperage Rating	Breaker Type	Trip Type	Maximum Interrupting Rating (kA)			Available Trip Values
			240V	480V	600V	
400	JXD6 JD6 HJD6 HHJD6 CJD6	Thermal Magnetic	65	35	25	200, 225, 250, 300, 350, 400
			65	35	25	200, 225, 250, 300, 350, 400
			100	65	35	200, 225, 250, 300, 350, 400
			200	100	50	200, 225, 250, 300, 350, 400
			200	150	100	200, 225, 250, 300, 350, 400
	SJD6 SHJD6 SCJD6	Electronic (Solid State)	65	35	25	200, 300, 400
			100	65	35	200, 300, 400
			200	150	100	200, 300, 400
600	LXD6 LD6 HLD6 HHL6 CLD6	Thermal Magnetic	65	35	25	450, 500, 600
			65	35	25	250, 300, 350, 400, 450, 500, 600
			100	65	35	250, 300, 350, 400, 450, 500, 600
			200	100	50	250, 300, 350, 400, 450, 500, 600
			200	150	100	450, 500, 600
	SLD6 SHLD6 SCLD6	Electronic (Solid State)	65	35	25	300, 400, 500, 600
			100	65	35	300, 400, 500, 600
			200	150	100	300, 400, 500, 600
800	MXD6 MD6 HMD6 CMD6	Thermal Magnetic	65	50	25	500, 600, 700, 800
			65	50	25	500, 600, 700, 800
			100	65	50	500, 600, 700, 800
			200	100	65	500, 600, 700, 800
	SMD6 SHMD6 SCMD6	Electronic (Solid State)	65	50	25	600, 700, 800
			100	65	50	600, 700, 800
			200	100	65	600, 700, 800
1200	NXD6 ND6 HND6 CND6	Thermal Magnetic	65	50	25	800, 900, 1000, 1200
			65	50	25	800, 900, 1000, 1200
			100	65	50	800, 900, 1000, 1200
			200	100	65	800, 900, 1000, 1200
	SND6 SHND6 SCND6	Electronic (Solid State)	65	50	25	800, 1000, 1200
			100	65	50	800, 1000, 1200
			200	100	65	800, 1000, 1200

Branch Breaker Side Gutter Inches (mm)

Reference Letter	Panel Width 38 Inches Dimensions in inches (mm)
A	14.00 (356)
B	13.98 (355)
C	11.62 (295)
D	10.00 (254)
E	7.61 (193)
F	8.75 (222)
G	8.25 (210)
J	11.76 (299)
K	7.92 (201)
M	13.42 (341)
N	12.00 (305)
P	14.25 (362)
Q	13.42 (341)

← A →	BL, BLH, HBL, BQD	BL, BLH, HBL, BQD	← A →
← B →	NGB2, HGB2, LGB2	NGB2, HGB2, LGB2	← B →
← D →	ED4, ED6, HED4, HHED6	ED4, ED6, HED4, HHED6	← D →
← E →	CED6	CED6	← E →
← F →	QR2, QRH2, HQR2, HQR2H	QR2, QRH2, HQR2, HQR2H	← F →
← G →	FD6, FXD6, HFD6, HHFD6	FD6, FXD6, HFD6, HHFD6	← G →
← AA →	3VA52 (MFAS, HFAS, CFAS)	3VA52 (MFAS, HFAS, CFAS)	← AA →
← AB →	3VA61 (MDAE, HDAE, CDAE, LDAE)	3VA61 (MDAE, HDAE, CDAE, LDAE)	← AB →
← AC →	3VA62 (MFAE, HFAE, CFAE, LFAE)	3VA62 (MFAE, HFAE, CFAE, LFAE)	← AC →
← J →	CFD		← J →
← K →	JD6, JXD6, HJD6, HHJD6	JD6, JXD6, HJD6, HHJD6	← K →
← M →	SJD6, SHJD6, LD6, LXD6, HLD6, HHL6, SLD6, SHLD6		← M →
← N →	CJD6, SCJD6, CLD6, SCLD6		← N →
← P →	MXD6, MD6, HMD6, CMD6, NXD6, ND6, HND6, CND6		← P →
← Q →	SMD6, SHMD6, SCMD6, SND6, SHND6, SCND6		← Q →

Panelboards

Power and Distribution

Selection

Branch Circuit Breaker Selection^①

Breaker Frame Rating	Trip Type	Breaker Type	Poles	Trip Amperage	Mounting Height Inches (mm)			Max IC Rating (kA)		
					Single	Twin	Gutter ^③	240V	480V	600V
100	Thermal Magnetic	BL	1, 2, 3	15, 20, 25, 30, 40, 50, 60, 70, 80, 90, 100	—	3.75 (95) ^{②③}	14 (356)	10	—	—
		BLH	1, 2, 3	15, 20, 25, 30, 40, 50, 60, 70, 80, 90, 100	—	3.75 (95) ^{②③}	14 (356)	22	—	—
		HBL	1, 2, 3	15, 20, 25, 30, 40, 50, 60, 70, 80, 90, 100	—	3.75 (95) ^{②③}	14 (356)	65	—	—
		BOD6 ^④	1, 2, 3	15, 20, 30, 40, 50, 60, 70	—	3.75 (95) ^{②③}	14 (356)	65	—	10
	Ground Fault Circuit Interrupter	BLE (GFCI)	1, 2	15, 20, 30, 40, 50, 60	—	3.75 (95) ^②	14 (356)	10	—	—
		BLF (GFCI)	1, 2	15, 20, 30, 40, 50, 60	—	3.75 (95) ^②	14 (356)	10	—	—
BLHF (GFCI)		1, 2	15, 20, 30, 40, 50, 60	—	3.75 (95) ^②	14 (356)	22	—	—	
Arc Fault Circuit Interrupter	BAF (AFCI)	1	15, 20	—	3.75 (95) ^②	14 (356)	10	—	—	
BAFH (AFCI)	1	15, 20	—	3.75 (95) ^②	14 (356)	22	—	—		
125	Thermal Magnetic	ED2	1, 2, 3	15, 20, 30, 40, 50, 60, 70, 80, 90, 100	3.75 (95) ^{②③}	3.75 (95) ^{②③}	10 (254)	10	—	—
		ED4	1, 2, 3	15, 20, 30, 35, 40, 50, 60, 70, 80, 90, 100, 110, 125	3.75 (95) ^{②③}	3.75 (95) ^{②③}	10 (254)	65	18	—
		ED6	1, 2, 3	15, 20, 30, 35, 40, 50, 60, 70, 80, 90, 100, 110, 125	3.75 (95) ^{②③}	3.75 (95) ^{②③}	10 (254)	100	18	18
		HED4	1, 2, 3	15, 20, 30, 35, 40, 50, 60, 70, 80, 90, 100, 110, 125	3.75 (95) ^{②③}	3.75 (95) ^{②③}	10 (254)	100	65	30
		CED6	2, 3	15, 20, 30, 35, 40, 50, 60, 70, 80, 90, 100, 110, 125	3.75 (95) ^③	3.75 (95) ^③	7.61 (193)	200	200	100
		NGB2	1, 2, 3	15, 20, 25, 30, 35, 40, 50, 60, 70, 80, 90, 100, 110, 125	3.75 (95) ^{②③}	3.75 (95) ^{②③}	13.98 (355)	100	25	14
		HGB2	1, 2, 3	15, 20, 25, 30, 35, 40, 50, 60, 70, 80, 90, 100, 110, 125	3.75 (95) ^{②③}	3.75 (95) ^{②③}	13.98 (355)	100	35	22
		LGB2	1, 2, 3	15, 20, 25, 30, 35, 40, 50, 60, 70, 80, 90, 100, 110, 125	3.75 (95) ^{②③}	3.75 (95) ^{②③}	13.98 (355)	100	65	25
		3VA41 (SEAB)	1, 2, 3	15, 20, 25, 30, 35, 40, 45, 50, 60, 70, 80, 90, 100, 110, 125	3.75 (95)	3.75 (95)	13.98 (355)	65	25	14
		3VA41 (MEAB)	1, 2, 3	15, 20, 25, 30, 35, 40, 45, 50, 60, 70, 80, 90, 100, 110, 125	3.75 (95)	3.75 (95)	13.98 (355)	85	35	18
		3VA41 (HEAB)	1, 2, 3	15, 20, 25, 30, 35, 40, 45, 50, 60, 70, 80, 90, 100, 110, 125	3.75 (95)	3.75 (95)	13.98 (355)	150	65	25
		150	Electronic (Solid State)	3VA61 (MDAE)	3	40, 100, 150	5 (127)	5 (127)	9.59 (244)	100
3VA61 (HDAE)	3			40, 100, 150	5 (127)	5 (127)	9.59 (244)	100	65	22
3VA61 (CDAE)	3			40, 100, 150	5 (127)	5 (127)	9.59 (244)	200	100	35
3VA61 (LDAE)	3			40, 100, 150	5 (127)	5 (127)	9.59 (244)	200	150	50
225	Thermal Magnetic	QR2	2, 3	100, 110, 125, 150, 175, 200, 225	5 (127)	5 (127)	8.75 (222)	10	—	—
		QRH2	2, 3	100, 110, 125, 150, 175, 200, 225	5 (127)	5 (127)	8.75 (222)	25	—	—
		HQR2	2, 3	100, 110, 125, 150, 175, 200, 225	5 (127)	5 (127)	8.75 (222)	65	—	—
		HQR2H	2, 3	100, 110, 125, 150, 175, 200, 225	5 (127)	5 (127)	8.75 (222)	100	—	—
250	Thermal Magnetic	FXD6, FD6	2, 3	70, 80, 90, 100, 110, 125, 150, 175, 200, 225, 250	5 (127)	5 (127)	8.25 (210)	65	35	22
		HFD6	2, 3	70, 80, 90, 100, 110, 125, 150, 175, 200, 225, 250	5 (127)	5 (127)	8.25 (210)	100	65	25
		CFD6	2, 3	70, 80, 90, 100, 110, 125, 150, 175, 200, 225, 250	—	5 (127)	11.76 (299)	200	200	100
		3VA52 (MFAS)	2, 3	40, 45, 50, 60, 70, 80, 90, 100, 110, 125, 150, 175, 200, 225, 250	5 (127)	5 (127)	10.10 (257)	85	35	18
		3VA52 (HFAS)	2, 3	40, 45, 50, 60, 70, 80, 90, 100, 110, 125, 150, 175, 200, 225, 250	5 (127)	5 (127)	10.10 (257)	100	65	25
		3VA52 (CFAS)	2, 3	40, 45, 50, 60, 70, 80, 90, 100, 110, 125, 150, 175, 200, 225, 250	5 (127)	5 (127)	10.10 (257)	200	100	35
	Electronic (Solid State)	3VA62 (MFAE)	3	100, 250	5 (127)	5 (127)	9.59 (244)	100	35	18
		3VA62 (HFAE)	3	100, 250	5 (127)	5 (127)	9.59 (244)	100	65	22
		3VA62 (CFAE)	3	100, 250	5 (127)	5 (127)	9.59 (244)	200	100	35
		3VA62 (LFAE)	3	100, 250	5 (127)	5 (127)	9.59 (244)	200	150	50
400	Thermal Magnetic	JXD6, JD6	2, 3	200, 225, 250, 300, 350, 400	8.75 (222)	8.75 (222)	7.92 (201)	65	35	25
		HJD6	2, 3	200, 225, 250, 300, 350, 400	8.75 (222)	8.75 (222)	7.92 (201)	100	65	35
		HHJD6	2, 3	200, 225, 250, 300, 350, 400	8.75 (222)	8.75 (222)	7.92 (201)	200	100	50
		CJD6	2, 3	200, 225, 250, 300, 350, 400	8.75 (222)	—	12 (305)	200	150	100
	Electronic (Solid State)	SJD6	3	200, 300, 400	8.75 (222)	—	13.42 (341)	65	35	25
		SHJD6	3	200, 300, 400	8.75 (222)	—	13.42 (341)	100	65	35
		SCJD6	3	200, 300, 400	8.75 (222)	—	12 (305)	200	150	100
		NJG	3	250, 400	6.25 (159)	6.25 (159)	8 (203)	65	35	25
LJG	3	250, 400	6.25 (159)	6.25 (159)	8 (203)	200	100	25		
600	Thermal Magnetic	LXD6	2, 3	450, 500, 600	8.75 (222)	—	13.42 (341)	65	35	25
		LD6	2, 3	250, 300, 350, 400, 450, 500, 600	8.75 (222)	—	13.42 (341)	65	35	25
		HLD6	2, 3	250, 300, 350, 400, 450, 500, 600	8.75 (222)	—	13.42 (341)	100	65	35
		HHLD6	2, 3	250, 300, 350, 400, 450, 500, 600	8.75 (222)	—	13.42 (341)	200	100	50
		CLD6	2, 3	450, 500, 600	8.75 (222)	—	12 (305)	200	150	100
	Electronic (Solid State)	SLD6	3	300, 400, 500, 600	8.75 (222)	—	13.42 (341)	65	35	25
SHLD6	3	300, 400, 500, 600	8.75 (222)	—	13.42 (341)	100	65	35		
SCLD6	3	300, 400, 500, 600	8.75 (222)	—	12 (305)	200	150	100		
800	Thermal Magnetic	MXD6	2, 3	500, 600, 700, 800	10 (254)	—	13 (330)	65	50	25
		MD6	2, 3	500, 600, 700, 800	10 (254)	—	13 (330)	65	50	25
		HMD6	2, 3	500, 600, 700, 800	10 (254)	—	13 (330)	100	65	50
		CMD6	2, 3	500, 600, 700, 800	10 (254)	—	13 (330)	200	100	65
	Electronic (Solid State)	SMD6	3	600, 700, 800	10 (254)	—	12 (305)	65	50	25
		SHMD6	3	600, 700, 800	10 (254)	—	12 (305)	100	65	50
		SCMD6	3	600, 700, 800	10 (254)	—	12 (305)	200	100	65
		—	—	—	—	—	—	—	—	—
1200	Thermal Magnetic	NXD6	2, 3	800, 900, 1000, 1200	10 (254)	—	13 (330)	65	50	25
		ND6	2, 3	800, 900, 1000, 1200	10 (254)	—	13 (330)	65	50	25
		HND6	2, 3	800, 900, 1000, 1200	10 (254)	—	13 (330)	100	65	50
		CND6	2, 3	800, 900, 1000, 1200	10 (254)	—	13 (330)	200	100	65
	Electronic (Solid State)	SND6	3	800, 1000, 1200	10 (254)	—	12 (305)	65	50	25
		SHND6	3	800, 1000, 1200	10 (254)	—	12 (305)	100	65	50
SCND6	3	800, 1000, 1200	10 (254)	—	12 (305)	200	100	65		

① Space includes housing frame plate with blank cover plate. Provision includes all necessary mounting hardware, less circuit breaker, and includes housing frame cover plate with breaker handle opening.

② 1 to 6 poles may be mounted in 3.75" (95) of unit space
 ③ Accessories such as shunt trips on three pole breakers require 6.25" (159) of unit space.
 ④ Also 10kA at 600Y/347 Volts.

⑤ Refer to Table 5 for layout dimensions.

Panelboards

Modifications and Additions

Selection

Type S5

When required, special constructions or additions to standard panelboards may be specified for all **factory-assembled** Power and Distribution Panelboards. Below and on the next page are listed many of those available for Type S5 panelboards. In no case do these apply to **Narrow** (Column) Width Lighting Panelboards or **Unassembled** Panelboards.

1. Miscellaneous

ENCLOSURE TYPE
Type 1
Type 2 (Drip-proof)
Type 3R
Type 12

2. Painted Finish

Touch-Up Paint (ASA61, Light Gray) 12 oz. aerosol can, Catalog Number TUP61

3. Miscellaneous Accessories

Nameplate — laminated, engraved Tamper-Resistant Screws
--

4. Devices Mounted on Gutter Cover — Includes Device, Mounting — Wired or Unwired

Toggle Switch — SPST or 3-way; 15A
Pilot Light — General Purpose, Neon or Incandescent
Pushbutton

5. Feed-Thru Lugs^① (One Set Per Panel)

Ampere Rating	Unit Space (Additional inches)		
	3-Pole	2-Pole	MLO
400			10
600	Consult Sales	Consult Sales	10
800			17.5
1200			17.5

6. MLO Compression Lugs —

Available as main lugs and neutral lug.

Ampere Rating	Aluminum (Specify Size)	Copper (Specify Size)	Deduct From Available Unit Space (inches)
400	Consult Sales Office	Consult Sales Office	5
600			5
800			5
1200			5

7. Grounding of Panelboards^②

Non-Insulated Equipment Ground Bus Including Ground Lug
Insulated Equipment Ground Bus Including Ground Lug

8. Remote Control Switches^{③④}

600V AC Ampere Rating	ASCO 920 Mechanically Held ^{⑤⑥}		Siemens CLH Electrically Held ^⑥	
	2-Pole	3-Pole	2-Pole	3-Pole
30	Unit space 20"		Unit space 20"	
60				
75				
100				
150 ^④				
200 ^④				
225				

9. Increased Capacity Neutral

Ampere Rating	Unit Space (inches)	
	Phase	Neutral
400	600	None
400	800	None
600	1200	None
800	1200	None

10. Circuit Breaker Accessories

Handle Blocking Device
Blocks handle in either the "ON" or "OFF" position. Available for:

Breaker Type	Cat. Number
BL, BLH, HBL, BQ, BQH, HBQ	ECQL1
All BQD, GB	BQDHBD
All QR	HPLQR
All BQD, NGB, NGB2, HGB2, LGB2	BQDPLD
All ED	E2HBL
All FD	FD6HB1
All JD, LD	JD6HBL
All MD, ND, PD	MN6BL
3VA52/61/62	3VA93780LB10

Padlocking Device — Padlocks in "OFF" position. Available for:

Breaker Type	Cat. Number
BQ, BQH, BL, BLH, HBL	ECQLD3
One Pole BL, BLF, BE, BAF	ECPLD1
Two-Pole BL, BLF, BE	ECPLD2
All QR	HPLQR
All BQD, NGB, NGB2, HGB2, LGB2	BQDPLD
All ED	ED2HPL
All FD	FD6PL1
All JD, LD	JD6HPL
All MD, ND, PD	MN6PLD
3VA41	3VA90380LB11
3VA52/61/62	3VA91380LB11

11. Ground Fault Sensing Relay Kit^⑩ Equipment Protection (30 mA)

For Use with Breaker Types	Number of Poles	Description
ED4, ED6, HED4	1, 2, 3	Basic kit Basic kit with bell alarm

12. Main Bus

Standard main bus and ground bus are tin plated aluminum. For copper main bus, neutral bus and ground bus change prefix 'A' to 'C' on catalog number and contact your sales office for pricing.

13. Copper Lugs — For Main Lug Only Panels

Standard main lugs and neutral lugs are tin plated aluminum, UL & CSA listed for use with aluminum/copper cables. For copper lugs in the mains and neutral for use with copper cables only, contact sales.

14. Shunt Trip on Main^{⑥⑦⑧⑨} and Branches

Description	Cat. Number
"BL, BQD6 (branch only) QR2, QRH2, QOR2, HQR2H, ED2, ED4, HED4 (branch only) All others through 1200A"	See breaker portion of this catalogue

15. Sentron TPS (TVSS Modules)

100kA, 150kA, 200kA, 250kA, 300kA Options Surge Counter Remote Indicator

16. Customer Metering

Siemens Digital Metering with Remote Display SEM3 Embedded Metering
--

① For use on main lug, main breaker or main switch panels without subfeed breakers.
② Ground bar not installed in box.
③ For short circuit ratings with remote control switches, consult sales office.
④ Available in 90" high enclosure only. Unit space is 42 1/2" with Test and Monitor Panel; 45" without Test and Monitor Panel.

⑤ Not available on Sensitrip IV.
⑥ For required unit space — consult local sales office.
⑦ Price does not include control power transformer.
⑧ Price 600 Volt 7 1/2" high units.
Mounting height increases to 6.25" when shunt trip is required.
⑨ Shunt Trip on 100A frame breakers increases mounting height to 6.25" for twin mounting.

⑩ Not CSA approved.

Panelboards

Modifications and Additions Replacements for Circuit Breakers

Selection

Replacement Connecting Strap Guide

The following table may be used to obtain the proper connector kit by measuring the exterior dimensions of the panel. Every attempt has been made to make this table complete and accurate. The table is based on panels produced by ITE, Bulldog and Siemens from 1958 to present. Should any questions arise please contact your Siemens sales office for replacements.

Panelboard				
Tub Width	Depth	Panel Type	Replacement Max Amps	Note
30" - 36" - 42"	9"	OLD CDP	400	MCCB only.
	9.75"	OLD CDP	600	MCCB only.
32" - 38"	13.75"	CDP/VB6	1200A	MCCB series 6 connectors
			600A	"VB" style units only (*)
38"	12.75"	SPP/FPP6	1200A	MCCB series 6 connectors
			600A	"VK" or "VB" style (*)

* If switch unit width is 17" it is a vacubreak. If switch unit width is 23" or 28" it is a "VK" switch.

Connecting Strap For Use With SPP/FPP, S5^③

Max Amp Rating	Breaker Family	Breaker Type	Catalogue Number	Unit Height	Mounting
100	General	BQ, BQH, HB BL, BLH, HBL, BQD6	6BL2C ^{②③}	3.75" (95)	Twin
125	General	NGB2, HGB2, LGB2	SGB2DCAN	3.75" (95)	Twin
	Sentron	ED2, ED4, ED6, HED4	6E62 ^{②③}	3.75" (95)	
		CED6	6CLE2 ^①	3.75" (95)	
	3VA	3VA41	S3VA41TDCAN	3.75" (95)	
			S3VA41TDHCAN ^⑥	7.50" (191)	Twin, High Density
150	3VA	3VA61	S3VA52TDCAN ^⑥	5" (127)	Twin
225	General Purpose	QR2, QR2H, HQR2, HQR2H	6QR2CAN ^④	5" (127)	Twin
	Sentron	FXD6, FD6, HFD6, HHFD6	6F62 ^②	5" (127)	
		VL	NFG, LFG	SFGD	
	Sentron	CFD6	6CLF1C	5" (127)	
	3VA	3VA52, 3VA62	S3VA52TDCAN ^⑥	5" (127)	Twin
400	Sentron	JXD6, JD6, HJD6, HHJD6	6JJ62 ^①	8.75" (222)	Twin
	Sentron	CJD6	6CLJ1C	8.75" (222)	Single
600	Sentron	LXD6, LD6, HLD6, HHLD6, SLD6, SHLD6, SJD6, SHJD6	6LL61C	8.75" (222)	Single
		CLD6	6CLL1C	8.75" (222)	
		SCJD6, SCLD6	6SCL61C	8.75" (222)	
800	Sentron	MXD6, MD6, HMD6, CMD6, SHMD6, SCMD6, SJD6, SHJD6, SCJD6, SCLD6	6M61C	10" (254)	Single
1200	Sentron	NXD6, ND6, HND6, CND6, SHND6, SCND6	6N61C	10" (254)	Single

3VA Breaker Provision Kits

Breaker Type	Cat. Number	Description
3VA52, 3VA61 or 3VA62 Breaker	S3VA52PRCAN	Contains the necessary hardware to land breaker on an existing scrap kit

① These are aluminum connectors. If copper is required please add suffix C.

② 3.75" (95) plate accommodates six 1-pole breakers.

③ Connecting strap kits include connecting straps, hardware, and cover plates for switchboards and power panels. Breakers to be ordered separately.

④ QR filler plate only, use p/n: 6QR2FKCAN.

For copper QR kit, use p/n: 6QR2CCAN.

⑤ To field install a single 3VA52, 3VA61 or 3VA62 breaker to an existing strap, provision kit p/n: S3VA52PRCAN is required.

⑥ High Density Kit, requires 7.50" Unit Space to fit QTY (6) 2 Pole breakers.

Blank Filler Plates (No Breaker Cutout)

For use with Series 6 CDP Panelboards, S5, F2, SMP, FCI and FCII Switchboards.	
Height	SPP/FPP/CDP/VB 6
1.25"	6FPB01
2.50"	6FPB02
3.75"	6FPB03
5.00"	6FPB05
10.00"	6FPB10
15.00"	6FPB15

Connecting Strap Kits and Front-Filler Plates^①

For use with NDP-CDP-7, S3

Breakers	Catalogue Number
BQD6 (S3 only)	7 BQD6-2
BL, BLH, HBL,	7 BL-2
ED2, ED4, ED6, HED4	7 E6-2
Filler 1 Pole	DFFP1A

Panelboards

Fusible/Power and Distribution

Selection

Type F2

**600 Volts AC, 250 Volts DC Maximum
600 Ampere Main Switch,
1200 Ampere Main Lugs Only
600 Ampere Maximum Branch
UL & CSA Short Circuit Rating –
200,000A IR Maximum**

Meets 1996 NEC wire bending requirement, section 373-6.
CSA - C22.2 No. 0.12

Panelboards

Listed by Underwriters' Laboratories, Inc., under "Panelboards" File #E2269 for interiors and #E4016 for boxes and fronts & CSA Certificate No. 1518681.

Service

600 Volts AC, 250 Volts DC, Maximum. 1 Phase, 3 Wire; 3 Phase, 3 Wire; or 3 Phase, 4 Wire.

Boxes

38" wide, 12.75" deep, Type 1

Panelboard Fronts and Doors

Standard panelboards are furnished with 4 piece trim. Fronts are fabricated from code gauge steel and finished ASA61.

Fuses

The Proper Fuse Type for the Application is Selected Using the Following Parameters:

- Voltage Requirements
- Conductor Ampacity
- Horsepower Requirements
- Maximum Available RMS Fault Current
- CSA Fuse Class

Main Switch Panel Connectors

Ampere Rating	Connectors Range/Phase
400A-600A	(1, 2) #3/0-500MCM CU or (1) #4/0-500MCM AL
800A	(1-3) #1/0-500MCM CU/AL
1200A	(1-3) #1/0-500MCM CU/AL

Branch Switch Connectors

Switch Ampere Rating	Wire and Cable Range
30	(1) - #14 - #2 AWG (Cu or Al)
60	(1) - #14 - #2 AWG (Cu or Al)
100	(1) - #14 - #1/0 AWG (Cu or Al)
200	(1) - #6 AWG - 350 kcmil (Cu or Al)
400	(1) - 750 kcmil OR (2) - 250 kcmil (Cu or Al)
600	(2) - 750 kcmil OR (4) - 250 kcmil (Cu or Al)

Main Lug Panels

Ampere Rating	Connectors Range/Phase
225A - 400A	(1) #1/0-750MCM CU/AL or (2) #1/0-250MCM CU/AL
600A	(2) #1/0-750MCM CU/AL or (4) #1/0-250MCM CU/AL
800A	(3) #1/0-750MCM CU/AL or (6) #1/0-250MCM CU/AL
1200A	(4) #1/0-750MCM CU/AL or (8) #1/0-250MCM CU/AL

Gutters

Ampere Rating	End Gutters (Minimum inches)	Side Gutters (Minimum inches)
400	12	7.9
600	12	7.9
800	12	7.9
1200	12	7.9

Maximum VB HP Ratings

Amp Rating	3 Phase			Single Phase	DC
	Volts			Volts	Volts
	240	480	600	240	250
30	7.5	15	20	3	5
60	15	30	50	10	10
100	30	60	50	15	20
200	60	125	50	-	40
400	50	50	50	-	50
600	50	50	-	-	-

Maximum VK HP Ratings

Amp Rating	3 Phase			Single Phase	DC
	Volts			Volts	Volts
	240	480	600	240	250
30	7.5	15	20	3	5
60	1.5	30	50	10	10
100	30	50	75	15	20
200	60	125	150	15	40

CSA Fuse Classes

Class	Amperes	Volts	Interrupting Ratings	I^2t , I_p	Circuits
H (code)	1-600A	250 and 600V or less AC	10,000A	-	Less than 10,000A available
K [®]	1-600A	250 and 600V or less AC	50,000A	-	Feeder circuits
J	1-600A	600V or less	To 200,000A	I^2t -Low I_p -Low	Feeder circuits (motor load small %)
RK1	1/10-600A	600V or less 250V or less	To 200,000A	I^2t -Slightly > J I_p -Slightly > J	Feeder circuits (motor load small %)
RK5	1/10-600A	600V or less 250V or less	To 200,000A	I^2t - > RK-1 I_p - > RK-1	Motor starting currents a factor
T	1-600A	300 and 600V or less AC	To 200,000A	I^2t -Low I_p -Low	Non-motor loads
L	601-5000A	600V or less	To 200,000A	I^2t -Low I_p -Low	Feeder circuits motor loads

Panelboards

Power and Distribution

Selection

Type F2

Maximum Panel Ampere	Unit Space (MLO)	Box Height				
400A	30"	60"	120/240Volts 1 Phase, 3 Wire	120/208 Volts 3 Phase, 4 Wire	600 Volts 3 Phase, 3 Wire	347/600 Volts 3 Phase, 4 Wire
600A	45"	75"				
800A	60"	90"				
1200A	60"	90"				

Branch Switches 600V Maximum^①

Rating Ampere	Maximum Voltage	Fusing (1)	Mounting Height F2 38" W
30/30A (VK)	600V	J	6.25(159)
60/60A (VK)			6.25(159)
100/100A (VK)			7.5(190)
200/200A (VK)			10(254)
30/30A, 60/60A, 100/100A (VB)			7.5(190) ^②
200A (VB)			10(254)
400A (VB)			15(381)
600A (VB)			15(381)

① Single or twin units as listed and are valid for class C or J fuses. If class R or T fuse provisions are required add per table above.
② Not applicable to VB style units 400A and 600A.

③ Use of auxiliary switch kit will require the use of a 7.5" (190) high unit for 30 and 60 Amp. switches.
④ Refer to Siemens for single phase and DC horsepower requirements.

⑤ Ratings are based on UL test procedure. CSA will not recognize ratings above 100Hp.

Panelboards

Modifications and Additions

Selection

Type F2

When required, special constructions or additions to standard panelboards may be specified for all **factory-assembled** Power and Distribution Panelboards. Below and on the next page are listed many of those available, for Type F2 panelboards. In no case do these apply to **Narrow** (Column) Width Lighting Panelboards.

1. Miscellaneous

ENCLOSURE TYPE
Type 1
Type 2 (Drip-proof)
Type 3R
Type 12

2. Painted Finish

Description
Touch-Up Paint (ASA61, Light Gray) 12 oz. aerosol can, Catalog Number TUP-61

3. Miscellaneous Accessories

Nameplate — laminated, engraved Tamper-Proof Screws
--

4. Devices Mounted on Gutter Cover Includes Device, Mounting — Wired or Unwired

Description
Toggle Switch — SPST or 3-way; 15A
Pilot Light — General Purpose, Neon or Incandescent
Pushbutton

5. Grounding of Panelboards^③

Non-Insulated Equipment Ground Bus Including Ground Lug
Insulated Equipment Ground Bus Including Ground Lug

6. Remote Control Switches^④ 600V AC

600V AC Ampere Rating	ASCO 920 Mechanically Held ^⑤		Siemens CLH Electrically Held ^⑥	
	2-Pole	3-Pole	2-Pole	3-Pole
30 60 75 100 150 ^⑦ 200 ^⑦ 225	Unit space 20"		Unit space 20"	

7. Increased Capacity Neutral

Ampere Rating		Unit Space (inches)
Phase	Neutral	
400	600	None
400	800	None
600	1200	None
800	1200	None

8. Main Bus

Standard main bus and ground bus is tin plated aluminum. For copper main bus, neutral bus and ground bus change prefix 'A' to 'C' on catalog number and contact your sales office for pricing.

9. Copper Lugs — For Main Lug Only Panels

Standard main lugs and neutral lugs are tin plated aluminum, UL & CSA listed for use with aluminum/copper cables. For copper Lugs in the mains and neutral for use with copper cables only, contact sales.

10. Feed-Through Lugs^① (One Set Per Panel)

Ampere Rating			Unit Space (Additional inches)
	3-Pole	2-Pole	MLO
400	Consult Sales Office	Consult Sales Office	10
600			10
800			17.5
1200			17.5

11. MLO Compression Lugs

Available as main lugs and neutral lug.

Ampere Rating	Aluminum (Specify Size)	Copper (Specify Size)	Deduct From Available Unit Space (inches)
400			5
600			5
800			5
1200			5

12. VK Switch Accessories

Item	Cat. No.
Fuse Pullers (2) 30/60 mp	FP2
100 amp	FP3
200 amp	FP4

13. Sentron TPS (SPD Modules)

100 KA	200 KA	300 KA
150 KA	250 KA	
Options		
Surge Counter		
Remote Indicator		

14. Customer Metering

Siemens Digital Metering with Remote Display SEM3 Embedded Metering
--

① For use on main lug, main breaker or main switch panels without subfeed breakers.
② For increase in panelboard height — Consult local sales office.
③ Ground bar is not installed in box.

④ For required unit space — consult local sales office. Price includes increased enclosure height if required.
⑤ Devices listed by Underwriters' Laboratories, Inc. When 2 wire control is required. Relay and Terminal Block (9" of unit space required).

⑥ For short circuit ratings with remote control switches consult sales office.
⑦ Panelboard short circuit rating is limited to 5,000 RMS symmetrical.

Panelboards

Modifications, Additions Replacements for Fusible Switches

Selection

Type F2 Replacement Units^{①②}

Amperes Rating	600 Volts J Fuses Cat. No.	Height in (mm)
----------------	----------------------------	----------------

VK Switch For Use With FPP6 Panelboard^{③④⑤⑨⑩}

Amperes Rating	VK Switch Cat. No.	Height in (mm)
30/30	VK23611JP	6.25 (159)
60/60	VK23622JP	6.25 (159)
100/100	VK33633JP	7.5 (90)
200/200	VK73644JP	10 (254)

VB Switch For Use With VB6 Panelboards^{⑥⑪}

Amperes Rating	VB Switch Cat. No.	Height in (mm)
30/30	V7E3611JP	7.5 (190)
60/60	V7E3622JP	7.5 (190)
100/100	V7E3633JP	7.5 (190)
200	V7F3604JP	10 (254)
400	V7H3605JP	15 (381)
600	V7H3606JP	15 (381)

Panelboard				
Tub Width	Depth	Panel Type	Replacement Max Amps	Note
30" - 36" - 42"	9"	OLD CDP	400	MCCB only.
	9.75"	OLD CDP	600	MCCB only.
32" - 38"	13.75"	CDP6/VB6	1200A 600A	MCCB series 6 connectors "VB" style units only (*)
38"	12.75"	SPP6/FPP6	1200A	MCCB series 6 connectors
			600A	"VK" or "VB" style (*)

Connecting Strap Kits^{⑩⑪}

Rating Amperes	VB Switch Cat. No.	VK Switch Cat. No.	HCP Switch Cat. No.
30/30	VB6-71	VK6-57	N/A
60/60		VK6-58	
100/100		N/A	
200		VK6-72	
200/200	N/A	VK6-72	
400-600	VB6-150	N/A	F6162DCAN
800-1200	N/A	N/A	

Blank Filler Plates^④

For use with Series 6 CDP Panelboards, S5, F2, FCI and FCII Switchboards.	
Height	SPP/FPP/CDP/VB 6
1.25"	6FPB01
2.50"	6FPB02
3.75"	6FPB03
5.00"	6FPB05
10.00"	6FPB10
15.00"	6FPB15

① For Series 6 Main Devices above 200A, add suffix MS to Catalog Number when ordering.

② When 2-Pole units are required, use 3-Pole.

③ Series 6 (VB6, CDP6) replacement units and connector kits also accommodates FCI and FCII distributions interiors.

④ Units installed after October 1991 will be FPP6 type.

⑤ Refer to Siemens for units equipped with auxiliary switches.

⑥ Price is for two brackets – to be included with filler plates.

⑦ To be used in tubs with 30-200A, VB units or fillers in 12⁵/₈" deep tub.

⑧ Can be used as fillers or in place of circuit breakers, VK or VB Switches.

⑨ Special order

⑩ Fusible switch kits include fusible switches and cover plates for switchboards and power panels. Connecting strap kits to be ordered separately.

⑪ Connecting strap kits include connecting straps and hardware. See Note 9 for cover plates.

⑫ The fusible switches and connecting strap kits are designed for standard 38"W sections. Additional covers are required for wider sections. Please consult your local sales contact.

Panelboards

Embedded Micro Metering Module™

Selection

SEM3 System Configured in Panelboards

The Siemens SEM3 system can be configured for factory installation in branch circuit monitoring application. This option can lower the installation time of the system for the installer while providing a factory warranted solution.

The SEM3 system can be factory installed in unit space in type P2 & S5 Siemens panel boards. Please note P1 and P3 configurations are not available at this time and the amount of unit space needed varies depending upon the application. Please note that lead time adders will apply and may vary depending upon the configuration of the system.

SEM3 for use in Siemens Panelboards

Available in a Type 1 and 2 rated enclosure



Controller

Each SEM3 Controller can monitor up to 45 circuits. Applications that require monitoring more than 45 circuits will require additional controllers.



Current Transformers (CTs)

Five sizes of CTs are available for use in the S5 panel: 50, 125, 250, 400, 600, 800 & 1200 amp. Each bracket supports a maximum of 3 CTs and is designed for the breaker selected (brackets are not interchangeable between breaker frames). Each CT will be attached to a data module that is placed in the meter racks.



Meter Racks

All meter racks will be installed next to the SEM3 controller unit space. The 21 space meter rack is used as a default option where possible.

NOTE: Monitoring of 45 circuits will require: two 21 position racks and one 3 position rack

Other Considerations

Configuration: Data modules from CTs monitoring a circuit breaker must be mounted adjacent to one another in the meter rack. Any field changes to the factory configuration must take this into account.

Start-up & Commissioning: Siemens can provide these services. Contact your local Siemens sales office for more details.

Panelboards

Panel Skirts/System Types, AC & DC Voltages

Conduit Enclosing Shield (Panel Skirts)

Sheet metal to cover conduits above or below a standard panelboard box.

Skirt Length	Width	Depth
8, 9, 11, 12	20.00	5.75
14, 17, 18, 23, 25	20.00	5.75
26, 27, 28, 29, 30, 31, 32, 33, 34, 35, 36	20.00	5.75
37, 38, 39, 40, 41, 42, 43, 44	20.00	5.75
8, 9, 11, 12	24.00	7.75
14, 17, 18, 23, 25	24.00	7.75
26, 27, 28, 29, 30, 31, 32, 33, 34, 35, 36	24.00	7.75
37, 38, 39, 40, 41, 42, 43, 44	24.00	7.75

Panel Skirts Standard Length

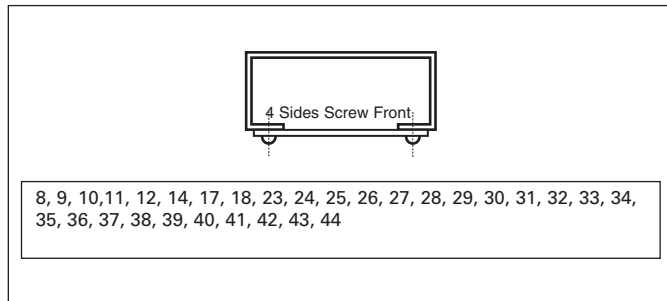

Busing

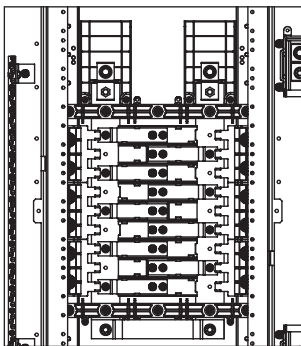

Single-phase

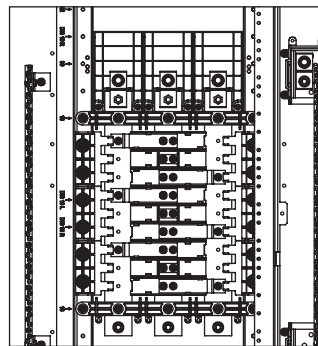

Three-phase

AC Voltages

1 phase, 2 wire

120V 1 phase, 2 wire
240V 1 phase, 2 wire

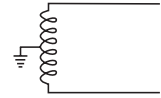

1 phase, 3 wire

120/240V 1 phase, 3 wire

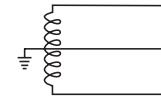

1 phase, 2 wire, Wye

277V 1 phase, 2 wire

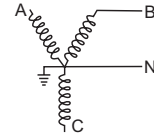

1 phase, 2 wire, Delta

480V 1 phase, 2 wire

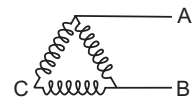

1 phase, 3 wire, Delta

240/480V 1 phase, 3 wire

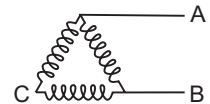

3 phase, 4 wire, Wye

208Y/120V 3 phase, 4 wire
480Y/277V 3 phase, 4 wire
600Y/347V 3 phase, 4 wire

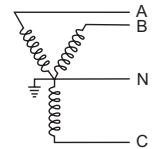

3 phase, 4 wire, Delta

240/120V 3 phase, 4 wire
480/240V 3 phase, 4 wire

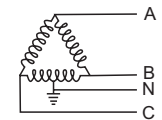

3 phase, 3 wire, Delta

240V, 3 phase, 3 wire
480V, 3 phase, 3 wire
600V, 3 phase, 3 wire
240V, 3 phase, 3 wire, grounded B
480V, 3 phase, 3 wire, grounded B
600V, 3 phase, 3 wire, grounded B

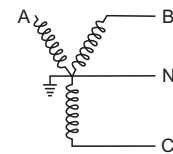
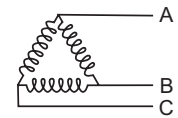

1 phase, 3 wire, Wye

208Y/120V 1 phase, 3 wire
480Y/277V 1 phase, 3 wire

DC voltage

1 phase, 2 wire

125Vdc, 2 wire

(Up to 125Vdc, MLO option only.)

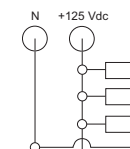

Panelboards

Type HCP Switchboard and Power Panel Units, Accessories

Selection

Features

CSA certified under file #24563 and UL Listed under file #E6849 Vol 1, Sect. 8 400-1200A ratings
Visible contacts
Field installable shunt trip and auxiliary switch accessory kits
Installs in existing Siemens switchboards
Suitable for use on systems with up to 200,000A available fault current, RMS symmetrical when equipped with Class J or Class L fuses

Group mounts with other 30A through 600A switches, and 100 through 1200 amp frame breakers

Allows 800A and 1200A switches in standard 38" wide distribution sections in either main or branch configurations
16¼" mounting height is the smallest 1200A design in the industry, allowing up to 4 units in one vertical section
Field reversible horizontal mounting design for left or right hand cabling
Handle can be padlocked in the OFF position with up to three padlocks with 5/16" hasps. A cover padlocking provision is also supplied



3-Pole, Horizontal Mount ①

Catalogue Number	Maximum Ampere Rating	Maximum AC Voltage Rating ^②	Fuse Class	Dimensions (inches*)			Horsepower Rating						
							240V		480V		600V		250V DC
				H	W	D	Std	Max	Std	Max	Std	Max	
HCP367HJ400	400	600	J	16.25	17.22	7.38	50	125	100	250	125	350	40
HCP367HJ600	600	600	J	16.25	17.22	7.38	75	200	150	400	200	400	40
HCP327HT	800	240	T	16.25	17.22	7.38	100	250	—	—	—	—	50
HCP367H	800	600	L	16.25	17.22	7.38	100	250	200	500	250	500	50
HCP328HT	1200	240	T	16.25	17.22	7.38	100	250	—	—	—	—	50
HCP368H	1200	600	L	16.25	17.22	7.38	100	250	200	500	250	500	50

3-Pole, Vertical Mount

HCP367VJ400	400	600	J	17.00	16.25	7.38	50	125	100	250	125	350	40
HCP367VJ600▲	600	600	J	17.00	16.25	7.38	75	200	150	400	200	400	40
HCP327VT	800	240	T	17.00	16.25	7.38	100	250	—	—	—	—	50
HCP367V	800	600	L	17.00	16.25	7.38	100	250	200	500	250	500	50
HCP328VT	1200	240	T	17.00	16.25	7.38	100	250	—	—	—	—	50
HCP368V	1200	600	L	17.00	16.25	7.38	100	250	200	500	250	500	50

Accessories

Terminal Connectors (one lug per kit)

Ampere Rating	Catalogue Number	Connector Wire Range
400-600A	TA2K500	(2) #1 AWG-500 kcmil (Cu or Al)
400-600A	TC2K500	(2) #1 AWG-500 kcmil (Cu only)
400-800A	TA3K500	(3) #1 AWG-500 kcmil (Cu or Al)
400-800A	TC3K350	(3) #1 AWG-350 kcmil (Cu only)
800-1200A	TA4H500	(4) #2 AWG-500 kcmil (Cu or Al)
800-1200A	TA3H750	(3) 500-750 kcmil (Cu or Al)

Auxiliary Switch Kits

Contact Ampere Rating	Maximum Voltage		Switch Mounting	Contacts	Catalogue Number
	AC	DC			
15A	480	125	Left Pole	1NO/1NC	A01HCP4▲
15A	480	125	Right Pole	1NO/1NC	A01HCP4

Shunt Trip Kit

Control Voltage		Catalogue Number
AC	DC	
120	—	HCPST120
240	—	HCPST240▲
277	—	HCPST277
480	—	HCPST480▲

*For inches / millimeters conversion, multiply inches by 25.4.

Switchboard Connection Strap Kit ①

Switch Ampere Rating	Catalogue Number
400-1200A	F6162DCAN

▲ Built to order. Allow 6-8 weeks for delivery.
① For horizontal mounting only in either 38" wide min switchboards or F2 power panelboards.

T Fuse Adapter Kits (one per pole)

Catalogue Number	Description
TFAK72	800A, 300V AC
TFAK75	800A, 600V AC
TFAK82	1200A, 300V AC

HCP Replacement Handle Kit

(For use on all HCP switches)

SW Ampere Rating	Catalogue Number
400-1200A	HCPHK

Compression Lug Adapter Kit

The use of this kit provides for the mounting of up to four lugs per phase. Each kit accepts lugs with (2) 3/8" diameter mounting holes on 1" centers. One kit per pole line or load is required. Lugs are not provided.

Ampere Rating	Catalogue Number
400-1200A	HCPCLP

② Both 240 and 600V AC switches are also rated 250V DC max.

Panelboards

Type HCP Switchboard Units

Dimensions

Horizontal Mount Drawing

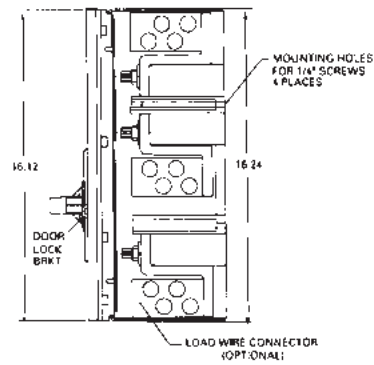
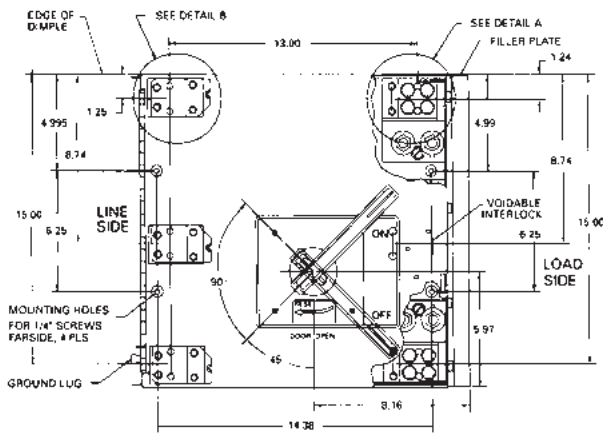
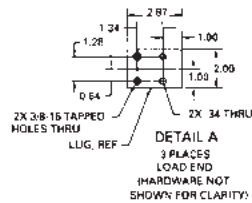
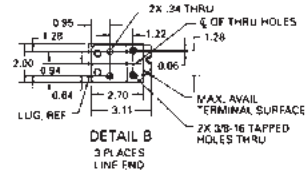
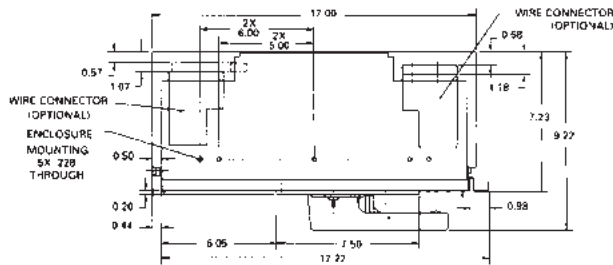

Group Mounting Assembly (Horizontal Mount Only)

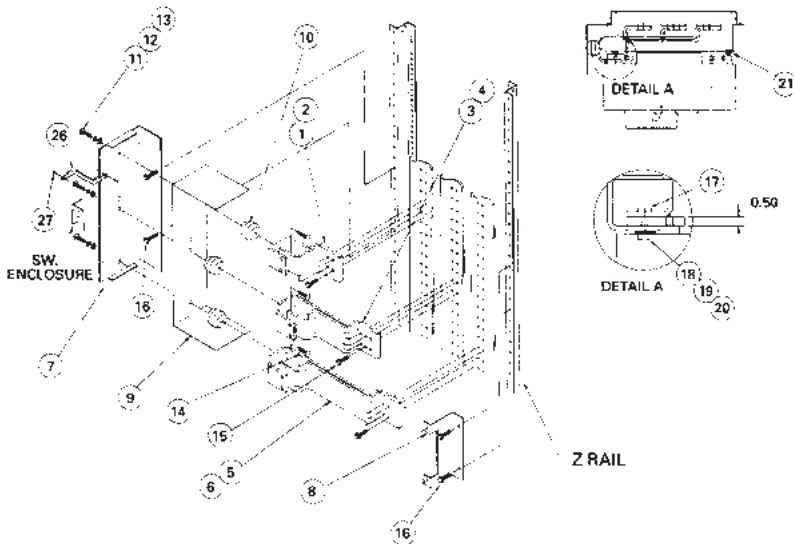

Note: Right exit shown, rotate 180° for left exit
Note: Items 26 & 27 are used to ground the switch enclosure (Route bonding wire along flange)

Item	Parts Supplied in Connection Strap Kit Cat. No. F6162D	Qty.
1-2	A/C Ø Strap (Short)	1ea.
3-4	B Ø Strap	1ea.
5-6	A/C Ø Strap (Long)	1ea.
7-8	Switch Mounting Bracket	1ea.
9	Insulation	1
10	1-3/8" Insulator	3
11	3/8-16 X 3/4" HHMS	3
12	3/8" Lock Washer	3
13	3/8" Flat Washer	3
14	3/8-16 X 3/4" RHSNB	3
15	Strap Bus Hardware Kit	2
16	1/4-28 X 3/8" SHWHSW	4
17	5/16-18 Insert	6
18	5/16-18 X 1" SRHMS	6
19	5/16 Flat Washer	6
20	5/16 Lock Washer	6
21	1/4-20 X 1" SRHMS	2
26	Ground Bracket	1
27	10-32 X 1/4" SHWHSW	2

Panelboards

Circuit Breaker / Column Type

General

Type C1

240 Volts AC Maximum
250 Ampere Mains
250 Ampere Maximum Branch
UL Short Circuit Rating –
200,000 IR Maximum

Branch Breaker Symmetrical
Interrupting Rating

Based on Underwriters' Test Procedure

Type C2

480Y/277 Volts AC Maximum
250 Ampere Mains
250 Ampere Maximum Branch
UL Short Circuit Rating –
100,000 IR Maximum

Meets NEC wire bending requirement, section 312-6.

Panelboards

Listed by Underwriter's Laboratories, Inc., under "Panelboards" File #E2269.

Meets Federal Specification W-C375B/Gen.

Service

240 Volts Maximum. 1-Phase, 3-Wire, or 3-Phase, 4-Wire.

Panelboards Fronts and Doors

Standard panelboards are furnished with trim with a flush door lock. All are factory assembled for ease of installation. Fronts are fabricated from code gauge steel and finished ANSI-61.

Main Breakers C1

BL, BLH and HBL frame breakers are mounted horizontally. All other frames are mounted vertically.

Main Breakers C2

BQD frame breakers are mounted horizontally. All other frames are mounted vertically.

Boxes

C1 — 7 $\frac{7}{8}$ " wide, 5 $\frac{3}{4}$ " deep.

C2 — 8 $\frac{1}{2}$ " wide, 5 $\frac{3}{4}$ " deep.

Branch Breaker Side Gutters

Type	Circuit Breaker	Side Gutter (inches)
C1	BL, BLH, HBL	3.505
C2	BQD	3.5

Weight—Approximate

Total panelboard weight when filled with a normal quantity of breakers and accessories is:

*About 3 lbs. per inch of box height.

Gauge Steel Boxes

Type	Width	Height	Gauge Steel
C1	7 $\frac{7}{8}$ "	48", 73", 85"	#14
C2	8 $\frac{1}{2}$ "	48", 73", 85"	#14

Fronts

C1	7 $\frac{7}{8}$ "	48", 73", 85"*	#14
C2	8 $\frac{1}{2}$ "	48", 73", 85"*	#14

*Note: Feed thru lugs and subfeed breaker not available for this height.

Main Breaker Connectors

Ampere Rating	Connectors suitable for Cu or Al
100	(1) #14-1/0 AWG
125	(1) #4-1/0 AWG
225	(1) #6 AWG-300 kcmil
250	(1) #4 AWG-350 kcmil Al (1) #6 AWG-350 kcmil Cu

Main Lugs

125	(1) #6 AWG-350 kcmil
250	(1) #6 AWG-350 kcmil

① Connector ranges indicated do not apply to all main breaker types. Refer to molded case circuit breaker standard pressure wire connectors in the breaker section of this catalog for the wire ranges for a specific breaker frame.

Panelboards

Circuit Breaker / Column Type

Selection

Branch Breaker Selection C1

Breaker Type	Available Ampere Rating	Availability			Maximum Interrupting Rating (kA)		
		1-Pole	2-Pole	3-Pole	120V	120/240V	240V
BL (120V)	15, 20, 30, 40, 50, 60	✓	✓	✓	—	10	—
	70	✓	✓	✓	—	10	—
	70, 80, 90, 100	—	✓	✓	—	10	—
BLF (GFCI)	15, 20, 30	✓	✓	—	10	—	—
	40, 50, 60	—	✓	—	10	—	—
BLE (EQGFI)	15, 20, 30	✓	✓	—	10	—	—
BGL (SWN)	15, 20, 30	—	✓	✓	10	—	—
BLR (240V)	15, 20, 30, 40, 50, 60	—	✓	—	—	—	10
	70, 80, 90, 100	—	✓	—	—	—	10
BLH (120V)	15, 20, 30, 40, 50, 60	✓	✓	✓	—	22	—
	70	✓	✓	✓	—	22	—
	70, 80, 90, 100	—	✓	✓	—	22	—
BLHF (GFCI)	15, 20, 30	✓	✓	—	—	22	—
	40, 50, 60	—	✓	—	—	22	—
HBL	15, 20, 30, 40, 50	✓	✓	✓	—	65	65
	60, 70, 80, 90, 100	—	✓	✓	—	65	65

Subfeed Breakers — Limit One Per Panel® C1 (Not available for 42 circuit panels)

ED4	15, 20, 30, 40, 50, 60, 70, 80, 90, 100	—	✓	✓	—	—	65
	110, 125	—	✓	✓	—	—	65
HED4	15, 20, 30, 40, 50, 60, 70, 80, 90, 100	—	✓	✓	—	—	65
	110, 125	—	✓	✓	—	—	100
QR2	100, 110, 125, 150, 175, 200, 225	—	✓	✓	—	—	10
FXD6	70, 80, 90, 100, 110, 125, 150, 175, 200, 225, 250	—	✓	✓	—	—	65
HFD6®	70, 80, 90, 100, 110, 125, 150, 175, 200, 225, 250	—	✓	✓	—	—	100

Alternate Main Breaker Selection ③③ C2

Ampere Rating	Breaker Type	IR	Catalogue Number	Available Trip Values
100	BQD	14	BD	50, 60, 70, 80, 90, 100
	ED4	18	E4	50, 60, 70, 80, 90, 100
	ED6	25	E6	50, 60, 70, 80, 90, 100
	HED4	42	H4	50, 60, 70, 80, 90, 100
	HHED6	65	H6	50, 60, 70, 80, 90, 100
125	ED4	18	E4	110, 125
	ED6	25	E6	110, 125
	HED4	42	H4	110, 125
	HHED6	65	H6	110, 125
225	FXD6	35	FX	70, 80, 90, 100, 110, 125, 150, 175, 200, 225
	HFD6	65	HF	170, 80, 90, 100, 110, 125, 150, 175, 200, 225
250	FXD6	35	FX	250
	HFD6	65	HF	250

Branch Circuit Breakers C2

Breaker Type	Available Ampere Rating	Availability			Maximum Interrupting Rating (kA)		
		1-Pole	2-Pole	3-Pole	277V	480/277V	480V
BQD	15, 20, 30, 40, 50, 60	✓	✓	✓	14	14	—
	70, 80, 90, 100	✓	✓	✓	14	14	—

Subfeed Breakers — Limit One Per Panel® C2 (Not available for 42 circuit panels)

ED4	15, 20, 30, 40, 50, 60, 70, 80, 90, 100	—	✓	✓	—	18	18
	110, 125	—	✓	✓	—	18	18
ED6	15, 20, 30, 40, 50, 60, 70, 80, 90, 100	—	✓	✓	—	—	25
	110, 125	—	✓	✓	—	—	25
HED4	15, 20, 30, 40, 50, 60, 70, 80, 90, 100	—	✓	✓	—	—	42
	110, 125	—	✓	✓	—	—	42
FXD6	70, 80, 90, 100, 110, 125, 150, 175, 200, 225, 250	—	✓	✓	—	—	35
HFD6	70, 80, 90, 100, 110, 125, 150, 175, 200, 225, 250	—	✓	✓	—	—	65

① No increase in box height. Space is already built into C1 panel.

② BL, BLH, HBL and BQD are horizontally mounted. All others vertically mounted.

③ Interchangeable trip breakers such as FD6 and HFD6 cannot be back fed. Must be top feed only.

Panelboards

Circuit Breaker / Column Type, Modifications and Additions

Selection

Type C1/C2

When required, special constructions or additions to standard panelboards may be specified for factory-assembled column panelboards.

Box Modifications

Description
Gasketed
Metal Card Holder
Welded Metal Card Holder
Nameplate
Al Ground Bar
Cu Ground Bar
Insulated Al Ground Bar
Insulated Cu Ground Bar

Interior Modifications

Description
Feed-Thru Lugs
Cu Neutral Lugs
Cu main Lugs 125A
Cu main Lugs 250A

Box Sizing Chart

Certain modifications such as subfeed breakers and feed-thru lugs require additional unit space. Use this chart to determine proper enclosure size.

Panel Configuration	Box Height (inches)
All MLO 18 Circuit	48
All MLO 30 Circuit	73
All MLO 42 Circuit	85
All MLO 18 Circuit with feed-thru lugs	73
All MLO 30 Circuit with feed-thru lugs	85
All MLO 18 Circuit with subfeed breaker	73
All MLO 30 Circuit with subfeed breaker	85
All Main Breaker 18 Circuit	48
All Main Breaker 30 Circuit	73
All Main Breaker 42 Circuit	85
All Main Breaker 18 Circuit with feed-thru lugs	73
All Main Breaker 30 Circuit with feed-thru lugs	85
All Main Breaker 18 Circuit with subfeed breaker	73
All Main Breaker 30 Circuit with subfeed breaker	85

Breaker Kits and Accessories

Kit Number	Description	Contents
MBKQRC1FK	C1 Filler for QR in Main position 1PH or 3PH	Kit contains all cover plates necessary to change from QJ to QR both 2 and 3-pole breakers.

Column Extension

Available in various standard lengths, extensions are 5¼ inches deep and 7 inches wide.

Height (inches)	Catalogue Number ^①
14	LXX-14
20	LXX-20
26	LXX-26
32	LXX-32
38	LXX-38
41	LXX-41
44	LXX-44
53	LXX-53
56	LXX-56
62	LXX-62
65	LXX-65
68	LXX-68
74	LXX-74
80	LXX-80
86	LXX-86

Pull Boxes

Two styles of pull boxes are available, top and front mounted. When the panel and its extensions are mounted in a structural WF beam a front mounted pull box is required. When the panels are surface mounted, a top mounted pull box may be used. Provisions are made so that the neutral bar may be mounted in the pull box when required. (Front mounted pull box dimensions are 14" H. X 20" W.)

Description	Catalogue Number ^①
Top Mount	LXXP-T
Front Mount ^②	LXX50-F

Panelboards

Circuit Breaker / Column Type

Selection

Conduit Enclosing Shield (Panel Skirts)

Sheet metal to cover conduits above or below a standard panelboard box.

Skirt Length	Width	Depth
8, 9, 11, 12	20.00	5.75
14, 17, 18, 23, 25	20.00	5.75
26, 27, 28, 29, 30, 31, 32, 33, 34, 35, 36	20.00	5.75
37, 38, 39, 40, 41, 42, 43, 44	20.00	5.75
8, 9, 11, 12	24.00	7.75
14, 17, 18, 23, 25	24.00	7.75
26, 27, 28, 29, 30, 31, 32, 33, 34, 35, 36	24.00	7.75
37, 38, 39, 40, 41, 42, 43, 44	24.00	7.75

Panel Skirts Standard Length

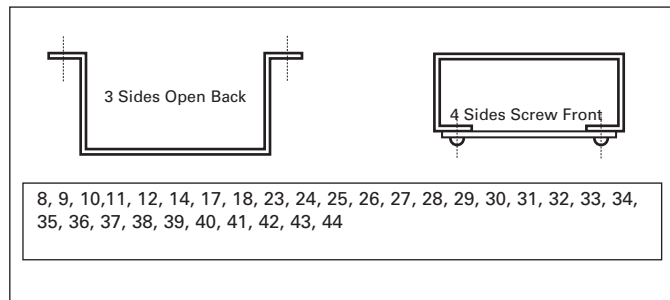

① Available only as a main switch for non-service equipment applications. Not available for branch devices.

Panelboards

Enclosure/System Types, AC & DC Voltages

Selection

Type 1

- Flush or surface mount.
- Galvanized steel with removable end walls –blank or with knockouts to order.
- Box sizes: 20" W x 5.75" D x 33", 50", 59" or 69" H (510 W x 145 D x 838, 1270, 1500 or 1753mm H). Box can be rotated 180° to accommodate conduit feed.
- Enclosure and chassis mounting instructions are found in supplied literature.
- Chassis mounts directly onto studs in the enclosure.
- Trim finished with gray powder coat paint over phosphatized steel (ANSI 61).
- Door and door-in-door configurations with locks.
- Door locks use key #2A1910-2.
- Circuit directory card is located on the inside of the door.
- Trim screws are concealed.

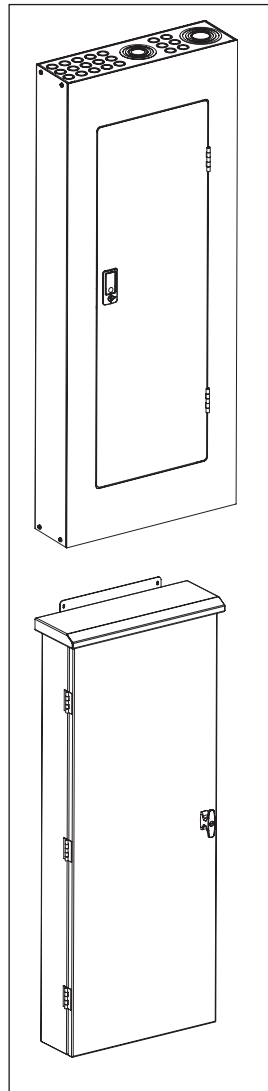

Type 3R

Surface mount only.
 Finished with gray powder coat paint over phosphatized steel (ANSI 61).
 Bottom feed only, no knockouts
 Box sizes: 20" W x 7.7" D x 34.5", 51.5", 60.5" or 70.5 H (510 W x 195 D x 876, 1310, 1535 or 1791mm H).
 Enclosure and chassis mounting instructions are found in supplied literature
 Chassis mounts directly onto studs in the enclosure.
 Gasketed door has vault handle with lock.
 Door locks use key #2A1910-1.
 Circuit directory card is located on the inside of the door.

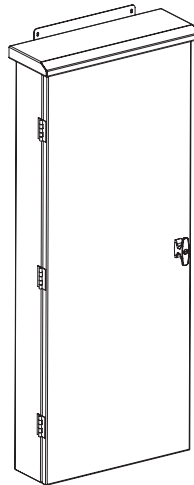

Busing

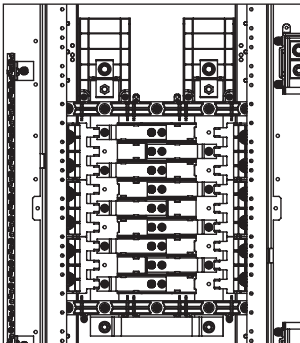

Single-phase

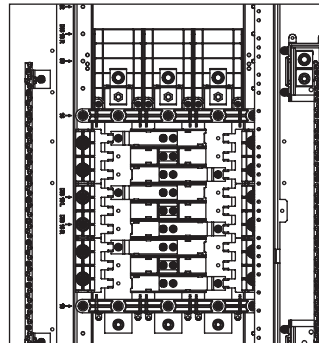

Three-phase

AC Voltages

1 phase, 2 wire
 120V 1 phase, 2 wire
 240V 1 phase, 2 wire

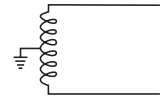

1 phase, 3 wire
 120/240V 1 phase, 3 wire

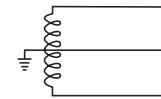

1 phase, 2 wire, Wye
 277V 1 phase, 2 wire

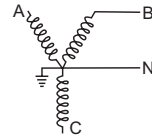

1 phase, 2 wire, Delta
 480V 1 phase, 2 wire

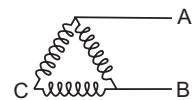

1 phase, 3 wire, Delta
 240/480V 1 phase, 3 wire

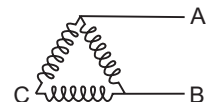

3 phase, 4 wire, Wye
 208Y/120V 3 phase, 4 wire
 480Y/277V 3 phase, 4 wire
 600Y/347V 3 phase, 4 wire

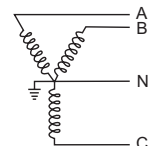

3 phase, 4 wire, Delta
 240/120V 3 phase, 4 wire
 480/240V 3 phase, 4 wire

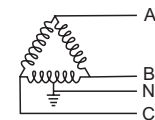

3 phase, 3 wire, Delta
 240V, 3 phase, 3 wire
 480V, 3 phase, 3 wire
 600V, 3 phase, 3 wire
 240V, 3 phase, 3 wire, grounded B
 480V, 3 phase, 3 wire, grounded B
 600V, 3 phase, 3 wire, grounded B

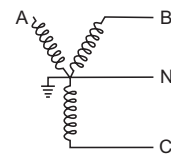
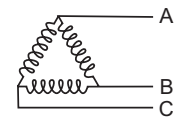

1 phase, 3 wire, Wye
 208Y/120V 1 phase, 3 wire
 480Y/277V 1 phase, 3 wire

DC voltage

1 phase, 2 wire
 125Vdc, 2 wire

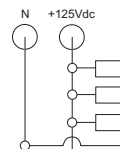

(Up to 125Vdc, MLO option only, SCCPB 40A or less.)

Panelboards

Dimensions and Panelboard Configurations

Selection

NEMA 1 and 3R Enclosure Dimensions

Encl. Type	Encl. Height	Dimensions (inches)				DH	RH	SH	DW	D
		H	HC	MH	CH					
NEMA 1	33	33.0	N/A	29.0	26.0	28.9	25.0	2.0	20.0	5.7
	50	50.0	N/A	43.0	40.0	37.9	39.0	3.5	20.0	5.7
	59	59.0	N/A	52.0	49.0	46.9	48.0	3.5	20.0	5.7
	69	69.0	N/A	62.0	59.0	56.9	58.0	3.5	20.0	5.7
NEMA 3R	33	33.0	34.5	35.5	26.0	28.9	25.0	2.0	20.0	6.3
	50	50.0	51.5	52.5	40.0	37.9	39.0	2.0	20.0	6.3
	59	59.0	60.5	61.5	49.0	46.9	48.0	2.0	20.0	6.3
	69	69.0	70.5	71.5	59.0	56.9	58.0	2.0	20.0	6.3

Available panelboard configurations

Based on enclosure height, panel amp rating and number of branch circuit positions

Encl. height (inches)	Panel amp rating	Branch positions	Available configurations
33"	30-200	18	· Main lug only, with or without feed-through lugs · Non-fused disconnect, no loadside options
		30	· Main lug only, no loadside options
50"	30-60	18	· 30 through 60A fused main disconnect with or without feed-through lugs or TVSS device
		30	· 30 through 60A fused main disconnect with or without feed-through lugs or TVSS device
		42	· 30 through 60A fused main disconnect with or without feed-through lugs or TVSS device
	70-200	18	· 70 through 200A fused main disconnect with or without feed-through lugs or TVSS device
		30	· 70 through 200A fused disconnect with or without feed-through lugs
	30-200	18	· Main lug only with TVSS device · Non-fused disconnect, with feed-through lugs or TVSS device
		30	· Main lugs only, with feed-through lugs or TVSS device · Non-fused disconnect, with or without feed through lugs
		42	· Main lug only, with or without feed-through lugs or TVSS device · Non-fused disconnect, with or without feed-through lugs
	225-400A	18	· Main lug only, with or without feed through lugs or TVSS device · Non-fused disconnect, with or without feed-through lugs
		30	· Main lug only, with or without feed-through lugs
59"	70-200	30	· 70 through 200A fused main disconnect, with TVSS device
		42	· 70 through 200A fused main disconnect with or without feed-through lugs or TVSS device
	225-400A	42	· Non-fused disconnect with TVSS device
		18	· Main lug only with loadside disconnect · Non-fused disconnect, with TVSS device · 225 through 400A fused disconnect with or without feed-through lugs or TVSS device
		30	· Main lug only, with TVSS device · 225 through 400A fused disconnect, with no loadside options
		42	· Main lug only, with or without feed-through lugs or TVSS device · Non-fused disconnect, with no loadside options
69"	225-400A	18	· Non-fused disconnect, with loadside disconnect
		30	· Main lug only with loadside disconnect · 225 through 400A fused disconnect with feed-through lugs or TVSS device
		42	· Non-fused disconnect, with or without feed through lugs or TVSS device · 225 through 400A fused main disconnect, with or without feed-through lugs or TVSS device

Panelboards

NEMA 1 and NEMA 3R

Dimensions

NEMA 1 Enclosures and Interior

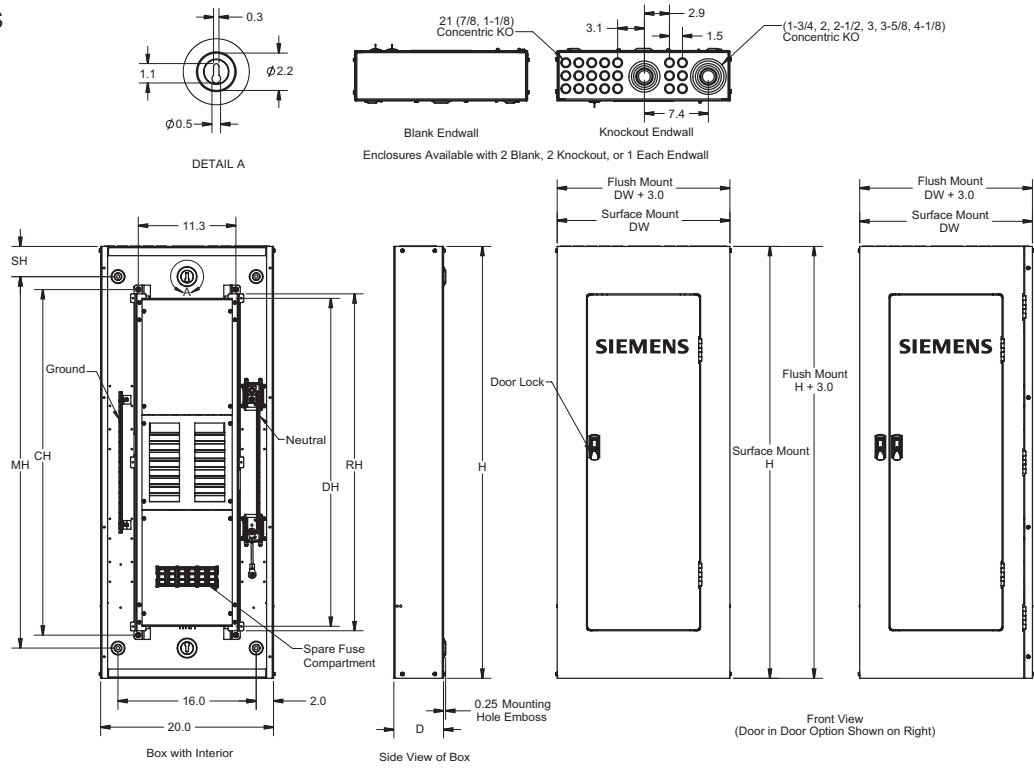

NEMA 3R Enclosures Interior same as NEMA 1

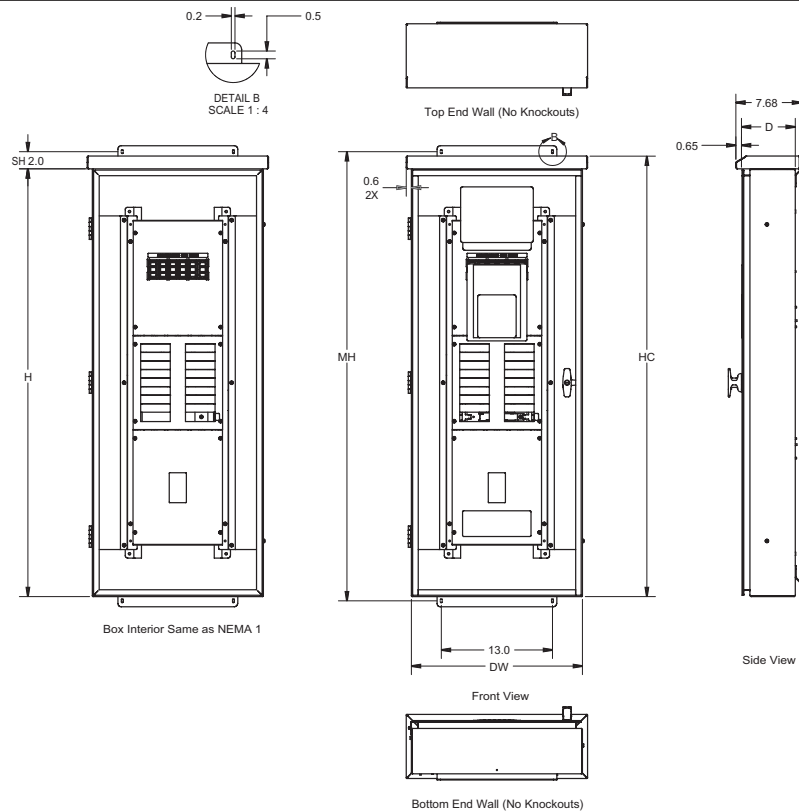

Panelboards

Fuse Curves

Selection

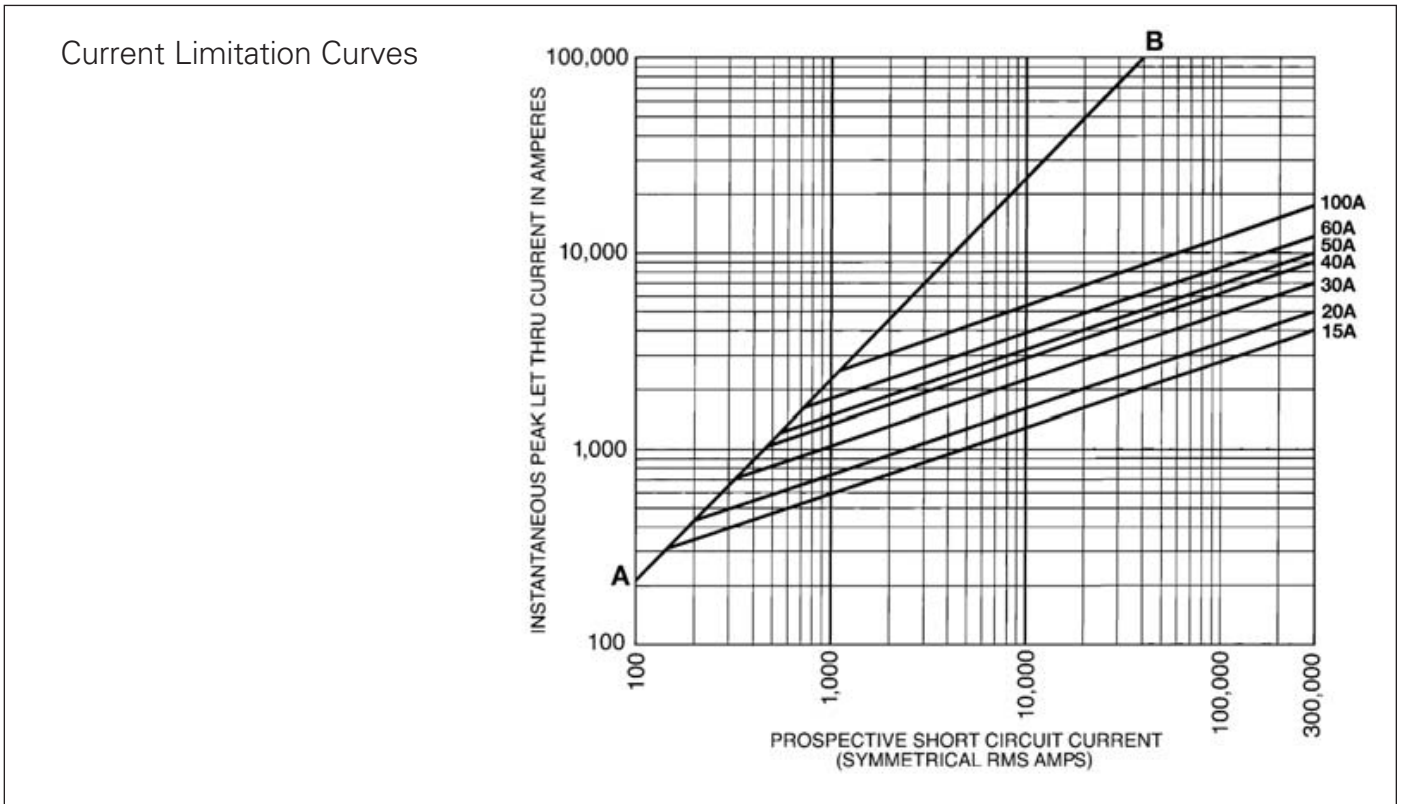
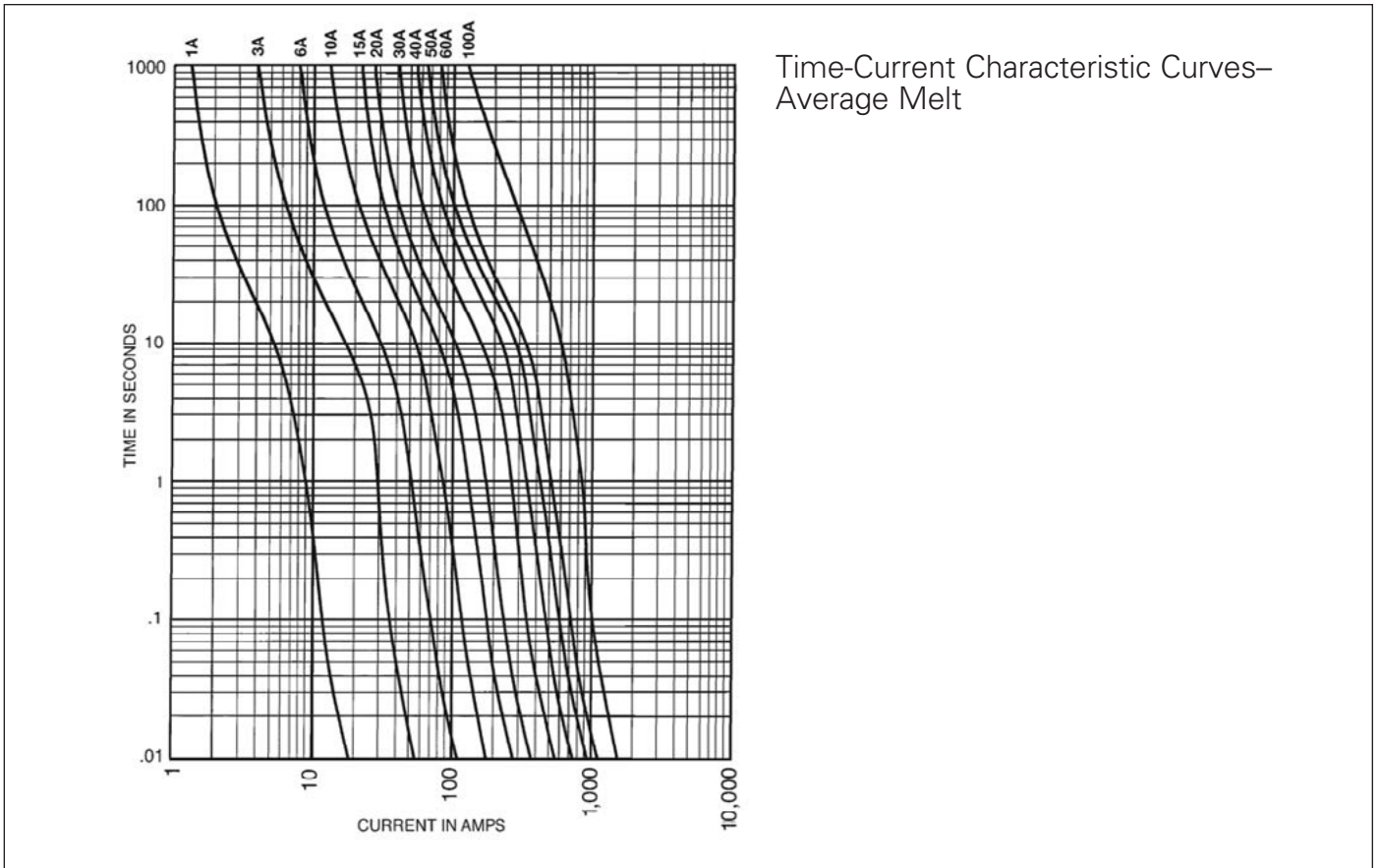

Notes
