

### Contactor for capacitor switching: Type: 3TS1722-0A..5-8K

CE IEC 60947-4-1

	<b>Warning:</b> <b>Hazardous Voltage can cause Electric Shock and burns.</b> Disconnect Power before proceeding with any work on this equipment
	Avoid operation during under voltage conditions. Switch only onto discharged capacitors. Manual operation not permitted for function testing.
	Commissioning and maintenance by qualified personnel only. Follow the operating instructions Do not remove precharging resistors. If contactor is switched on load without resistor, it may cause damage to the contactor

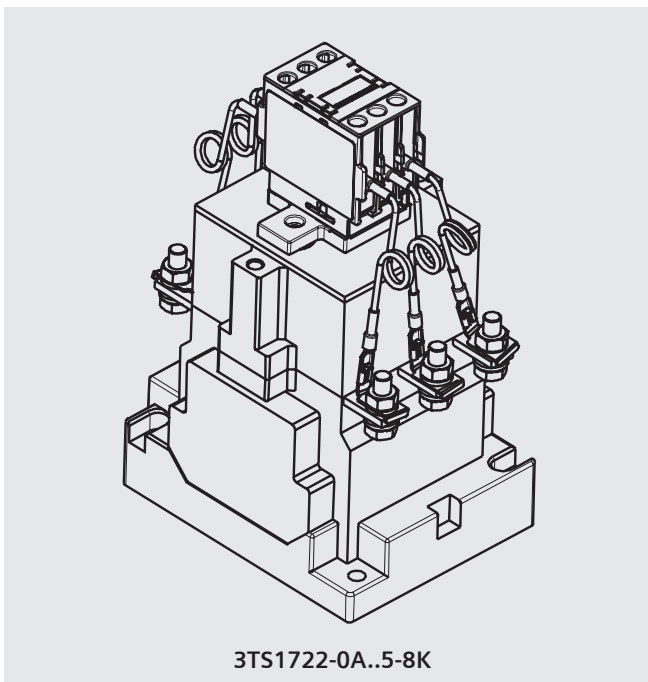

- **Maximum back-up fuse rating:** For Type-1 Coordination Type-3NA7 as per IEC 60269  
 operational class gG 125A

#### ii) Aux Circuit:

**Inbuilt: Auxiliary Contacts**  
2NO+2NC

**Aux Contact Rating:**  
3TY7

- le AC-15 = 3.6 A at 415 V AC.
- le DC-13 = 0.48 A at 220 V DC.

#### iii) Control circuit:

- Control voltage is marked on the coloured identification tag on the coil.

#### Note:

- The voltage is to be maintained within 0.85 to 1.1 x rated coil voltage.
- Operation in under voltage conditions to the coil may cause damage to the coil/contactor.
- Maximum back-up fuse rating for control circuit = 16A = 6A if relay contact is in the control circuit.

### A. Technical Data

#### i) Main circuit:

The capacitors are precharged during pick-up via early-make contacts and integrated pre-charge resistors before the main contacts close.

This combination is used for switching of Individual capacitor for power factor correction of single loads or for switching capacitor banks in parallel in centralized group power factor correction system.

- Insulation Voltage  $U_i = 690$  V AC,  
**Temperature:** Storage -25 to +55°C  
 Service (without derating) -25 to +40°C

Use the devices with the declared capacitor bank ratings only.

Contactor Type	Load of contactor when switching 3ph-AC capacitor kVar at 415/440V,50Hz
3TS1722-0A .. 5-8K	50

- **Switching frequency in Make/Break operations:**  
100 operating cycles/hr.

#### iv) Internal connection diagram

Connection Details for 3TS1722.. is shown in figure 1

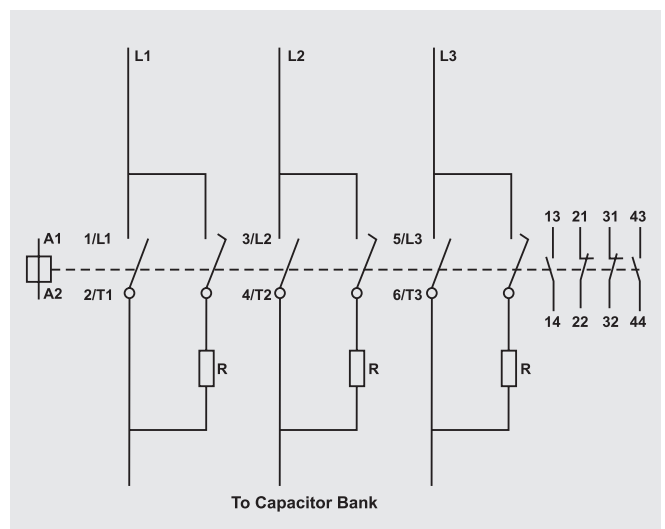

Fig. 1

## Permissible Conductor Size: Main Terminals

Termination Data - Contactor	3TS1722-0A .. 5-8K
Finely Stranded with ring type cable lug	1 x 35mm <sup>2</sup> / 2 x 16mm <sup>2</sup>
Terminal bar (max. width)	12mm
Screw Size	M6
Tightening Torque	4-6 N-m

## B. Installation

1. Permitted mounting positions are indicated in Fig.2
2. The unit is suitable for screw mounting on flat vertical surface with two M4 screws. Always use plain and spring washers.

Note: Install the unit in housing if it is exposed to dust, dirt, contamination or aggressive atmosphere.

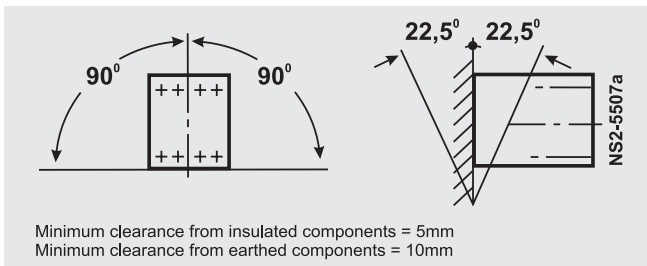

Fig. 2

## E. Overall Dimensions

Dimensions in mm : 50 kVAr (3TS1722-0A .. 5-8K)

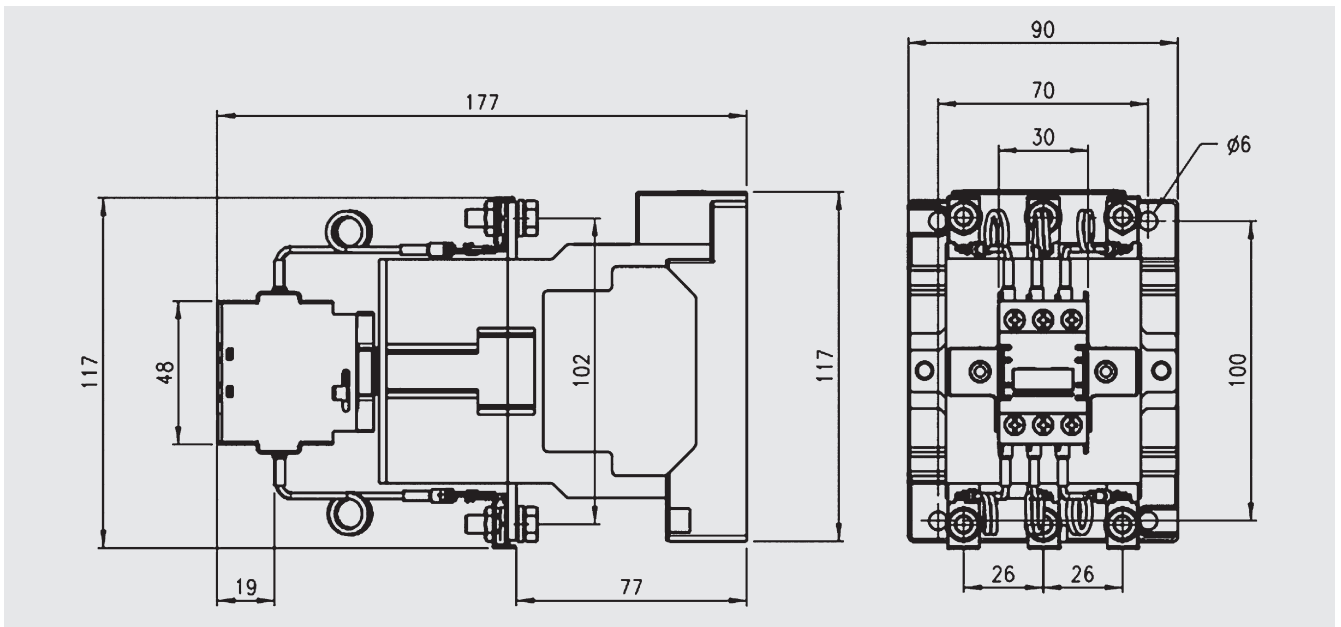

Fig. 3

## C. Maintenance

- Remove dust by suction.
- Replacement of coil available as spare.

Order Code	AC Coil Voltage
3TY7 463-0AF0	110
3TY7 463-0AP0	230
3TY7 463-0AR0	415

- Spare contact kits available.
- Contact Siemens Sales office for details.
- Handle the resistor wires carefully.

## D. Note:

Normally the power factor controller in APFC panels, has the provision for adjustment under voltage cut out with respect to voltage and time. Please ensure that the controllers are present as per values given in the table below

Coil Voltage	Controller settings	
	Under Voltage	Actuating time
110V	≥ 94 V	< 0.1 sec
230V	≥ 196 V	< 0.1 sec
415V	≥ 353V	< 0.1 sec

In case, Power factor controller does not have the provision of above settings, it is recommended to provide a separate undervoltage monitor having settings as per table, to ensure satisfactory performance of the contactors.

For further details on such an undervoltage monitor, please contact nearest Siemens office

## Disposal

Siemens product are environment friendly, which predominantly consist of recyclable materials.

For disposals we recommend disassembling and separation into following materials:

**METALS:** Segregate into Ferrous & Non Ferrous types for recycling through authorised dealer.

**PLASTICS:** Segregate as per material type for recycling through authorised dealer. Because of the long lifetime of Siemens products the disposal guidelines may be replaced by other national regulations when taking the product out of service.

The local customer care service is available at any time to answer disposal-related questions