

An aerial photograph of a modern park. A wide, light-colored, winding path curves through a lush green lawn. The path is bordered by low, curved walls. In the center of the park, there are several circular and irregularly shaped garden beds with various plants and flowers. People are seen walking along the path and sitting on the grass. The overall scene is bright and sunny, with shadows cast by trees and people.

SIEMENS SMART INFRASTRUCTURE TECH REPORT

Digital Transformation, Sustainable Returns The New Pathway of Infrastructure

SIEMENS



Accelerated efforts are essential to meet our decarbonization targets and advance towards net zero. Much of this relies on the transformation of the world’s infrastructure, particularly in energy, buildings and industrial operations. The challenge is to do this at speed and at scale — without digitalization, it will be impossible.

This report explores the critical role of digitalization in accelerating sustainable outcomes, examining the links between data, technology adoption, and value creation.

It is based on new, primary research, including a survey of 650 senior executives from 13 countries and seven industries, as well as a selection of in-depth interviews with leaders and experts.

Organizations in different regions and industries are addressing decarbonization and resource efficiency at different rates and in different ways. But in all cases, we argue that digitalization is key to effective infrastructure transformation, and that there is an urgent need for increased investment in digital solutions that improve both sustainability and business performance.

KEY FINDINGS

1

Advances in digitalization enable more sustainable infrastructure — enormous potential remains

More than half (55%) of respondents say that digital technologies have significant or massive potential to advance the decarbonization of their operations. On one hand, this highlights the growing recognition that digital solutions are essential to reducing carbon footprints. On the other hand, with 45% of respondents saying they see little or no such potential, many may not fully appreciate the links between digitalization and decarbonization.

2

54% of organizations are mature or advanced in data-driven operations

Just over half of organizations rate themselves as mature or advanced in data-driven management of systems, resources, or infrastructure. Many (41%) are in early development, and 5% say they don't have any existing or planned activity. Many organizations remain in the early stages of their digitalization journeys, but those further ahead have already shown digital technologies will be central to future productivity, business resilience, and sustainability.

3

Organizations rate AI as the most impactful technology area for decarbonization and resource efficiency

Once organizations have built a solid digital foundation, they can begin to use various technologies to improve decarbonization and resource efficiency efforts. Respondents expect AI — with its ability to analyze vast datasets and optimize operations — to have the biggest positive impact on both areas over the next three years. For this to happen, more will need to be done to improve the energy efficiency of AI.

4

Data gaps pose a major challenge to decarbonization efforts

A significant proportion of respondents say they have little to none of the data they need in areas that are key to improving decarbonization and resource efficiency: 44% lack emissions data, 44% lack decentralized energy resources data, and 30% lack energy consumption data. These gaps are a critical obstacle to establishing more sustainable operations.

5

Five leading advantages of digital business platforms

Respondents highlighted five factors as the top benefits of adopting digital business platforms: scalability; time and cost efficiency; faster implementation; reliability; and interoperability. Collaboration is arguably the most underappreciated benefit.

INTRODUCTION

Harnessing Digital Solutions to Accelerate Decarbonization

It is estimated that the world needs to decarbonize twenty times faster than the current rate to limit global warming to 1.5°C above pre-industrial levels. The window for effective climate action is closing quickly.

// We are not decarbonizing fast enough. We have to ask ourselves: how can we accelerate progress and scale-up our efforts? In my view, we have to do more to harness digital technologies and collaborative innovation to build smarter infrastructure and enhance the capacity of existing systems."

THOMAS KIESSLING Chief Technology Officer,
Siemens Smart Infrastructure

In this respect, digitalization has immense potential. For example, smart grids and smart buildings use real-time data to manage electricity flows efficiently. Internet of Things (IoT) devices enhance visibility and enable integration. And artificial intelligence (AI) optimizes complex systems to boost efficiency, reduce waste, and maximize the value of existing infrastructure.

At the same time, open digital business platforms offer organizations access to continuously improving solutions and enhance collaboration with partners towards broader sustainability goals.

This research explores how organizations around the world are using digitalization to help enable decarbonization and resource efficiency efforts. We investigate which data types are most important to supporting these aims — plus whether organizations have these data types available — and how open digital business platforms are enabling much of the progress organizations are making.



This report explores

- To what extent have organizations explored the potential of digital technologies to enable decarbonization and resource efficiency?
- Do organizations have the right data to inform decision-making on their path to net zero?
- Which technologies do leaders expect to have the greatest, positive impact?



ONE

Digital investment is key to progress on sustainability



By the end of 2024, organizations around the world will have invested \$2.5 trillion in digital transformation for the year, up from \$1.9 trillion for 2022.

To put this sum in perspective, \$2.5 trillion is enough to buy one of the world's largest companies — Alphabet (Google) or Amazon, on current valuations — plus *all* of the 100 most valuable sports franchises in the world. By 2027, global spending on digitalization is expected to be close to \$4 trillion.

Many organizations have increased and maintained high levels of digital investment over the past decade, but our survey finds the majority — almost 60% — are likely to *increase* their spending on digitalization in the year ahead.

As we will see throughout this report, many organizations have realized that digitalization and sustainability are no longer separate initiatives — they are deeply intertwined.

“Achieving our decarbonization goals depends on our ability to run highly digitized, automated operations that can monitor, optimize, and reduce resource consumption in real time.”

MAGNE SETNES Chief Supply Chain Officer, Heineken





INDUSTRY SPOTLIGHT

Higher-Education

Smarter energy management can rapidly lower emissions and expenses

Higher education is one of the sectors most likely (63%) to increase investment in digital technologies in the year ahead. Many institutions have ambitious climate targets and can only achieve these by modernizing and automating the operation of campus buildings.

Southern Methodist University (SMU) in Dallas, Texas, faced challenges related to system reliability, high maintenance costs, and the need to improve energy efficiency while continuing to provide a comfortable environment for students, faculty, and staff. In response, the university implemented infrastructure upgrades, including improvements to the central utility plant, mechanical systems, and the installation of submeters and sensors for real-time monitoring. They integrated building automation, fire, safety, and security systems into a single platform and launched an energy management program featuring fault-detection and demand-flow optimization for chilled water plants.

SMU has successfully digitalized the operation of its buildings, enabling a wide range of benefits. These include energy savings of US\$9.5 million over the first five years alone, with corresponding emissions reductions, a 19% reduction in utility costs, extended equipment life, and improved system performance and reliability.

[Learn more](#)

More than half of organizations have reached an advanced level of data-driven operations

SMU's progress is not an isolated example. Many organizations have invested in digital technologies for many years, and in our survey 54% now claim to be mature or advanced in the data-driven management of systems and resources infrastructure — a key indication of overall progress in digital transformation. The remaining organizations should carefully consider the breadth and impact of the benefits of taking a digital-driven approach.



How far have organizations progressed in the development of data-driven management of systems, resources or infrastructure?

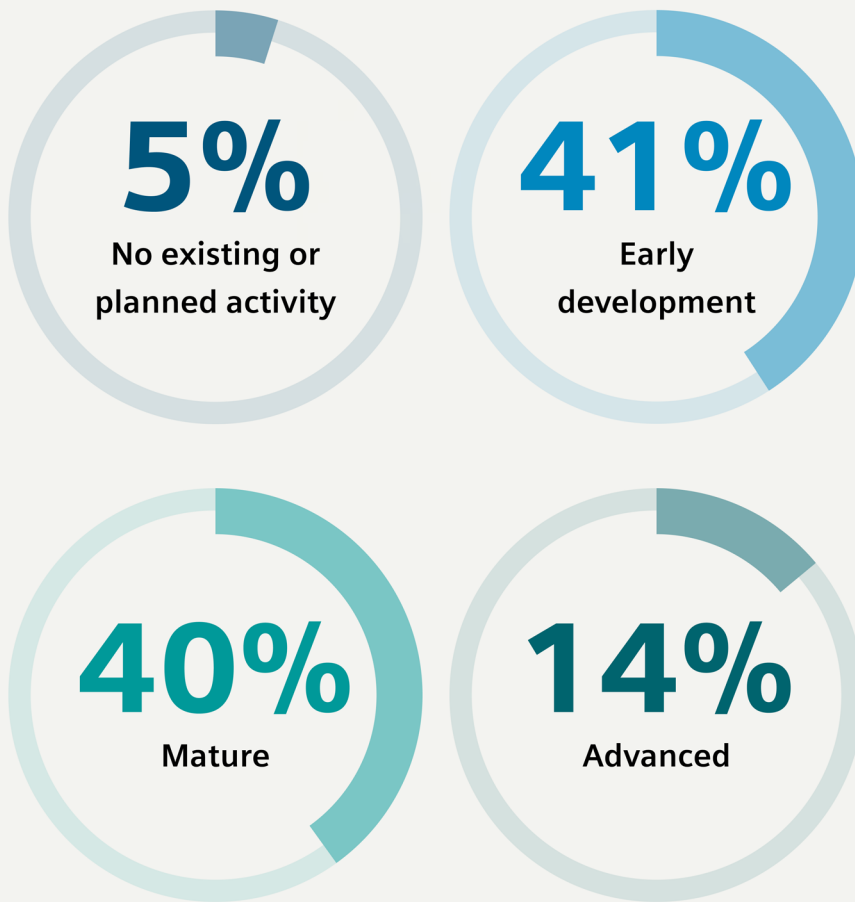



INDUSTRY SPOTLIGHT

Pharmaceuticals and life sciences

Digitally driven precision can improve processes, efficiency, and compliance

The pharmaceuticals and life sciences sector stands out for the proportion (65%) of respondents reporting mature or advanced progress in data-driven operations. Regulatory forces governing consumer protection, occupational safety, or environmental standards are a key driver of this. With regulatory authorities setting increasingly stringent rules to govern the processes, machines and buildings used to manufacture pharmaceutical products, digital precision is crucial to meeting monitoring, control, and reporting requirements.

Data-driven strategies and automated digital systems help ensure compliance, safety, quality, productivity, and efficiency. US pharmaceutical producer, Pfizer has a plant in Freiburg, Germany, which is a world-leading example of digitalization supporting multiple goals. By centralizing building control, monitoring, data analysis, and visualization, Pfizer has more than doubled productivity, to over 12 billion pills per year, while the plant now uses 40% less energy for environmental control compared with a traditional plant.

As organizations continue to allocate substantial resources toward digital technologies, the rationale for such investments becomes increasingly compelling. This is especially the case when it can be demonstrated that such investments contribute to both business and sustainability goals.

Many organizations remain in the early stages of their digitalization journeys, but those further ahead have already shown digital technologies will be central to future business resilience, sustainability and strategic growth.

[Learn more](#)

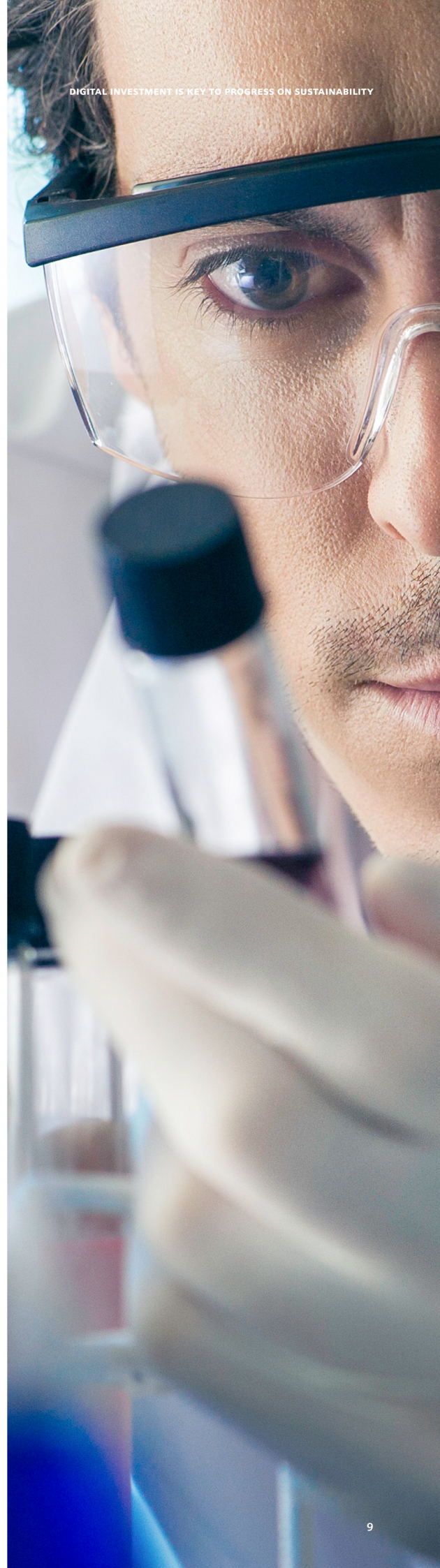

TWO

**From productivity
to decarbonization:
Digital investments
yield multiple gains**



Our survey asked respondents to rate the potential of digital technologies to advance progress across various areas of their organizations. This allows us to see how areas related to sustainability compare with those related to business performance.

Respondents rated productivity as the area with the greatest potential to benefit from digital technologies, followed by energy efficiency.

“The potential for digital tools to enhance both productivity and energy efficiency is vast. When companies gain access to granular data – whether it’s on energy use, system performance, or environmental conditions – they can make smarter, faster decisions. It’s not just about saving energy, it’s about redesigning processes to be leaner and more effective, boosting productivity and energy efficiency at the same time.”

THOMAS KIESSLING Chief Technology Officer, Siemens Smart Infrastructure

Both productivity and energy efficiency benefit from several existing digital solutions. Tools like data analytics, IoT-enabled devices, intelligent automation, digital business platforms, and AI are streamlining workflows, reducing downtime, and enabling more informed decision-making, all of which can enhance productivity and energy efficiency. In addition, these technologies, when turned towards these top two areas, will often also reduce costs.





How do you rate the potential of digital technologies to advance progress within the following areas of your organization?

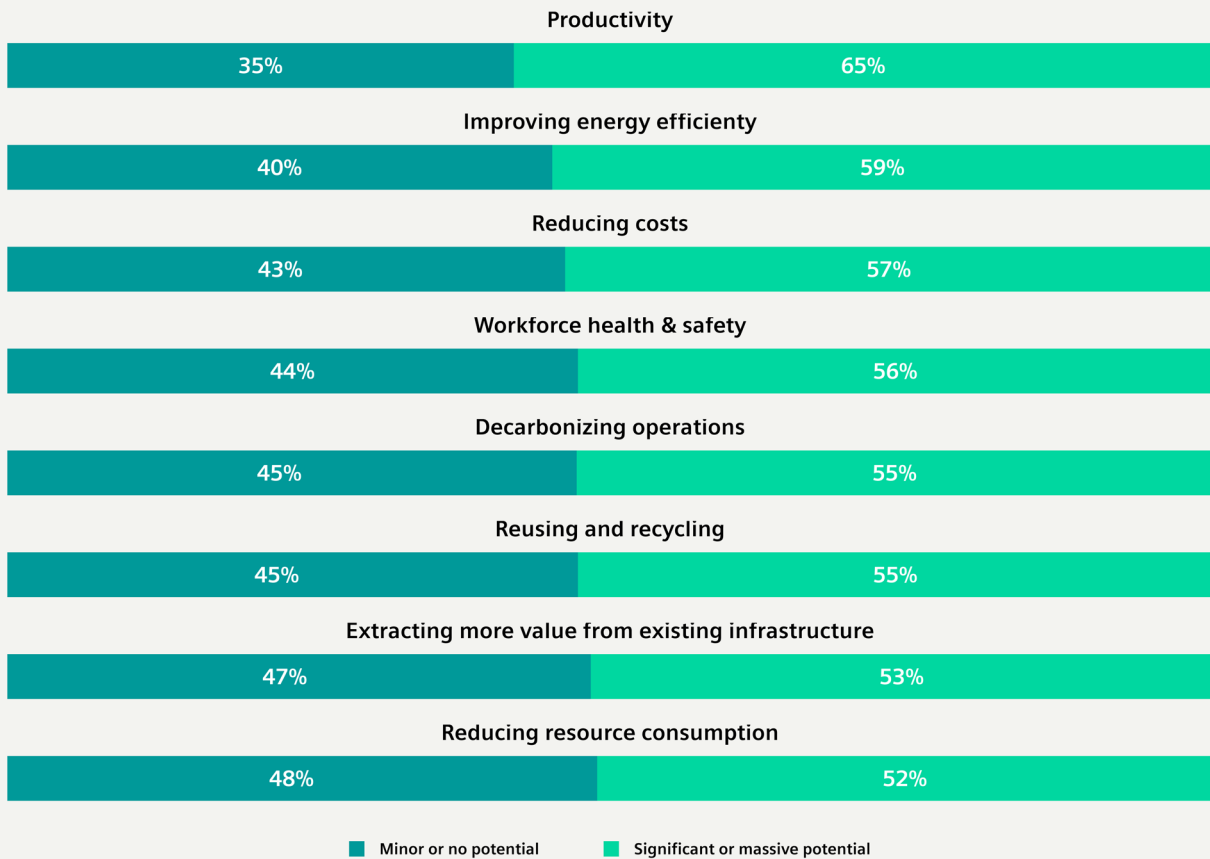

Many organizations have yet to discover the full potential of digital technologies

Across categories, a substantial proportion (over 40% in every category except productivity) see minor or no potential to accelerate progress through digital technologies. In some industries, this may reflect a lack of awareness of the potential, and in other more conservative industries, like energy utilities, this can reflect an earlier stage of digitalization. Either way, our findings suggest that while awareness is high — and many have a sense of urgency around accelerating progress — there is still significant scope to turn this into action and get more organizations to advance their digitalization efforts.



Sustainability and digitalization are inseparable. The path towards sustainability is fundamentally data-driven, and it starts with digitizing the infrastructure and the technology that runs it.

CIARAN FLANAGAN Head of Data Centers Solutions, Siemens



INDUSTRY SPOTLIGHT

Power Utilities sector

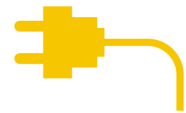

The power of visibility

The power utilities sector sees particularly strong potential to use digitalization to decarbonize, with 66% reporting significant or massive potential.

One reason for this is that grid operators can use digitalization to increase dramatically the visibility of asset performance and energy flows. This is especially the case in low-voltage grids, where many power utilities currently have low grid visibility. More advanced meters, sensors, AI-driven analytics, and digital twins can help to optimize energy flows in real time, boosting efficiency and supporting the integration of renewable energy sources and prosumers. It can also support smarter grid and flexibility management to reduce energy consumption and emissions.



Norway has the world's highest penetration of heat pumps and electric vehicles (EVs), as well as widely distributed energy resources and prosumers (industrial/commercial entities, or resident individuals, who both generate and consume energy). Under these conditions, the grid has become much more complex, volatile, and unpredictable.

Elvia, the country's largest power-grid operator, has transformed the operation of its low-voltage grid by feeding various data sources into its intelligent software.

Using a digital twin of its low-voltage grid, integrating previously disconnected data sources to provide reliable real-time insights and transparency for multiple departments. Elvia is now able to make more precise investment decisions and squeeze more grid capacity out of the existing infrastructure. The company is also much more efficient. Greater awareness has increased the flexibility, automation, and reliability of the grid, leading to a 30% reduction in outage times.

[Learn more](#)



The next generation of digital investments

Well-established digital technologies are just as important as cutting-edge innovations. Both play a role in the advancement of business and sustainability goals.

In some regions, more established technologies now include standard IoT devices, such as presence detectors, intelligent valves, or smart thermostats, as well as smart grids with advanced metering, sensors, automated switches, and integrated communications. IoT devices in industrial and residential settings enable real-time monitoring and control of machines, appliances, lighting and other equipment, significantly improving efficiency. Grid software can help to optimize electricity distribution and demand management, cutting losses, while increasing flexibility and capacity.

These areas continue to evolve and advance, while offering a digital foundation, supporting steady advances in energy management and efficiency.



The basic building block of digitalization is the fabric of interconnected devices – everything from sophisticated coding systems to simple actuators, all communicating together.”

CIARAN FLANAGAN Head of Data Centers Solutions. Siemens

Interconnected foundations support more advanced technologies

Newer digital technologies such as AI and digital twins can be built on these foundations to unlock a new wave of transformative capabilities. AI can help to predict energy demand and optimize supply, allowing for more intelligent automation and helping to harness greater value from vast, complex data sets.

Digital twins allow organizations to plan the development and management of their infrastructure through simulations in the digital world before implementation in the physical world — a capability that not only saves time and money but also helps to develop leaner, cleaner and greener infrastructure.

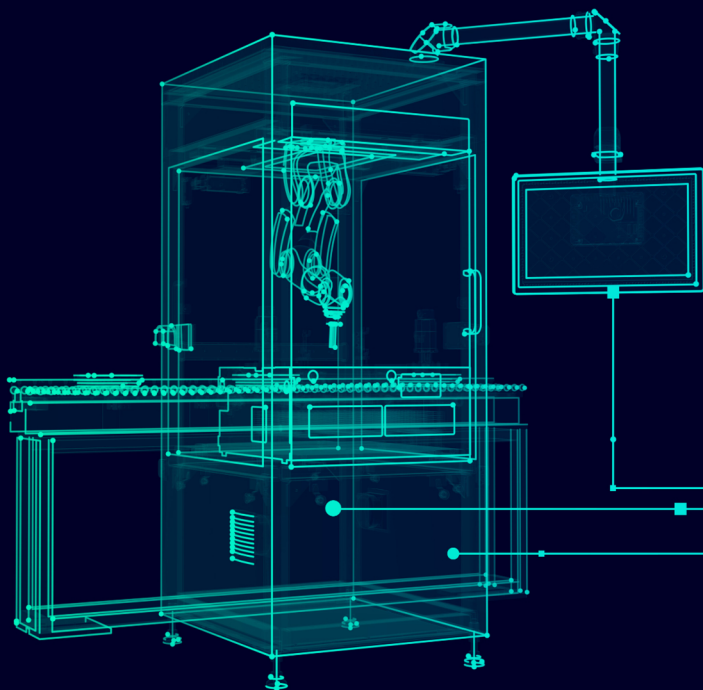



INDUSTRY SPOTLIGHT

Healthcare

Optimizing buildings before a brick is laid



Insel Gruppe AG, a major Switzerland-based healthcare provider, used live data from its existing main building to develop a digital twin of a new hospital to optimize building operations and maintenance.

This enabled a digital design including construction data that serves as a single source of truth. It helped to understand the complex interplay between various design choices and the many processes, dependencies and goals of the new hospital.

The digital twin relied on earlier digitalization efforts across the business.

// We've made a huge leap forward in integrating digital solutions into our real estate operations and core systems, enhancing our data platform. This is an important area for our industry as it is fundamental to both optimizing performance and improving sustainable operations."

ABEL MÜLLER-HÜBENTHAL Director of Real Estate and Operations, Insel Gruppe AG



With their newest hospital now complete, the business keeps progressing, repurposing the digital twin from the planning phase to support the new building management system.

// We're among the first in our sector to transfer data successfully from our digital twin to our operations system, and we continue to build on this."

ABEL MÜLLER-HÜBENTHAL Director of Real Estate and Operations, Insel Gruppe AG

AI is pushing the boundaries – but we must carefully manage its energy demands

So, which digital technologies could make the biggest positive impact on decarbonization and resource efficiency over the next three years? According to our survey: AI. While the recent rise of generative AI has brought the technology into the spotlight, it is part of a much longer-running trend that has already produced powerful results.



Digital technologies set to have the biggest positive impact on decarbonization and resource efficiency over the next three years

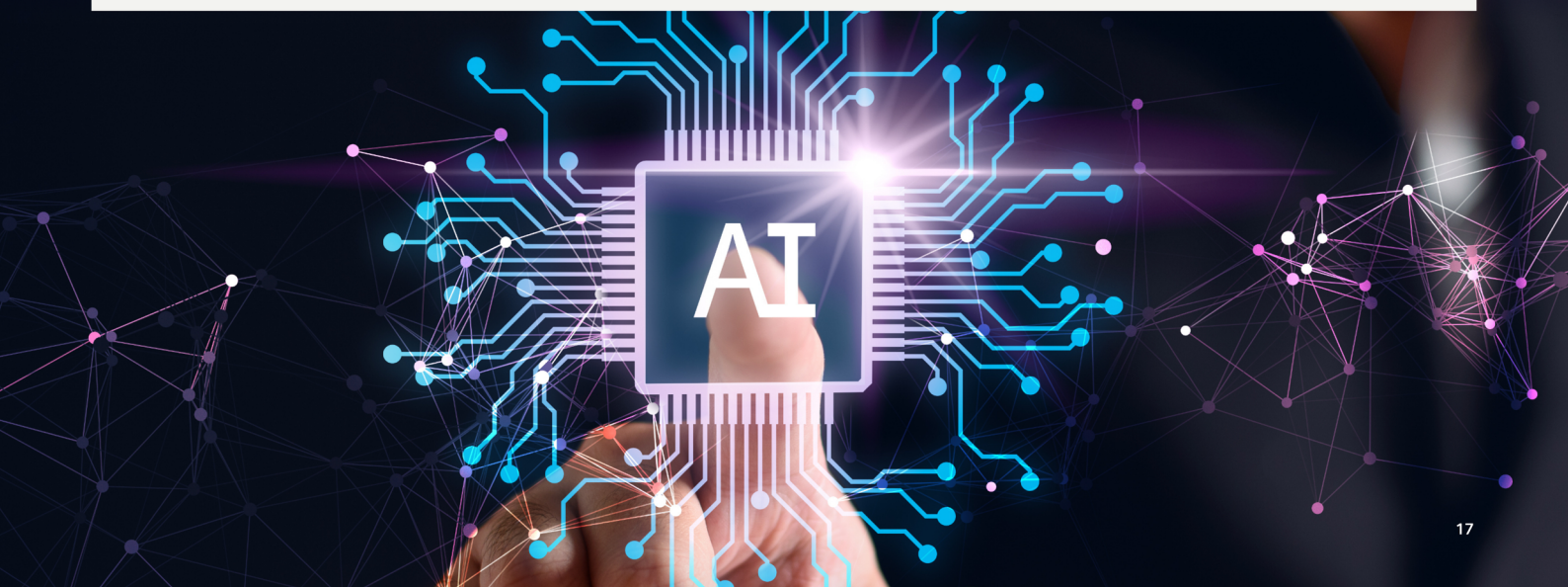
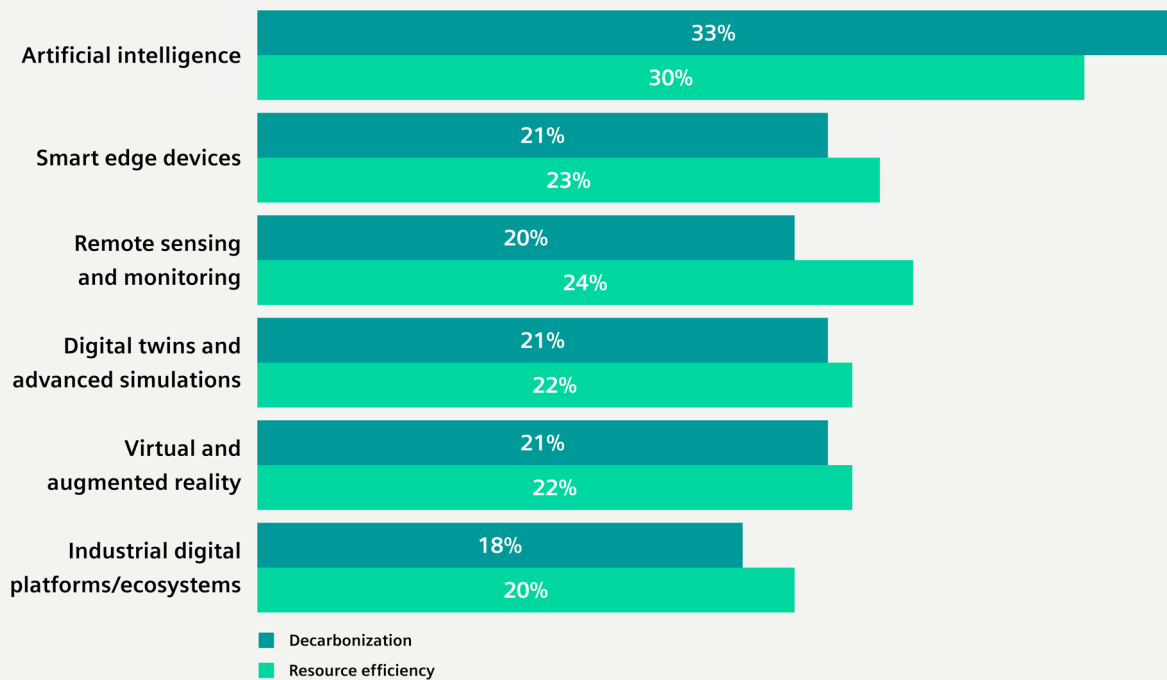

“Machine learning is already widespread in our operations, automating many processes that used to require extensive manual tuning. With more advanced AI, we’re just beginning to explore its potential, particularly in contextualizing data and predicting things like machine breakdowns or over-consumption of resources. The exciting part is how fast these technologies are evolving and how quickly they’re becoming integrated into daily operations.”

MAGNE SETNES Chief Supply Chain Officer, Heineken

For example, in just about any building, owners and managers can use cloud-based, AI-enabled management systems to monitor and control energy consumption, reducing their CO2 footprints and lowering energy costs, while ensuring compliance.

The applications for building-management AI are growing more sophisticated all the time, particularly for organizations with onsite renewable energy generation and storage. Their building management software draws on thousands of data points, generated by systems, equipment, components, occupants, or even external factors such as weather or national grid stability.

Organizations such as New York’s Javits Center, one of the busiest convention centers in the USA, are able to provide demand response services to the power grids that surround them. This improves grid stability and flexibility, while supporting the integration of variable renewable energy sources. The local authorities compensate participating businesses, lowering their operational costs. Demand response initiatives also encourage energy-efficient practices, contributing to a more sustainable and resilient energy system.

“Decarbonizing buildings is an achievable goal, with solutions readily available. IoT technology is reducing the costs of smart building technologies, enabling us to integrate systems, minimize energy consumption, and realize substantial savings. Simple upgrades, such as occupancy-based controls, peak load management, and lighting retrofits, represent more than 80% of the potential energy savings. Moreover, with HVAC systems typically accounting for more than 50% of a building’s energy use, updating these with smart, efficient technologies can significantly reduce emissions.”

THOMAS KIESSLING Chief Technology Officer, Siemens Smart Infrastructure

[Learn more](#)



THREE

Harnessing data to support both business and sustainability goals





It is estimated that there will be 38.8 billion IoT connections globally by 2029. That is more than twice the number today, implying an expected compound annual growth rate of 16% per year.

This growth is dramatically expanding the volume of data that industries have at their disposal. Industrial IoT connections are one of the ways that organizations are developing the data sources they need to become more sustainable, either directly or by supporting the use of newer digital technologies.

In the decarbonization landscape, digital technologies like AI and digital twins are powerful tools for optimizing the efficiency and performance of operations, but they rely heavily on the availability and quality of data. Without robust data, their potential remains limited.

THOMAS KIESSLING Chief Technology Officer,
Siemens Smart Infrastructure

We asked senior executives which kinds of data are most important to improve decarbonization and resource efficiency, and whether they have access to them in a form that is accurate, complete, consistent, timely, valid, and precise enough to accelerate progress.

The most important data types for advancing progress towards sustainability goals

Our survey finds that energy consumption data and customer/user behavior data are most important for advancing progress in decarbonization and resource efficiency. This is not surprising, because both have multiple uses and are important across all the industries we surveyed. Accordingly, a strong majority of respondents said that they have most, or all, of the data they need in these two areas: 70% for energy consumption data and 64% for customer/user behavior data.

// We are currently focused on setting up a digital energy management and monitoring platform. Without clear data on energy consumption, it's impossible to manage or reduce it effectively."

ABEL MÜLLER-HÜBENTHAL Director of Real Estate and Operations,
Insel Gruppe AG

But only a small minority (31% for energy consumption data, 28% for customer/user behavior data) say they have *all* the data they need. Again, highlighting the scope for improvement, around one-third of respondents say they have little or none of the data they need from these areas to advance decarbonization and resource efficiency - 30% of energy consumption data and 36% for consumer behavior data.

Often organizations have the data they need in some form, but it is not available for use because they lack the capabilities needed to integrate, manage and analyze data from various sources. Newer technologies can help to address this. Industrial IoT is increasingly wireless, supporting ease of installation and flexibility in use cases. This, and the adoption of digital business platforms, which we explore in the next section, could help more organizations increase the volume, quality, availability and value of their data.





Data type importance by availability
 (both in the context of improving decarbonization and resource efficiency in operations)

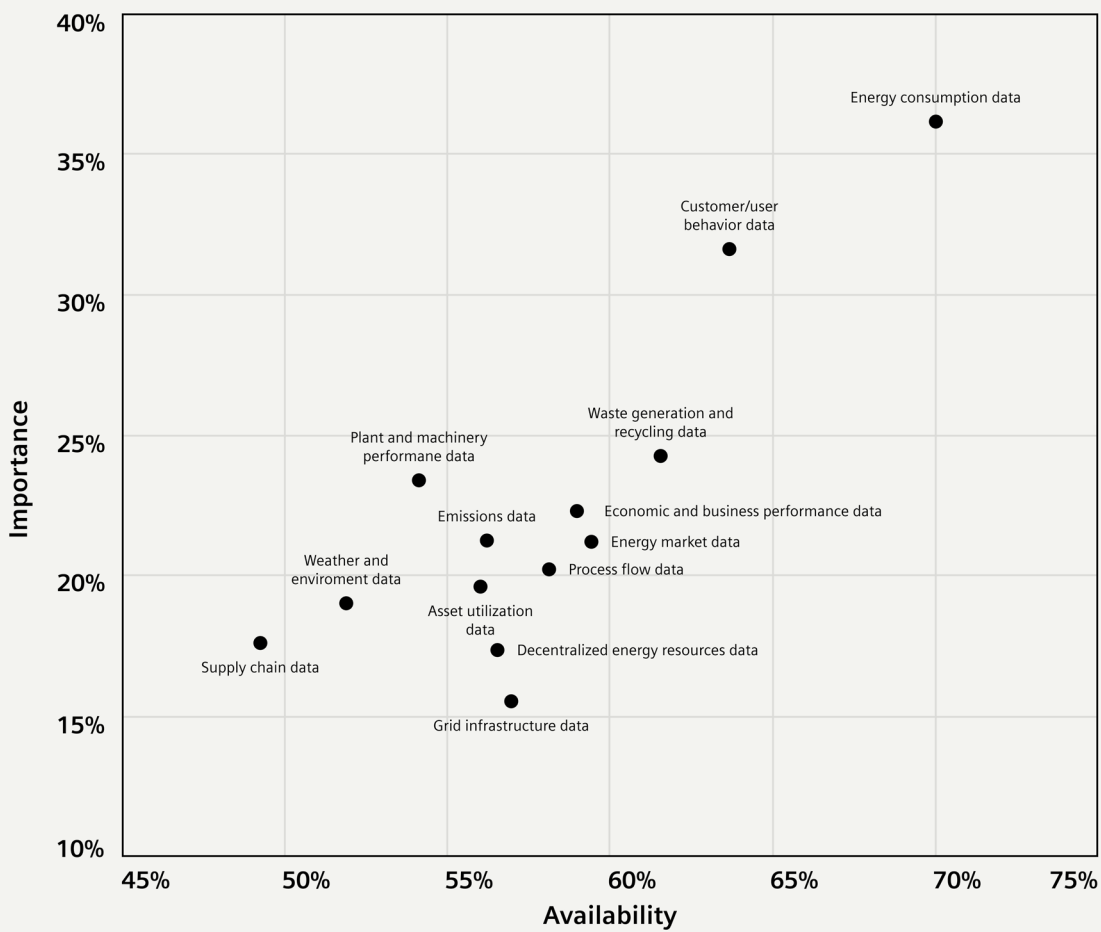

Having the right data is central to the ongoing improvement in the efficiency of energy use and electrical distribution. Every Watt matters: even the smallest improvements in energy efficiency can have a significant impact across large-scale operations. Organizations increasingly rely on data from interconnected digital systems to identify and seize these opportunities."

CIARAN FLANAGAN Head of Data Centers Solutions, Siemens



INDUSTRY SPOTLIGHT

Food & beverage

Real-time data transforms organizations

Many organizations have been transformed by developing, improving and expanding the data available to them.

// *In the past, we operated in silos. Data would come in from the breweries once a month, and we would publish reports and recommendations from the center. It was a slow, reactive process. We now have real-time data streaming from every operation, allowing us to make decisions instantly. This shift has been revolutionary. We no longer wait for monthly reports; we can optimize performance on the fly, continuously adjusting and improving to ensure that we're running as efficiently and sustainably as possible."*

MAGNE SETNES Chief Supply Chain Officer, Heineken

An improved data framework unlocks further opportunities. Heineken were able to use a digital twin of a typical brewery to precisely track energy consumption patterns and determine where they could make the biggest efficiency savings. This led to greater optimization of thermal systems and the discovery of a major opportunity: implemented broadly, the measures will help to halve carbon emissions and support energy savings of up to 20%.

[Learn more](#)



Decarbonization and resource efficiency rely on several key data types

Improving certain data types is a matter of urgency. For example, respondents rate emissions data as highly important, but 44% of organizations say they have little or no access to the emissions data required to improve decarbonization and resource efficiency.

“When it comes to decarbonization, having real-time insights into your emissions and energy use is just the first step, the real power lies in understanding what’s driving those emissions at a granular level—right down to individual machines.”

MAGNE SETNES Chief Supply Chain Officer, Heineken

Data from decentralized energy resources (e.g., wind, solar, storage) is also crucial, especially as these take a larger portion of the global energy mix. Power utilities in our survey rate this data as the second-most important to decarbonization and resource efficiency (after energy consumption data), but only 24% from that industry say they have all the data they need in this area. Having the right data improves simulations and forecasts in key areas such as renewable energy generation and consumption patterns.

“One of the biggest data gaps we face is from distributed energy resources (DERs). We’re trying to determine which data we need, but we’re also aware that there’s data we might not even know we need yet. This presents a real challenge for strategic planning in an industry that’s changing so rapidly.”

EVAN O’MAHONEY Chief Information Officer, CPS Energy

FOUR

Digital platforms combine the real and the digital worlds



Open digital business platforms and ecosystems offer organizations a powerful way of creating more value from digitalization. They allow for the integration of devices, software and digital services, meaning a diverse group of stakeholders, including customers, partners, and developers, can contribute to organizational innovation.

The best open digital business platforms offer a curated, modular suite of information and operational technologies (IT/OT), built on standardized application programming interfaces (APIs). They are highly interoperable, seamlessly exchanging data and functionality between new and legacy systems, and between different hardware and software providers. This interoperability empowers businesses to develop, adapt and scale their digital infrastructure rapidly and according to their specific needs.

// A decade ago, you would buy a control system and vendors would ship physical hardware with pre-installed applications. The business would then manage the system for several years, before upgrading to a new version and repeating the cycle. Today, we have a modular platform that allows more flexibility, scalability, and continuous updates, aligning with modern, cloud-enabled practices and reducing dependency on hardware refresh cycles.

EVAN O'MAHONEY Chief Information Officer, CPS Energy

A major strength of open digital platforms is that they provide access to ecosystems of solution vendors, technology partners and other users. Collaborative teams develop, test, iterate and improve applications and modules within the ecosystem, accelerating transformation at lower cost.



Digital business platforms bring scale at a lower cost

Our survey asked respondents to select the biggest benefits of digital platforms. Industries differed in important ways on this question. Respondents from power utilities, for example, say that the biggest benefit is that platforms are adaptable to new requirements. Utilities face major challenges adapting to fast-paced changes, uncertainty, and complexity, particularly in integrating diverse decentralized energy resources like intermittent renewables and prosumers. Accelerated investments in smart grid technologies and digital transformation are critical for managing these complexities, but also mean they are continuously adapting.

Looking across all industries, the overall average shows a cluster of five topped the list overall:



For many organizations, such a powerful combination has proven transformative.

“Open digital business platforms enable organizations to transition from manual processes to advanced digital operations. Many of our customers are still at the early stages of their digitalization journeys, with equipment that’s not yet connected or ‘smart.’ Our Siemens Xcelerator platform provides the framework for transforming these operations, built on a foundation of interconnected systems and devices.”

CIARAN FLANAGAN Head of Data Centers Solutions, Siemens



The biggest benefits of digital business platforms:

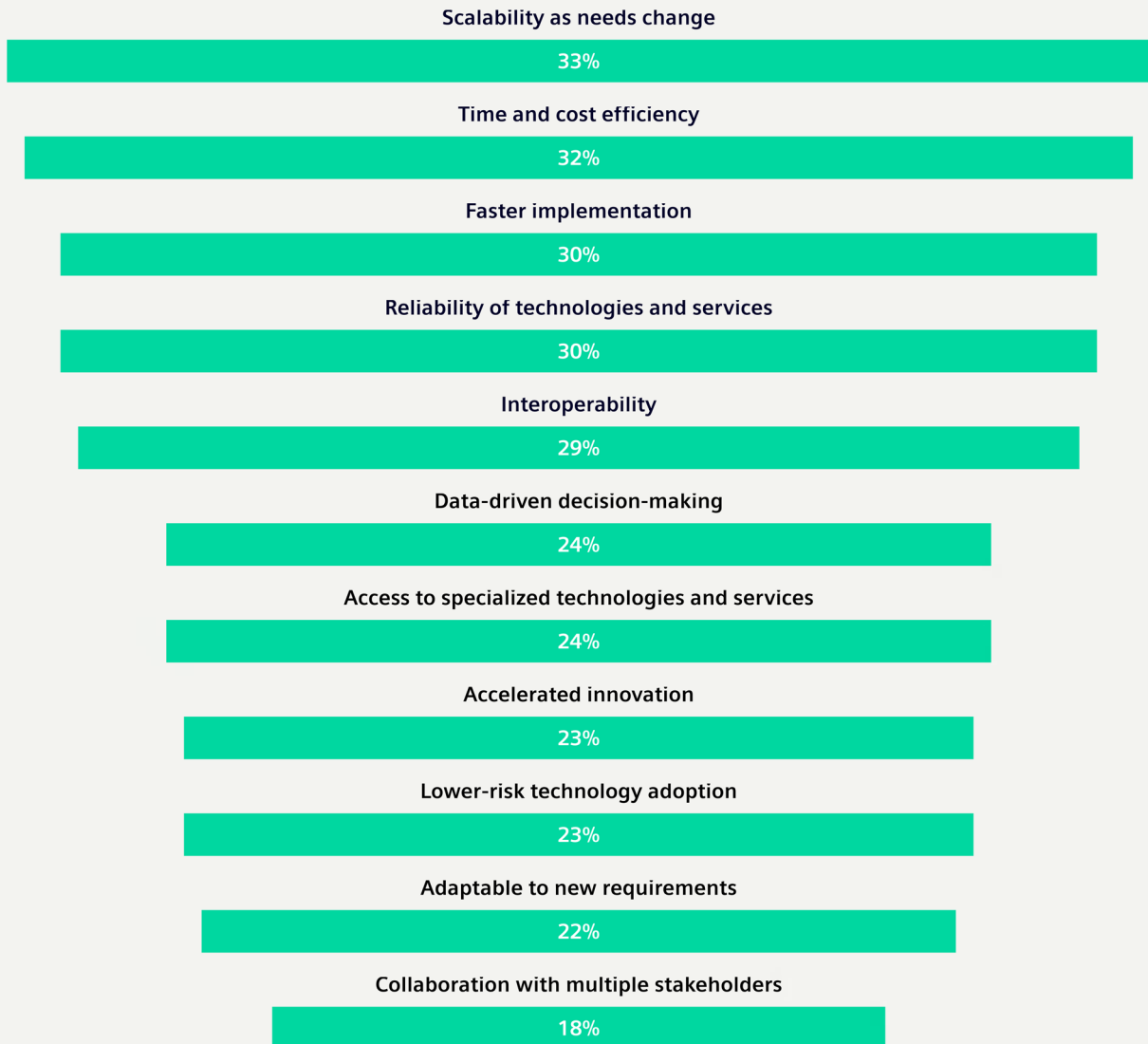

The interoperability of open digital business platforms is an essential feature because it enables productive collaboration and exchange on many levels — between partners, peers, and providers, as well as between different digital systems.

This unifying nature of open digital business platforms has helped many organizations to integrate data from disparate systems.

A major benefit of consolidating all our control systems onto a single platform is that it simplifies the integration of data models from various areas, particularly bringing together generation management systems and distribution management systems. The aggregation of data flows helps us provide the right information at the right time, so our team can make the right decisions, whether that is isolating the grid to minimize the impact of an outage or understanding what the day-ahead market looks like, inclusive of distributed energy resources.”

EVAN O'MAHONEY Chief Information Officer, CPS Energy

Collaboration is an underappreciated benefit

While collaboration with multiple stakeholders was the lowest ranked benefit, there are still many organizations that have found great value in this aspect. At Heineken, for example, it has helped the business work seamlessly with specialist partners that are helping them to improve performance and sustainability.

In the past, suppliers or engineering firms would only have access to fragmented or limited data. Now, with our connected brewery platform, we can securely share data with our partners, giving them the insights they need to help us improve performance and sustainability. This is a win-win situation — our suppliers can use the data to refine their own processes and equipment, while we benefit from their improvements. It's a much more collaborative and efficient way of working.”

MAGNE SETNES Chief Supply Chain Officer, Heineken

Decarbonization takes collaboration between organizations, particularly Scope 3 emissions, which come from supply chains and partners. Open digital business platforms can play a crucial role here, potentially helping industries develop greater transparency and standardization in emissions reporting.



INDUSTRY SPOTLIGHT

Data centers

Growing capacity while optimizing efficiency

Over the next eight years, the data center industry is expected to grow at over 10% annually. The AI boom has put pressure on the industry to expand as quickly as possible, so it is unsurprising that those in the industry view scalability and fast implementation (of software and hardware) as the biggest benefits of digital business platforms.

The promise of digitalization for data centers revolves around efficiency and reliability. With digital platforms and better real-time data, operators can make informed decisions, ensuring that every part of the network runs reliably at optimal efficiency. At the core of digital transformation is the ability to tackle complexity, improve asset visibility, and engage in proactive capacity planning. All of this enables the efficient use of resources."

CIARAN FLANAGAN Head of Data Centers Solutions, Siemens

The biggest challenge is to maintain swift growth while meeting sustainability goals. Data centers are expected to consume 8% of global electricity by 2030 – up from about 1.5% today. This makes sourcing power a top priority for data centers around the world. Much of the power data centers use is for cooling, so greater efficiency in this area can make a massive difference to costs, emissions, and scalability.

Greenergy Data Centers in Estonia is good case in point. It leverages efficient, renewable energy sources, and technology for optimal cooling management. Beyond benefitting from the region's cold climate for free cooling, they also have adopted an AI-enabled technology that adjusts cooling dynamically based on real-time data from thousands of sensors, which monitor temperature and airflow every second of every day. This creates an enormous amount of data, which can in turn create enormous value. Greenergy harnessed this data across their operational platforms to help their new facility target a power usage effectiveness (PUE) below 1.2. To put this in perspective, the industry average is about 1.6, while a PUE of 1.0 is an almost unattainable ideal, where all the energy used by the data center is used directly for computing, with no energy wasted on cooling, lighting, or other support systems.

[Learn more](#)



Obstacles should not halt progress

Adopting digital business platforms is not without challenges. In our survey, respondents chose complexity and the cost of implementation as the leading barriers. However, they also recognize time and cost efficiency as leading benefits of adoption, which decision-makers should consider as offsetting factors.



The biggest barriers to adopting digital business platforms: cost and complexity top the list

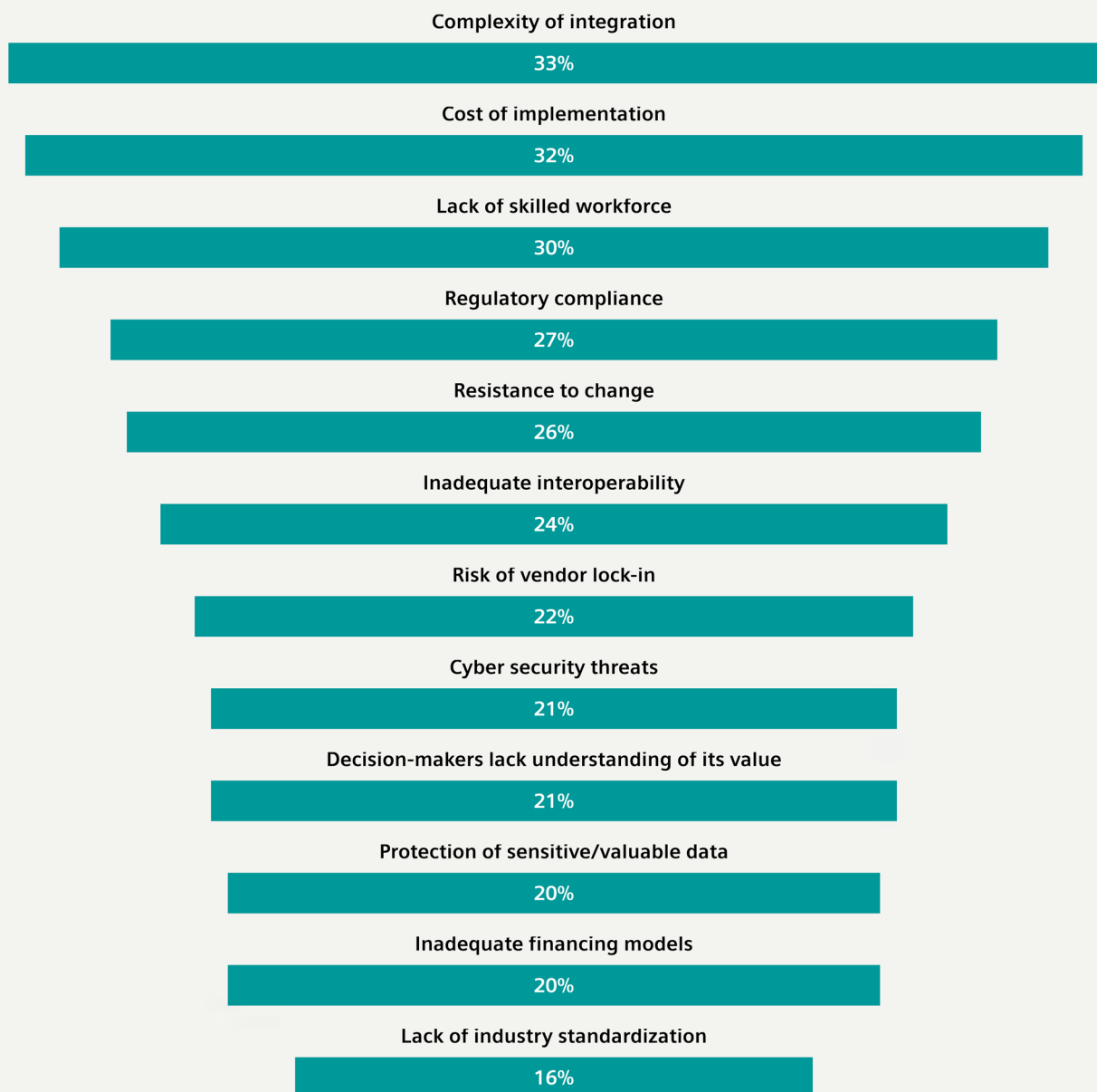



Regulatory compliance can also slow adoption in some industries but, as with the other barriers to digital business platforms, innovation and strong, practical leadership can overcome this.

“One of the biggest challenges in transitioning to open digital platforms is managing compliance and security without hindering data access. We're building architecture and creative solutions to strike that balance, including using AI and machine learning to aggregate data and generate insights without compromising access controls.”

EVAN O'MAHONEY Chief Information Officer,
CPS Energy

“There's expertise in different parts of every industry, many areas of specialist knowledge, new innovations — no organization or technology provider can do it alone. Collaboration, openness, and partnership are essential if we're going to accelerate the energy transition and build more sustainable industries

CIARAN FLANAGAN Head of Data Centers
Solutions, Siemens

If digitalization champions are able to demonstrate the leading benefits (scalability, efficiency, speed, reliability, adaptability, etc.) and risk-mitigation measures, they should be able to convince both the regulators and change-resistant colleagues that it's worth it. All the barriers to digital business platforms are surmountable, and all are compensated for by the depth and breadth of the benefits of adoption.

CONCLUSION

Digitalization scales positive impact faster

Digital technologies are supporting and enabling sustainability efforts to shape the future of businesses. Digital tools enhance organizations' ability to use data, AI, and automation to reduce carbon emissions and drive efficiency. But the path to a greener future isn't without its potholes.

One major issue is the lack of reliable data, especially on emissions and distributed renewable energy sources, making it hard to take informed decisions and track progress. If they are to achieve their sustainability targets, organizations need to close these gaps.

But new solutions are arriving all the time. Many believe AI will help companies cut emissions significantly over the next few years (even though it also increases demand for electricity). AI can analyze data, optimizing energy use, and reducing energy losses — but it can also be a powerful tool for addressing the data gaps that many companies face today.

This future is not just about scaling technologies; it's about scaling impact. As our introduction explained, the world needs to decarbonize at seven times the current rate to meet global climate targets. Successful digital transformation holds the key to accelerating that progress. Organizations must move beyond incremental improvements and embrace a collaborative, data-driven approach that fully integrates digitalization and sustainability into their operations.

This future is not just about scaling technologies; it's about scaling impact. As our introduction explained, the world needs to decarbonize at seven times the current rate to meet global climate targets. Successful digital transformation holds the key to accelerating that progress. Organizations must move beyond incremental improvements and embrace a collaborative, data-driven approach that fully integrates digitalization and sustainability into their operations.



Contact us if you would like more information about this research, including results by industry or region.

ABOUT THE RESEARCH

A survey of 650 senior executives underpins this research, as well as a selection of in-depth interviews with leaders and experts.

The survey respondents represent 13 countries and seven industries, listed below. Most work for private-sector businesses (64%), with 29% from public-sector services or infrastructure, and the remainder from hybrid public-private services or infrastructure organizations.

Respondents are from organizations of all sizes, unified by having a significant influence over the future development and/or operation of infrastructure assets (including owners, investors, designers, builders, consultants, operators, occupants, or specialist service providers).

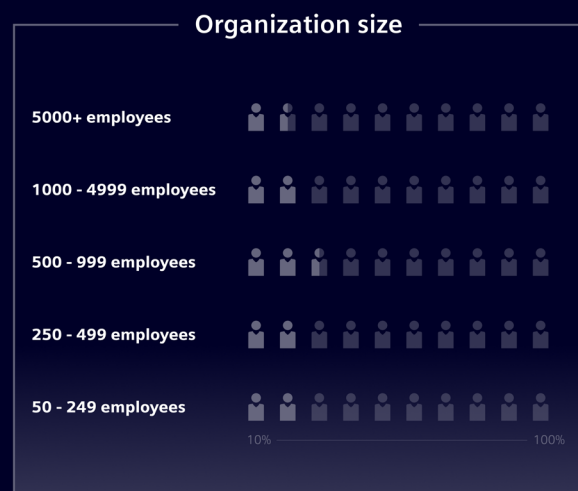
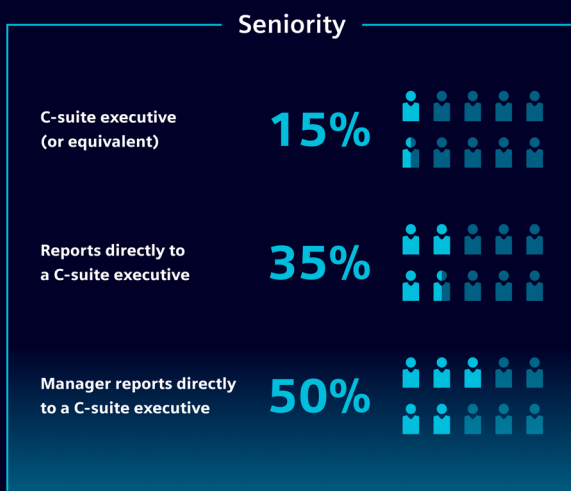

ACKNOWLEDGMENT

We would like to thank the following for contributing their time and insights to this research

CIARAN FLANAGAN

Head of Data Centers Solution
Siemens

THOMAS KIESSLING

Chief Technology Officer
Siemens Smart Infrastructure

ABEL MÜLLER-HÜBENTHAL

Director of Real Estate and Operations
Insel Gruppe AG

EVAN O'MAHONEY

Chief Information Officer
CPS Energy

MAGNE SETNES

Chief Supply Chain Officer
Heineken



Published by

Siemens Switzerland Ltd.

Smart Infrastructure

Global Headquarters

Theilerstrasse 1a

6300 Zug

Switzerland

Tel +41 58 724 24 24

**For the U.S. published by
Siemens Industry Inc.**

3617 Parkway Lane

Peachtree Corners, GA 30092

United States

Subject to changes and errors. The information given in this document only contains general descriptions and/or performance features which may not always specifically reflect those described, or which may undergo modification in the course of further development of the products. The requested performance features are binding only when they are expressly agreed upon in the concluded contract.

We create technology to transform the everyday, for everyone. Our world is changing at an unprecedented rate. Demographic change, urbanization, glocalization, environmental change, resource efficiency, and digitalization are presenting new challenges and opportunities.

Siemens Smart Infrastructure addresses these topics by combining the real and the digital worlds.

Our technology transforms infrastructure, across buildings, electrification, and grids, at speed and scale, enabling collaborative ecosystems to accelerate our customers' digital journey to become more competitive, more resilient, and more sustainable.

[siemens.com/smart-infrastructure](https://www.siemens.com/smart-infrastructure)