

**SIEMENS**

*Ingenuity for life*



We make your  
building more  
efficient & safer

Intelligent systems, solutions and  
products at a glance.

[siemens.com/buildingtechnologies](http://siemens.com/buildingtechnologies)



# Total Building Solutions creates added value for a building - due to added comfort, protection, security and energy efficiency

If you know that 80% of the total building costs only arise during the operation, it becomes clear how important it is to understand building technology as a holistic discipline.



«Urbanisation» – The challenge of networking

Warmth and a safe roof over your head stopped being enough for a long time: The requirements for modern buildings are steadily increasing. So it is important to plan today's buildings for the future, in a way that they should also meet the requirements of the future.

Buildings must therefore grow along with the requirements and be integrated into a complex network of different building types. Also, pressure increases in many respects: Resources are becoming increasingly scarce, regulatory

requirements and security requirements on the other hand are steadily increasing. This also increases the cost pressure. There are numerous reasons therefore, to plan exactly how buildings are to be built in the future.



Today modern buildings have to accommodate a wide range of stakeholders. Building owners use reliable data to make smart decisions. Building managers must be able to supply this exact data. You must have a complete overview of the building technologies at any time, in order to be able to intervene whenever necessary. Building users, on the other hand, are interested in comfort,

protection and safety. Comfortably warm in the winter, pleasantly cool in the summer. If it is dark outside - more light, if the sun shines - less artificial light - in constant interplay with the blinds. What happens in case of an unpredictable event like a fire? The fire alarm system detects the fire and controls numerous other systems - completely automatically and in the highest possible safety.

Regardless of the scenario, the most important thing remains the smooth interaction between all required disciplines. This requires a great deal of know-how from a wide range of specializations as well as a building management system, that allows all these topics to be linked together as seamlessly as possible.

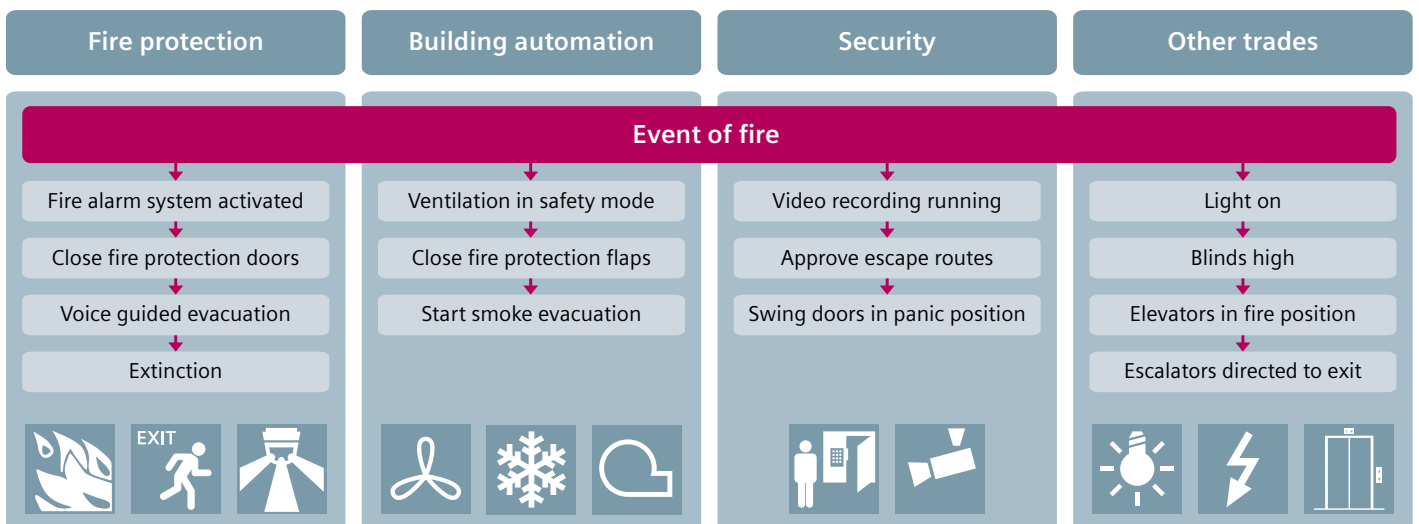

Interplay of several disciplines for the «fire» event

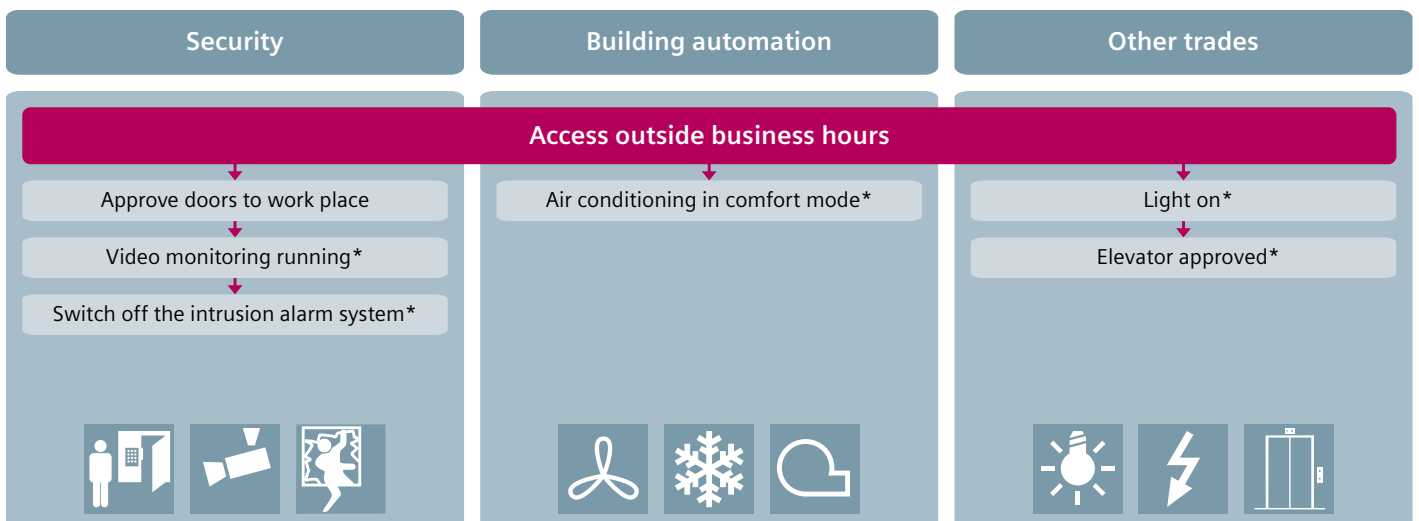

Interplay of several disciplines for the event «Access outside business hours»



# Desigo

## The Building Management Platform Desigo CC

Desigo CC controls, monitors and optimizes all the systems in a building – starting with heating, ventilation and air conditioning and also including fire protection and safety, energy management, lighting and shading. Thanks to the open standards, third-party components can also be integrated easily and completely.

Suitable for single or multiple systems

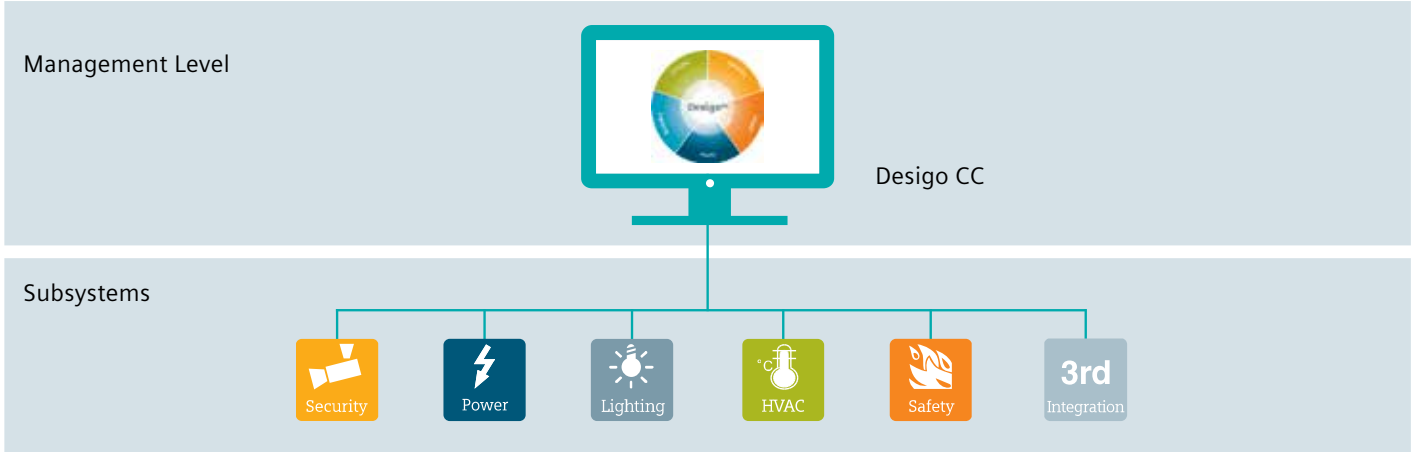

Desigo CC integrates and allows to be integrated

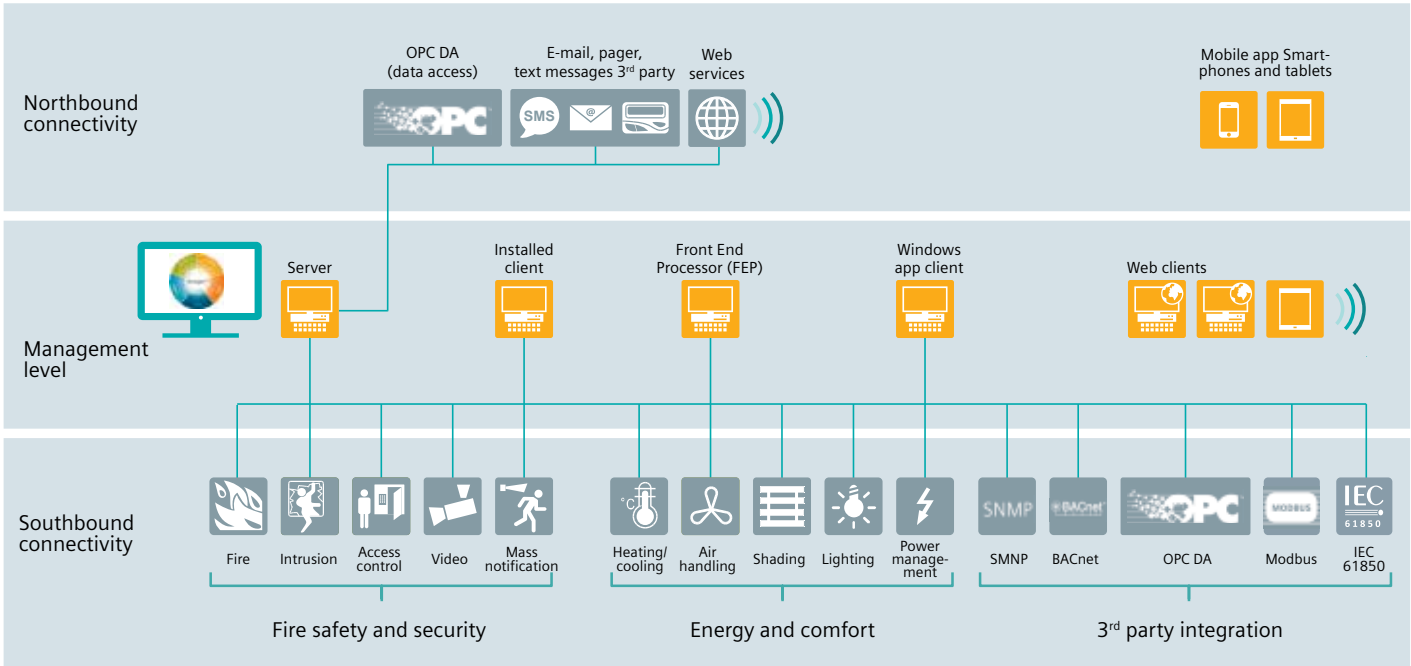



# Desigo

A building management system centrally monitors and visualizes both single and multiple disciplines. It bundles all relevant information and presents it to the operator in a simple and clear manner. A management system or the control level in the area of building automation is always actively in motion and represents the actual operating station of the system. On the other hand, a security level is static: if an alarm occurs, it must be dealt with immediately, since life or valuable assets are endangered.

## The objectives of a building management platform are:

- To visualize the states of the different systems in a building
- Unifies the different operating philosophies and operating possibilities of the individual sub-plants
- Simple and intuitive presentation
- Low learning effort with changing operators
- Reduces errors in the event of an alarm by means of defined sequences and guided alarm treatment
- Operating the control and regulating functions of the systems (HVAC or access)
- Building monitoring (e.g. with video images)
- Logging the states (Status and Reporting)
- Trending and Energy Management (e.g. optimization of energy consumption)
- Alarms and escalation of alarms
- Intelligent alarm scenarios
- Scalable from small buildings or individual systems to campus solutions for many or large buildings and various disciplines

What makes a building management platform such as Desigo so unique? By combining building automation (HVAC, room automation, energy efficiency), building security (fire, intrusion, access control, video surveillance, etc.) and also the energy distribution on an integral, continuous platform, overlapping interactions can be realized. For example, in the event of a fire, in addition to the actual alarm, air flows, escape routes, lighting, image updates and power interruptions can be intelligently combined, controlled and monitored from a central, continuous platform. This includes classical functions such as extensive reporting, alarms, guided alarm handling, etc.

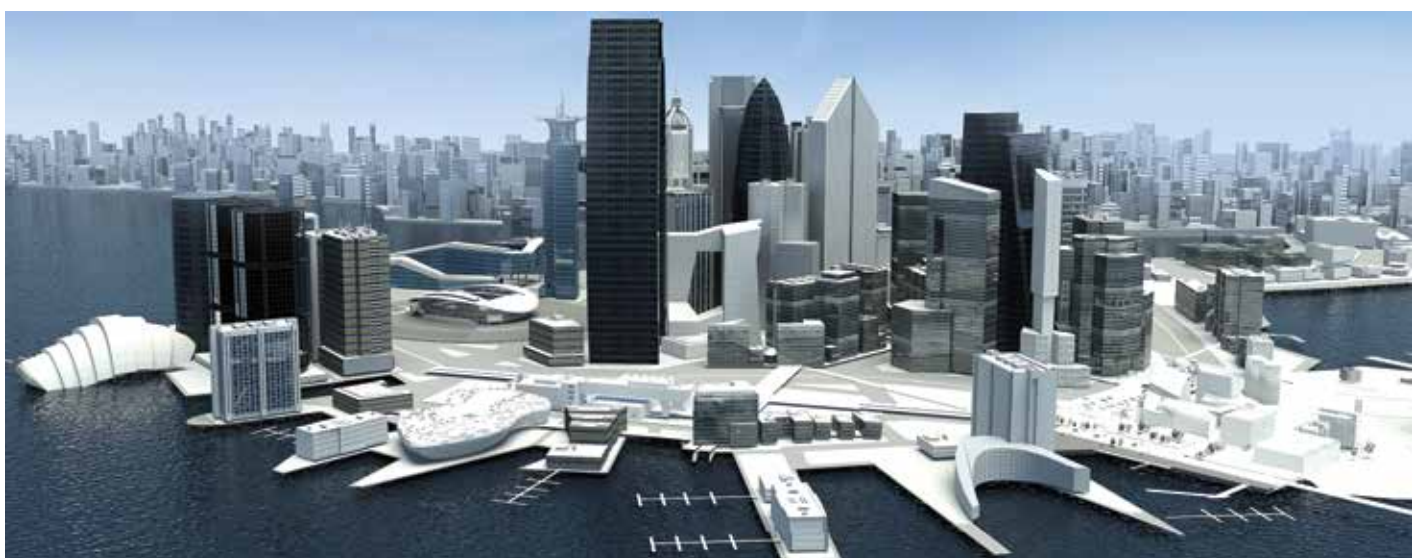

Desigo CC can be used for all types of buildings - right up to cross-building control and administration.





# Desigo – a flexible system that adapts to your needs

In building operation today, maximum flexibility has become a key argument for investors and tenants. The Desigo building management platform can easily adapt to changing requirements, offering optimized usability and comfort, and improving performance in a perfect place.



BACS efficiency classes – EN 15232		Thermal energy	Electrical energy	Efficiency factors
High energy performance BACS and TBM	<input checked="" type="checkbox"/> <b>A</b>	0.70	0.87	
Advanced BACS and TBM	<input type="checkbox"/> <b>B</b>	0.80	0.93	
Standard BACS	<input type="checkbox"/> <b>C</b>	1.00	1.00	
Non-energy-efficient BACS	<input type="checkbox"/> <b>D</b>	1.51	1.10	

**BACS** Building Automation and Control System  
**TBM** Technical Building Management System

An intelligent building automation system creates the ideal framework for meeting the requirements for efficiency class A under European Standard EN 15232, and other similar global standards. This allows offices to save up to 30 percent thermal and up to 13 percent electrical energy compared to efficiency class C.

## 1. Building management – central and convenient

The Desigo CC integrated building management platform allows you to control and operate one or multiple disciplines like HVAC, lighting, shading, fire safety and security from one central location. Its modular, user-friendly software makes operation easy and intuitive. The Desigo Control Point embedded building management station allows easy operation and monitoring, creating perfect building conditions from anywhere.

## 2. Desigo™ Room Automation – enhanced comfort and productivity

Desigo Room Automation integrates all building disciplines – from heating, ventilation and air conditioning (HVAC) to lighting and shading. This allows you to lower your energy consumption and costs while increasing room comfort.

### Lower energy consumption

Thanks to the energy-saving functions and user targeting, the Green Leaf symbol increases energy efficiency through the energy-saving process.

### Lighting

The lighting level is automatically adjusted to match the time of day.

### Perfect shading

Blinds are optimally adjusted to allow the use of natural light, minimize glare and protect from the heat and the cold.

## 3. Plant automation – flexibly scalable

The Desigo automation stations and operator units efficiently control and monitor your building plants using a variety of energy-saving functions for energy production and distribution. Data is exchanged with room automation to make sure energy is supplied only when needed to heat, cool or ventilate a room. This allows the air volume flow to be optimized based on demand and the energy-efficient operation of your ventilation and air conditioning to be enforced. At the same time, comfort control ensures that temperature, air quality and humidity limits are not exceeded. If inefficient operation occurs, you will be notified automatically via the Green Leaf symbol on the management platform or room units.



# Desigo - Proven applications - sustainability and energy-efficiency



## Wide variety of applications for enhanced energy efficiency

Using Desigo™, heating, ventilation and air conditioning plants as well as other building systems, such as lighting and shading, can be controlled and monitored flexibly and based on demand. Intelligent applications – tested under practical conditions – prevent unnecessary energy usage. And since the Green Leaf of the operating unit indicates the plant's current state of efficiency by changing its color, room users can take action and save energy. At the Desigo CC management platform level, the Green Leaf indicator in the plant viewer allows informed decisions on how to operate your building economically and ecologically. This way, the use of innovative applications sustainably cuts building operating costs, preserves energy resources and lowers CO<sub>2</sub> emissions, thus saving money and protecting the environment.

- Added plant value due to the use of energy-saving, modern equipment
- Contribution to meeting the requirements of EN 15232 in the highest efficiency classes
- Room users save actively energy thanks to the Green Leaf
- Leveraging the energy-saving potential and support for economical and ecological building operations thanks to the Green Leaf indicator
- Sustainable reduction of energy and building operating costs



## RoomOptiControl: perfect room climate, optimized energy usage

### Use: active energy management by room users

With Desigo Room Automation (RA), the room user gets actively involved in building energy management. The RoomOptiControl energy efficiency function identifies unnecessary energy usage and indicates it on the room operating unit. When the Green Leaf's color is green, the system ensures energy-optimized operation. If the color changes to red, there is energy saving potential – for example when blinds are closed and lights are on. By pressing on the symbol, room control returns automatically to energy-optimized operation. This way, the room user is enabled to easily stop the waste of energy – with no need for expert knowledge. Important: The intelligent RoomOptiControl function ensures a comfortable room climate, good air quality, the right room temperature level and optimum lighting, even in energy-optimized operation.

- Perfect room climate for productive, healthy working environment and well-being of room users
- Up to 25 percent energy cost savings and contribution to environmental protection







# Desigo - Proven applications - sustainability and energy-efficiency

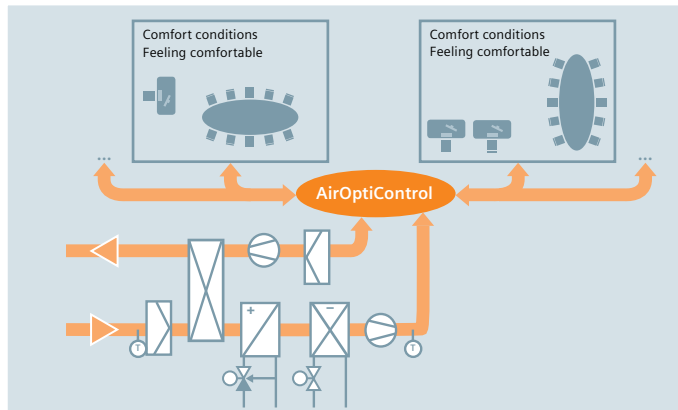

## AirOptiControl: optimized volumetric air flow saves costs

### Use: ventilation and air conditioning

AirOptiControl optimizes the volumetric air flow, thus providing an excellent basis for energy-efficient operation of ventilation and air conditioning systems. At the same time, comfort control ensures adherence to the boundaries of temperature, indoor air quality and humidity. The innovative, modular designed application offers a number of function variants for the control of air handling plants or for optimum fan operation. Demand control can be varied depending on the design of the VAV (variable air volume) controls installed in the plant. AirOptiControl is suited for individual room systems or several zones and also controls basic load heating.

- Energy costs reduced by up to 50 percent in comparison with constant pressure control systems thanks to unique energy efficiency mode for demand-based air volume control
- Full adherence to the required temperature, indoor air quality and humidity levels
- Existing plants can be upgraded while ensuring short payback times



Specific visualization options for managing and monitoring the energyefficient plant operation with Desigo CC.

## Quick and easy presentation of energy-related information

### Use: analysis and optimization of building's energy balance

With Desigo CC, energy-related information can be delivered quickly and straightforwardly. Using energy efficiency coefficients, similar types of buildings can be compared with each other. Facility managers are thus enabled to keep a close watch of total energy usage, energy costs and CO<sub>2</sub> emissions. After entering the building and energy data, a detailed analysis of the relevant building can be made while giving consideration to the number of heating degree days, if the meter readings for the same period of time (minimum 36 months) are available.

Based on historical data, the system also delivers a consumption forecast for the next 12 months, which becomes increasingly accurate as data are continually recorded. When the calculation is completed, a report can be printed.

- Comparison of energy-related data between different types of buildings
- Presenting options for cutting building costs and reducing the impact on the environment



Graphic evaluation of energy-related data on the management platform Desigo CC:

- Presentation of historical energy consumption data
- Comparison and analysis of consumption periods
- Energy usage forecast



# Building automation

Building automation means monitoring, control, regulation and optimization facilities in buildings. It therefore constitutes an important component of technical facility-management.

### Highlights

- Intelligent networking of building architecture, systems technology and room comfort
- Needs-based control of individual systems and thus reduction of energy consumption



### Basics of building automation

The aim is to carry out function sequences independently of the work group and automatically according to predetermined parameters, or to simplify their operation or monitoring. All sensors, actuators, operating elements, loads and other technical units in the building are networked with one another. Processes can be summarized in scenarios. The characteristic feature is the decentralized arrangement of the control units as well as the continuous networking by means of a communication network or bus system.

### Different areas of application

Depending on the application - whether in data centres, functional buildings or office buildings - the choice of the right systems is crucial. Optimally matched components are important. This reduces installation and operating costs while guaranteeing a high degree of failure safety.

- Fire Alarm System
- Lighting
- Shading
- Intrusion alarm system
- Energy Management
- Energy distribution
- HVAC primary systems
- Extinguishing
- Room automation
- Perimeter monitoring
- Video surveillance
- Access control





# Building automation

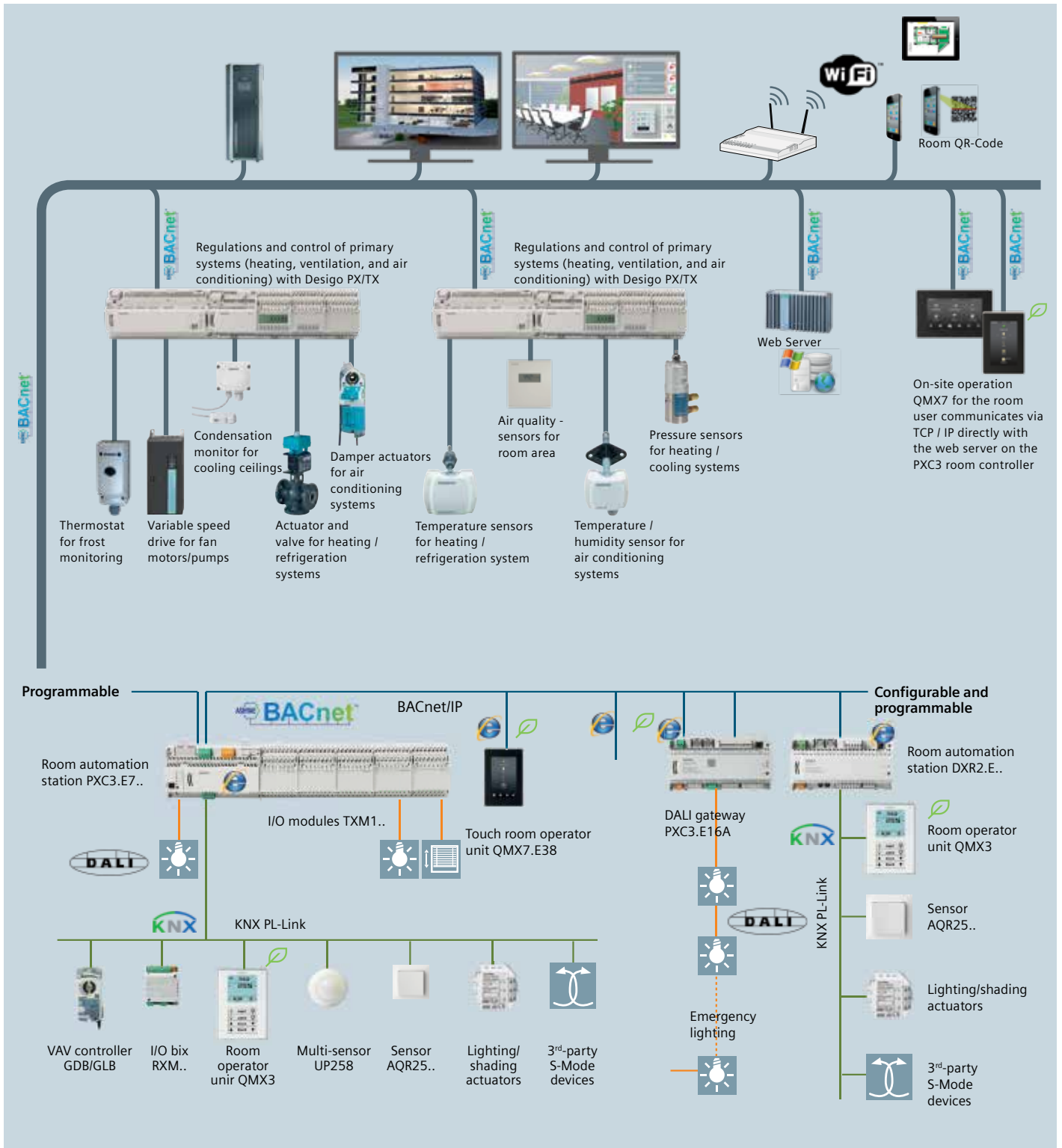





# Fire alarm

Fires can have a devastating effect and endanger goods and human life. It is therefore particularly important that fire is detected as early and as reliably as possible. Our systems are efficient and deception-proof - from the highly sensitive smoke suction system to the multi-sensor smoke detector.

## Why fire detection is important

- Ensure protection for people, assets and business continuity
- Avoidance of operational failures
- Earliest possible recognition of critical situations
- Reliable alarming of rescue workers
- Control of automatic extinguishing and evacuation systems

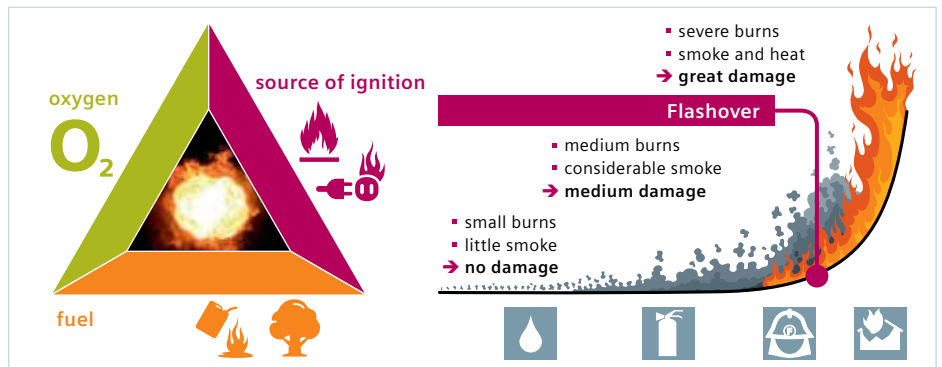

## Basics of fire detection

For a fire to break out, oxygen is required along with a combustible agent and a source of ignition. If all these three elements come together, a fire can occur. Every fire starts small. It is therefore even more important that this development is discovered as soon as possible and tackled promptly. Once the so called flashover occurs, fighting the fire is significantly more difficult and the damage is usually enormous.

## Selection of the suitable detectors

Based on these findings, the choice of the correct fire detectors is a crucial aspect. The detectors are selected depending on the type of fire that can possibly occur. In this case, it is important to take into account of possible disturbance variables in order to avoid false alarms. Fire detectors are to be tested and certified according to different EN standards (fire tests). Essentially, the distinction is made between optical, thermal, optical/thermal, linear or even flame or aspirating smoke detectors.

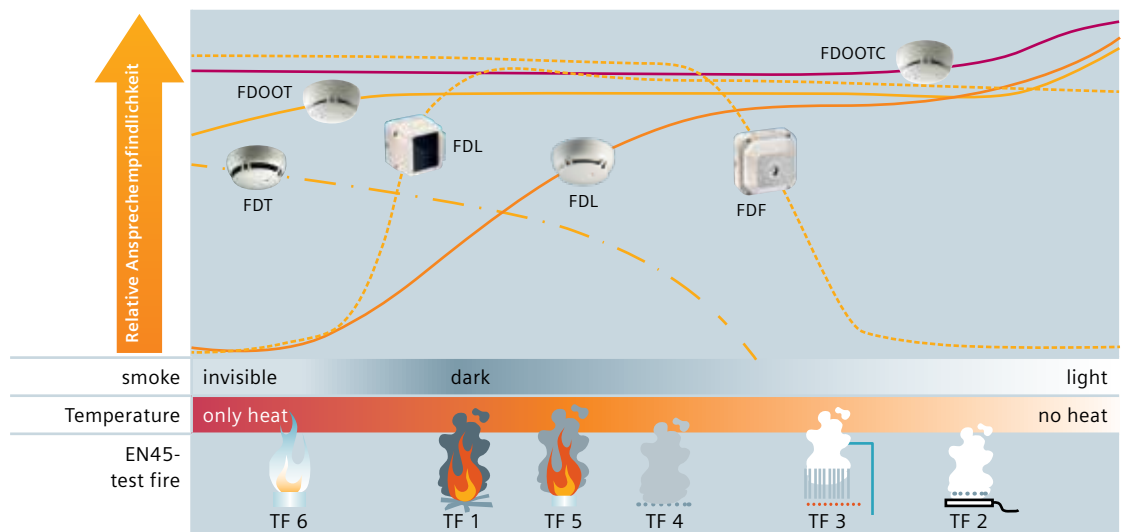



# Extinguishing

Fires rarely occur, but when they do, it is mostly with considerable consequences regarding costs. In addition to reliable detection, a fast and efficient extinguishing is a key factor to limit the damage and guarantee a fast recovery of business activities.

## Objectives of a wet - or dry extinction

- Rapid removal of one of the elements required for starting of a fire
- Damage minimization by early automatic intervention (extinction)

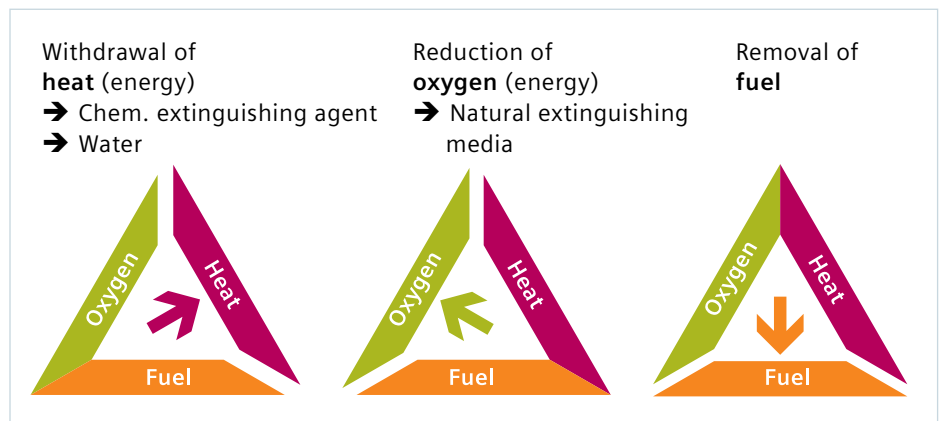

## Basic principles of extinguishing

For a fire all three elements, oxygen, combustible material (fuel) and heat must be available. If one of these elements is removed, the fire cannot spread and is extinguished. This is also the basis for the functional principle of automatic extinguishing systems.

## Types of extinguishing solution

The comprehensive portfolio for room and object protection comprises solutions with natural or chemical extinguishing agents, gas/water - combined as well as water mist solutions. It is important to ensure that the solutions are tailored to specific applications, the risk of fires and the local requirements and regulations. A suitable risk analysis and system planning as well as the subsequent system maintenance also contribute to a reliable fire protection.

Solutions with natural extinguishing agents	Solutions with chemical extinguishing agents	Gas/water-combined solution	Solution with water mist technology	Other Applications
				Sprinklers Foam extinguishing Spray flood systems Individual extinguishers



# Fire alarm

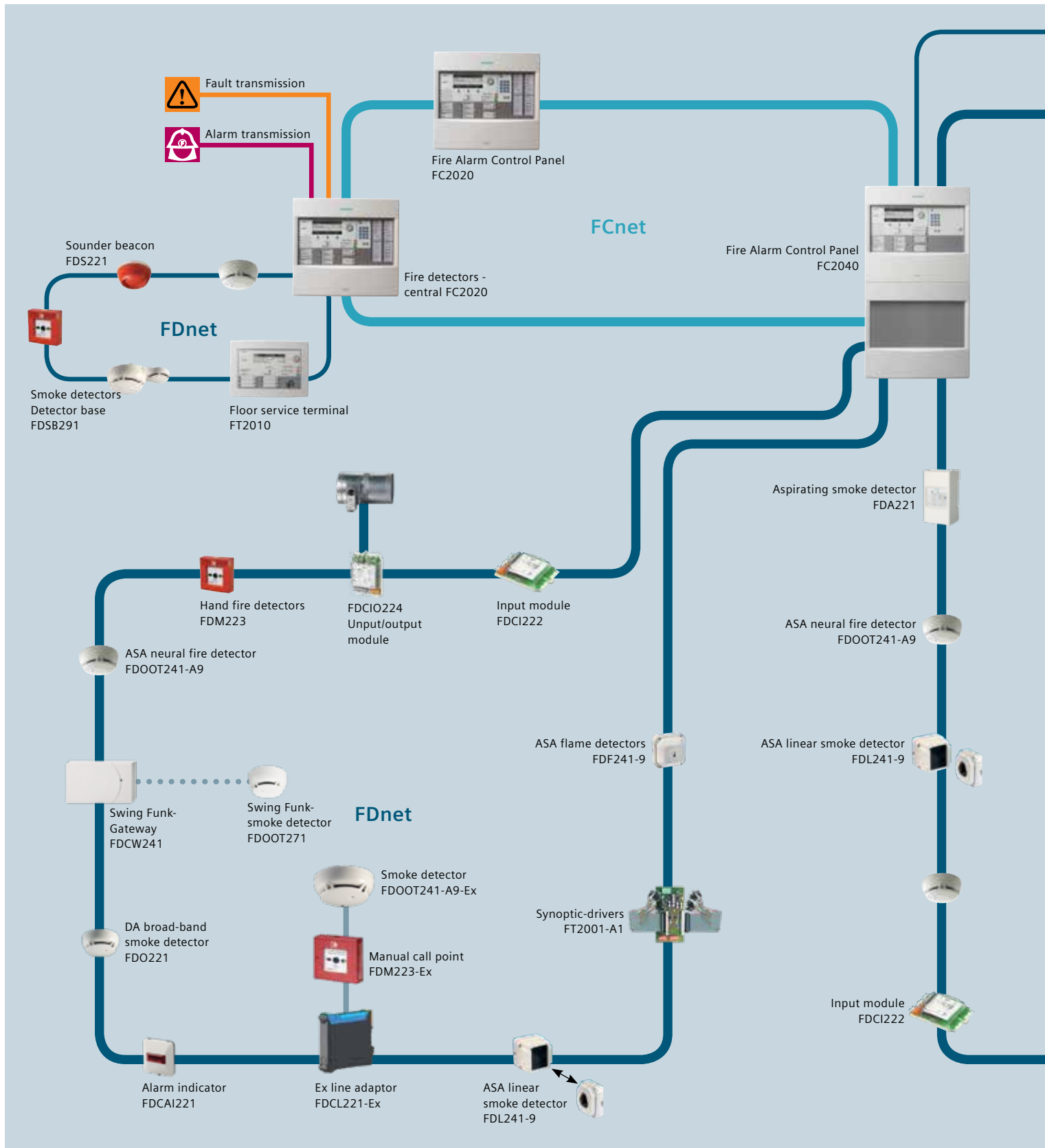





# Extinguishing

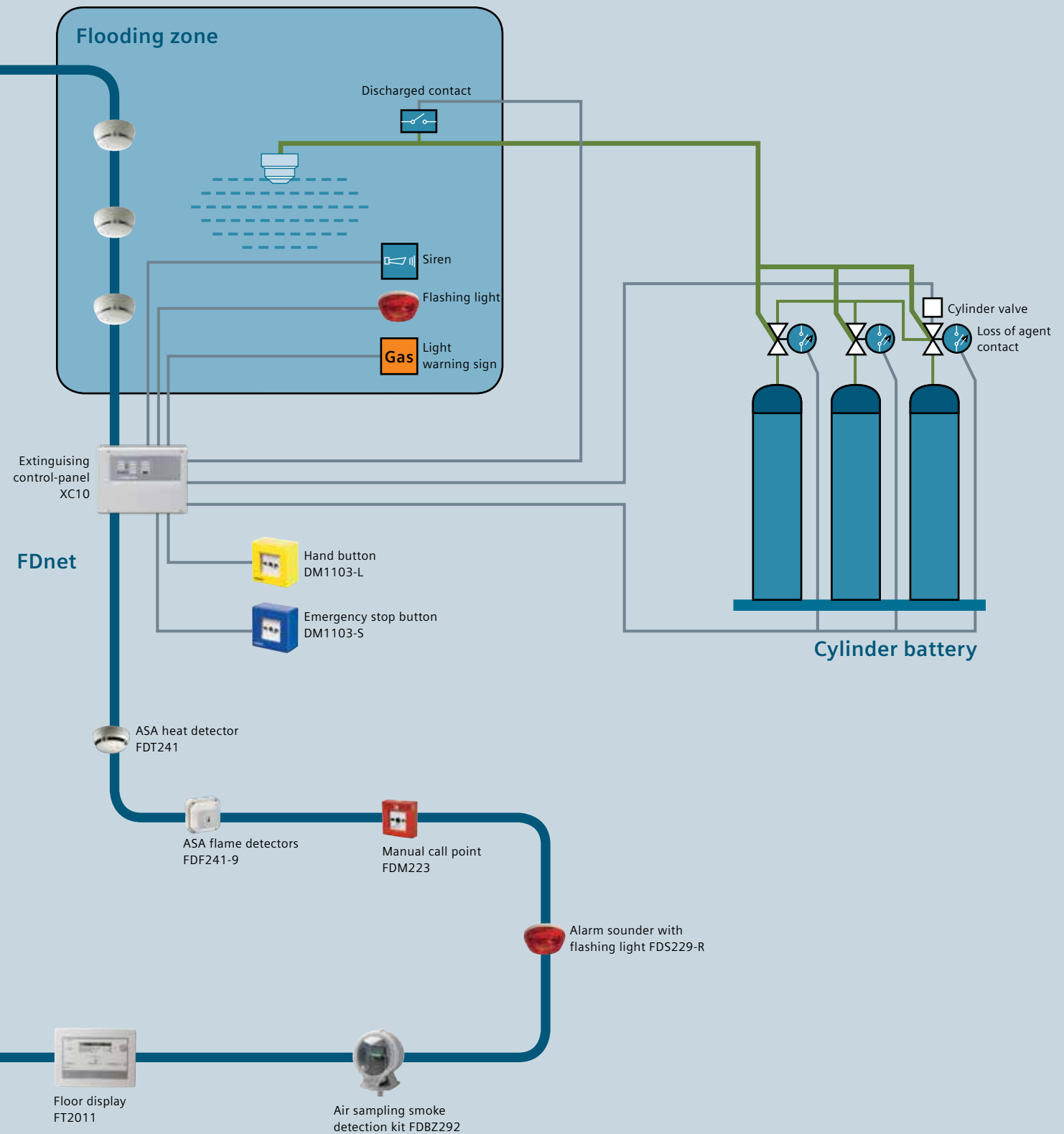



# Fire control

The absolute reliability of the fire protection system plays a vital role in building technology. Fire control is an important task of the fire alarm system in case of need. In addition to acoustic and visual warning signals, technical systems of building technology are used. For example, the elevator is moved to a predefined floor and the elevator doors are opened, while doors between individual fire sections are automatically closed.

## The advantages at a glance:

- Fail-safe loop technology are short-circuit and interruption-proof
- Simple planning and commissioning
- Flexible extension
- Visualization with LED modules or via the building management system
- Easy performance of legally prescribed tests

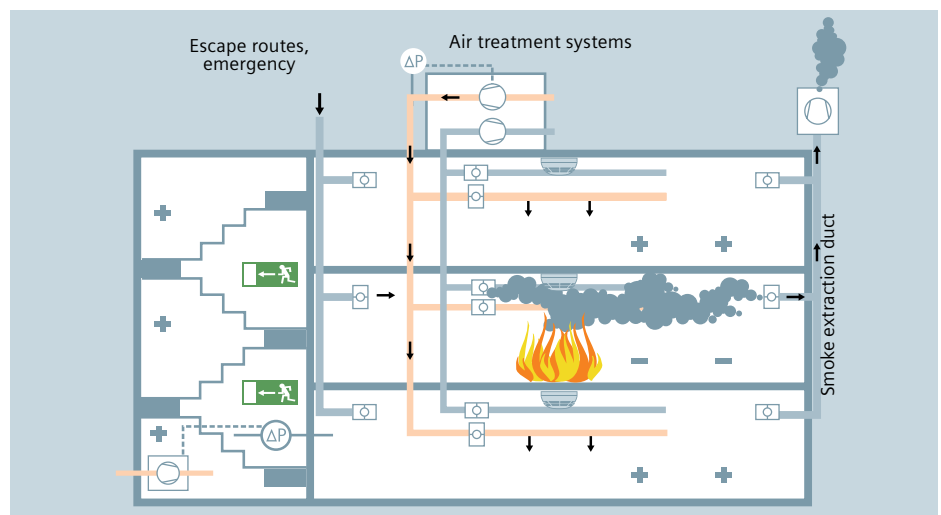

Fire dampers prevent the distribution of smoke over several sections. Fire smoke control flaps are opened in gangways and escape routes to evacuate toxic fumes and enable evacuation.

While fire and smoke control flaps shut off individual fire sections from the smoke, fire smoke thinning systems ensure that burnt gases are aspirated from the smoke areas. The ventilation systems keep escape routes and staircases smoke-free by generating a targeted overpressure.

The ventilation systems are correspondingly set and controlled for all these tasks. Siemens relies on the so-called ring bus technology. The Fire control Panel FC20 is at the heart of this system. It controls all functions from a precisely prescribed plan, the fire control

matrix. The matrix is prescribed by the

protection concept, the building code and by the TRVB S 151 (Technical Guideline for Preventive Fire Protection) and complies with legal requirements. Based on state-of-the-art technology, all systems communicate with one another and thus operate efficiently, safely and even cost-effectively. The position of the flaps or the activation of fans is either indicated in clear text on the display of the fire control panel or by means of multicolored LEDs. Optional fire indicator panels also provide information on the position of the fire detection flaps and whether the fans are switched on. Depending on the particular danger situation, the fire brigade can overwrite these settings and actively intervene in the fire situation.



# Evacuation

Evacuating a complex campus or a large industrial area in case of an emergency is not a simple undertaking. Nowadays different building parts are often used individually and people with different native languages reside here. To make sure that all persons can be informed about a hazardous situation at the same time, a public address and voice evacuation system (PA-EVAC) provides valuable and helpful services. By directly responding and calling on the people present, these can be animated to leave the building in order and for self-rescue. This allows for the fastest possible building evacuation without the occurrence of panic or jams. Life saving seconds are used efficiently.

## The aim of Public Address and Voice Evacuation System:

To deliver short and clear voice information with a high degree of comprehensiveness to the corresponding areas of a building, in order to:

- Rapidly evacuate all persons from dangerous areas to safety
- Save human lives
- Inform immediately and insure a coordinated evacuation of the building

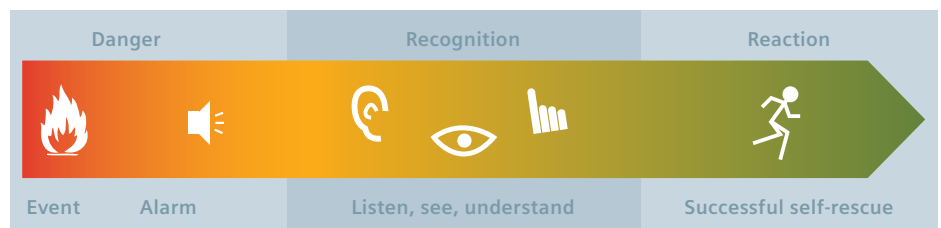

## Comfort in normal operation

In the normal operation mode, the electric-acoustic emergency warning system is used to play background music, for paging or sales offers, thus enhancing the well-being ambience and the sales figures. A real advantage for any PA-EVAC owner. In case of emergency operation however, an orderly emergency response is achieved by use of texts in different languages, gaining life saving seconds.

## Alarming and Emergency

The purpose of the alarming is to warn the user of danger by means of voice signals and to encourage the persons present to self-rescue. Life saving seconds can be gained even before the arrival of security forces. The main challenge is to have the message reach everybody in today's complex buildings as quickly as possible. An PA-EVAC with stored digital texts is the ideal and most appropriate means. A manual or automatic trigger can be used by a BMA and the ENS must correspond to TRVB 158 S.

Stages of an evacuation
Triggering the PA-EVAC by BMA or manually
The PA-EVAC ends continuous background sound
Transmission of an attention signal
Evacuation message(s), in many languages if possible.
Repetition of the announcement (s)
Possibly specific messages from the fire brigade
The building is being evacuated





# Fire control

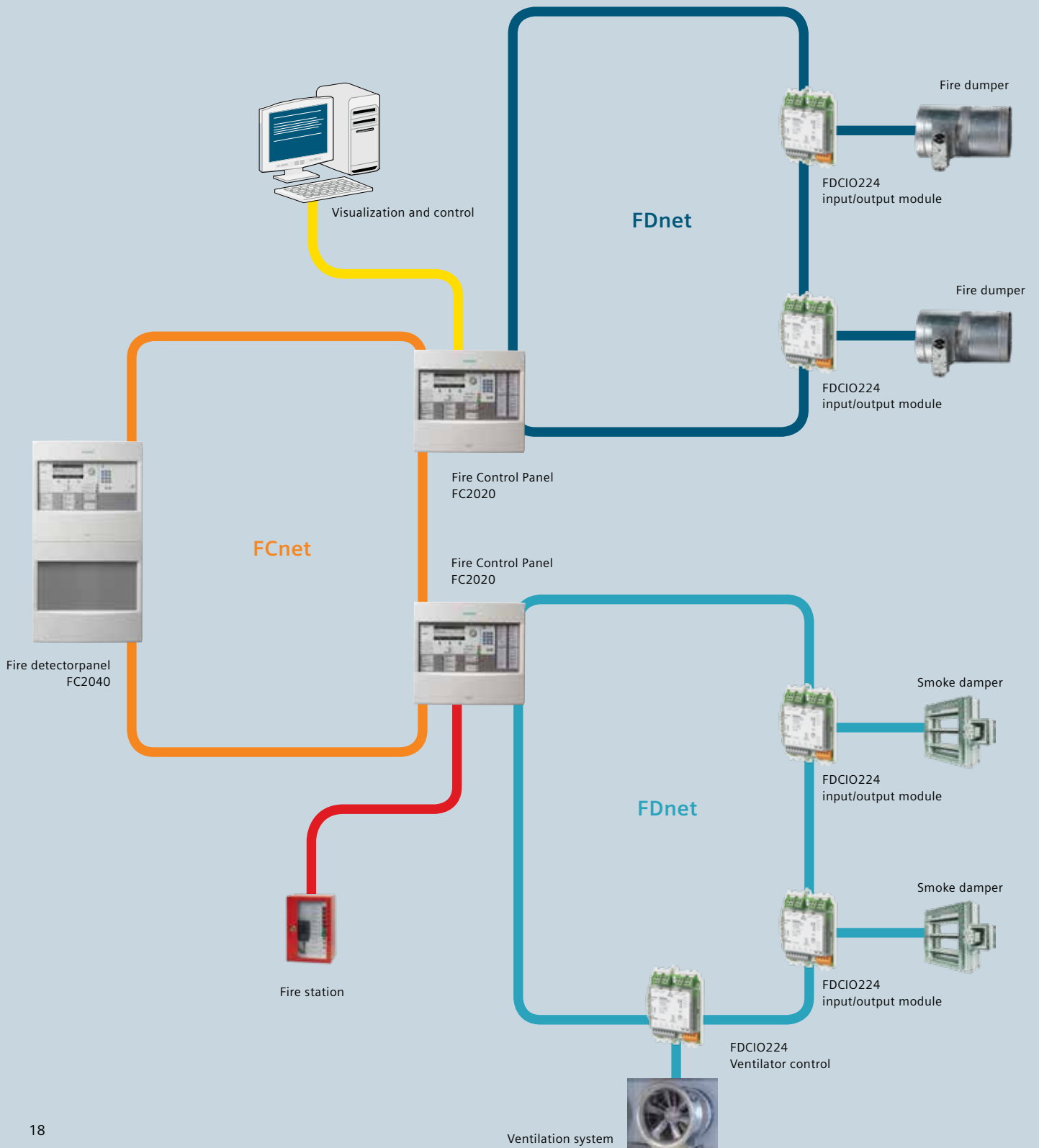



# Evacuation

## Alarm trigger by BMA

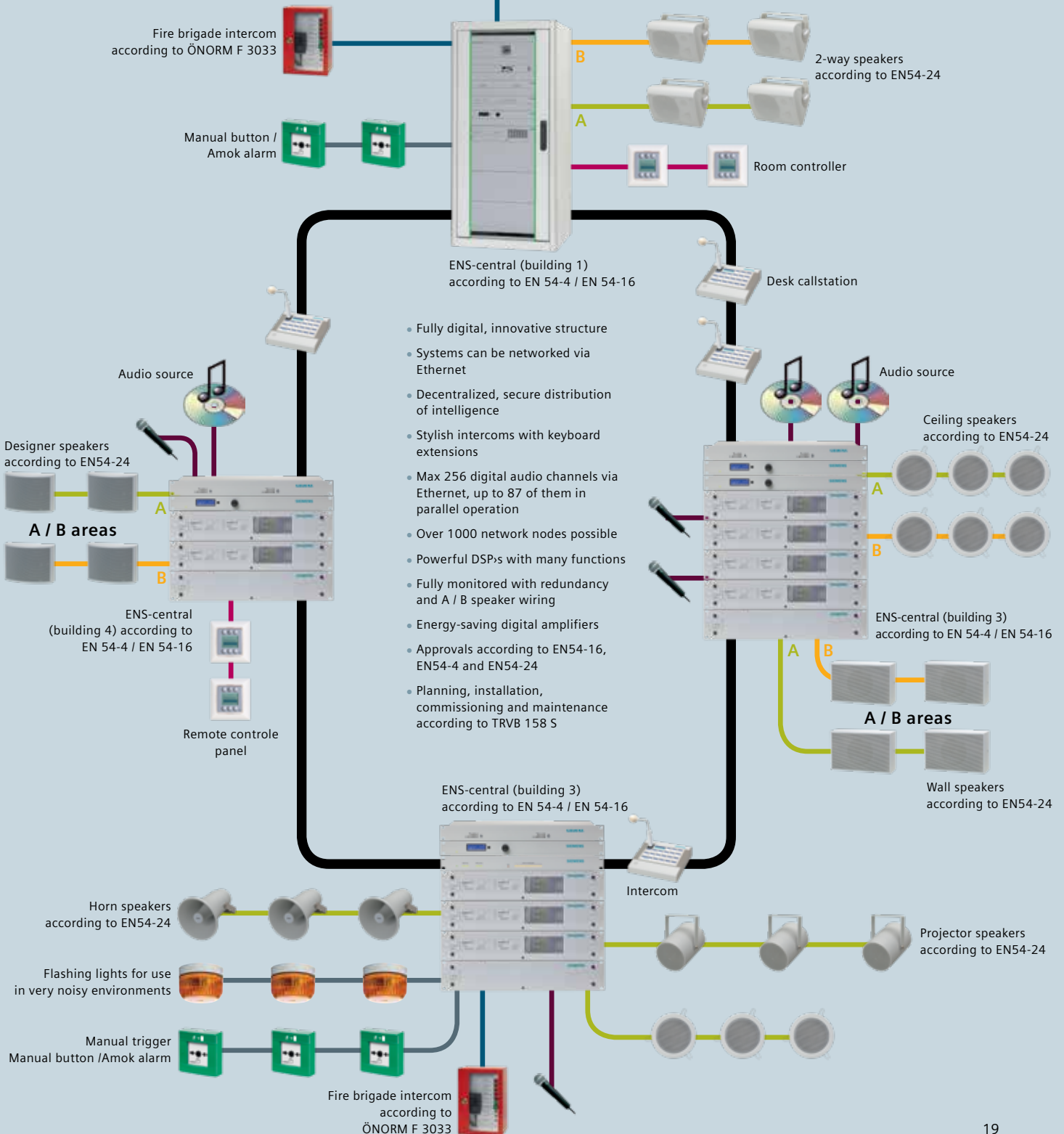



# Access control

The access control system manages the access to a building or site via criteria defined by the operator. They determine who, when and where has access, so that only authorized persons have access to the restricted areas. Access authorization can be limited to specific times and durations. Based on the proof of identity, an employee.

## Objectives of access control

- An access control system provides access to authorized persons only
- It establishes who has access when, and where



## Basics of access control

Access rights are assigned according to personal, spatial and temporal criteria. It will only allow persons identified with ID card, PIN code or biometric features to access certain areas. Access control protects buildings, equipment and persons and hinders the theft of intellectual property.



## Choice of the correct system

For the evaluation of an access system it is important to know the development and the tasks of the access control system, as well as the many requirements to the access control system. We basically make the difference between offline and online systems. For the past few years we have added the NFC-technology (Near Field Communication). This is the international standard for transmission for cost free exchange of data by radio technology and distances of a few centimetres. Applications and rights are transferred via GSM and internet. In the future, smartphones with an NFC capable SIM card can be used to replace access cards.



# Access control

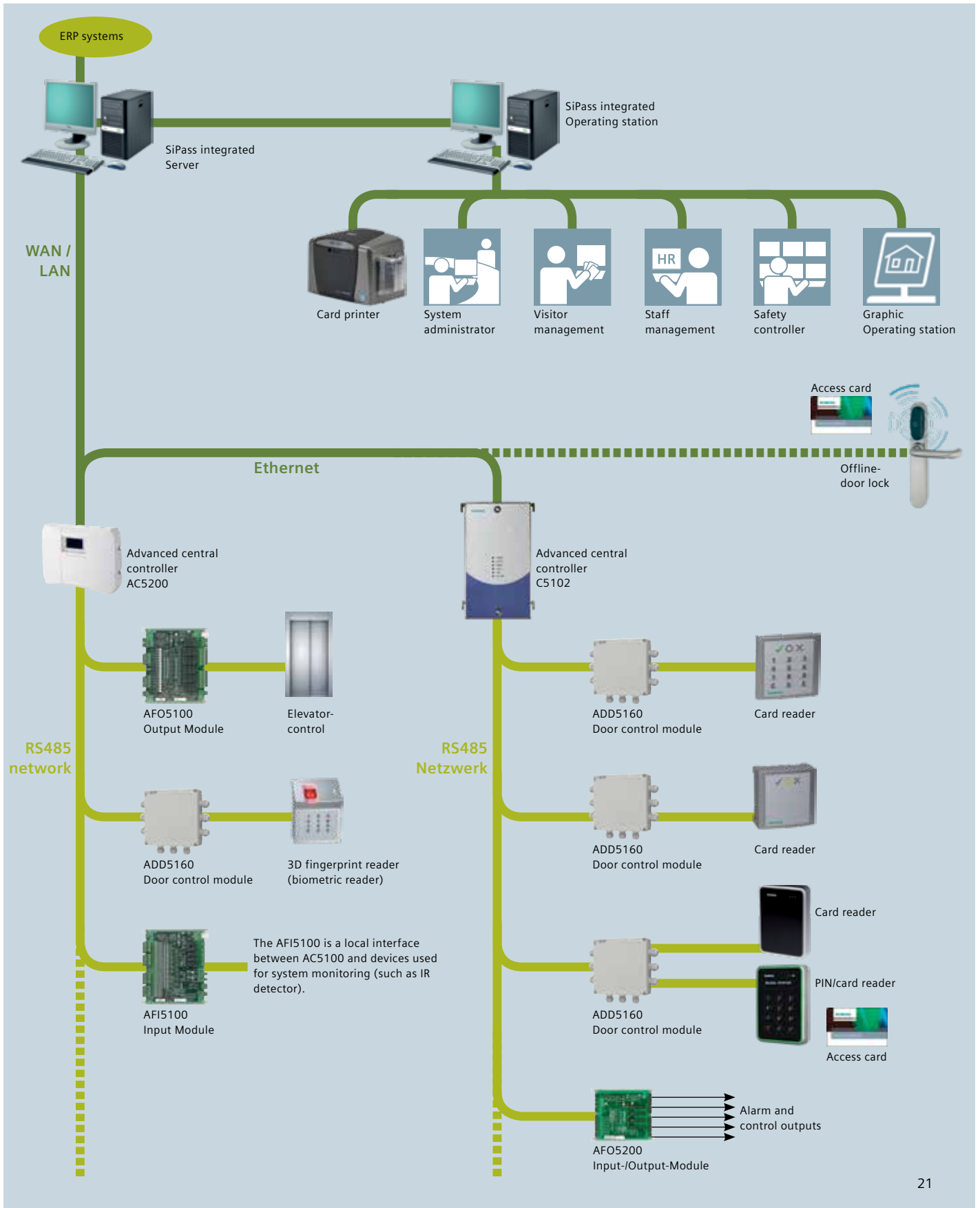



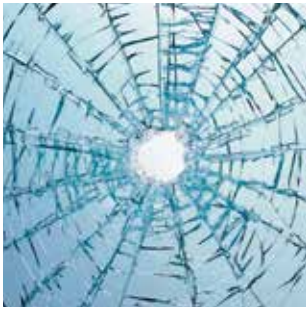

# Intrusion

Nothing can top the feeling of knowing that your family, your home and your place of business are protected. As a means of protection against intrusion, comprehensive systems and devices for the automatic detection of unauthorized access are used. The aim of the protection systems is to initiate appropriate, silent or clearly perceptible measures for the prevention of damage.

## Highlights:

Intrusion system can protect various areas with different protection objectives:

- **Perimeter monitoring:** Report unauthorized entry or access on the grounds
- **Peripheries monitoring:** Peripheries monitoring: Attack on the building exterior or building part
- **Room monitoring:** Report movements or intrusion into certain rooms or room areas
- **Object monitoring:** Attack on certain individual objects in the building
- **Attack/ protection of persons:** In case of a threat, trigger alarm (silent/loud)
- **Access control:** Allow certain persons access to parts of the building at certain times.

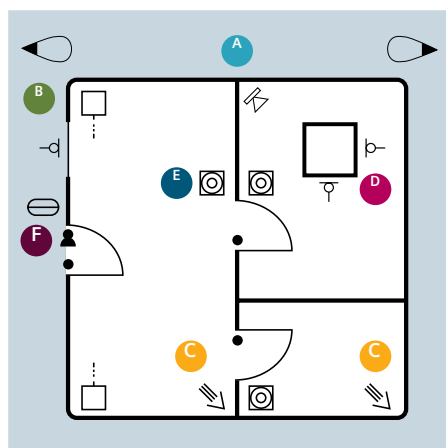
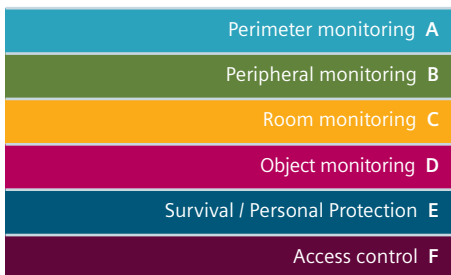

## Choice of the correct protection concept

Means of protection mostly occur based on the shell principle: They begin with the monitoring of the perimeter and include to room and object monitoring within a certain building. Depending on the areas to be protected, different detectors, systems and protective measures are suitable for the detection of intruders. The protection concept includes all the individual measures required to achieve the desired protection objectives.



# Intrusion

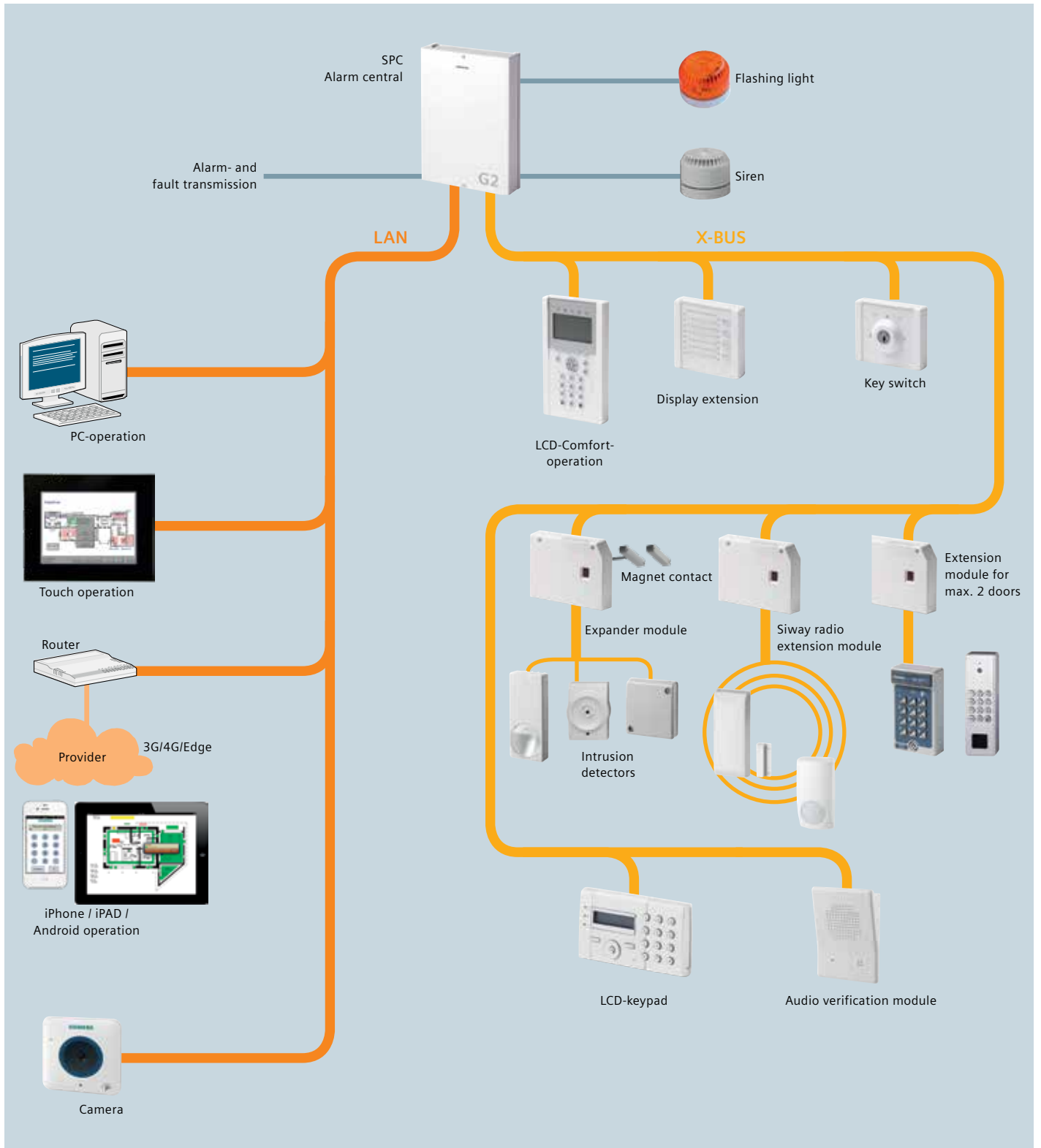



# Video surveillance

Video surveillance includes the observation of places and persons by optical electronic surveillance systems such as video cameras. This type of monitoring is often associated with the recording and analysis of the audiovisual data obtained. In most cases the data is stored digitally, so it can be analysed by software.

## Highlights:

- Surveillance of rooms, buildings and premises
- Recording of events of various nature
- Detection of heat/ fire
- Face recognition
- Detecting status changes
- Detecting mass formation
- Detecting theft
- Sign recognition (e.g. license plate recognition)



## Basics of video surveillance

The functioning of a camera can be compared with that of the human eye. It perceives an object or a person via a lens and saves the recording on a chip. Today's safety-relevant systems are becoming ever more comprehensive and complex and also have varying security requirements. Using a video surveillance

system security services are provided for 24 hours a day and 7 days a week. State of the art solutions include various types of cameras via image analysis systems and video management stations capable of evaluating the recorded images and informing the responsible staff immediately of a certain result.

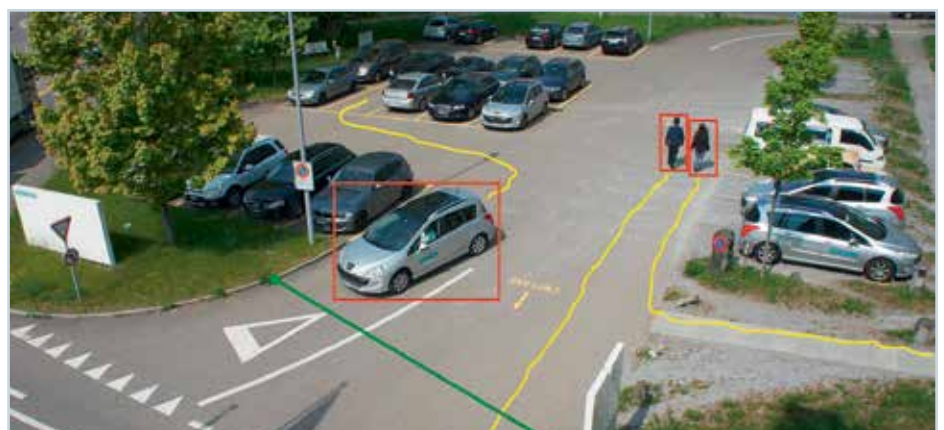



# Video surveillance

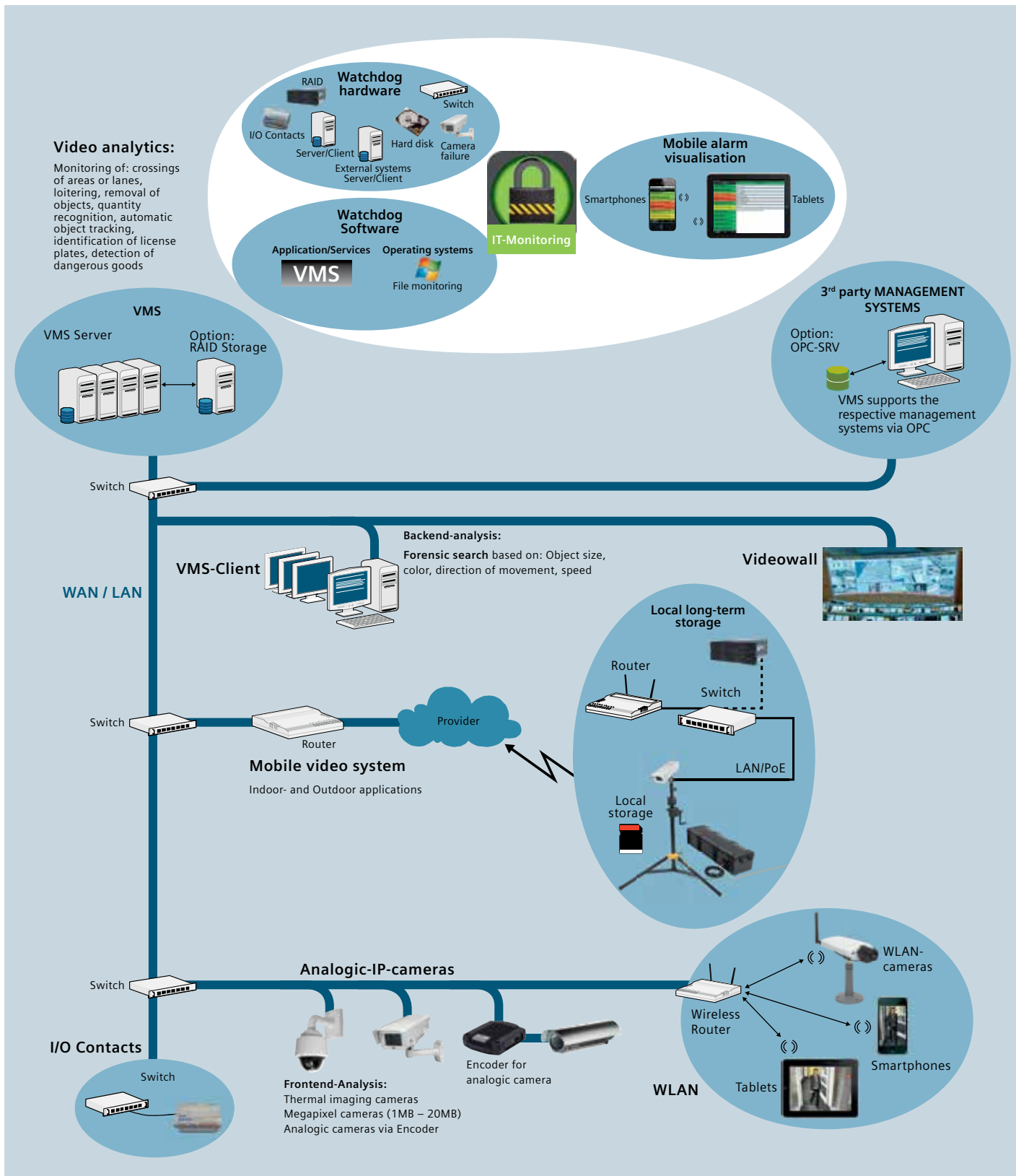





Ownership rights of the logo belong to IFIN-HH/ELI-NP.

## Extreme Light Infrastructure - Nuclear Physics (ELI-NP) - state of the art technology for safety and security, Magurele, Romania

ELI-NP is going to be the most advanced research infrastructure in the world focusing on photonuclear physics studies and applications. As the first large scale European research facility in Romania, the project is likely to become the flagship of the national scientific research, covering frontier fundamental physics, new nuclear physics and astrophysics, as well as applications in nuclear materials management, materials science and life sciences.

**The fire safety, extinguishing and security solutions consists of Siemens systems and technologies:** control software platforms like Danger Management MM8000 and building management system Desigo 5 integrating fire safety system Cerberus PRO, extinguishing system Sinorix 1230, anti-intrusion system SPC, access control system SiPass and video surveillance Sistore MX. This important and complex reference project was implemented successfully by Romtest Electronic, Siemens Solution Partner in Romania.



## Innovative solutions for a smart building - Central European University (CEU), Budapest, Hungary

In considering the design of the building systems for the new CEU campus, Siemens' task was to ensure the function and intuitive manageability of the building automation and security technology. A system of this kind contains few elements that operate in isolation and without impacting other system elements. CEU also required that the building be energy-efficient and environmentally responsible. This required innovative solutions like Siemens' Designo CC.

For example, now, the ventilation system of lecture halls is controlled automatically by signals from air quality monitoring sensors. As a result, the ventilation system

«knows» where and how much used air should be replaced with fresh air. Energy efficiency is supported by a function that automatically ventilates the entire building based on measurements of indoor air quality and temperature, and external air and weather conditions. Ventilation and temperature can also be adjusted based on a room's occupancy or time of day. The building's fire alarm, access control, and camera systems were also integrated into the design.

Siemens state-of-the-art technology is an important part of CEU's two new buildings, contributing to energy efficiency and cost savings.



## Safety and comfort for Radisson Blu Plaza Hotel, Ljubljana, Slovenia

To increase the safety and comfort of their guests, the Radisson Blue Plaza Hotel Ljubljana needed a smart solution. The Siemens Solution Partner installed a Cerberus PRO fire protection system as well as a range of building automation solutions.

The luxury hotel Radisson Blu Plaza Hotel Ljubljana required an integrated solution to ensure the safety and comfort of their guests. Apart from reliable and efficient the comfort and safety devices also had to

be invisible to guests. The solution, installed by A koda plus Ltd., Siemens Slovenia Solution Partner consisted of the Cerberus PRO fire protection system as well as a range of building automation solutions, all managed by the Desigo Insight system.

Now, Radisson Blu Plaza Hotel in Ljubljana beneficiaries from state-of-the-art safety, security and energy efficiency thanks to Siemens discreet and architecturally harmonized solutions.







## Safety of the students personnel and equipment come first in an university. University in Rijeka, Croatia

10 buildings and over  
100,000 m<sup>2</sup> of challenges

This project's greatest challenge was to integrate the central control and management systems of the ten buildings constituting the University Campus into one service within the University's technical department – the Department for Control and Management.

Synova and Sinteso solutions are used for fire detection, SiPass for access control and Siemens SPC series for anti-theft protection. The main advantage of the current fire detection system, which was

supplied by Siemens, is in the total solution for surveillance and monitoring of a building complex like University Campus Rijeka that currently has 10 buildings (many more are planned), and many more advantages like an integral approach to all systems (safety systems and systems of fire and gas protection), management of these with a small number of staff, service support and authorized licensed partners in maintenance, and reducing costs of energy consumption.



# Maximum comfort and reliable safety for Sofia Ring Mall, Bulgaria

The newest and largest shopping mall in Bulgaria was equipped with a Building Management System from the Desigo family as well as with a complete range of fire safety products and security systems - Cerberus PRO, XC10, MM8000, SiPass Integrated and Vectis IX IP CCTV. Siemens Building Technologies Bulgaria meets the client's request for optimal energy efficiency without sacrificing comfort and for a state-of-the-art fire safety and security installation, capable of reliable protection of both people and assets.

Now, Sofia Ring Mall beneficiaries from building performance that provides both maximum comfort and reliable safety – a proven way to retain the end customer's satisfaction and the key goal for the shopping mall's management. Also, there is a substantial decrease of energy consumption which means lower costs and long-term sustainability.



# The first Desigo CC reference in South East Europe - Acibadem City Clinic Cancer Center in Sofia, Bulgaria

The first Desigo CC reference in South East Europe is Acibadem City Clinic Cancer Center in Sofia, Bulgaria. The clinic has a total area of 10,000 sqm and a 80-bed capacity. Its medical staff exceeds 240 doctors and healthcare professionals.

Siemens Bulgaria Solution Partner, New System Ltd., implemented DESIGO CC with 3500 data points. The project included the integration of room temperature thermostats and VRF units, DDC and field equipment for 11 Air handling units, DDC and field equipment for heating and cooling center, monitoring and control of ventilation in general areas, monitoring and control of chillers, pump, fans and others, monitoring and control of smoke dampers system and of diesel generator using Modbus protocol along with the monitoring of fire safety and security systems, including fire alarm, intrusion detection and access control systems, monitoring of power supply system and of medical emissions system.





For more  
informations  
about  
The Crystal  
scan the QR code:



The Crystal, the global center for sustainable urban development built and operated by Siemens in London, is setting new standards in environmentally friendly and sustainable buildings. Award with LEED (Leadership in Energy and Environmental Design) Platinum, BREEAM (Building Research Establishment Environmental Assessment) "Outstanding" certificate, the Crystal consumes 46 percent less energy and emits 65 percent less carbon dioxide than comparable office buildings.

The advanced Desigo building automation system from Siemens controls and monitors all building operating parameters while the Siemens Advantage Operation Center (AOC) in Frankfurt, Germany, handles remote maintenance. The Crystal's users and visitors can see the latest energy and water consumption figures on Green Building monitors, motivating them to adopt environmentally friendly and sustainable practices in their own lives.

When building technology creates perfect places –  
that's Ingenuity for life.

Never too cold. Never too warm.  
Always safe. Always secure.

With our knowledge and technology, our products,  
our solutions and our services, we turn places into  
perfect places.

We create perfect places for their users' needs –  
for every stage of life.

**#CreatingPerfectPlaces**  
**[siemens.com/perfect-places](https://www.siemens.com/perfect-places)**

**Published by**

**Siemens Building Technologies SEE**  
[Siemens.com/seeteam](https://www.siemens.com/seeteam)

**Meet our  
team!**



The information given in this document only contains general descriptions  
and/or performance features which may not always specifically reflect those  
described, or which may undergo modification in the course of further  
development of the products. The requested performance features are binding  
only when they are expressly agreed upon in the concluded contract.