

SIEMENS

P1-250 Panelboard Kit MLKC1A & MLKC3A Main / Feed-thru Lugs

(for use in Revised P1 Panelboards ONLY)¹

Installation
Instructions

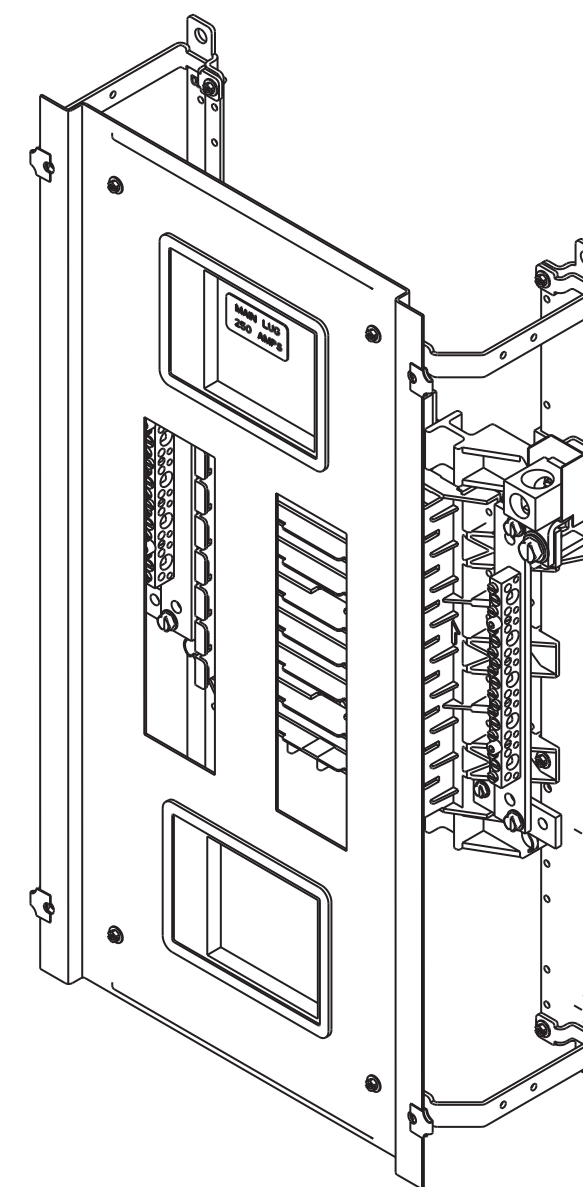

These instructions do not purport to cover all details or variations in equipment, or to provide for every possible contingency to be met in connection with installation, operation or maintenance. Should further information be desired or should particular problems arise, which are not covered sufficiently for the purchaser's purposes, the matter should be referred to the local Siemens sales office. The contents of this Instruction manual shall not become part of or modify any prior or existing agreement, commitment or relationship. The sales contract contains the entire obligation of Siemens. The warranty contained in the contract between the parties is the sole warranty of Siemens. Any statements contained herein do not create new warranties or modify the existing warranty.

Trademarks - Unless otherwise noted, all names identified by © are registered trademarks of Siemens AG or Siemens Industry, Inc. The remaining trademarks in this publication may be trademarks whose use by third parties for their own purposes could violate the rights of the owner.

¹ To confirm, note the part number of the panel (marked on the interior label).
If it ends in an "N" or a "T" it is a "Revised P1" and is compatible with this kit.
(For example: P1E42MC250A is an Original P1; P1E42MC250AT is a Revised P1)

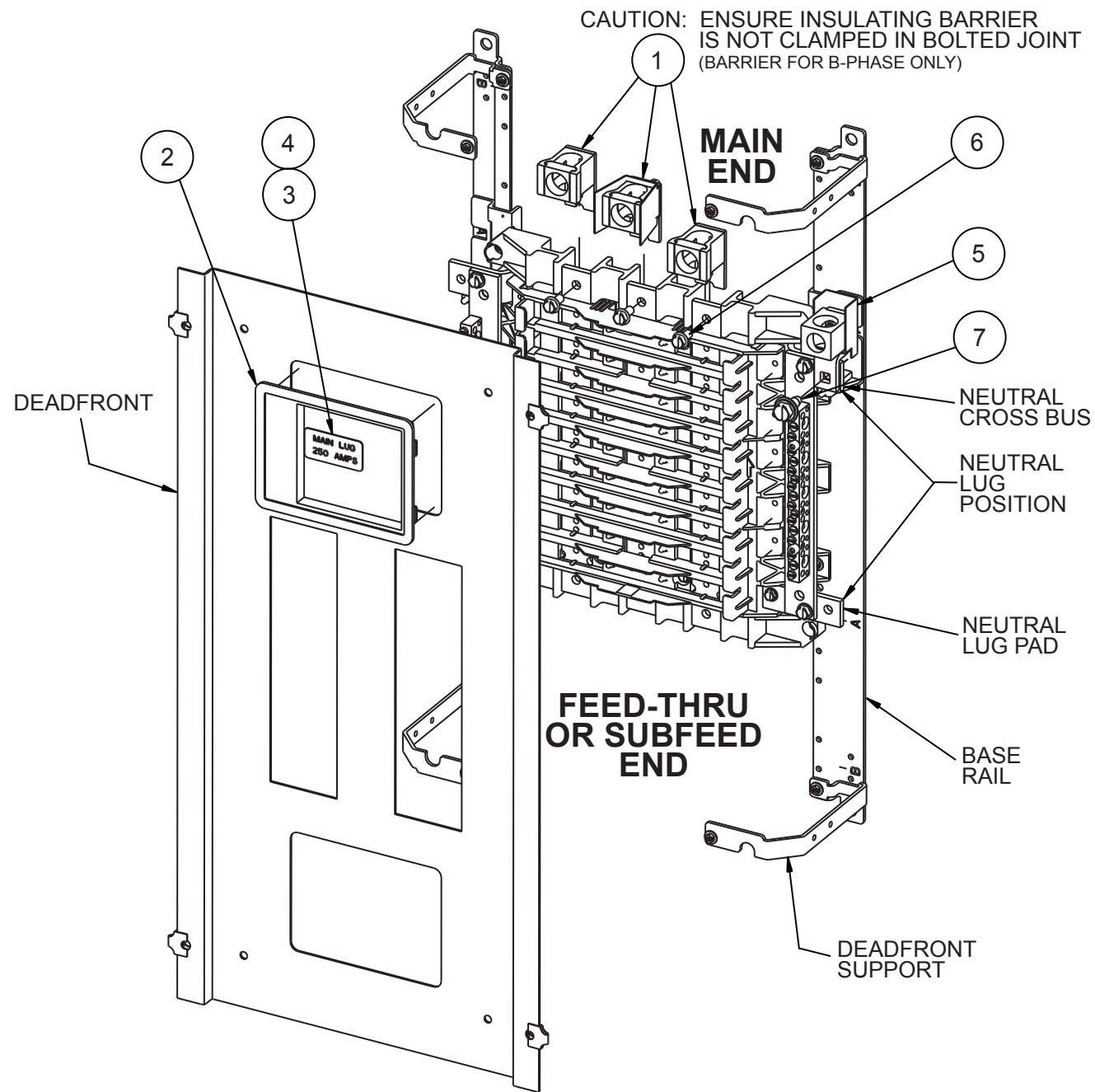

THIS KIT CONTAINS THE FOLLOWING ITEMS:

ITEM	DESCRIPTION	QTY
1	MAIN LUG ASSEMBLY	**
2	BLANK FILLER	1
3	125A MAIN LUG LABEL	1
4	250A MAIN LUG LABEL	1
5	NEUTRAL LUG ASSEMBLY	1
6	1/4"-20 x 1/2" HEX HEAD SEMS* ASSEMBLY SCREW	**
7	5/16"-18 x 3/4" SLOTTED HEX WASHER THREAD-FORMING SCREW	1

* SEMS ASSEMBLY SCREWS HAVE A CAPTIVE WASHER ON THE SCREW

** (2) FOR 1Ø, (3) FOR 3Ø

Installation Instructions

The following instructions are for the installation of Siemens main/feed-thru copper lug kits in a Revised P1 Panelboards. The parts provided in this kit are for connection to a 1-phase 2 or 3-wire system in kit MLKC1A and for connection to a 3-phase 3 or 4-wire system in kit MLKC3A. For systems with no neutrals disregard the neutral connection.



1. Lock off all power supplying this equipment before working on it.

2. Remove the deadfront.

For installation as main lugs:

3. To install this kit for main lug use, remove the main (if installed).

4. Place the main lug assemblies (item 1) under the exposed main bus. Fasten to the main bus using the 1/4"-20 hex head SEMS assembly machine screws (item 6) provided.

5. Torque all connections to the values specified on the Hardware Tightening Torque label affixed to the rear of the deadfront.

6. Attach the cables to the lugs and torque connections to values specified on the Hardware Tightening Torque label affixed to the rear of the deadfront.

7. Remove any breaker fillers or escutcheons (if installed) and fill the opening with the blank filler (item 2) provided with this kit.

8. Labels are provided (items 3 & 4) to mark the ampacity of the panel's main lugs (either 125A or 250A). Apply the appropriate label to the center of the installed blank filler (item 2).

9. On 1-phase 3-wire and 3-phase 4-wire systems the neutral lug assembly (item 5) is required. The neutral lug assembly comes in the kit ready to assemble at any open corner. Position the lug sub-assembly on top of the neutral cross bus and secure with a 5/16"-18 thread-forming screw (item 7) as shown. Refer to the Hardware Tightening Torque label affixed to the rear of the deadfront.

10. Before energizing the panel, ensure that all connections have been properly torqued, that the deadfront is installed and that all fillers are in place.

For installation as feed-thru lugs*:

11. Follow steps 1 through 9 except that any existing subfeed or feed-thru lug assemblies are to be removed. In addition, do not install the main lug ampacity labels. Finish with Step 10.

* For panels with feed-thru or subfeed space ONLY