

The image features a Siemens SIMOTICS motor in the foreground, a glowing digital control cabinet in the background, and a grid of binary code (0s and 1s) on a blue background. The motor is a compact, cylindrical unit with a metal shaft. The control cabinet is a rack-mounted unit with several slots and glowing components. The background is a dark blue grid with vertical columns of binary code. The Siemens logo is in the top left corner.

SIEMENS

SIMOTICS – compact, dynamic and rugged

The optimum motor
for every motion control application

[siemens.com/motion-control-motors](https://www.siemens.com/motion-control-motors)

Contents

SIMOTICS motion control – if you want to move something	3
Optimum integration in the drive and control system	4
Servomotors for every motion application	5
Our servo drive systems – can be simply engineered for your application	11
Main motors with outstanding performance up to 40,000 rpm	13
The benchmark for directly driving linear axes	16
Always providing the right spin at precisely the right time	18
MOTION-CONNECT connection system – the simple, fast and reliable connection	20
DRIVE-CLiQ – for plug & play commissioning and increased transparency for monitoring motors	21
SIZER, DT Configurator and CAD CREATOR: drive engineering – simple and fast	22
SIMOTICS motion control motors – an overview	23
Mechatronic support: faster to the machine – faster to market	25

SIMOTICS motion control – if you want to move something

Since the development of the dynamo-electric principle by Werner von Siemens back in 1866, innovative motor technology represents a core business of our company.



In addition to low-voltage, DC and high-voltage motors, SIMOTICS motion control motors have firmly established themselves in many sectors when it comes to addressing demanding motion control applications.

The correct solution

Whether for precise and repeatable positioning, constant speed and high dynamic motion, long traversing paths or fast velocity changes – the Siemens SIMOTICS portfolio of servo, main, linear and torque motors has the optimum solution for each and every motion control task.

SIMOTICS motion control motors are based on

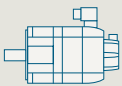
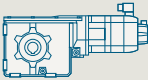
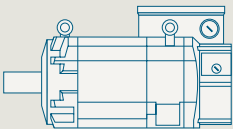

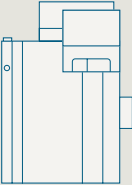



- 150 years of experience and innovation in electric motor technology
- The widest range of motors worldwide with optimum solutions for motion control tasks in all sectors and power classes
- Can be consequentially integrated in the drive train to create overall systems, perfectly addressing the control concept
- Rugged and compact design for reliable, low-maintenance operation with the highest dynamic performance and precision
- A global network of skill sets and worldwide service around the clock

SIMOTICS motion control motors				
SIMOTICS S servomotors	servo geared motors	SIMOTICS M main motors	SIMOTICS L linear motors	SIMOTICS T torque motors
				

Optimum integration in the drive and control system

Our SIMOTICS motion control motors are perfectly harmonized and coordinated for operation with our SINAMICS frequency converters. This simplifies engineering and commissioning system solutions for high-performance applications in plant and machinery construction.

To optimize interaction with the converter, the motors have a DRIVE-CLiQ interface to quickly transfer data – and transparently monitor important motor data. Further, SIMOTICS motion control motors operate perfectly with SIMATIC, SINUMERIK and SIMOTION control systems from Siemens.

Seamless integrated motion control solutions				
Control system	 SIMATIC	 SINUMERIK	 SIMOTION	
Converter	 SINAMICS V90	 SINAMICS S210	 SINAMICS G120	 SINAMICS S120
MOTION-CONNECT				
Motor	 SIMOTICS S servomotors	 SIMOTICS M main motors	 SIMOTICS L linear motors	 SIMOTICS T torque motors

Servomotors for every motion application

No matter whether positioning, angular synchronism, cyclic drives or path control in machine tools: With SIMOTICS servomotors you profit from high dynamic performance, precision, compactness and ruggedness.

SIMOTICS S-1FK7 – cost-effective, flexible and universal

With our SIMOTICS S-1FK7 servomotors, depending on the requirements relating to dynamic performance, control response, precision and space, there are three moment of inertia versions to select from – when required, also in combination with a gearbox.

SIMOTICS S-1FK7 Compact (CT)

High power density with a short length makes our SIMOTICS S-1FK7 Compact (CT) motors predestined for universal use in applications where space is restricted.

SIMOTICS S-1FK7 High Dynamic (HD)

SIMOTICS S-1FK7 High Dynamic (HD) motors set themselves apart as a result of their low rotor diameter. This minimizes the intrinsic moment of inertia and facilitates a high dynamic performance. This makes them the ideal choice when it comes to motion sequences with very short cycle times demanding a high dynamic performance.



Highlights SIMOTICS S-1FK7

- Three versions with different moments of inertia: Compact, High Dynamic and High Inertia
- High efficiency and 300 percent overload capability
- Resistant to shock and vibration as the encoder is mechanically decoupled
- Optionally with absolute encoder, incremental encoder or resolver
- Installation- and service-friendly using a rotatable quick-release connector and replaceable encoder
- Digital DRIVE-CLiQ interface with electronic type plate for optimal connection to SINAMICS S120
- Optionally with different gearbox types and backlash-free holding brake
- Cooling methods: Natural cooling and forced ventilation (for SIMOTICS S-1FK7 HD Shaft Height 80)

SIMOTICS S-1FK7 High Inertia (HI)

The increased intrinsic moment of inertia of our SIMOTICS S-1FK7 High Inertia (HI) motors ensures an extremely rugged control response, ideal for applications with high and variable load moments of inertia.

SIMOTICS S-1FK7 with mounted planetary gearbox

When specified, we can also supply S-1FK7 motors with a mounted planetary gearbox. High-precision and economic planetary gearboxes are available to address a wide range of applications. You profit from high smooth running properties and compactness for motion control applications.



Typical application areas

- Packaging machines
- Plastics and textile machines
- Printing machines
- Wood, glass, ceramic and stone processing machines
- Robots, handling systems and conveyor technology
- Feed and auxiliary axes for machine tools



SIMOTICS S-1FK7 servomotors – an overview

SIMOTICS S-1FK7	Standstill torque*	Rated speed*	Rated power*
CT – Compact	0.2 – 48 Nm	up to 6000 rpm	0.05 – 8.2 kW
HD – High Dynamic	1.3 – 38 Nm	up to 6000 rpm	0.6 – 7.5 kW
HI – High Inertia	3 – 48 Nm	up to 6000 rpm	0.9 – 7.7 kW

* depending on the version and type

SIMOTICS S-1FT7 – maximum power and performance with customized cooling

Our SIMOTICS S-1FT7 motors are completely in their element when it comes to high-performance motion applications in the torque range up to 280 Nm. They are available in two different versions with various cooling methods:

SIMOTICS S-1FT7 Compact motors (CT)

Naturally cooled, force-ventilated or water-cooled 1FT7 motors are predominantly used where space is restricted and a high power density is required. Their low torque ripple makes them predestined for machine tool applications where a high surface quality is critical.

SIMOTICS S-1FT7 High Dynamic motors (HD)

This version sets itself apart as a result of the extremely low intrinsic moment of inertia. This makes them predestined for applications demanding the highest dynamic response and shortest cycle times. 1FT7 High Dynamic motors are available with forced ventilation and water cooling – and are characterized by their high continuous power capability.

SIMOTICS S-1FT7 with mounted planetary gearboxes

When specified, we can also provide our S-1FT7 motors with mounted planetary gearboxes. High-precision planetary gearboxes are available to address a wide range of applications. With these motors, you profit from high smooth running properties and a high degree of compactness for motion control applications.



Highlights

SIMOTICS S-1FT7

- Two versions with different moments of inertia: Compact, High Dynamic
- High efficiency and 400 percent overload capability (for naturally cooled versions)
- High surface quality of the workpiece through low radial eccentricity and low torque ripple
- Either naturally cooled, force-ventilated or water-cooled
- IP67 degree of protection makes them extremely rugged – and encoders are mounted so that they are decoupled from any oscillation and vibration
- Optionally with absolute encoder or incremental encoder
- Service-and-installation-friendly using the crossover profile, quick release connector that can be rotated and a replaceable encoder
- Digital DRIVE-CLiQ interface with electronic type plate for optimum connection to SINAMICS S120 converters
- Optional: holding brake with no backlash – and planetary gearbox with low backlash

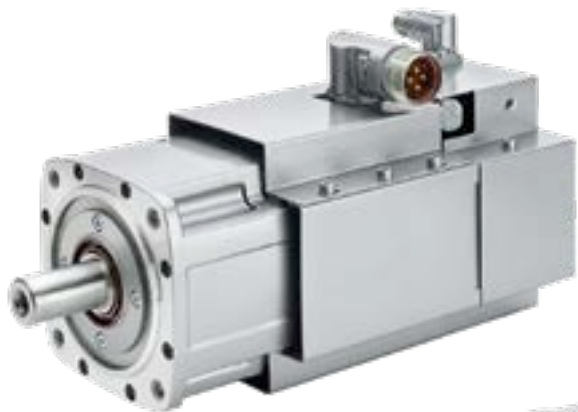

Forced ventilation

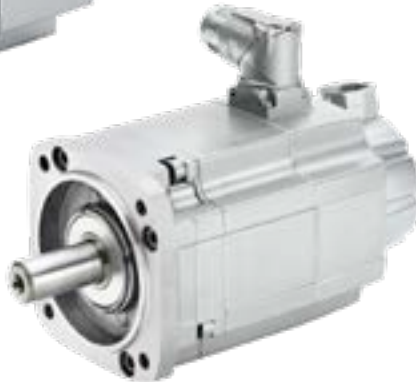

Natural cooling



Water cooling

Typical application areas

- Machine tools
- Packaging machines
- Printing machines
- Conveyor technology and handling systems



SIMOTICS S-1FT7 servomotors – an overview

SIMOTICS S-1FT7	Standstill torque*	Rated speed*	Rated power*
CT – Compact	2 – 280 Nm	up to 6000 rpm	0.88 – 45.5 kW
HD – High Dynamic	14 – 105 Nm	up to 4500 rpm	3.8 – 21.7 kW

* depending on the version and type

SIMOTICS S-1FG1 – open for a wide range of gearboxes

The concept of our SIMOTICS S-1FG1 servo geared motors is attractive as a result of the variable configuration options that can be used to create customized solutions both regarding type of construction and power rating. Irrespective of whether your application requires a helical, parallel shaft, bevel or helical worm gearbox: With high efficiencies, low torsional backlash and finely graduated ratios, these motors can optimally address a wide range of different motion control applications.

Optimum interaction

These servo geared motors are optimally adapted to the SINAMICS S120 drive system and the various commissioning tools – facilitating seamless integration into the drive and automation environment. Commissioning can be performed especially quickly using the DRIVE-CLiQ system interface and electronic type plate. Prefabricated MOTION-CONNECT power and signal cables mean that perfect connections can be simply established to all components involved.



Highlights SIMOTICS S-1FG1

- Versions for standard (Compact) and especially fast load cycles (High Dynamic)
- Naturally cooled design with a high power density
- Helical gearing for very smooth operation
- Wide range of versions based on four gearbox types and up to 35 ratios
- High transmission ratio in the first gearbox stage allows two instead of three stage gearboxes to be used – resulting in a two percent higher efficiency with lower temperature rise
- Digital DRIVE-CLiQ interface with electronic type plate for optimum connection to SINAMICS S120 converters



Helical geared motor



Parallel shaft geared motor



Bevel geared motor



Helical worm geared motor

Typical application areas

- Packaging machines
- Printing machines
- Wood and metal processing
- Palletizers and storage & retrieval machines with hoisting, gantry and fork drives
- Dosing pumps and actuator drives



SIMOTICS S-1FG1 servo geared motors – an overview

SIMOTICS S-1FG1	Helical geared motor 2-stage (Z), 3-stage (D)	Parallel shaft geared motor 2-stage (Z), 3-stage (D)	Bevel geared motor, 2-stage (B), 3-stage (K)	Helical worm geared motor, 2-stage
Gearbox designations	Z19 – Z129, D19 – D129	FZ29 – FZ129, FD29 – FD129	B19 – B49, K39 – K149	C29 – C89
Max output torque (Nm)	14 – 1890 (Z), 102 – 5000 (D)	17 – 5000 (FZ), 163 – 5010 (FD)	14 – 465 (B), 24 – 8160 (K)	46 – 1520
Range of transmission ratios	3.4 – 62.5 (Z), 35.78 – 373 (D)	3.6 – 65.2 (FZ), 46.4 – 413 (FD)	3.5 – 59.3 (B), 5.2 – 244.3 (K)	6.2 – 363

Our servo drive systems – can be simply engineered for your application

SIMOTICS S-1FL6 and SINAMICS V90 – can be flexibly configured in the lower power range

In conjunction with SINAMICS V90 inverters, our SIMOTICS S-1FL6 servomotors form a seamlessly integrated drive system with eight inverter sizes and seven motor versions.

Based on their optimized moment of inertia, the motors handle continuous motion – such as winding and punching – with very high smooth running characteristics. Versions with a very low moment of inertia are available for motion sequences demanding a high dynamic performance with high positioning accuracy.



Highlights SINAMICS V90 and SIMOTICS S-1FL6

- Two versions with different moments of inertia: Low and High Inertia
- Three hundred percent overload capability and high IP65 degree of protection
- With either incremental or absolute encoder
- Quick release connector for simple motor installation
- Servo tuning and machine optimization using the auto-tuning function
- All frame sizes have an integrated braking resistor
- Optional with/without brake – as well as with plain shaft or feather key



Typical application areas

- Handling systems, automatic equipping and assembly machines
- Packaging and labeling machines
- Metal forming machines
- Printing machines
- Winders and unwinders

SIMOTICS S-1FL6 servomotors – an overview

SIMOTICS S-1FL6	Standstill torque*	Rated speed*	Rated power*
LI – Low Inertia	0.16 – 6.37 Nm	up to 5000 rpm	0.05 – 2.0 kW
HI – High Inertia	1.27 – 33.4 Nm	up to 3000 rpm	0.4 – 7.0 kW

* depending on the version and type

**Highlights
SINAMICS S210 and
SIMOTICS S-1FK2**

- Two versions with different moments of inertia: Compact and High Dynamic
- High efficiency and 300 percent overload capability
- With either multiturn absolute or incremental encoders
- Extremely simple to commission with web server, motor parameters are automatically read in – and the drive system can be perfectly optimized using the One Button Tuning function
- One Cable Connection (OCC) to connect the motor to the converter

SIMOTICS S-1FK2 and SINAMICS S210 – perfect interaction to address high requirements

SIMOTICS S-1FK2 motors have been specifically developed for use with SINAMICS S210 converters, to create a servo drive system with five power classes from 50 up to 750 Watts. This means that low loads can be moved with an extremely high dynamic response – and high loads can be positioned with a high degree of precision.

Motors are connected to the converters through an innovative connection system (One Cable Connection – OCC) with quick release; this combines power conductors, encoder signal and brake in one thin cable along with a single, compact plug connector that can be rotated. This simplifies installation and increases the ruggedness of the drives.



Typical application areas

- Packaging machines and filling systems
- Feeding, removing, mounting and stacking systems
- Wood and ceramic processing
- Digital printing machines



SIMOTICS S-1FK2 servomotors – an overview

SIMOTICS S-1FK2	Standstill torque*	Rated speed*	Rated power*
CT – Compact	0.64 – 1.27 Nm	3000 rpm	0.2 – 0.4 kW
HD – High Dynamic	0.16 – 2.4 Nm	3000 rpm	0.05 – 0.75 kW

* depending on the version and type

Main motors with outstanding performance up to 40,000 rpm

Our SIMOTICS main motors have been designed to address the increasing demands associated with state-of-the-art plant and machine construction. Available in rugged induction or synchronous versions, they set themselves apart due to their short rise times – and can even handle extreme load cycles with high speed, torque and positioning precision.

SIMOTICS M-1PH8 – modular power houses

The sophisticated modular design offers various degrees of protection and cooling methods – as well as several options to electrically and mechanically integrate the main motor. SIMOTICS M-1PH8 **induction motors** are the ideal choice for applications where – in addition to the higher drive power – the primary focus is on precise, smooth running characteristics and precise controllability of the axes. Further, you can operate them together with SINAMICS G120 converters which, when compared to standard main motors, extends the applications that they can realize as a result of the wider speed range. This allows them to address new, more compact machine concepts. When the focus is on high rated torques, our compact SIMOTICS M-1PH8 **synchronous motors** have unbeatable smooth running characteristics.



Typical SIMOTICS M-1PH8 induction motor applications

- Machine tool spindles
- Paper and printing machines, winders
- Hoisting equipment and cranes
- Wood, glass, ceramics and stone processing machines
- Test stands
- Presses
- Plastics and textile machines
- Wire-drawing machines

SIMOTICS M-1PH8 induction and synchronous main motors – an overview

	Standstill torque*	Rated speed*	Max. speed*	Rated power*
SIMOTICS M-1PH8 Induction	2.9 – 12,435 Nm	400 – 10,000 rpm	up to 24,000 rpm	2.8 – 1340 kW
SIMOTICS M-1PH8 Synchronous	94 – approx. 1650 Nm	700 – 3600 rpm	up to 4500 rpm	15 – 310 kW

* depending on the version and type

Highlights

SIMOTICS M-1PH8

- Extended power range from 2.8 kW to 1340 kW
- Flexible configuration options
 - Induction or synchronous motor versions
 - Force-ventilated or water-cooled
 - Solid or hollow shaft
 - Wide range of bearing concepts
 - Various encoder types for closed-loop speed control and high-precision positioning
- High smooth running characteristics and ruggedness thanks to the outstanding true running and low vibration severity at maximum speeds of up to 24,000 rpm
- High dynamic performance and short accelerating times
- Winding switchover (star/delta)
- Simple and flexible connection system
- Commissioning using the electronic rating plate via digital DRIVE-CLiQ interface

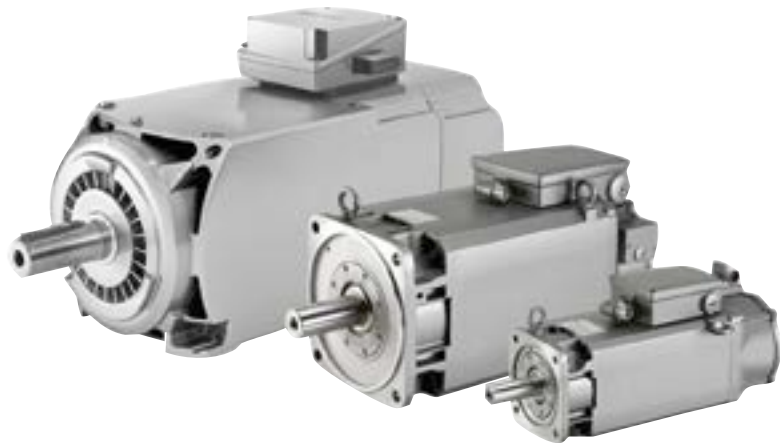

Whether synchronous or induction – it is always SIMOTICS!

SIMOTICS M-1PH8 **induction motors** are the ideal choice for applications where – in addition to the higher drive power – the primary focus is on precise, smooth running characteristics and precise controllability of the axes. Further, you can operate them together with SINAMICS G120 converters which, when compared to standard main motors, extends the applications that they can realize as a result of the wider speed range. This allows them to address new, more compact machine concepts.

When the focus is on high rated torques, our compact SIMOTICS M-1PH8 **synchronous motors** have unbeatable smooth running operation. With a wide range of options, they can be flexibly adapted to every application, and are available with forced ventilation as well as with water cooling. This is a typical requirement for machine tools and printing machines – but also for servo presses and rod mills, etc.

Typical SIMOTICS M-1PH8 synchronous motor applications

- Machine tools
- Servo presses and cross-cutters
- Printing machines
- Extruders, calenders and rubber injection systems
- Foil machines and systems producing non-woven fibers
- Rod mills and cable stranding machines
- Coiler and winder drives





SIMOTICS M-1FE – has enough space in any spindle

SIMOTICS M-1FE synchronous built-in motors are especially compact main spindle motors with a very high dynamic performance that have been specifically designed for machine tool applications. They set themselves apart as a result of their very high machining quality, short acceleration times, highest precision and smooth running characteristics.

Versions are available for very high torque utilization (High Torque) – or high maximum speeds (High Speed) to address specific applications. The mechanical motor power is directly transferred to the spindle without any mechanical transmission elements. The rotor and stator are ready to be installed and are water-cooled.

Highlights

SIMOTICS M-1FE

- Compact design as mechanical components can be eliminated
- Short accelerating and braking times
- High degree of stiffness for milling spindles based on the large inner rotor bores (and therefore large shaft diameter)

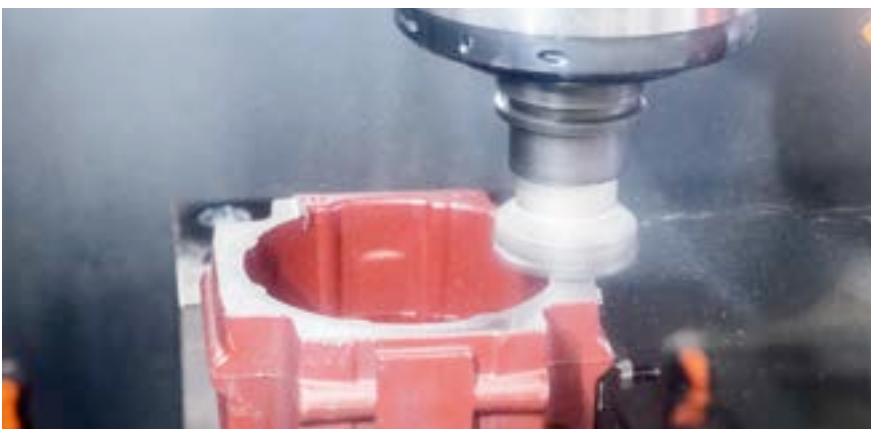

Typical application areas

- Turning spindles
- Grinding spindles
- Milling spindles

SIMOTICS M-1FE main motors – an overview

SIMOTICS M-1FE	Series	Rated torque*	Max. speed*	Rated power*
High Speed	M-1FE1	up to 300 Nm	up to 40,000 rpm	6.5 – 94 kW
High Torque	M-1FE1, M-1FE2	up to 1530 Nm	up to 20.000 rpm	4 – 159 kW

* depending on the version and type

The benchmark for directly driving linear axes

SIMOTICS linear motors set benchmarks when it comes to accuracy, precision and cost effectiveness of applications involving linear motion. Contrary to conventional drive solutions, they do not require any mechanical transmission elements – which simplifies the design of your machines and optimizes their availability.

Highlights SIMOTICS L-1FN3

- Highest precision linear motion with high dynamic performance
- Enormous force density in a compact design
- Highest traversing velocities for all applications
- Highest precision when using suitable measuring systems
- High energy efficiency
- Large air gap, therefore extremely rugged against external influences
- Wide range of options depending on the application profile
- Simple mounting and installation
- Wear-free drive components
- Low lifecycle costs of machines

SIMOTICS L-1FN3 – the modular industry sector standard

Water-cooled SIMOTICS L-1FN3 motors were specifically developed for machine tool applications – and have been the proven standard for linear motion for many years. The modular principle provides you with a comprehensive range of motor versions that are almost wear-free and therefore low-maintenance. They are available in several different widths and up to five different lengths – as well as several winding types.

The motors are harmonized and coordinated for operation with SINAMICS S120 converters. A wide range of accessories is available to further optimize the high degree of ruggedness and thermal encapsulation.

When it comes to using direct drives in machine tool and production machines, Siemens has many years of experience and a wealth of specific know-how. Based on all of this experience and know-how, we are more than willing to support you in reliably and quickly implementing your development goals. Simply contact us:

 motor.support.motioncontrol@siemens.com

SIMOTICS L-1FN3 linear motors – an overview

SIMOTICS L-1FN3	Feed force*	Velocity*	Overload capability*
1FN3 peak load	up to 20,700 N	up to 836 m/min	up to 2.75 x F _N
1FN3 continuous load	up to 17,610 N	up to 435 m/min	up to 1.7 x F _N

* depending on the version and type

- 1** Primary section
- 2** Precision cooler
- 3** Secondary section
- 4** Secondary section cover
- 5** Cooling profile
- 6** Power cooler
- 7** Connection cover for separate power and signal cables
- 8** Combination adapter



Typical application areas

- Milling, turning and grinding machines
- Laser machining centers
- Handling systems
- Production machines
- Oscillators
- Test setups

Always providing the right spin at precisely the right time

Whether for machine tools, extruder worms or paper rolls – SIMOTICS slow speed permanent-magnet torque motors represent an attractive solution for driving all rotary axis types. They can be completely integrated in machines, without requiring mechanical transmission elements. This reduces the space required, provides maximum flexibility when integrating the motors, minimizes maintenance costs and maximizes availability.

Further, the direct mechanical connection results in an increased dynamic performance and control quality in the overall system and ensures a high torque at the optimum speed with high precision – resulting in highly productive machines. Depending on the application, you have the choice between two motor types.

SIMOTICS torque motors – highest precision for rotary axes

The extremely compact, water-cooled **SIMOTICS T-1FW3 complete torque motors** are flanged to the machine using torque arms specifically developed for the purpose. An optional clamping element makes it easier to couple the rotor to the machine shaft.

The pre-installed mounting set includes the torque arm, clamping element and centering sleeve (only for hollow shafts) – making it simple and safe to establish a connection to the motor. This creates a perfectly stiff drive train that can be optimally controlled.



Highlights SIMOTICS torque motors

- Highest precision, power and dynamic performance
- Various application-specific versions
- Direct controllability; no elasticities in the drive train
- Low space requirement and simplified maintenance as the motor can be directly integrated into the machine structure without having to use mechanical transmission elements
- High number of poles for high torques at low speeds
- Short acceleration times and very high smooth running characteristics
- High degree of efficiency
- High degree of availability



SIMOTICS T-1FW3

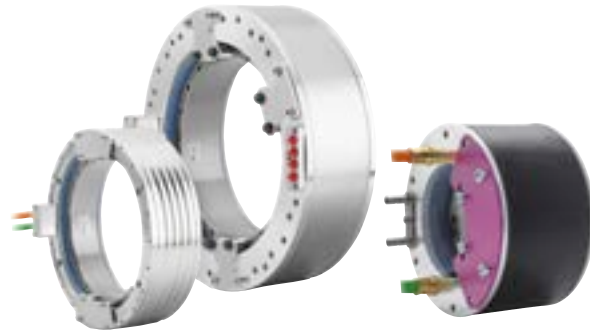

SIMOTICS T-1FW6

For **SIMOTICS T-1FW6 built-in torque motors**, stator and rotor are supplied as components and are directly integrated in the machine itself. They are available with jacket as well as with integrated cooling. Further, the motors operate without any mechanical transmission elements – e.g. coupling and gearbox – and require significantly less space than conventional drives. The compact design and low number of installed parts reduce the number of interfaces, maintenance costs and stock inventory costs – thus minimizing machine failures.

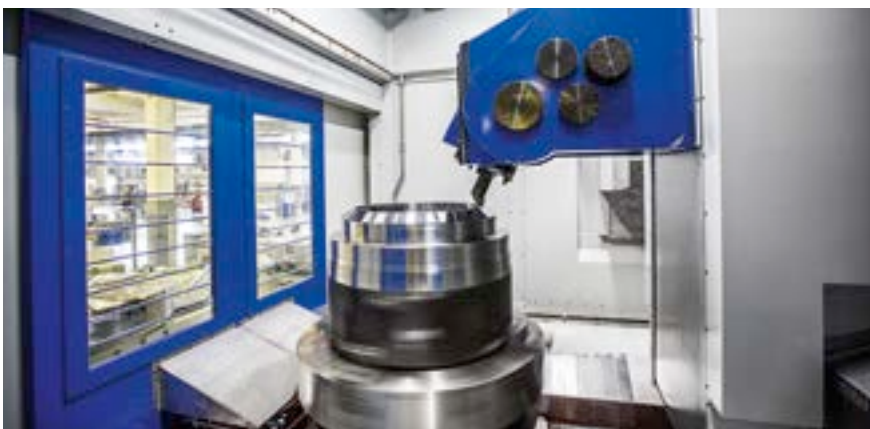

Typical SIMOTICS T-1FW3 application areas

- Fiber and paper industry
- Plastics-processing industry
- Handling and assembly systems

Typical SIMOTICS T-1FW6 application areas

- Rotary indexing machines
- Rotary indexing tables and partial machines
- Rotary axes
(A/B/C for 5-axis machining centers)
- Workpiece spindles
- Roll and cylinder drives
- Test stands

SIMOTICS torque motors – an overview

SIMOTICS T	Rated torque*	Rated speed*	Maximum speed*	Maximum torque
T-1FW3 complete torque motor	up to 7,000 Nm	up to 1,200 rpm	up to 1,800 rpm	11,000 Nm
T-1FW6 built-in torque motor	up to 5,760 Nm	up to 940 rpm	up to 1,500 rpm	10,900 Nm

* depending on the version and type

MOTION-CONNECT connection system – the simple, fast and reliable connection

With MOTION-CONNECT, Siemens offers a reliable, high-quality and efficient system cabling for your motion control systems. You profit from higher availability of your plant and system and from an innovative connection system, which is significantly faster and simpler to connect than conventional systems.

Always the optimum connection

- One Cable Connection (OCC): between the motor and converter
- MOTION-CONNECT 500: cost-effective product for predominantly fixed cable routing
- MOTION-CONNECT 800PLUS: for a high dynamic performance – a performance product for use in drag chains with increased mechanical requirements up to 5 g or long traversing distances up to 50 m
- SPEED-CONNECT: fast, rugged and reliable connection using robust round quick release connectors
- DRIVE-CLiQ: high-quality shielded cables with RJ45 metal connector or compact and rugged M12 connector for connecting direct measuring systems

Highlights MOTION-CONNECT

- The optimum connection between SINAMICS converters and SIMOTICS motors; plug & play based on system-tested original components
- Prefabricated cables with rugged IP67 connectors
- Cables prefabricated with decimeter accuracy
- Large selection based on the finely graduated cross-sections from 1.5 up to 120 mm²
- Consistent quality management and a comprehensive test program
- Highest plant/system availability and high EMC quality using a 360° shield connection

Technical overview of MOTION-CONNECT

Product	Type	Max. traversing velocity [m/min]	Max. bending operations* [millions]	Max. acceleration* [m/s ²]	Max. traversing distance* [m]
MC500	Power cable	0 – 30	0–0.1	0 – 2	0–5
	Signal cable	0 – 30	0–0.1	0 – 2	0–5
MC800 PLUS	Power cable (up to 16 mm ²) and signal cable	0 – 300	0 – 10	0 – 50	0 – 50
	Power cable (25 to ... 50 mm ²)	0 – 300	0 – 10	0 – 50	0 – 50

* mechanically tested

DRIVE-CLiQ – for plug & play commissioning and increased transparency when it comes to monitoring the motor

As digital interface for SIMOTICS motors, DRIVE-CLiQ uses an Ethernet-based format for fast encoder and motor data transfer between the motor and converter. The motor and encoder electronic type plate are identified in the SINAMICS drive system via this connection – thus facilitating automatic parameterization. This results in fast and simple commissioning.

Further, DRIVE-CLiQ offers some significant advantages while the motor is operational. Transferring actual operating data allows plants and machines to be more transparently monitored.

Highlights DRIVE-CLiQ

- High-performance system interface for the SINAMICS drive system
- Encoders from various manufacturers can be connected
- Integrated safety functions are supported (SINAMICS Safety Integrated)
- Auto configuration based on electronic rating plates
- Simple standard cabling for all encoder types
- Hubs are used to reduce cable connections
- Low engineering costs
- Simple and fast diagnostics of the measuring system

Configuration schematic SINAMICS S120 booksize group

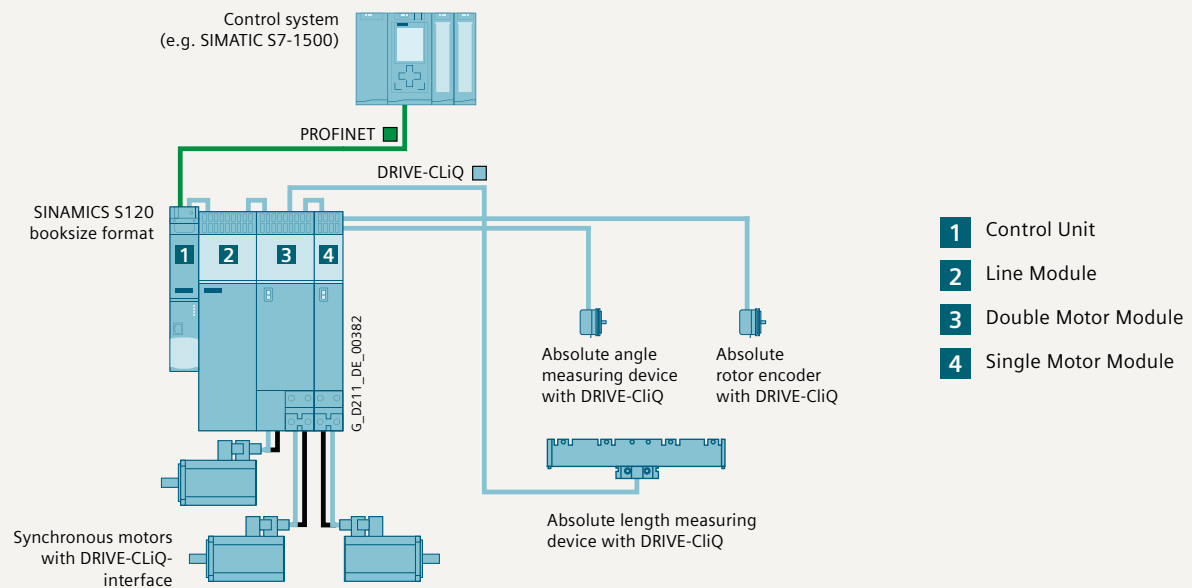

SIZER, DT Configurator and CAD CREATOR: drive engineering – simple and fast

With Siemens, you can obtain the optimum motor solution in a convenient and user-friendly way – thanks to the efficient and high-performance DT Configurator and CAD CREATOR tools for engineering and design.



 [siemens.com/sizer](https://www.siemens.com/sizer)
[siemens.com/dt-configurator](https://www.siemens.com/dt-configurator)
[siemens.com/cad-creator](https://www.siemens.com/cad-creator)

Efficient motor selection and dimensioning: SIZER engineering software

The SIZER engineering software supports you when engineering a complete drive system, including options, accessories and connection systems. SIZER allows you to simply handle single-motor drives up to complex multi-axis drives. Starting from the application, a motor Wizard supports you step by step when dimensioning the motor. The advantage of this approach is that SIZER not only provides a list of all the components with the various ordering data, but also allows motor data to be simply imported into the CAD CREATOR.

Selecting and configuring using the Drive Technology Configurator

The Drive Technology Configurator (DT Configurator) supports you when selecting the optimum products for your application – from motors through converters up to the relevant options.





Comprehensive documentation – from data sheets through operating instructions up to 2D/3D dimension drawings and certificates – can also be called up. The components that you selected can be directly ordered by transferring them into the Industry Mall shopping cart.

Integrated: Mechanical design based on CAD CREATOR

Technical data, dimension drawings and CAD motor data can be quickly and simply generated using CAD CREATOR. The data can be easily transferred into the system documentation and used for the mechanical design.

CAD CREATOR is included in the scope of supply of the SIZER engineering software.

SIMOTICS motion control motors – an overview

	SIMOTICS servomotors			Servo drive systems	
					
Motor types	SIMOTICS S-1FK7	SIMOTICS S-1FT7	SIMOTICS S-1FG1	SIMOTICS S-1FL6	SIMOTICS S-1FK2
Cooling methods	Natural cooling, forced ventilation	Natural cooling, force-ventilated, water cooling	Natural cooling	Natural cooling	Natural cooling
Shaft height	20 ... 100	36 ... 132	Frame size 29 ...109	20 ... 90	20, 30, 40
Degree of protection	IP64 to IP65	IP64 to IP67	IP65	IP65	IP64 to IP65
Rated speed / velocity	2000 ... 6000 rpm	1500 ... 6000 rpm	13 ... 1279 rpm	2000 ... 5000 rpm	3000 rpm
Rated power	0.05 ... 8.17 kW	0.88 ... 45.5 kW	0.5 ... 1.8 kW	0.05 ... 7.0 kW	0.05 ... 0.75 kW
Rated Nm torque / force	0.08 ... 37 Nm	1.4 ... 250 Nm	Dependent on the geared motor up to 3070 Nm	0.16 ... 33.4 Nm	0.16 ... 2.4 Nm
Encoder	Single and multturn absolute encoder, incremental encoder, resolver	Single and multturn absolute encoder, incremental encoder	Single and multturn absolute encoder, resolvers	Single and multturn absolute encoder, incremental encoders	Single and multturn absolute encoder
Holding brake as option	Yes	Yes	Yes	Yes	Yes
Typical applications	Applications with high up to very high demands on the dynamic performance and precision, e.g. robots and handling systems, wood, glass, ceramic and stone processing, packaging, digital printing, plastics and textile machines and in the machine tool sector		In applications such as palletizers, storage and retrieval machines with hoisting, travel and fork drives, dosing pumps and actuator drives	Handling systems, automatic equipping and assembly machines, packaging and labeling machines, metal forming machines, printing machines, winders and unwinders	Applications with high up to very high demands on the dynamic performance and precision, e.g. robots and handling systems, wood, glass, ceramic and stone processing, packaging, digital printing, plastics and textile machines and in the machine tool sector
Drive systems	SINAMICS S120	SINAMICS S120	SINAMICS S120	SINAMICS V90	SINAMICS S210
Catalog*)	D21.4, NC62, D31.1	D21.4, NC62, D31.1	D41	D33	D32

*) D21.4: SINAMICS S120 and SIMOTICS
D31.1: SINAMICS converters for single-axis drives / built-in units
D32: SINAMICS S210 servo drive systems

*) D33: SINAMICS V90 basis servo drive systems
D41: SIMOTICS S-1FG1 servo geared motors
NC62: SINUMERIK 840 equipment for machine tools

SIMOTICS main motors		SIMOTICS linear motors	SIMOTICS torque motors	
				
SIMOTICS M-1PH8	SIMOTICS M-1FE1, M-1FE2	SIMOTICS L-1FN3	SIMOTICS T-1FW3	SIMOTICS T-1FW6
Force-ventilated, open-circuit-cooled, water-cooled	Water cooling	Water cooling	Water cooling	Water cooling, natural cooling
80 ... 355	40 ... 180	–	150 ... 280	159 ... 730 (outer stator diameter)
IP23, IP55, IP65	IP00	IP65	IP54/IP55	IP23
400 ... 10,000 rpm	500 ... 25,000 rpm	Max. velocity at rated force (feed force F_N): up to 836 m/min	150 ... 1200 rpm	38 ... 940 rpm
2.8 ... 1340 kW	4.0 ... 159 kW	1.7 ... 81.9 kW	2.8 ... 380 kW	1.7 ... 54.1 kW
2.9 ... 12,435 Nm	up to 1530 Nm	Rated force (feed force F_N): 150 ... 10,375 N	100 ... 7000 Nm	10 ... 5760 Nm
Multiturn encoder, incremental encoder	External encoder required	External encoder required	Singleturn, multiturn and absolute encoders, incremental encoders, resolvers	External encoder required
Yes	–	–	–	–
High-precision and high-dynamic rotary axes, e.g. main drives in presses, printing machines, roll drives and winders in foil machines and other converting applications, extruders, main spindle drives in machine tools	Motor spindles in machine tools, e.g. turning, grinding and milling spindles	Linear axes with the highest requirements regarding dynamic response and precision – e.g. machining centers, grinding and out-of-center turning machines, laser and waterjet cutters, handling gantries and linked/cascaded systems	Applications with high up to very high requirements on the torque and precision, e.g. extruders, injection molding machines, roll drives in foil-drawing machines, paper machines, winders, servo presses	Applications with high up to very high requirements on the torque and precision, e.g. rolls and winders, rotary indexing tables, rotary cyclic machines, swiveling axes, test stands
SINAMICS S120, G120	SINAMICS S120	SINAMICS S120	SINAMICS S120	SINAMICS S120
D21.4, NC62, D31.1	NC62	D21.4, NC62	D21.4	D21.4, NC62

Mechatronic Support: faster to the machine – faster to market

With Mechatronic Support, Siemens can offer you the ideal basis to significantly optimize the productivity and precision of your machine – and this, already in the design phase. Based on this approach, new machine concepts can be virtually compared with one another, modified and optimized – without having to build a prototype.

A clever alternative to trial and error

With Mechatronic Support, Siemens offers you an intelligent alternative to developing costly prototypes. Using virtual prototyping, already in the draft phase, all mechanical, electronic and IT systems can be modeled and optimized regarding their functionality. The machine is produced without first having to build a prototype.

Siemens – your partner for machine development

- Comparison and assessment of machine concepts regarding static and dynamic precision, control loop dynamics, stiffness
- Mechatronic model building and machine simulation (finite element techniques)
- Computer-based optimization of machine structures
- Optimum dimensioning and selection of all motor and control loop components
- Commissioning and control loop optimization
- Analysis and optimization of existing tool and production machines locally on site
- Shorter development times – faster to market
- Development objectives are reliably reached
- Risk-free testing of new machine concepts
- Higher quality and productivity from the word go

 [siemens.com/motioncontrol/mechatronic](https://www.siemens.com/motioncontrol/mechatronic)

Classic approach, mechanical design



Virtual prototyping with Mechatronic Support

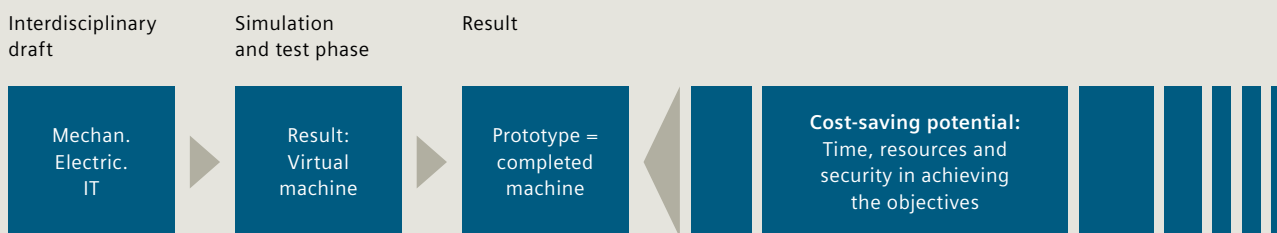

Experience more:

[siemens.com/motion-control-motors](https://www.siemens.com/motion-control-motors)

Follow us on:

www.twitter.com/siemensindustry

www.youtube.com/siemens

Published by
Siemens AG 2019

Digital Industries
Motion Control
P.O. Box 3180
91050 Erlangen, Germany

For the U.S. published by
Siemens Industry Inc.
100 Technology Drive
Alpharetta, GA 30005
United States

Article No. DFMC-B10034-00-7600
Printed in Germany
4215 WS 0919 PDF

Subject to changes and errors.

The information given in this document only contains general descriptions and/or performance features which may not always specifically reflect those described, or which may undergo modification in the course of further development of the products. The required performance features are only binding if they have been expressly agreed upon in the form of a written contract.

For the secure operation of products and solutions from Siemens it is necessary to take suitable protective measures (e.g. a cell protection concept), and to integrate every component into an integrated and holistic industrial security concept that corresponds to state-of-the-art technology. When so doing, products from other manufacturers should be taken into account. For more information about Industrial Security, visit <http://www.siemens.com/industrialsecurity>