



WHITE PAPER

Dimensioning and protection of **control circuits according to UL**

When switching equipment is used in the USA, it must comply with US standards relating to safety and fire safety. The proper and standardized configuration of the switchgear is of central importance since, depending on the use of approved components, on-site inspection can thereby be considerably simplified.

The essential requirements for the dimensioning and protection of control circuits are described in the following.

SIEMENS

Content

Switching equipment for use in the USA	3
NEC - National Electrical Code	3
UL - Underwriters Laboratories	3
Relevant standards for switchgear construction	3
Control circuits	4
NEC Class 1 Control Circuit (UL 508A § 2.6) = Unlimited general control circuit	4
Class 2 Control Circuit (UL 508A § 2.7) = Control circuit with limited energy	4
Low Voltage Limited Energy Circuit (UL 508A § 2.32) = LVLEC	8
Requirements for a power supply according to UL	9
Requirements for the single-phase primary connection of a power supply	9
Requirements for the three-phase primary connection of a power supply	9
Requirements for the secondary connection of a power supply (SITOP as an example)	10
Portfolio of SITOP power supplies and add-on modules for control circuits according to NEC Class 2	11
Abbreviations	13
Further information	13

Switching equipment for use in the USA

Each piece of switching equipment is examined in the USA by the AHJ Inspector (Authority Having Jurisdiction) and released for the intended operation and use according to the relevant standards. However, the following distinctions must be taken into consideration.

NEC – National Electrical Code

The NEC is the only legally binding standard for electrical equipment in the USA. It is issued by the National Fire Protection Association (NFPA). This standard is the only one which has a legal status and is thus recognized by governmental authorities similar to a law. The AHJ inspector checks and approves acceptance based on this standard.

UL – Underwriters Laboratories

UL is an independent testing organization that tests and certifies products for their safety. It tests products, components, materials and systems to ensure they meet specific requirements. After testing, these products may bear the UL mark as long as they comply with the prescribed standards. UL has the privilege of being able to independently create recognized product test standards. This means that the other approved testing organizations must perform testing according to the UL product test standards.

Relevant standards for switchgear construction

The relevant requirements for devices used in control cabinets are contained in the application standard, UL 508A "Industrial Control Panels". For successful acceptance of the switching equipment, the manufacturer of the control cabinets for export to the USA must consider the following: When UL-certified components are used, a distinction must be made between "UL-listed" components, the use of which is approved by testing standards, and "UL-recognized" components with limited conditions ("conditions of acceptability") for case-by-case use in an overall system.

Control circuits

A control circuit is defined as a circuit that supplies only signals to a controller (e.g. PLC, relay). It has no main circuit loads (e.g. motors, heaters).

NEC Class 1 Control Circuit (UL 508A § 2.6) = Unlimited general control circuit

"Class 1 Control Circuits" may be connected directly to a branch (load feeder), but also from the feeder (distribution circuit). They can also be connected directly to a separate feeder or to the out-put side of a transformer or power supply. The maximum voltage is 600 V. The maximum current (power) is unlimited (usually maximum 15 A).

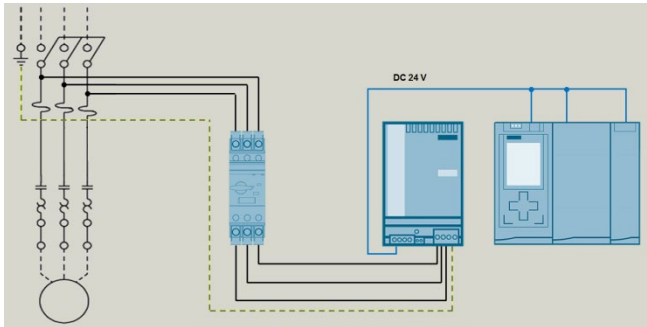

Class 1 Control Circuit



Class 2 Control Circuit (UL 508A § 2.7) = Control circuit with limited energy

These control circuits are built using specially approved power supply units that are equipped with a special "OUTPUT: NEC Class 2". These power supplies are characterized by the fact that the output power is limited to 100 VA even in the event of a fault. Components in the control circuit with the approval "... for use with Class 2 only..." may only be supplied by these Class 2 power supplies. The advantage for the user is that UL-unlisted components may also be used in the "NEC Class 2 circuit" because it is not necessary for the AHJ to accept the components in this secure control circuit. When the control cabinet is accepted, the AHJ takes the information from the UL test report of the power supply units: "The following models have been additionally investigated for NEC Class 2 output and comply with its requirements". An NEC Class 2 control circuit may be routed out of the control cabinet if it is specially marked on the terminals and routed separately from other circuits. There are various options for realizing NEC Class 2 control circuits. The classic variant is the use of NEC Class 2 power supplies.

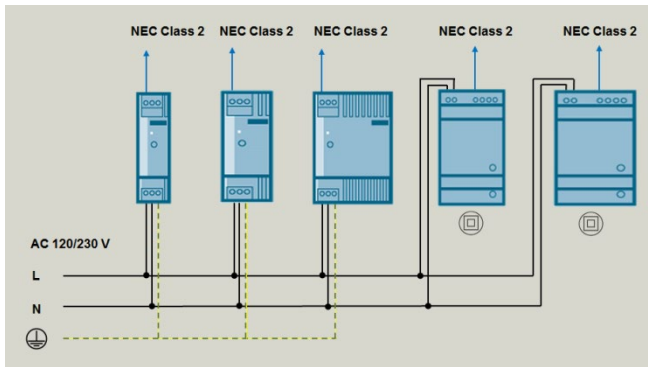

Several NEC Class 2 control circuits each supply via a separate NEC Class 2 power supply.

Another possibility for building an NEC Class 2 control circuit is to use specially tested Class 2 SITOP redundancy modules with power outputs limited to 100 VA. The great advantage of this solution is that a central power supply can be used. By using these redundancy modules, it is possible to create a distributed configuration of the NEC Class 2 outputs based on the requirement.

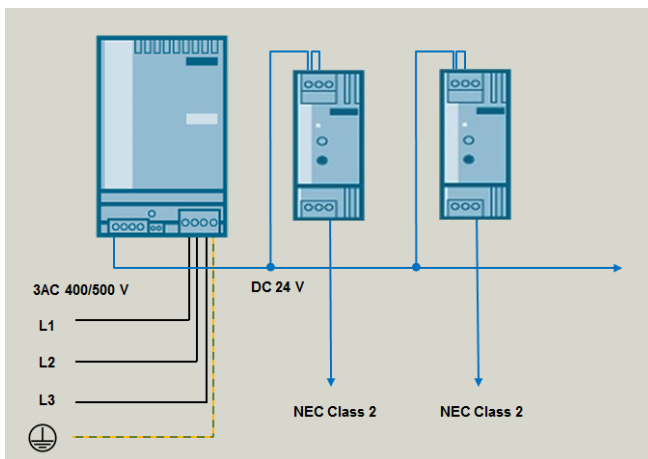

NEC Class 2 control circuits each supply from a central power supply via an NEC Class 2 redundancy module (without redundancy)

In order to ensure higher availability of the systems, two central power supplies can be used thereby enabling a redundant supply.

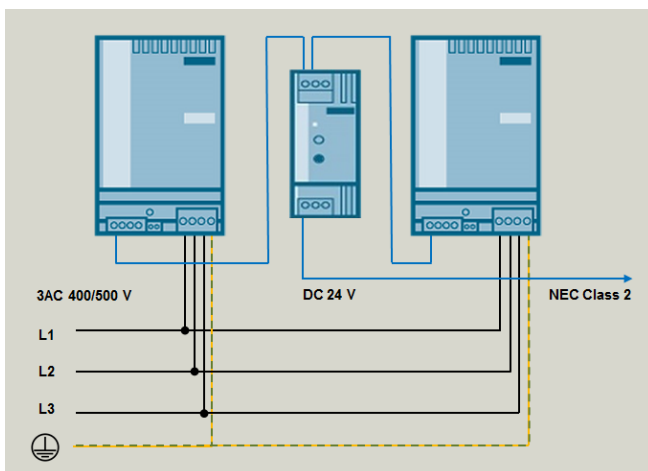

A redundant NEC Class 2 control circuit supplies power from two power supplies via an NEC Class 2 redundancy module

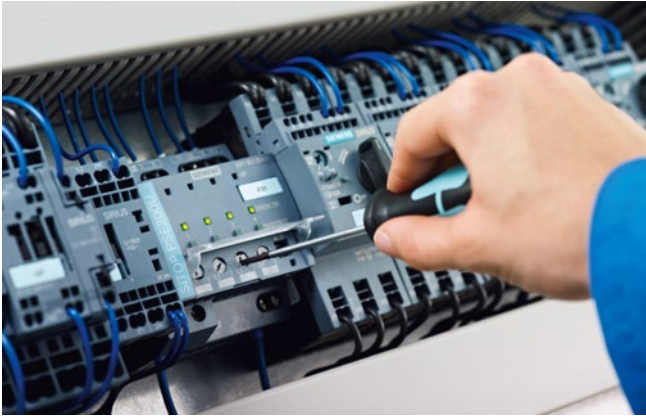

NEC Class 2 load feeders can also be implemented with special selectivity modules. In this case, a central 24 V DC power supply also feeds one or more selectivity modules, the output channels of which are limited to 100 VA of power. The advantage of this design is that it allows the realization of both the selectivity of the output channels as well as the power limitation according to NEC Class 2.

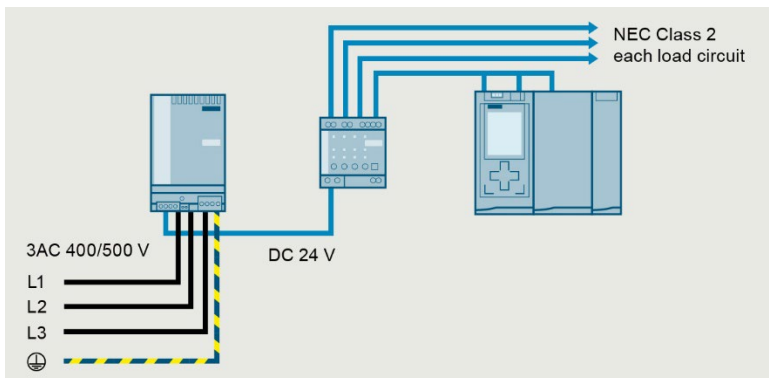

Several NEC Class 2 control circuits each supplied via a separate output of an NEC Class 2 selectivity module

The NEC Class 2 selectivity module is specially designed to protect 24 V DC individual load circuits supplied by switched-mode power supplies. The individual setting of the tripping current enables optimum adaptation to the respective control circuit. The configuration work is minimal since the cut-off characteristic always guarantees reliable tripping – even with high line impedances. The output power is also limited to a maximum of 100 VA per channel even with a short-circuit.

The NEC Class 2 selectivity module also has another important function: The electronics continuously monitor the 24 V DC input voltage. As soon as the 24 V DC threatens to fail, the path with a higher current than the set current is disconnected immediately. All other circuits continue to be supplied without interruption. Even PLCs, which can only bridge power failures for a few milliseconds, continue to run without problems.

SITOP PSE200U NEC Class 2 Shutdown characteristic

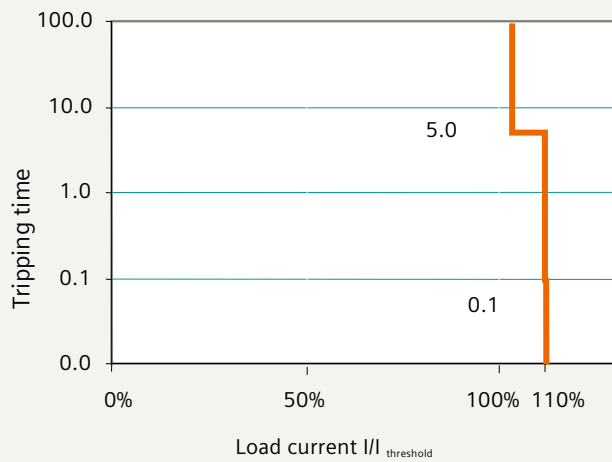

Response with current requirements per output circuit ...

- From 0 A up to set value ($I/I_{\text{threshold}} = 100\%$)
→ no shutdown
- From 100 % up to 110 % of set value
→ shutdown after approx. 5 s
- Above 110 % of set value
→ current limiting to approx. 110 % for typ. 100 ms, then shutdown
- Above set value with simultaneous collapse of supply voltage below 20 V DC
→ immediate shutdown

Because this overcurrent protection was successfully tested according to UL and thus accepted, no additional short-circuit protection devices need to be installed in the four NEC Class 2 circuits when using SITOP NEC Class 2 selectivity modules.



With the same functions as the selectivity module, the NEC Class 2 expansion module for the SITOP PSU8600 power supply system also fulfills additional requirements. It has 8 outputs with a rated output current of 2.5 A at 24 volts. In addition to the typical control voltage of 24 V, each output can be adjusted between 4 and 28 volts, thus supplying loads with other rated voltages while complying with NEC Class 2. The power supply system features an Ethernet/PROFINET interface which makes a wide range of settings and diagnostics possible, including those for the NEC Class 2 outputs.

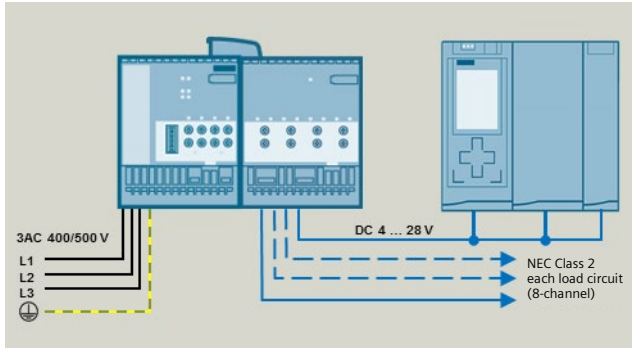

The 8-channel CNX8600 expansion module supplied the NEC Class 2 feeders with different voltages ranging from 4 to 28 V DC.

Low Voltage Limited Energy Circuit (UL 508A § 2.32) = LVLEC

An LVLEC control circuit has "protected" low voltage of an effective maximum of 30 V AC or a maximum of 42.4 V DC. Unlike the NEC Class 2 circuit, no specially tested power supply units are required; protection is provided only by the "100 VA rule". With a voltage of 0 to 20 V, this is a maximum of 5 A. For voltages above 20 V, this is a maximum of 100 VA (e.g., at 24 V, $100 \text{ VA} / 24 \text{ V} = 4 \text{ A}$).

The LVLEC control circuit must not exit the control cabinet.

Non-UL listed components may also be used for supplying an LVLEC control circuit. Devices which are used entirely in an LVLEC control circuit do not need to be inspected by the AHJ. Additional short circuit protection devices also don't need to be installed in the four-channel circuits when using SITOP LVLEC selectivity modules.

Several LVLEC control circuits each supply via a separate output channel of a selectivity module.

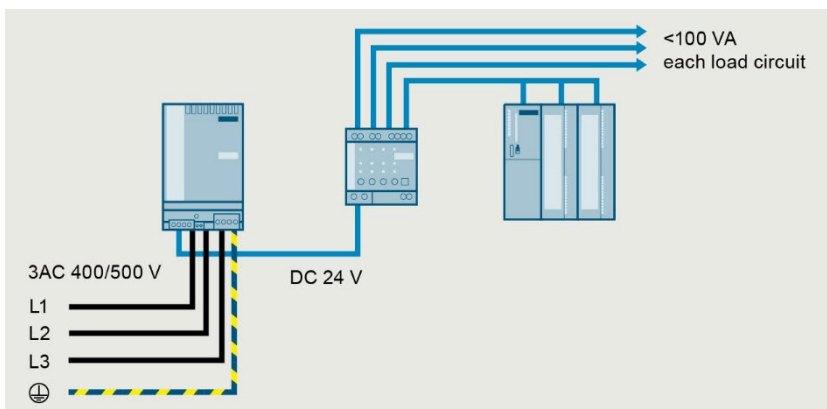

Requirements for a power supply according to UL

Switching power supplies used in control circuits also require special protection for connection to the primary supply network, depending on the application.

Requirements for the single-phase primary connection of a power supply

According to UL 508A, each control circuit must be primary fused. Since a fuse for the device protection is installed in most single-phase power supplies, the use of an additional fuse can be omitted if the N conductor is grounded. In this case, the cable must be installed short-circuit proof. The L conductor must be protected without grounding the N conductor.

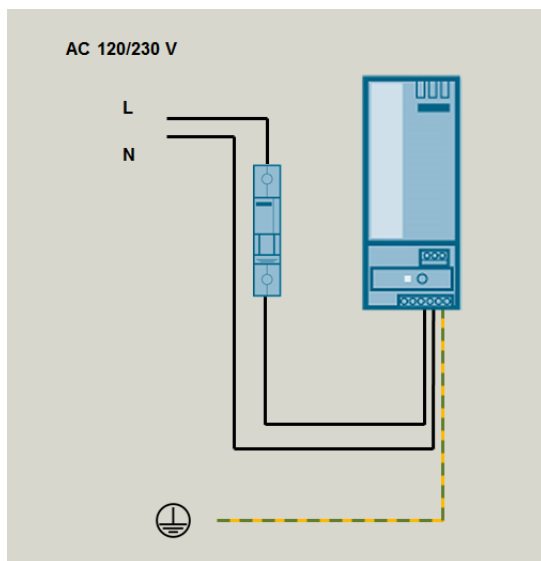

Primary connection of a single-phase power supply without grounding the N conductor.

Requirements for the three-phase primary connection of a power supply

No fuses are normally installed for device protection in three-phase power supplies. The protection is provided using upstream fuse elements, which are selected depending on whether the tap is made before or after the branch protection. According to UL 508A, only fuses and inverse-time circuit breakers (tested according to UL 489) are permitted when the control circuit branches off from the feeder. It should be noted here that when a fuse is used, its failure can damage the power supply due to the unbalanced load. It is therefore always recommended to use a 3-phase inverse-time circuit breaker. 3-pole coupled circuit breakers of the 5SJ4 series (UL 489) or circuit breakers of the 3RV27 series (UL 489) can be used for this purpose. The type of mains and the required SCCR value at the feed-in point of the control cabinet must be taken into account.

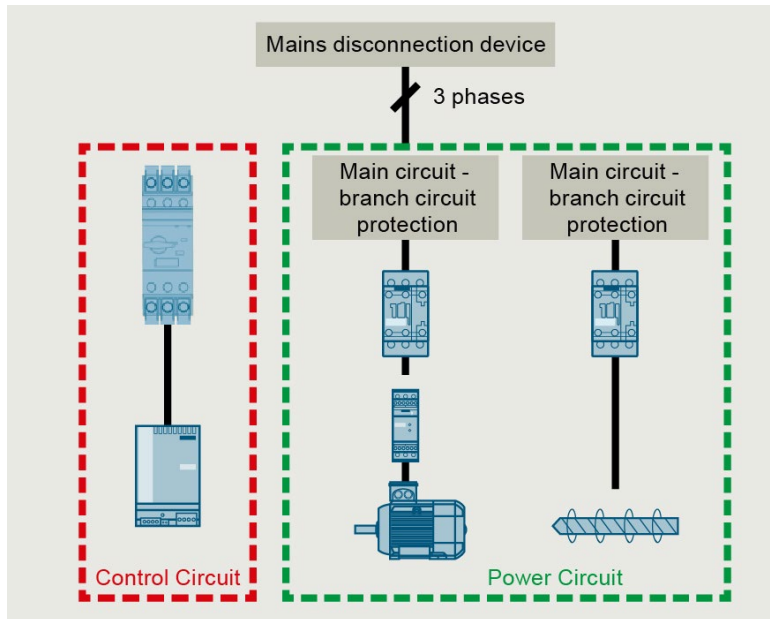

Connection of a three-phase power supply.

Requirements for the secondary connection of a power supply (SITOP as an example)

Class 1 Control Circuit (UL 508A § 2.6) = Unlimited general control circuit

- All SITOP power supplies may be used.
- The fuses are protected according to UL 508A Table 42.2 (Sizing of primary and secondary overcurrent protection of a control transformer)



Class 2 Control Circuit (UL 508A § 2.7) = Control circuit with limited energy

- Use of SITOP power supplies with the marking "OUTPUT NEC Class 2"
- The fuses are protected according to UL 508A Table 42.2 (Sizing of primary and secondary overcurrent protection of a control transformer)
- Use of a selectivity module PSE200U NEC Class 2 QVRQ2.E328600 (UL 2367) which is supplied by a random SITOP power supply unit

LVLEC – Low Voltage Limited Energy Circuit

- Protection according to the 100 VA rule (special safety fuse or circuit breaker or selectivity modules SITOP PSE200U NMTR.E197259)

Portfolio of SITOP power supplies and add-on modules for control circuits according to NEC Class 2

LOGO! Power			
LOGO!Power power supplies with NEC Class 2:			
Types (rated output voltage / current)	24 V/0.6 A; 12 V/0.9 A	24 V/1.3 A; 15 V/1.9 A; 12 V/1.9 A; 5 V/3 A	24 V/2.5 A; 15 V/4 A; 5 V/6.3 A
Input voltage rating, range	100 – 240 V AC, 85 ... 264 V AC / 110 ... 300 V DC		
Efficiency approx. (24 V version)	81 %	86 %	90 %
Power loss in no-load operation	< 0.3 W	< 0.3 W	< 0.3 W
Ambient temperature	- 25 ... +70 °C		
Dimensions (W x H x D) in mm	18 x 90 x 53	36 x 90 x 53	54 x 90 x 53
Additional certifications	CE, CB Scheme, cULus, cURus, ATEX, IECEx, Class 1 Div 2, FM, DNV GL, ABS, SEMI F47, BV, LRS, EAC		
Additional information	siemens.com/logo-power		

SITOP PSU100C				
SITOP compact power supplies with NEC Class 2:				
Types (rated output voltage / current)	24 V/0.6 A	24 V/1.3 A	24 V/2.5 A	24 V/3.7 A
Input voltage rating, range	AC 100 – 230 V, AC 85 ... 264 V/ DC 110 ... 300 V			
Efficiency approx. (24 V version)	82 %	86 %	87 %	87 %
Power loss in no-load operation	< 0.75 W	< 0.75 W	< 0.75 W	< 0.75 W
Ambient temperature	- 20 ... +70 °C			
Dimensions (W x H x D) in mm	22.5 x 80 x 100	30 x 80 x 100	45 x 80 x 100	52.5 x 80 x 100
Additional certifications	CE, cULus, CB, cCSAus Class I Div 2, GL, ABS			
Additional information	siemens.com/sitop-compact			

	SITOP PSE2020U redundancy module	SITOP PSE200U selectivity module	Expansion module CNX8600
SITOP-Add-on-Module with NEC Class 2:			
Types (rated output voltage / current)	24 V/3.5 A	24 V/4 x 0.5 ... 3 A	24 V/8 x 0.5 ... 2.5 A
Input voltage rating, range	DC 24 V, DC 19 ... 29 V	DC 24 V, DC 22...30 V	DC 4 ... 28 V
Ambient temperature	- 20 ... +70 °C	0 ... +60 °C	-25 ... +60 °C
Dimensions (W x H x D) in mm	30 x 80 x 100	72 x 80 x 72	100 x 125 x 150
Additional certifications	CE, cULus	CE, UL, cURus, CB, cCSAus Class I Div 2, ATEX, IECEx	CE, UL, cULus, CB, cCSAus ATEX, IECEx, ABS
Additional information	siemens.com/sitop-addons	siemens.com/sitop-select	siemens.com/sitop-psu8600

Abbreviations

AHJ	Authority Having Jurisdiction
NEC	National Electrical Code
UL	Underwriters Laboratories
LVLEC	Voltage Limited Energy Circuit
CB	Circuit Breaker
SCCR	Short Circuit Current Rating

Further information

Siemens keeps you up-to-date!

You will find constantly updated news on North American standards at [siemens.com/controlpanel/northamerican-standards](https://www.siemens.com/controlpanel/northamerican-standards).

Whether you are looking for webinars, white papers, reference works, helpful engineering tools or useful information on electrical engineering, you will find comprehensive information on our website [siemens.com/controlpanel](https://www.siemens.com/controlpanel).

Integrated Control Panels – The easy way to optimized control panels

Published by:

Siemens AG
Smart Infrastructure
Electrical Products

Werner-von-Siemens-Str. 48-50
92224 Amberg, Germany

For the U.S. published by:

Siemens Industry Inc.

3617 Parkway Lane
Peachtree Corners, GA 30092
United States

Order number: SIEP-T10450-00-7600

© Siemens 2018

Subject to changes and errors.

The information in this document contains only general descriptions and/or performance features which may not always specifically reflect those described, or which may undergo modification in the course of further development of the products. The requested performance features are binding only when they are expressly agreed upon in the concluded contract.

If you would like to have more information, please contact us:

[siemens.com/controlpanel/contact](https://www.siemens.com/controlpanel/contact)